



SOURIAU

VGE1/FER1 Series

Railway Connectors



Contents

Overview

SOURIAU's railway connector range overview	06
SOURIAU's railway strategy	07
General technical characteristics	08
Description	10
Layouts overview	11
Heating curves	12
Data transmission performances	15
Ordering information	16

Mechanics

VGE1 receptacle	20
VGE1 plug	22
VGE1 specific receptacle	24
VGE1 specific plug	28
FER1 receptacle & plug	30

Contacts

Machined crimp contact	34
Quadrax cell.....	35

Backshells

Backshell overview	38
Overview - Mating possibilities	39
VGE1 CS & CE.....	40
VGE1 SS & SE	42
VGE1 JS & JE	44
VGE1 KS & KE	46

Backshells (suite)

VGE1 TS & TE	48
VGE1 VS & VE	50
VGE1 RS	52
VGE1 PS	54
Specific PS	56
VGE1 PE	57

Accessories

Grommet	60
Metallic Caps	61
Panel gasket for VGE1 & FER1	62
Fixing plate for VGE1 & FER1	63

Technical information

Contact crimping instruction	66
Contact crimp tooling / Contact removal	67
Contact mounting	68
Cabling with backshell	69
Backshell mounting sequence and coupling torque	70
Modular gasket for backshell JS, JE, KS & KE	70
How to harness a shielded cable	71
Quadrax crimping instruction	74
Backshells exploded views	75
Connector mated length / Insert orientations	76
Panel cut out	77
Purchase order memo	79
Notes.....	81

VEGET/FEER1

Overview

■ SOURIAU's railway connector range overview	06
■ SOURIAU's railway strategy	07
■ General technical characteristics	08
■ Description	10
■ Layouts overview	11
■ Heating curves	12
■ Data transmission performances	15
■ Ordering information	16



SOURIAU's railway connector range overview

For outdoor equipments

VGE1 / FER1



Up to 60 contacts
Signal, Quadrax and Fiber Optics layouts
Tested following EN 50 467 and NF F 61-030

838



Up to 61 contacts
Signal, Quadrax and Fiber Optics layouts
Compliant to NF F 61-030 and tested following EN 50 467

For indoor equipments

SMS Flame retardant



Up to 36 contacts #16
Up to 220V
Tested following EN 50 467 and NF F 61-030

SMS IP



Tested following EN 50 467 and NF F 61-030
Compliant up to 500V

UTS



Up to 23 contacts #16
Up to 120V



SOURIAU on the railway market

SOURIAU is a recognised worldwide market leader in the design and manufacture of connectors and interconnect systems for severe environments. SOURIAU has developed a dedicated range of ruggedised and reliable connectors for the railway market, fully compliant with railway standards, RoHS, as well as fire and smoke requirements.

For more than 50 years, SOURIAU has become a trusted name by major railway equipment manufacturers, their subcontractors, also signalling and infrastructure companies.

SOURIAU connectors are designed to integrate new functions such as Ethernet network, weight reduction, mixed signal-power in compliance with environmental protection. This offer is the best compromise between technology, safety, reliability and cost.

SOURIAU has been awarded IRIS certification since 2009.



- ✓ Standard contacts for 8 railway ranges
- + Same crimping tools
- + Simplified process
- = Best compromise between technology and cost



- ✓ Fiber optic
- + Quadrax technology
- = High speed solutions for real-time information



- ✓ Eco-conception & process
- + Safety international standards
- + Lightweight material
- = Safe railway equipments



General technical

Mechanical

- Design:
Derivate from MIL-DTL-5015 & VG 95234
- Durability:
500 mating/unmating cycles
An audible "click" and a yellow point indicating end of coupling (VGE1 series only)
- Shock and vibration resistance:
According to EN 61 373 - Cat.2
- Drop:
Free fall of plug at a height of 0.75m: no mechanical damage
Following NF F 61-030

Environmental

- ROHS compliant
- Operating temperature:
From -40°C to +100°C
- Dry heat test:
100 ° for 96 hours
- Salt spray resistance:
500 hours
- Damp heat:
21 days, 40°C, 95% relative humidity
- Sealing level:
IP67, 1m deep for 30 minutes max, coupled with appropriate backshell and grommet or accessories
- Dynamic sealing:
IP67 guaranteed when cable is moving
- Fire and smoke:
Insert material: HL3/R22 and HL3/R23 following EN 45 545,
NFPA 130 compliant
- Resistance to fluids:
Gas oil, mineral oil, acid bath, basic bath, following NF F 61-030,
oxalic acid





characteristics



Material

- Shell:
Aluminum alloy
Conductive plating - 500 hours salt spray resistant
- Insert:
Hard thermoplastic: HL3/R22 and HL3/R23 following EN 45 545, NFPA 130 compliant
- Contacts:
Machined crimp contacts / PCB contacts

Electrical

- Contacts resistance, following NF F 61-030:
Contact #20: 6 m Ω max, Contact #16: 2.5 m Ω max,
Contact #12: 1.3 m Ω max, Contact #8: 0.9 m Ω max
Quadrax Contacts #20: ≤ 6 m Ω , ≤ 2 m Ω (cell)
- Contact rating:
Contact #20: 7A, Contact #16: 15A, Contact #12: 20A,
Contact #8: 30A
- Dielectric resistance:
Contact #20: 1500 Veff, Contact #16: 2550 Veff,
Contact #12: 3250 Veff, Contact #8: 3250 Veff
Quadrax between contacts #20: ≥ 1000 V
Quadrax between cell / contacts #20 : ≥ 500 V
- Insulation resistance:
 $\geq 3\ 000$ M Ω (under 100 Vdc)
 $\geq 5\ 000$ M Ω (under 500 Vdc)
 $\geq 4\ 000$ M Ω (under 220 Vdc)
Quadrax: ≥ 3000 M Ω (contacts #20)
- Creepage and clearance:
6 mm creepage, 2 mm clearance for layout 14A6
2.1mm creepage, 0.8mm clearance for layout 14A10
9 mm mini for layouts 18-19, 22-14, 28-21, 40A60
12 mm mini for layouts using #12 and #8 contacts
- Operating voltage:
110 V following NF F 61-030 for layout 14A6
110V following EN 50-124 for layout 14A10
220 V following NF F 61-030 for layouts 18-19, 22-14,
28-21, 40A60
500 Vcc following NF F 61-030 for layouts #12 and #8
- Shell continuity:
20 m Ω max
- High Speed data Transmission performances, IEC11-801:
Standard contact: cat. 5, Quadrax contact: cat. 6



Description

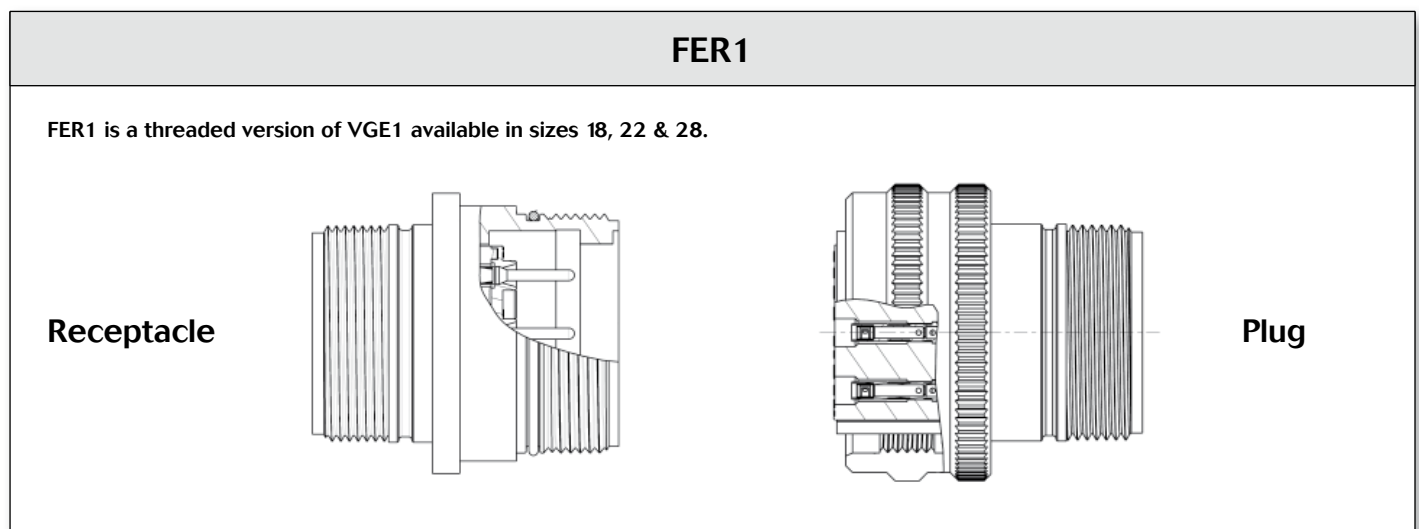
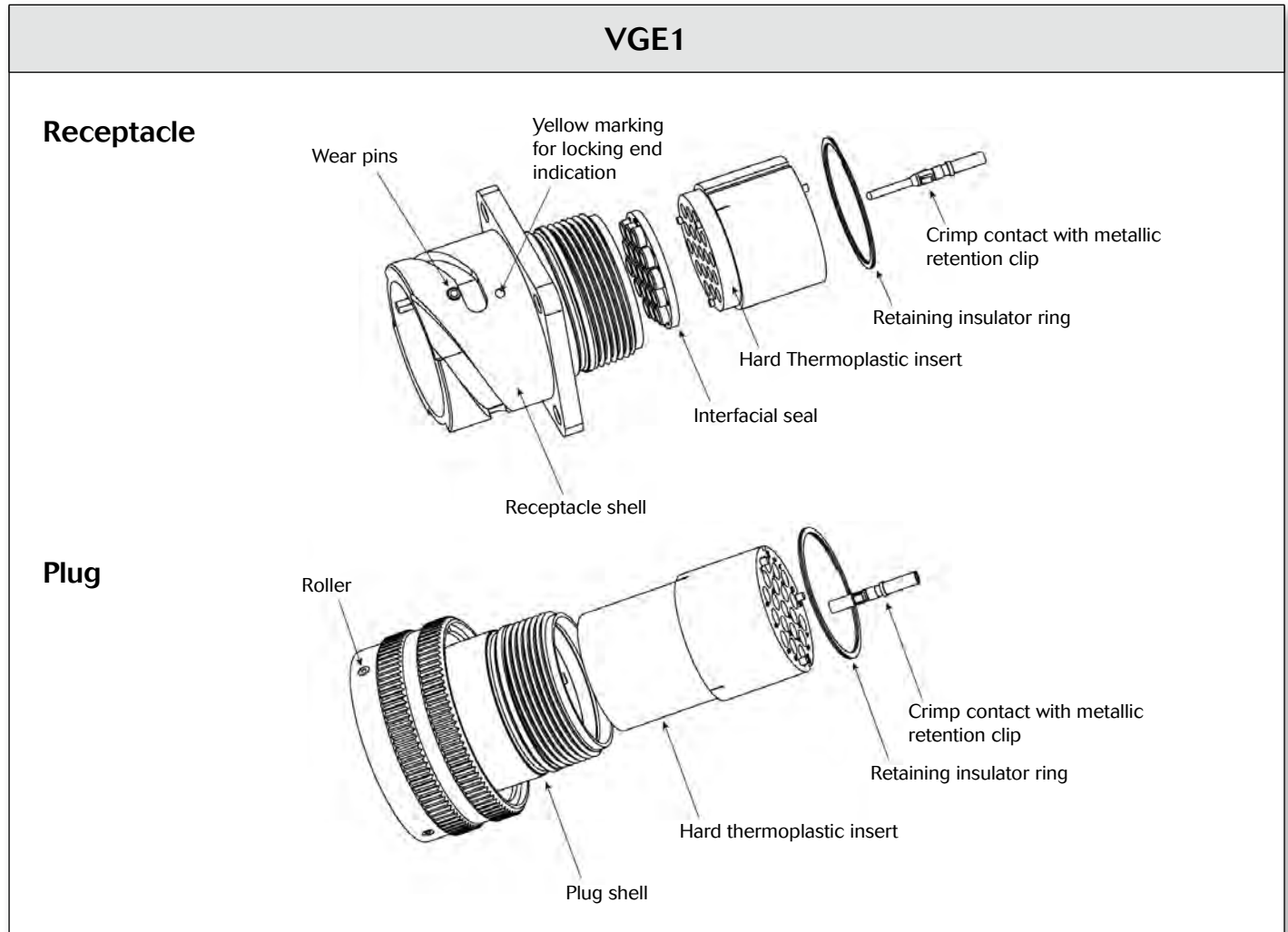



Layouts overview

<p>Size 14</p> <div style="display: flex; justify-content: space-around;"> <div style="text-align: center;"> <p>14A6</p> <p>6 Contacts Ø1.6 mm (#16) 110 V following NF F 61-030 for layout 14A6 110 V following EN50-124 for layout 14A10</p> </div> <div style="text-align: center;"> <p>14A10</p> <p>10 Contacts Ø1 mm (#20) 110 V following EN50-124 for layout 14A10</p> </div> <div style="text-align: center;"> <p>Quadrax 14R</p> <p>4 Contacts Ø1 mm (#20)</p> </div> </div>	<p>Size 18</p> <div style="display: flex; justify-content: space-around;"> <div style="text-align: center;"> <p>18-19</p> <p>10 Contacts Ø1.6 mm (#16) 220 V following NF F 61-030 for layout 18-19</p> </div> <div style="text-align: center;"> <p>Quadrax 18A1</p> <p>4 Contacts Ø1 mm (#20)</p> </div> </div>		
<p>Size 20</p> <div style="text-align: center;"> <p>20-15</p> <p>7 Contacts Ø2.4 mm (#12) Max. operating voltage: 500 Vcc following NF F 61-030</p> </div>	<p>Size 22</p> <div style="text-align: center;"> <p>22-14</p> <p>19 Contacts Ø1.6 mm (#16) Max. operating voltage: 220 V following NF F 61-030</p> </div>	<p>Size 24</p> <div style="text-align: center;"> <p>24-10</p> <p>7 Contacts Ø3.6 mm (#8) Max. operating voltage: 500 Vcc following NF F 61-030</p> </div>	
<p>Size 28</p> <div style="text-align: center;"> <p>28-21</p> <p>37 Contacts Ø1.6 mm (#16) Max. operating voltage: 220 V following NF F 61-030</p> </div>	<p>Size 32</p> <div style="text-align: center;"> <p>32A13</p> <p>13 Contacts Ø2.4 mm (#12) Max. operating voltage: 220 V following NF F 61-030</p> </div>	<p>Size 36</p> <div style="text-align: center;"> <p>36A22</p> <p>22 Contacts Ø2.4 mm (#12) Max. operating voltage: 500 Vcc following NF F 61-030</p> </div>	
<p>Size 40</p> <div style="display: flex; justify-content: space-around;"> <div style="text-align: center;"> <p>40A35</p> <p>35 Contacts Ø2.4 mm (#12) Max. operating voltage: 500 Vcc following NF F 61-030</p> </div> <div style="text-align: center;"> <p>40A60</p> <p>60 Contacts Ø1.6 mm (#16) Max. operating voltage: 220 V following NF F 61-030</p> </div> </div>			

n = VGE1 standard version

s = FER1 standard version



Heating curves

Test conditions:

- Current per contact
- All contacts loaded
- Max heating in C° allowed following NF F 61-030: 50°C

Size 18

18-19

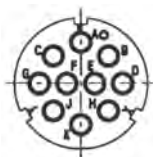

10 Contacts
Ø1.6 mm (#16)

18-19 only Max. operating voltage: 220 V following NF F 61-030

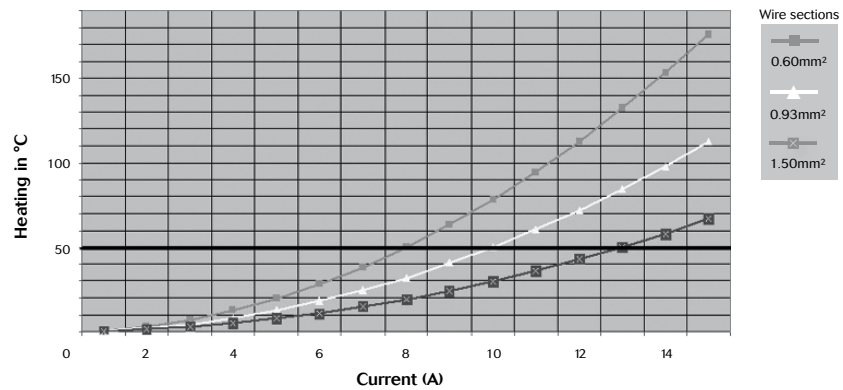

Size 20

20-15

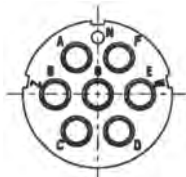

7 Contacts
Ø2.4 mm (#12)

Max. operating voltage: 500 Vcc following NF F 61-030

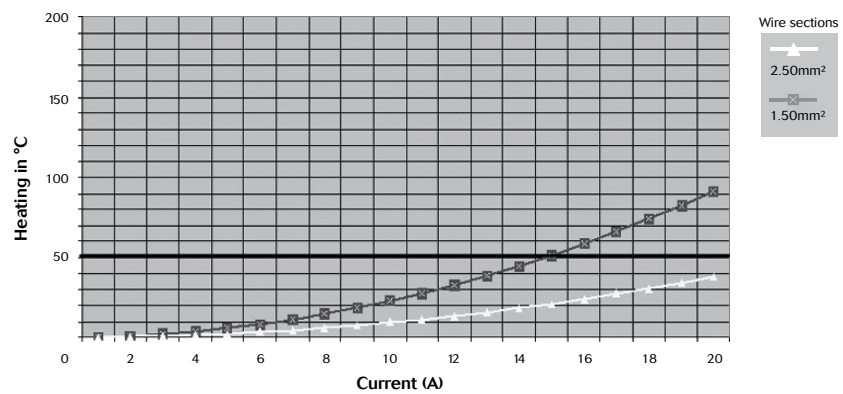

Size 22

22-14

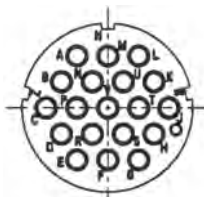

19 Contacts
Ø1.6 mm (#16)

Max. operating voltage: 220 V following NF F 61-030

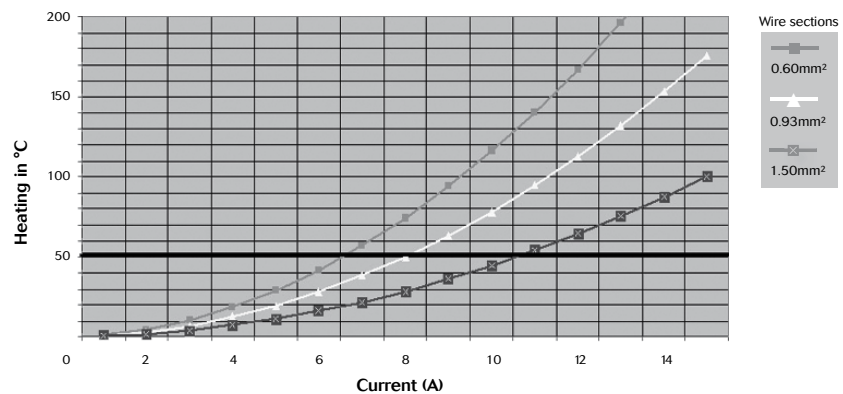

VGE1/FER1 Series



Size 24

24-10

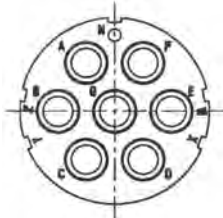

7 Contacts
Ø3.6 mm (#8)

Max. operating voltage: 500 Vcc
following NF F 61-030

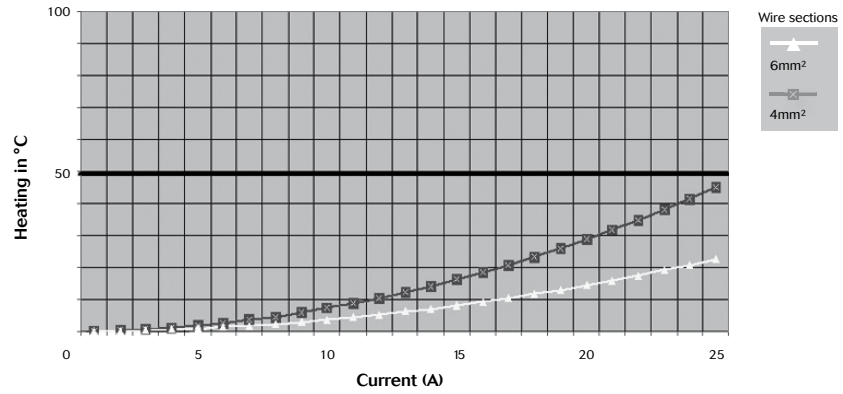

Size 28

28-21

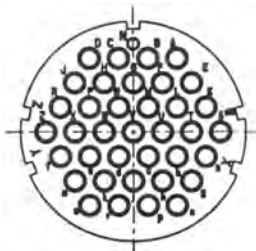

37 Contacts
Ø1.6 mm (#16)

Max. operating voltage: 220 V
following NF F 61-030

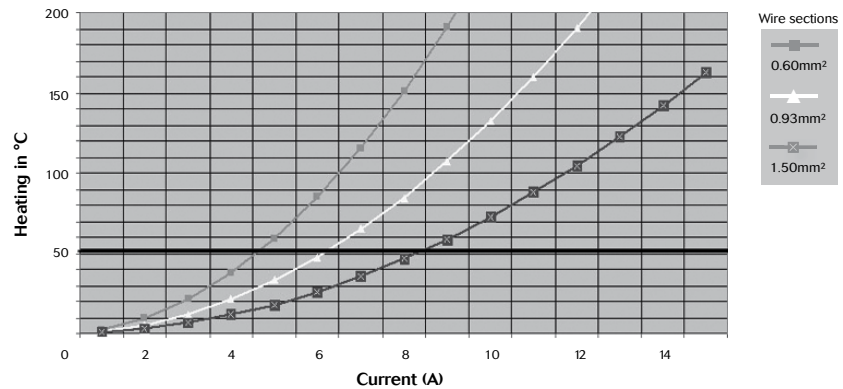

Size 32

32A13

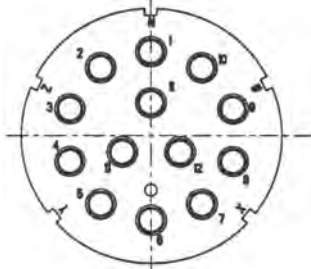

13 Contacts
Ø2.4 mm (#12)

Max. operating voltage: 220 V
following NF F 61-030

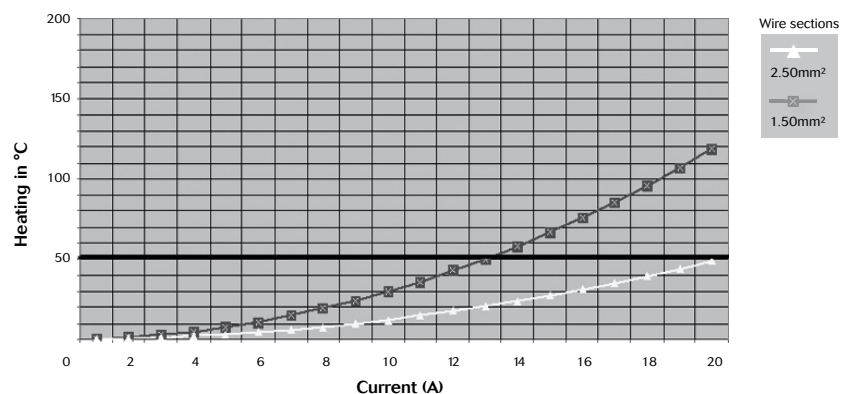

VGE1/FER1 Series



Size 36

36A22

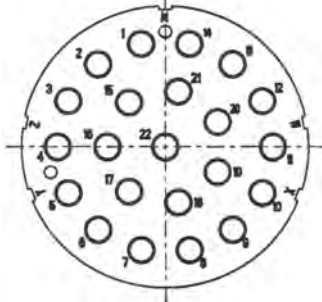

22 Contacts
Ø2.4 mm (#12)

Max. operating voltage: 500 Vcc
following NF F 61-030

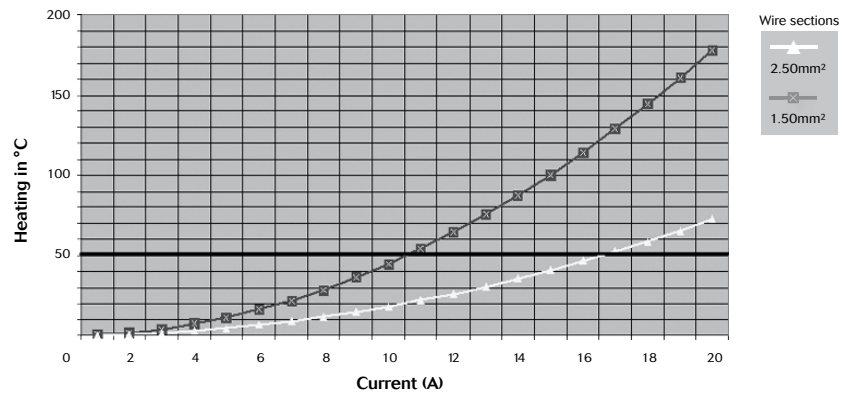

Size 40

40A35

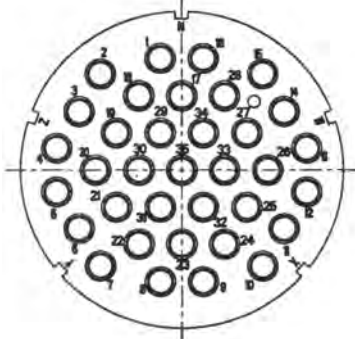

35 Contacts
Ø2.4 mm (#12)

Max. operating voltage: 500 Vcc
following NF F 61-030

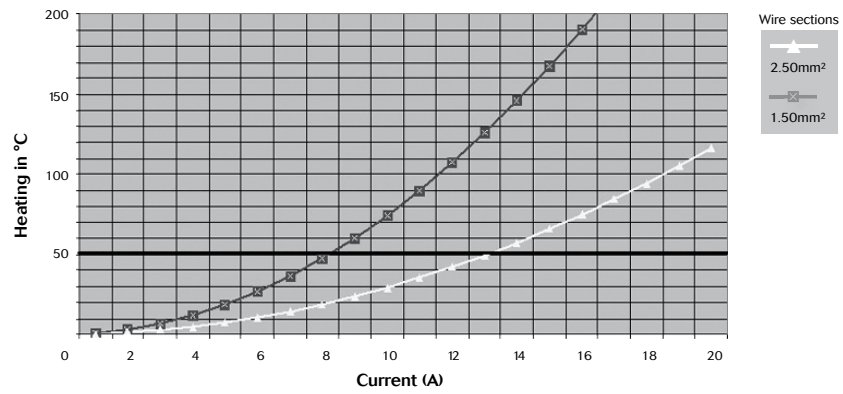

40A60

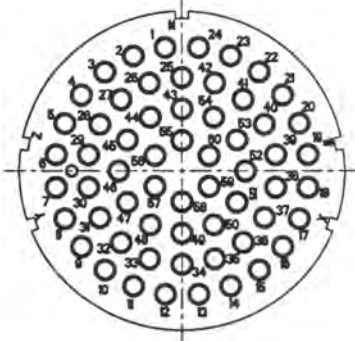

60 Contacts
Ø1.6 mm (#16)

Max. operating voltage: 220 V
following NF F 61-030

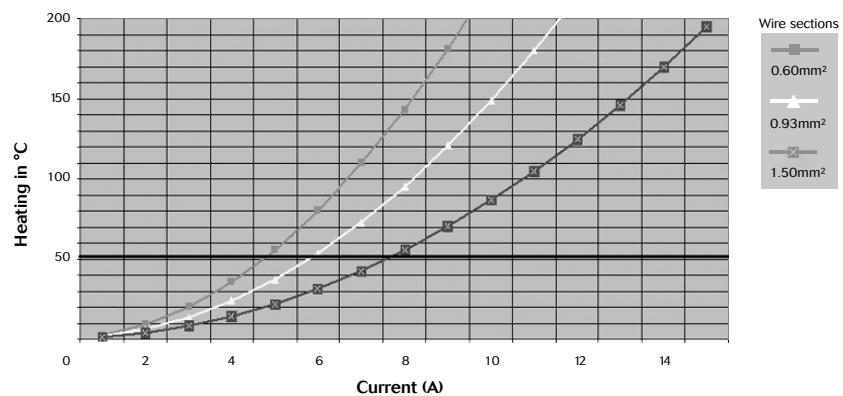



Data transmission performances

High speed data transmissions with layouts 18-19, 14R and 18A1

Tests following IEC 11-801

For cabling specifications please contact us.

18-19

Cat. 5 level obtained with 4 contacts #16

Exemple of performances with a 18-19 connector and a 2 pairs cable, for cabling specification, consult us:

Standard version with 4 contacts #16: Cat. 5 / IEC11-801

18-19

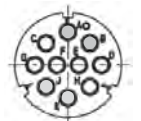

4 Contacts
Ø1.6 mm (#16)

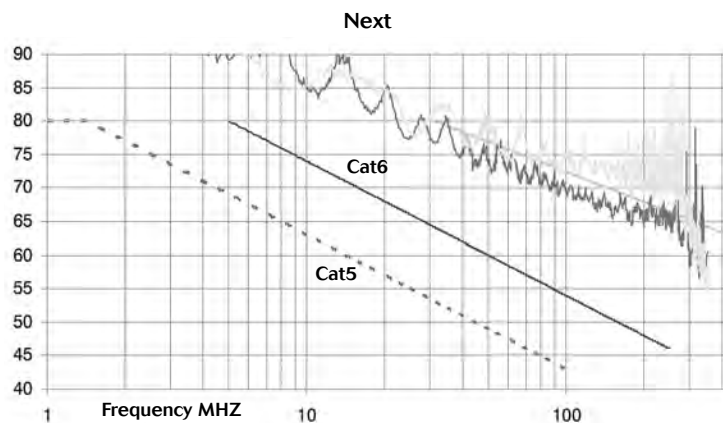
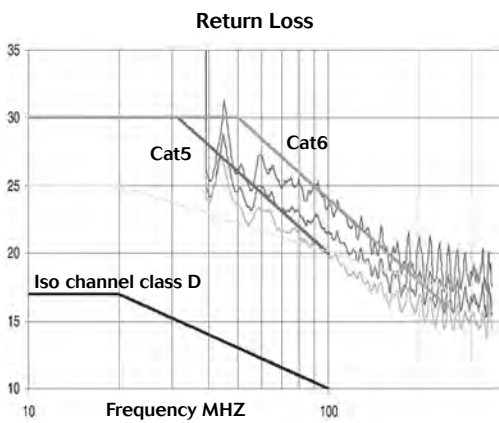

Quadrax-14R & 18A1

Cat. 6 level obtained with 1 contact Quadrax

Exemple of performances with a 18A1 connector and a quarte cable:

Quadrax version: Cat. 6 / IEC11-801

14R

18A1

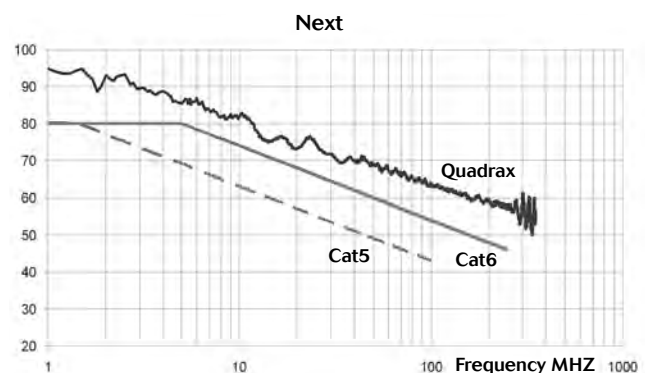
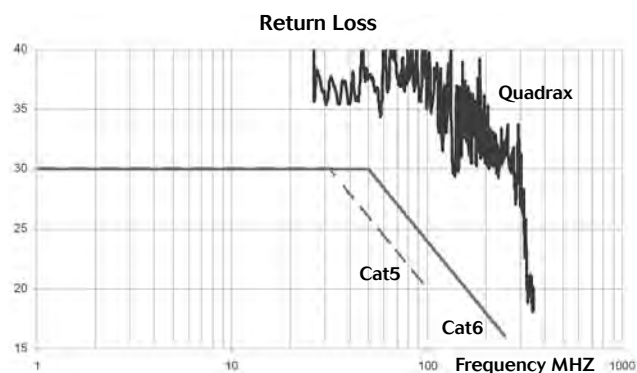



Ordering information

Receptacle, plug, backshells, contacts and accessories have to be ordered separately.

VGE1 (page 20-29)

Basic Series	VGE1	B	22	14	P	N	--
Shell type:							
B: Rear mounting receptacle							
D: Plug							
C: Rear mounting receptacle for PC tails contact # 16							
H: Jam Nut Receptacle with shielding ring - only available for sizes 18 and 22							
Shell size:							
14; 18; 20; 22; 24; 28; 32; 36; 40							
Layouts: see page 11							
Contact type:							
P: Pin							
S: Socket							
Insert Orientation: see page 76							
N; W; X; Y; Z or Ø							
(Ø = insert not installed in the shell)							
Specification Code:							
Ø4: Receptacle delivered with non conductive panel gasket							
Ø5: Receptacle delivered with conductive panel gasket							
11: Receptacle and plug delivered with plastic cap							

Connector marking example: VGE1B2214PN

FER1 (page 30-31)

Basic Series	FER1	B	22	14	P	N	--
Shell type:							
B: Rear mounting receptacle							
D: Plug							
Shell size:							
18; 22; 28 (Other sizes: please consult us)							
Layouts: see page 11							
Contact type:							
P: Pin							
S: Socket							
Insert Orientation: see page 76							
N; W; X; Y; Z or Ø							
(Ø = insert not installed in the shell)							
Specification Code:							
Ø4: Receptacle delivered with non conductive panel gasket							
Ø5: Receptacle delivered with conductive panel gasket							
11: Receptacle and plug delivered with plastic cap							

Connector marking example: FER1D2821SN



VGE1 specific receptacle - Dimensions

Receptacle with PC tails contacts

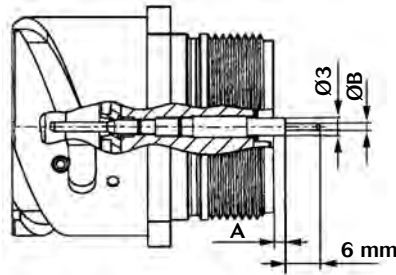

Part numbers ⁽²⁾	Shell size	A max	ØB max*		
VGE1 C 1819 PN...	18	2.00	Gold plating standard (-) Ø 1.2	Gold plating specific (01) Ø 1	Tin plating (14) Ø 1
VGE1 C 2214 PN...	22				
VGE1 C 2821 PN...	28	- 0.40			

*: example of Part numbers with Gold plating standard VGE1C1819PN, with Gold plating specific VGE1C1819PN01, with Tin plating VGE1C1819PN14

Jam nut receptacle with shielding ring

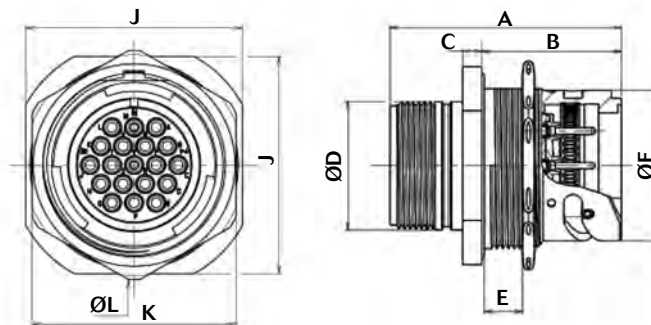

Part numbers ⁽²⁾	Shell size	A max	B	C	ØD max	E max	ØF	J	K	ØL	Weight ⁽³⁾
VGE1 H 1819 ...N	18	57.70	34.50	4.80	25.50	10.00	30.80	42.00	39.90	44.50	70 g
VGE1 H 2214 ...N	22	57.70	34.50	4.80	31.90	10.00	37.40	49.00	46.00	51.30	105 g

2: example of Part numbers with orientation "N", "N" can be replaced by other orientation - see column orientation
3: weight for indication - receptacle + insert without contact

Note: max dimensions in mm
Dimensions are not contractual and may be subject to modifications



Connector mated length

VGE1 plug & receptacle

Shell size	A max	B max
14	70	7
18	75.50	7.80
20		
22		
24		
28	80.50	8.80
32		
36		
40		

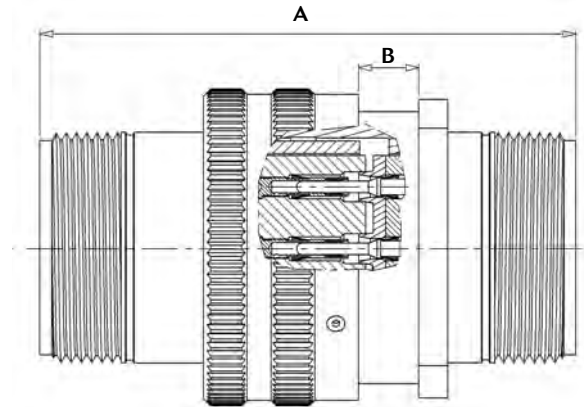

Note: max dimensions in mm
Dimensions are not contractual and may be subject to modifications

Insert orientations

Alternative insert orientation positions

Layouts	N	W	X	y	Z
14A6 / 14A10 14R	0°	-	-	108°	-
18-19	0°	-	120°	240°	-
20-15	0°	80°	-	-	280°
22-14	0°	80°	-	-	280°
24-10	0°	80°	110°	250°	280°
28-21	0°	80°	110°	250°	280°
32A13	0°	65°	130°	230°	295°
36A22	0°	80°	110°	250°	280°
40A35	0°	70°	130°	230°	290°
40A60	0°	80°	110°	250°	280°

22-14 position N

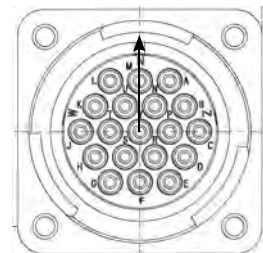

22-14 position W

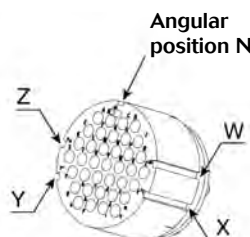
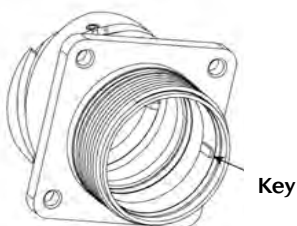
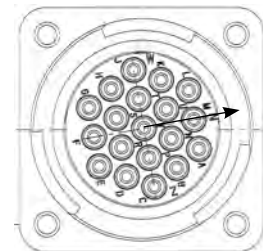

0°: insert not mounted in the shell