

VTS-1 Process Photodiodes

VTS__11, __12

E G & G VACTEC

PRODUCT DESCRIPTION

Large area planar silicon photodiodes primarily intended for use in the photovoltaic mode. These devices have low series resistance, moderate shunt resistance and high open circuit voltage at nominal light levels for use in power conversion and battery charging applications. Cells have solderable contacts and are available with or without flexible flying leads. Devices with leads are acrylic (plastic) coated.

PACKAGE DIMENSIONS inch (mm)

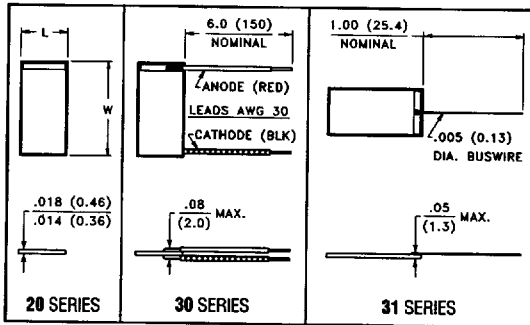

ABSOLUTE MAXIMUM RATINGS

- Storage Temperature:
 -40°C to 150°C Series 20, 31
 -40°C to 105°C Series 30
- Operating Temperature:
 -40°C to 125°C Series 20, 31
 -40°C to 105°C Series 30

CASE 44B
 ANODE (ACTIVE) SURFACE SHOWN
 CATHODE IS BACKSIDE

DIMENSIONS	VTS__11	VTS__12
L	.087 (2.21)	.100 (2.54)
W	.200 (5.08)	.200 (5.08)
ACTIVE AREA	.0132 (8.5 ²)	.0162 (10 ²)

ELECTRO-OPTICAL CHARACTERISTICS @ 25°C (See also VTS-1 curves, page 75)

SYMBOL	CHARACTERISTIC	TEST CONDITIONS	VTS__11			VTS__12						UNITS
			Min.	Typ.	Max.	Min.	Typ.	Max.	Min.	Typ.	Max.	
I _{sc}	Short Circuit Current	H = 100 fc, 2850 K	41	55		50	70					μA
TC I _{sc}	I _{sc} Temp. Coefficient	2850 K		.20			.20					% / °C
I _{sc}	Short Circuit Current	H = 100 mW/cm ²		1.8			2.1					mA
V _{oc}	Open Circuit Voltage	H = 100 fc, 2850 K		.45			.45					V
V _{oc}	Open Circuit Voltage	H = 100 mW/cm ²		.57			.57					V
TC V _{oc}	V _{oc} Temp. Coefficient	2850 K		-2.0			-2.0					% / °C
I _d	Dark Current	H = 0, V _R = 500 mV		0.1	1		0.2	2				μA
R _{SH}	Shunt Resistance	H = 0, V = 10 mV		2.2			1.1					MΩ
TC R _{SH}	R _{SH} Temp. Coefficient	H = 0, V = 10 mV		-8.0			-8.0					% / °C
C _J	Junction Capacitance	H = 0, V = 0 V		2.3			2.7					nF
λ _{range}	Spectral Application Range		400		1050	400		1050				nm
λ _p	Spectral Response - Peak			875			875					nm
S _R	Sensitivity	@ Peak		.51			.51					A/W