

128-common x 132-segment BIT MAP LCD DRIVER

■ GENERAL DESCRIPTION

The **NJU6679** is a 128-common x 132-segment bit map LCD driver to display graphics or characters.

It contains 25,344 bits display data RAM, microprocessor interface circuits, instruction decoder, and common and segment drivers.

An image data from CPU through the serial or 8-bit parallel interface are stored into the 25,344 bits internal display data RAM and are displayed on the LCD panel through the commons and segments drivers.

The **NJU6679** displays 128 x 132 dots graphics or 8-character 8-line by 16 x 16 dots character.

The **NJU6679** contains a built-in OSC circuit for reducing external components. And it features Partial Display Function containing selectable active display block(s) (two blocks max.) and optimizing the duty cycle ratio. This function dramatically reduces the operating current, setting the optimum boosted voltage combined with a programmable voltage booster circuit and an electrical variable resistor. As result, it reduces the operating current.

The operating voltage from 2.4V to 3.6V and low operating current are suitable for small size battery operation items.

■ PACKAGE OUTLINE

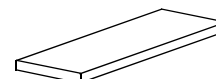

NJU6679CJ

■ FEATURES

- Direct Correspondence of Display Data RAM to LCD Pixel
- Display Data RAM - 25,344 bits ;(1.5 times over than display size)
- LCD drivers - 128-common and 132-segment
- Direct connection to 8-bit Microprocessor interface for both of 68 and 80 type MPU
- Serial Interface
- Partial Display Function Two limited active display blocks setting. Duty ratio set automatically.
- Easy Vertical Scroll by setting the start line address of over size display data RAM
- Programmable Bias selection ; 1/4, 1/5, 1/6, 1/7, 1/8, 1/9, 1/10, 1/11, 1/12 bias
- Common Driver Order Assignment by mask option

Version	C0 to C127(Pin name)
NJU6679A	Com0 to Com127
NJU6679B	Com127 to Com0

- Useful Instruction Sets
Display ON/OFF Cont, Display Start Line Set, Page Address Set, Column Address Set, Status Read, Display Data Read/Write, Inverse Display, All On/Off, Partial Display, Bias Select, n-Line Inverse, Voltage Booster Circuits Multiple Select(Maximum 6-time), Read Modify Write, Power Saving, ADC Select, etc.
- Power Supply Circuits for LCD; Programmable Voltage Booster Circuits(6-time Maximum, Voltage boosting polarity:Negative voltage(VDD Common)),Regulator, Voltage Follower (x 4)
- Precision Electrical Variable Resistance
- Low Power Consumption
- Operating Voltage --- 2.4V to 3.6V
- LCD Driving Voltage --- 6.0V to 18V
- Package Outline --- COF / TCP / Bumped Chip
- C-MOS Technology (Substrate:N)

■ PAD LOCATION

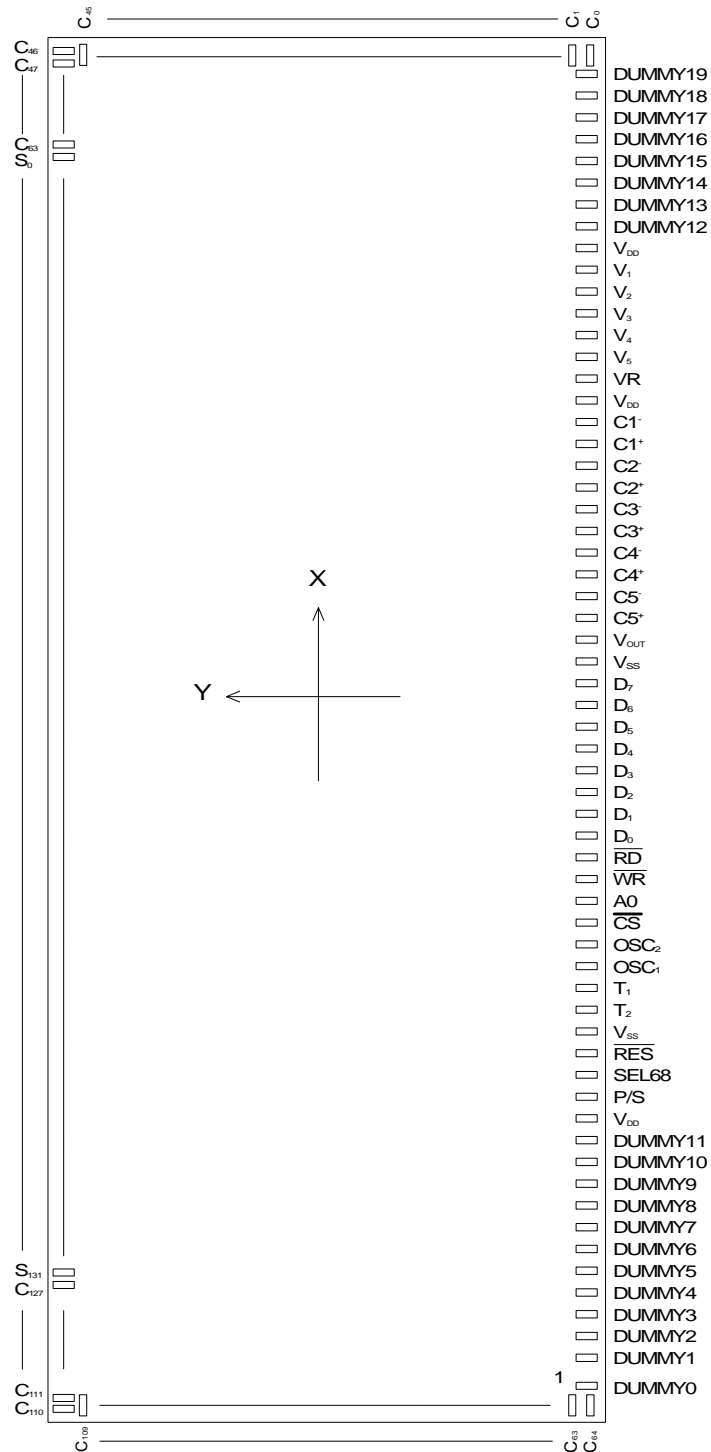

Chip Center	: X=0um, Y=0um
Chip Size	: X=10.31mm, Y=3.13mm
Chip Thickness	: 675um ± 30um
Bump Size	: 45um x 83um
Pad pitch	: 60um (Min)
Bump Height	: 15um TYP.
Bump Material	: Au
Voltage boosting polarity	: Negative voltage (VDD Common)
Substrate	: N

■ TERMINAL DESCRIPTION

Chip Size 10.31 x 3.13mm (Chip Center X=0um, Y=0um)

PAD No.	Terminal	X= um	Y= um
1	DUMMY0	-4884	-1405
2	DUMMY1	-4132	-1405
3	DUMMY2	-4062	-1405
4	DUMMY3	-3992	-1405
5	DUMMY4	-3922	-1405
6	DUMMY5	-3852	-1405
7	DUMMY6	-3782	-1405
8	DUMMY7	-3712	-1405
9	DUMMY8	-3642	-1405
10	DUMMY9	-3572	-1405
11	DUMMY10	-3502	-1405
12	DUMMY11	-3432	-1405
13	V _{DD}	-3270	-1405
14	P/S	-3104	-1405
15	SEL68	-2884	-1405
16	RES	-2648	-1405
17	V _{SS}	-2490	-1405
18	T ₂	-2333	-1405
19	T ₁	-2098	-1405
20	OSC ₁	-1877	-1405
21	OSC ₂	-1641	-1405
22	CS	-1420	-1405
23	A0	-1184	-1405
24	WR	-954	-1405
25	RD	-717	-1405
26	D ₀	-481	-1405
27	D ₁	-260	-1405
28	D ₂	-40	-1405
29	D ₃	180	-1405
30	D ₄	400	-1405
31	D ₅	621	-1405
32	D ₆ (SCL)	841	-1405
33	D ₇ (SI)	1061	-1405
34	V _{SS}	1222	-1405
35	V _{OUT}	1398	-1405
36	C5 ⁺	1468	-1405
37	C5 ⁻	1538	-1405
38	C4 ⁺	1608	-1405
39	C4 ⁻	1678	-1405
40	C3 ⁺	1748	-1405
41	C3 ⁻	1818	-1405
42	C2 ⁺	1888	-1405
43	C2 ⁻	1958	-1405
44	C1 ⁺	2028	-1405
45	C1 ⁻	2098	-1405
46	V _{DD}	2168	-1405
47	VR	2327	-1405
48	V ₅	2582	-1405
49	V ₄	2652	-1405
50	V ₃	2722	-1405

PAD No.	Terminal	X= um	Y= um
51	V ₂	2792	-1405
52	V ₁	2862	-1405
53	V _{DD}	2932	-1405
54	DUMMY12	3315	-1405
55	DUMMY13	3385	-1405
56	DUMMY14	3455	-1405
57	DUMMY15	3525	-1405
58	DUMMY16	3595	-1405
59	DUMMY17	3665	-1405
60	DUMMY18	3735	-1405
61	DUMMY19	4884	-1405
62	C ₀	4995	-1416
63	C ₁	4995	-1356
64	C ₂	4995	-1296
65	C ₃	4995	-1236
66	C ₄	4995	-1176
67	C ₅	4995	-1116
68	C ₆	4995	-1056
69	C ₇	4995	-996
70	C ₈	4995	-936
71	C ₉	4995	-876
72	C ₁₀	4995	-816
73	C ₁₁	4995	-756
74	C ₁₂	4995	-696
75	C ₁₃	4995	-636
76	C ₁₄	4995	-576
77	C ₁₅	4995	-516
78	C ₁₆	4995	-456
79	C ₁₇	4995	-396
80	C ₁₈	4995	-336
81	C ₁₉	4995	-276
82	C ₂₀	4995	-216
83	C ₂₁	4995	-156
84	C ₂₂	4995	-96
85	C ₂₃	4995	-36
86	C ₂₄	4995	24
87	C ₂₅	4995	84
88	C ₂₆	4995	144
89	C ₂₇	4995	204
90	C ₂₈	4995	264
91	C ₂₉	4995	324
92	C ₃₀	4995	384
93	C ₃₁	4995	444
94	C ₃₂	4995	504
95	C ₃₃	4995	564
96	C ₃₄	4995	624
97	C ₃₅	4995	684
98	C ₃₆	4995	744
99	C ₃₇	4995	804
100	C ₃₈	4995	864

PAD No.	Terminal	X= um	Y= um
101	C ₃₉	4995	924
102	C ₄₀	4995	984
103	C ₄₁	4995	1044
104	C ₄₂	4995	1104
105	C ₄₃	4995	1164
106	C ₄₄	4995	1224
107	C ₄₅	4995	1284
108	C ₄₆	5010	1405
109	C ₄₇	4950	1405
110	C ₄₈	4890	1405
111	C ₄₉	4830	1405
112	C ₅₀	4770	1405
113	C ₅₁	4710	1405
114	C ₅₂	4650	1405
115	C ₅₃	4590	1405
116	C ₅₄	4530	1405
117	C ₅₅	4470	1405
118	C ₅₆	4410	1405
119	C ₅₇	4350	1405
120	C ₅₈	4290	1405
121	C ₅₉	4230	1405
122	C ₆₀	4170	1405
123	C ₆₁	4110	1405
124	C ₆₂	4050	1405
125	C ₆₃	3990	1405
126	S ₀	3930	1405
127	S ₁	3870	1405
128	S ₂	3810	1405
129	S ₃	3750	1405
130	S ₄	3690	1405
131	S ₅	3630	1405
132	S ₆	3570	1405
133	S ₇	3510	1405
134	S ₈	3450	1405
135	S ₉	3390	1405
136	S ₁₀	3330	1405
137	S ₁₁	3270	1405
138	S ₁₂	3210	1405
139	S ₁₃	3150	1405
140	S ₁₄	3090	1405
141	S ₁₅	3030	1405
142	S ₁₆	2970	1405
143	S ₁₇	2910	1405
144	S ₁₈	2850	1405
145	S ₁₉	2790	1405
146	S ₂₀	2730	1405
147	S ₂₁	2670	1405
148	S ₂₂	2610	1405
149	S ₂₃	2550	1405
150	S ₂₄	2490	1405

PAD No.	Terminal	X= um	Y= um
151	S ₂₅	2430	1405
152	S ₂₆	2370	1405
153	S ₂₇	2310	1405
154	S ₂₈	2250	1405
155	S ₂₉	2190	1405
156	S ₃₀	2130	1405
157	S ₃₁	2070	1405
158	S ₃₂	2010	1405
159	S ₃₃	1950	1405
160	S ₃₄	1890	1405
161	S ₃₅	1830	1405
162	S ₃₆	1770	1405
163	S ₃₇	1710	1405
164	S ₃₈	1650	1405
165	S ₃₉	1590	1405
166	S ₄₀	1530	1405
167	S ₄₁	1470	1405
168	S ₄₂	1410	1405
169	S ₄₃	1350	1405
170	S ₄₄	1290	1405
171	S ₄₅	1230	1405
172	S ₄₆	1170	1405
173	S ₄₇	1110	1405
174	S ₄₈	1050	1405
175	S ₄₉	990	1405
176	S ₅₀	930	1405
177	S ₅₁	870	1405
178	S ₅₂	810	1405
179	S ₅₃	750	1405
180	S ₅₄	690	1405
181	S ₅₅	630	1405
182	S ₅₆	570	1405
183	S ₅₇	510	1405
184	S ₅₈	450	1405
185	S ₅₉	390	1405
186	S ₆₀	330	1405
187	S ₆₁	270	1405
188	S ₆₂	210	1405
189	S ₆₃	150	1405
190	S ₆₄	90	1405
191	S ₆₅	30	1405
192	S ₆₆	-30	1405
193	S ₆₇	-90	1405
194	S ₆₈	-150	1405
195	S ₆₉	-210	1405
196	S ₇₀	-270	1405
197	S ₇₁	-330	1405
198	S ₇₂	-390	1405
199	S ₇₃	-450	1405
200	S ₇₄	-510	1405

PAD No.	Terminal	X= um	Y= um
201	S75	-570	1405
202	S76	-630	1405
203	S77	-690	1405
204	S78	-750	1405
205	S79	-810	1405
206	S80	-870	1405
207	S81	-930	1405
208	S82	-990	1405
209	S83	-1050	1405
210	S84	-1110	1405
211	S85	-1170	1405
212	S86	-1230	1405
213	S87	-1290	1405
214	S88	-1350	1405
215	S89	-1410	1405
216	S90	-1470	1405
217	S91	-1530	1405
218	S92	-1590	1405
219	S93	-1650	1405
220	S94	-1710	1405
221	S95	-1770	1405
222	S96	-1830	1405
223	S97	-1890	1405
224	S98	-1950	1405
225	S99	-2010	1405
226	S100	-2070	1405
227	S101	-2130	1405
228	S102	-2190	1405
229	S103	-2250	1405
230	S104	-2310	1405
231	S105	-2370	1405
232	S106	-2430	1405
233	S107	-2490	1405
234	S108	-2550	1405
235	S109	-2610	1405
236	S110	-2670	1405
237	S111	-2730	1405
238	S112	-2790	1405
239	S113	-2850	1405
240	S114	-2910	1405
241	S115	-2970	1405
242	S116	-3030	1405
243	S117	-3090	1405
244	S118	-3150	1405
245	S119	-3210	1405
246	S120	-3270	1405
247	S121	-3330	1405
248	S122	-3390	1405
249	S123	-3450	1405
250	S124	-3510	1405

PAD No.	Terminal	X= um	Y= um
251	S125	-3570	1405
252	S126	-3630	1405
253	S127	-3690	1405
254	S128	-3750	1405
255	S129	-3810	1405
256	S130	-3870	1405
257	S131	-3930	1405
258	C127	-3990	1405
259	C126	-4050	1405
260	C125	-4110	1405
261	C124	-4170	1405
262	C123	-4230	1405
263	C122	-4290	1405
264	C121	-4350	1405
265	C120	-4410	1405
266	C119	-4470	1405
267	C118	-4530	1405
268	C117	-4590	1405
269	C116	-4650	1405
270	C115	-4710	1405
271	C114	-4770	1405
272	C113	-4830	1405
273	C112	-4890	1405
274	C111	-4950	1405
275	C110	-5010	1405
276	C109	-4995	1284
277	C108	-4995	1224
278	C107	-4995	1164
279	C106	-4995	1104
280	C105	-4995	1044
281	C104	-4995	984
282	C103	-4995	924
283	C102	-4995	864
284	C101	-4995	804
285	C100	-4995	744
286	C99	-4995	684
287	C98	-4995	624
288	C97	-4995	564
289	C96	-4995	504
290	C95	-4995	444
291	C94	-4995	384
292	C93	-4995	324
293	C92	-4995	264
294	C91	-4995	204
295	C90	-4995	144
296	C89	-4995	84
297	C88	-4995	24
298	C87	-4995	-36
299	C86	-4995	-96
300	C85	-4995	-156

PAD No.	Terminal	X= um	Y= um
301	C84	-4995	-216
302	C83	-4995	-276
303	C82	-4995	-336
304	C81	-4995	-396
305	C80	-4995	-456
306	C79	-4995	-516
307	C78	-4995	-576
308	C77	-4995	-636
309	C76	-4995	-696
310	C75	-4995	-756
311	C74	-4995	-816
312	C73	-4995	-876
313	C72	-4995	-936
314	C71	-4995	-996
315	C70	-4995	-1056
316	C69	-4995	-1116
317	C68	-4995	-1176
318	C67	-4995	-1236
319	C66	-4995	-1296
320	C65	-4995	-1356
321	C64	-4995	-1416

■ BLOCK DIAGRAM

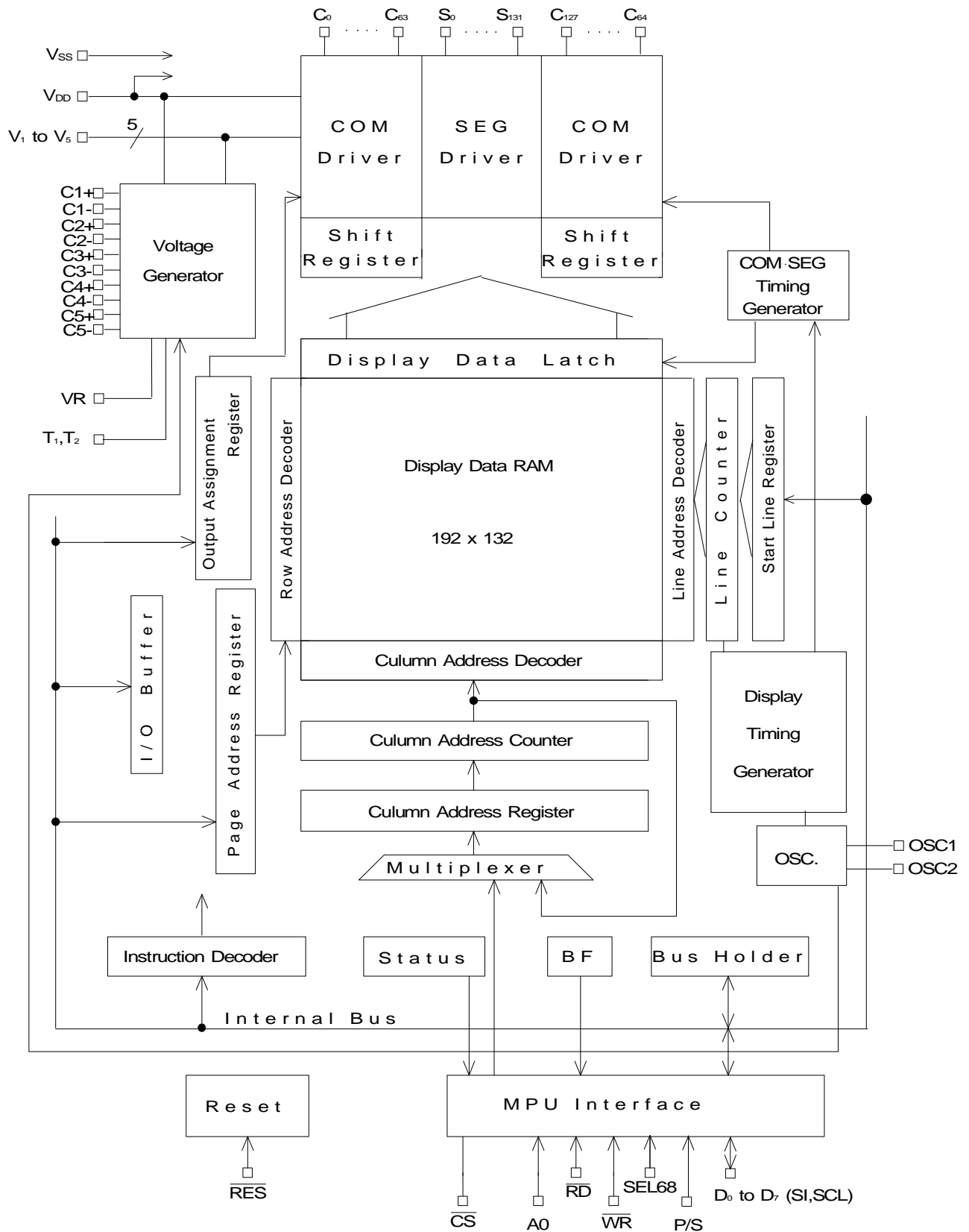

■ TERMINAL DESCRIPTION

No.	Symbol	I/O	Function																																																		
1 to 12, 54 to 61	DUMMY0 to DUMMY19		Dummy Terminals. These are open terminals electrically.																																																		
13,46,53	VDD	Power	Power Supply Terminal (+2.4V - +3.6V)																																																		
17,34	VSS	GND	Ground Terminal (0V)																																																		
52 51 50 49 48	V1 V2 V3 V4 V5	Power	<p>LCD Driving Voltage Supplying Terminals. In case of the external power supply operation without internal power supply operation, each level of LCD driving voltage is supplied from outside fitting with following relation. $V_{DD} \geq V1 \geq V2 \geq V3 \geq V4 \geq V5 \geq V_{OUT}$</p> <p>In case of the internal power supply, LCD driving voltages V1-V4 depending on the Bias selection are supplied as shown in follows;</p> <table border="1" style="margin: 10px auto; border-collapse: collapse; text-align: center;"> <thead> <tr> <th>Bias</th> <th>V1</th> <th>V2</th> <th>V3</th> <th>V4</th> </tr> </thead> <tbody> <tr><td>1/4Bias</td><td>$V5+3/4V_{LCD}$</td><td>$V5+2/4V_{LCD}$</td><td>$V5+2/4V_{LCD}$</td><td>$V5+1/4V_{LCD}$</td></tr> <tr><td>1/5Bias</td><td>$V5+4/5V_{LCD}$</td><td>$V5+3/5V_{LCD}$</td><td>$V5+2/5V_{LCD}$</td><td>$V5+1/5V_{LCD}$</td></tr> <tr><td>1/6Bias</td><td>$V5+5/6V_{LCD}$</td><td>$V5+4/6V_{LCD}$</td><td>$V5+2/6V_{LCD}$</td><td>$V5+1/6V_{LCD}$</td></tr> <tr><td>1/7Bias</td><td>$V5+6/7V_{LCD}$</td><td>$V5+5/7V_{LCD}$</td><td>$V5+2/7V_{LCD}$</td><td>$V5+1/7V_{LCD}$</td></tr> <tr><td>1/8Bias</td><td>$V5+7/8V_{LCD}$</td><td>$V5+6/8V_{LCD}$</td><td>$V5+2/8V_{LCD}$</td><td>$V5+1/8V_{LCD}$</td></tr> <tr><td>1/9Bias</td><td>$V5+8/9V_{LCD}$</td><td>$V5+7/9V_{LCD}$</td><td>$V5+2/9V_{LCD}$</td><td>$V5+1/9V_{LCD}$</td></tr> <tr><td>1/10Bias</td><td>$V5+9/10V_{LCD}$</td><td>$V5+8/10V_{LCD}$</td><td>$V5+2/10V_{LCD}$</td><td>$V5+1/10V_{LCD}$</td></tr> <tr><td>1/11Bias</td><td>$V5+10/11V_{LCD}$</td><td>$V5+9/11V_{LCD}$</td><td>$V5+2/11V_{LCD}$</td><td>$V5+1/11V_{LCD}$</td></tr> <tr><td>1/12Bias</td><td>$V5+11/12V_{LCD}$</td><td>$V5+10/12V_{LCD}$</td><td>$V5+2/12V_{LCD}$</td><td>$V5+1/12V_{LCD}$</td></tr> </tbody> </table> <p>($V_{LCD}=V_{DD}-V5$)</p>	Bias	V1	V2	V3	V4	1/4Bias	$V5+3/4V_{LCD}$	$V5+2/4V_{LCD}$	$V5+2/4V_{LCD}$	$V5+1/4V_{LCD}$	1/5Bias	$V5+4/5V_{LCD}$	$V5+3/5V_{LCD}$	$V5+2/5V_{LCD}$	$V5+1/5V_{LCD}$	1/6Bias	$V5+5/6V_{LCD}$	$V5+4/6V_{LCD}$	$V5+2/6V_{LCD}$	$V5+1/6V_{LCD}$	1/7Bias	$V5+6/7V_{LCD}$	$V5+5/7V_{LCD}$	$V5+2/7V_{LCD}$	$V5+1/7V_{LCD}$	1/8Bias	$V5+7/8V_{LCD}$	$V5+6/8V_{LCD}$	$V5+2/8V_{LCD}$	$V5+1/8V_{LCD}$	1/9Bias	$V5+8/9V_{LCD}$	$V5+7/9V_{LCD}$	$V5+2/9V_{LCD}$	$V5+1/9V_{LCD}$	1/10Bias	$V5+9/10V_{LCD}$	$V5+8/10V_{LCD}$	$V5+2/10V_{LCD}$	$V5+1/10V_{LCD}$	1/11Bias	$V5+10/11V_{LCD}$	$V5+9/11V_{LCD}$	$V5+2/11V_{LCD}$	$V5+1/11V_{LCD}$	1/12Bias	$V5+11/12V_{LCD}$	$V5+10/12V_{LCD}$	$V5+2/12V_{LCD}$	$V5+1/12V_{LCD}$
Bias	V1	V2	V3	V4																																																	
1/4Bias	$V5+3/4V_{LCD}$	$V5+2/4V_{LCD}$	$V5+2/4V_{LCD}$	$V5+1/4V_{LCD}$																																																	
1/5Bias	$V5+4/5V_{LCD}$	$V5+3/5V_{LCD}$	$V5+2/5V_{LCD}$	$V5+1/5V_{LCD}$																																																	
1/6Bias	$V5+5/6V_{LCD}$	$V5+4/6V_{LCD}$	$V5+2/6V_{LCD}$	$V5+1/6V_{LCD}$																																																	
1/7Bias	$V5+6/7V_{LCD}$	$V5+5/7V_{LCD}$	$V5+2/7V_{LCD}$	$V5+1/7V_{LCD}$																																																	
1/8Bias	$V5+7/8V_{LCD}$	$V5+6/8V_{LCD}$	$V5+2/8V_{LCD}$	$V5+1/8V_{LCD}$																																																	
1/9Bias	$V5+8/9V_{LCD}$	$V5+7/9V_{LCD}$	$V5+2/9V_{LCD}$	$V5+1/9V_{LCD}$																																																	
1/10Bias	$V5+9/10V_{LCD}$	$V5+8/10V_{LCD}$	$V5+2/10V_{LCD}$	$V5+1/10V_{LCD}$																																																	
1/11Bias	$V5+10/11V_{LCD}$	$V5+9/11V_{LCD}$	$V5+2/11V_{LCD}$	$V5+1/11V_{LCD}$																																																	
1/12Bias	$V5+11/12V_{LCD}$	$V5+10/12V_{LCD}$	$V5+2/12V_{LCD}$	$V5+1/12V_{LCD}$																																																	
44,45 42,43 40,41 38,39 36,37	C1+,C1- C2+,C2- C3+,C3- C4+,C4- C5+,C5-	O	Capacitor connecting terminals for Internal Voltage Booster. Boosting time is programmed by instruction (2 to 6 times)																																																		
35	VOUT	O	Boosted voltage output terminal. Connects the capacitor between VOUT terminal and VSS.																																																		
47	VR	I	VLCD voltage adjustment terminal. The gain of VLCD setup circuit for V5 level is adjusted by external resistors.																																																		
19 18	T1 T2	I	<p>LCD bias voltage control terminals.</p> <table border="1" style="margin: 10px auto; border-collapse: collapse; text-align: center;"> <thead> <tr> <th>T1</th> <th>T2</th> <th>Voltage booster Cir.</th> <th>Voltage Adj.</th> <th>V/F Cir.</th> </tr> </thead> <tbody> <tr><td>L</td><td>L/H</td><td>Available</td><td>Available</td><td>Available</td></tr> <tr><td>H</td><td>L</td><td>Not Avail.</td><td>Available</td><td>Available</td></tr> <tr><td>H</td><td>H</td><td>Not Avail.</td><td>Not Avail.</td><td>Available</td></tr> </tbody> </table>	T1	T2	Voltage booster Cir.	Voltage Adj.	V/F Cir.	L	L/H	Available	Available	Available	H	L	Not Avail.	Available	Available	H	H	Not Avail.	Not Avail.	Available																														
T1	T2	Voltage booster Cir.	Voltage Adj.	V/F Cir.																																																	
L	L/H	Available	Available	Available																																																	
H	L	Not Avail.	Available	Available																																																	
H	H	Not Avail.	Not Avail.	Available																																																	
26 to 33	D0 to D7 (SI) (SCL)	I/O	<p>Data Input/Output terminals.</p> <p>In Pararel Interface Mode (P/S="H") I/O terminals of 8-bit bus.</p> <p>In Serial Interface Mode (P/S="L") D7: Input terminal of serial data (SI). D6: Input terminal of serial data clock (SCL). D0 to D5 terminals are Hi-impedance. When \overline{CS}="H", D0 to D7 terminals are Hi-impedance.</p>																																																		
23	A0	I	<p>Data discremination signal input terminal. The signal from MPU discreminates transmitted data between Display data and Instruction.</p> <table border="1" style="margin: 10px auto; border-collapse: collapse; text-align: center;"> <thead> <tr> <th>A0</th> <th>H</th> <th>L</th> </tr> </thead> <tbody> <tr> <td>Distin.</td> <td>Display Data</td> <td>Instruction</td> </tr> </tbody> </table>	A0	H	L	Distin.	Display Data	Instruction																																												
A0	H	L																																																			
Distin.	Display Data	Instruction																																																			
16	\overline{RES}	I	Reset terminal. Reset operation is executing during "L" state of \overline{RES} .																																																		
22	\overline{CS}	I	Chip select signal input terminal. Data Input/Output are available during \overline{CS} ="L".																																																		

No	Symbol	I/O	Function																				
25	\overline{RD} (E)	I	RD(80 type) or E(68 type) signal input terminal. <In 80 type MPU mode >(SEL68="L") RD signal from 80 type MPU input terminal. Active "L". D0 to D7 terminals are output during "L" level. <In 68 type MPU mode >(SEL68="H") Enable signal from 68 type MPU input terminal. Active "H".																				
24	\overline{WR} (RW)	I	WR(80 type) or R/W(68 type) signal input terminal <In 80 type MPU mode >(SEL68="L") WR signal from 80 type MPU input terminal. Active "L". The data transmitted during WR="L" are fetched at the rising edge of \overline{WR} . <In 68 type MPU mode > (SEL68="H") R/W signal from 68 type MPU input terminal. <table border="1" style="margin: 10px auto; border-collapse: collapse;"> <tr> <td style="padding: 2px;">R/W</td> <td style="padding: 2px;">H</td> <td style="padding: 2px;">L</td> </tr> <tr> <td style="padding: 2px;">State</td> <td style="padding: 2px;">Read</td> <td style="padding: 2px;">Write</td> </tr> </table>	R/W	H	L	State	Read	Write														
R/W	H	L																					
State	Read	Write																					
15	SEL68	I	MPU interface type selection terminal. This terminal must connect to V _{DD} or V _{SS} . <table border="1" style="margin: 10px auto; border-collapse: collapse;"> <tr> <td style="padding: 2px;">SEL68</td> <td style="padding: 2px;">H</td> <td style="padding: 2px;">L</td> </tr> <tr> <td style="padding: 2px;">State</td> <td style="padding: 2px;">68 Type</td> <td style="padding: 2px;">80 Type</td> </tr> </table>	SEL68	H	L	State	68 Type	80 Type														
SEL68	H	L																					
State	68 Type	80 Type																					
14	P/S	I	Parallel or Serial interface selection signal input terminal. <table border="1" style="margin: 10px auto; border-collapse: collapse;"> <tr> <th style="padding: 2px;">P/S</th> <th style="padding: 2px;">Chip Select</th> <th style="padding: 2px;">Data/Command</th> <th style="padding: 2px;">Data</th> <th style="padding: 2px;">Read/Write</th> <th style="padding: 2px;">serial Clock</th> </tr> <tr> <td style="padding: 2px;">"H"</td> <td style="padding: 2px;">\overline{CS}</td> <td style="padding: 2px;">A</td> <td style="padding: 2px;">D0 to D7</td> <td style="padding: 2px;">$\overline{RD}, \overline{WR}$</td> <td style="padding: 2px;">-</td> </tr> <tr> <td style="padding: 2px;">"L"</td> <td style="padding: 2px;">\overline{CS}</td> <td style="padding: 2px;">A0</td> <td style="padding: 2px;">SI(D7)</td> <td style="padding: 2px;">-</td> <td style="padding: 2px;">SCL(D6)</td> </tr> </table> <p style="margin-top: 10px;">In case of serial interface(P/S="L") RAM data and status read operation do not work in mode of the serial interface. RD and WR terminals must fix to "H" or "L". D0 to D5 terminals are Hi-impedance.</p>	P/S	Chip Select	Data/Command	Data	Read/Write	serial Clock	"H"	\overline{CS}	A	D0 to D7	$\overline{RD}, \overline{WR}$	-	"L"	\overline{CS}	A0	SI(D7)	-	SCL(D6)		
P/S	Chip Select	Data/Command	Data	Read/Write	serial Clock																		
"H"	\overline{CS}	A	D0 to D7	$\overline{RD}, \overline{WR}$	-																		
"L"	\overline{CS}	A0	SI(D7)	-	SCL(D6)																		
20 21	OSC1 OSC2	I	External clock input terminal. In Internal oscillation operation, OSC1 and OSC2 terminals should be Open. In External clock operation, the external clock input to OSC1 terminal.																				
62 to 125	C0 to C63	O	LCD driving signal output terminals. Common output terminals:C 0 to C127 Segment output terminals:S 0 to S131 Common output terminal Following output voltage is selected by the combination of alternating (FR) signal and Common scanning data. <table border="1" style="margin: 10px auto; border-collapse: collapse;"> <tr> <th style="padding: 2px;">Scan data</th> <th style="padding: 2px;">FR</th> <th colspan="2" style="padding: 2px;">Output Voltage</th> </tr> <tr> <td rowspan="2" style="padding: 2px;">H</td> <td style="padding: 2px;">H</td> <td colspan="2" style="padding: 2px;">V₅</td> </tr> <tr> <td style="padding: 2px;">L</td> <td colspan="2" style="padding: 2px;">V_{DD}</td> </tr> <tr> <td rowspan="2" style="padding: 2px;">L</td> <td style="padding: 2px;">H</td> <td colspan="2" style="padding: 2px;">V₁</td> </tr> <tr> <td style="padding: 2px;">L</td> <td colspan="2" style="padding: 2px;">V₄</td> </tr> </table>	Scan data	FR	Output Voltage		H	H	V ₅		L	V _{DD}		L	H	V ₁		L	V ₄			
Scan data	FR	Output Voltage																					
H	H	V ₅																					
	L	V _{DD}																					
L	H	V ₁																					
	L	V ₄																					
126 to 257	S0 to S131	O	Segment output terminal Following output voltage is selected by the combination of alternating (FR) signal and display data in the DD RAM. <table border="1" style="margin: 10px auto; border-collapse: collapse;"> <tr> <th rowspan="2" style="padding: 2px;">RAM Data</th> <th rowspan="2" style="padding: 2px;">FR</th> <th colspan="2" style="padding: 2px;">Output Voltage</th> </tr> <tr> <th style="padding: 2px;">Normal</th> <th style="padding: 2px;">Reverse</th> </tr> <tr> <td rowspan="2" style="padding: 2px;">H</td> <td style="padding: 2px;">H</td> <td style="padding: 2px;">V_{DD}</td> <td style="padding: 2px;">V₂</td> </tr> <tr> <td style="padding: 2px;">L</td> <td style="padding: 2px;">V₅</td> <td style="padding: 2px;">V₃</td> </tr> <tr> <td rowspan="2" style="padding: 2px;">L</td> <td style="padding: 2px;">H</td> <td style="padding: 2px;">V₂</td> <td style="padding: 2px;">V_{DD}</td> </tr> <tr> <td style="padding: 2px;">L</td> <td style="padding: 2px;">V₃</td> <td style="padding: 2px;">V₅</td> </tr> </table>	RAM Data	FR	Output Voltage		Normal	Reverse	H	H	V _{DD}	V ₂	L	V ₅	V ₃	L	H	V ₂	V _{DD}	L	V ₃	V ₅
RAM Data	FR	Output Voltage																					
		Normal	Reverse																				
H	H	V _{DD}	V ₂																				
	L	V ₅	V ₃																				
L	H	V ₂	V _{DD}																				
	L	V ₃	V ₅																				
321 to 258	C64 to C127	O	<table border="1" style="margin: 10px auto; border-collapse: collapse;"> <tr> <th rowspan="2" style="padding: 2px;">RAM Data</th> <th rowspan="2" style="padding: 2px;">FR</th> <th colspan="2" style="padding: 2px;">Output Voltage</th> </tr> <tr> <th style="padding: 2px;">Normal</th> <th style="padding: 2px;">Reverse</th> </tr> <tr> <td rowspan="2" style="padding: 2px;">H</td> <td style="padding: 2px;">H</td> <td style="padding: 2px;">V_{DD}</td> <td style="padding: 2px;">V₂</td> </tr> <tr> <td style="padding: 2px;">L</td> <td style="padding: 2px;">V₅</td> <td style="padding: 2px;">V₃</td> </tr> <tr> <td rowspan="2" style="padding: 2px;">L</td> <td style="padding: 2px;">H</td> <td style="padding: 2px;">V₂</td> <td style="padding: 2px;">V_{DD}</td> </tr> <tr> <td style="padding: 2px;">L</td> <td style="padding: 2px;">V₃</td> <td style="padding: 2px;">V₅</td> </tr> </table>	RAM Data	FR	Output Voltage		Normal	Reverse	H	H	V _{DD}	V ₂	L	V ₅	V ₃	L	H	V ₂	V _{DD}	L	V ₃	V ₅
RAM Data	FR	Output Voltage																					
		Normal	Reverse																				
H	H	V _{DD}	V ₂																				
	L	V ₅	V ₃																				
L	H	V ₂	V _{DD}																				
	L	V ₃	V ₅																				

■ Functional Description

(1) Description for each blocks

(1-1) Busy Flag (BF)

The Busy Flag (BF) is set to logical "1" in busy of internal execution by an instruction, and any instruction excepting for the "Status Read" is disable at this time. Busy Flag is outputted through D7 terminal by "Status Read" instruction. Although another instructions should be inputted after check of Busy Flag, no need to check Busy flag if the system cycle time (tCYC) as shown in ■AC Characteristics is secured completely.

(1-2) Display Start Line Register

The Display Start Line Register is a register to set a display data RAM address corresponding to the COM₀ display line (the top line normally) for the vertical scroll on the LCD, Page address change and so forth. The Display Start Line Address set instruction sets the 8-bit display start address into this register.

(1-3) Line Counter

Line Counter is reset when the internal FR signal is switched and outputs the line address of the display data RAM by count up operation synchronizing with common cycle of **NJU6679**.

(1-4) Column Address Counter

Column Address Counter is the 8-bit preset-able counter to point the column address of the display data RAM (DD RAM) as shown in Figure 1. The counter is incremented automatically after the display data read/write instructions execution. When the Column address counter reaches to the maximum existing address by the increment operations, the count up operation (increment) is frozen. However, when new address is set to the column address counter again, it restarts the count up operation from a set address. The operation of Column Address Counter is independent against Page Address Register.

By the address inverse instruction (ADC select) as shown in Figure 1, Column Address Decoder reverses the correspondence between Column address and Segment output of display data RAM.

(1-5) Page address Register

Page Address Register assigns the page address of the display data RAM as shown in Figure 1. In case of accessing from the MPU with changing the page address, Page Address Set instruction is required.

(1-6) Display Data RAM

The Display data RAM (DD RAM) is the bit map RAM consisting of 25,344 bits to store the display data corresponding to the LCD pixel on LCD panel.

The DD RAM data and the state of the LCD:

In Normal Display : "1"=Turn-On Display, "0" =Turn-Off Display

In Reverses Display : "1"=Turn-Off Display, "0" =Turn-On Display

DD RAM output 132 bits parallel data addressed by line address counter then the data latched in the display data latch. Asynchronous data access to the DD RAM is available due to the access to the DD RAM from the CPU and latch to the display data latch operation are done independently.

(1-7) Common Driver Assignment

This circuit determines the scanning direction of the common output.

Table 1

		COM Outputs Terminals			
PAD No.	62	125	258	321	
Pin name	C ₀	C ₆₃	C ₁₂₇	C ₆₄	
Ver.A	COM ₀	→COM ₆₃	COM ₁₂₇ ←	COM ₆₄	
Ver.B	COM ₁₂₇ ←	COM ₆₄	COM ₀	→COM ₆₃	

The Mask fixes the common scanning direction between version A and B that can not be changed by the instruction.

Page Address	DATA	Display Pattern	Line Address
D4,D3,D2,D1,D0 (0,0,0,0,0)	D0		00
	D1		01
	D2		02
	D3		03
	D4		04
	D5		05
	D6		06
	D7		07
D4,D3,D2,D1,D0 (0,0,0,0,1)	D0		08
	D1		09
	D2		0A
	D3		0B
	D4		0C
	D5		0D
	D6		0E
	D7		0F
D4,D3,D2,D1,D0 (0,0,0,1,0)	D0		10
	D1		11
	D2		12
	D3		13
	D4		14
	D5		15
	D6		16
	D7		17
D4,D3,D2,D1,D0 (1,0,0,0,1)	D0		88
	D1		89
	D2		8A
	D3		8B
	D4		8C
	D5		8D
	D6		8E
	D7		8F
D4,D3,D2,D1,D0 (1,0,1,1,1)	D0		B8
	D1		B9
	D2		BA
	D3		BB
	D4		BC
	D5		BD
	D6		BE
	D7		BF

For example the Display start line is 10H

Cn Out
C0
C1
C2
C3
C4
C5
C6
C7
C8
C9
...
C118
C119
C120
C121
C122
C123
C124
C125
C126
C127

Column Address	A D C	D0="0"	00	01	02	03	04	05	06	07	08	09	7A	7B	7C	7D	7E	7F	80	81	82	83
		D0="1"	83	82	81	80	7F	7E	7D	7C	7B	7A	09	08	07	06	05	04	03	02	01	00
Segment Output		0	1	2	3	4	5	6	7	8	9	122	123	124	125	126	127	128	129	130	131	

Fig.1 Correspondence with Display Data RAM Address

(1-8) Reset Circuit

When the input signal to $\overline{\text{RES}}$ terminal goes to "L", the reset circuit executes initialization as below;

The Initialization state (default)

- 1 Display Off
- 2 Normal Display (not inverse)
- 3 ADC Select : Normal (ADC Instruction D₀ ="0")
- 4 Read Modify Write Mode Off
- 5 Voltage Booster off, Voltage Regulator off, Voltage follower off
- 6 Static Drive Off
- 7 Driver Output Off
- 8 Clear the data of serial interface register
- 9 Set the Column Address Counter to 00H
- 10 Set the Display Start Line Register to 00H
- 11 Set the Page Address Register to page "0"
- 12 Set the EVR register to FFH
- 13 Set the Partial Display(1/128 duty)
- 14 Set the Bias select(1/12 Bias)
- 15 Set the Voltage Booster(6 times)
- 16 Set the n-line inverse register to 0H

The $\overline{\text{RES}}$ terminal connects to the reset terminal of the MPU synchronization with the MPU initialization as shown in "the MPU interface" in the Application Circuit section. The "L" level input signal as reset signal must keep the period over than 10 μ s as shown in DC Characteristics. The NJU6679 takes 1 μ s for the reset operation after the rising edge of the $\overline{\text{RES}}$ signal.

The reset operation by $\overline{\text{RES}} = \text{"L"}$ initializes each register setting as above reset status, but the internal oscillation circuit and output terminals (D₀ to D₇) are not affected.

To avoid the lock-up, the reset operation by the $\overline{\text{RES}}$ terminal must be required every time when power turns on.

The reset operation by the reset instruction, function 9 to 16 operations mentioned above is performed.

The $\overline{\text{RES}}$ terminal must be keep "L" level when the power turns on in not use of the built-in LCD power supply circuit for no affect to the internal execution.

(1-9) LCD Driving Circuit

(a) LCD Driving Circuits

LCD driver is 260 sets of multiplexer consisting of 132 segments and 128 commons drivers to output LCD driving voltage. The common driver outputs the common scan signals formed with the shift register. The segment driver outputs the segment driving signal determined by a combination of display data in the DD RAM, common timing, FR signal, and alternating signal for LCD. The output wave forms of segment/common are shown in **LCD DRIVING WAVEFORM**.

(b) Display Data Latch Circuits

Display Data Latch Circuit latches the 132-bit display data outputted from the DD RAM addressed by the Line address counter to LCD driver at every common signal cycle temporarily. The original data in the DD RAM is not changed because of the Normal/Reverse display, Display On/Off, Static drive On/Off instruction processes only stored data in this Display Data Latch Circuit.

(c) Signal forming to Line Counter and Display Data Latch Circuit

The count clock to Line Counter and the latch clock to Display Data Latch Circuit are formed using the internal display clock (CL). The display data of 132 bits from Display Data RAM pointed by the line address synchronizing with the internal display clock are latched into the Display Data Latch Circuit and are outputted to LCD driving circuits.

The display data read out operation from DD RAM to the LCD Driver Circuit is completely independent operation with an access to the display data RAM from MPU.

(d) Display Timing Generation Circuit

The display timing generation circuit generates the internal timing of the display system by the master clock and the internal FR signal. As for it, the internal FR signal and the LCD alternating signal generate the wave form of 2-frame alternating drive wave form or the n-line inverse drive method for the LCD Driving circuit.

(e) Common Timing Generator

The Common Timing Generator generates the common timing signal from the display clock (CL).

-2-frame alternating drive mode

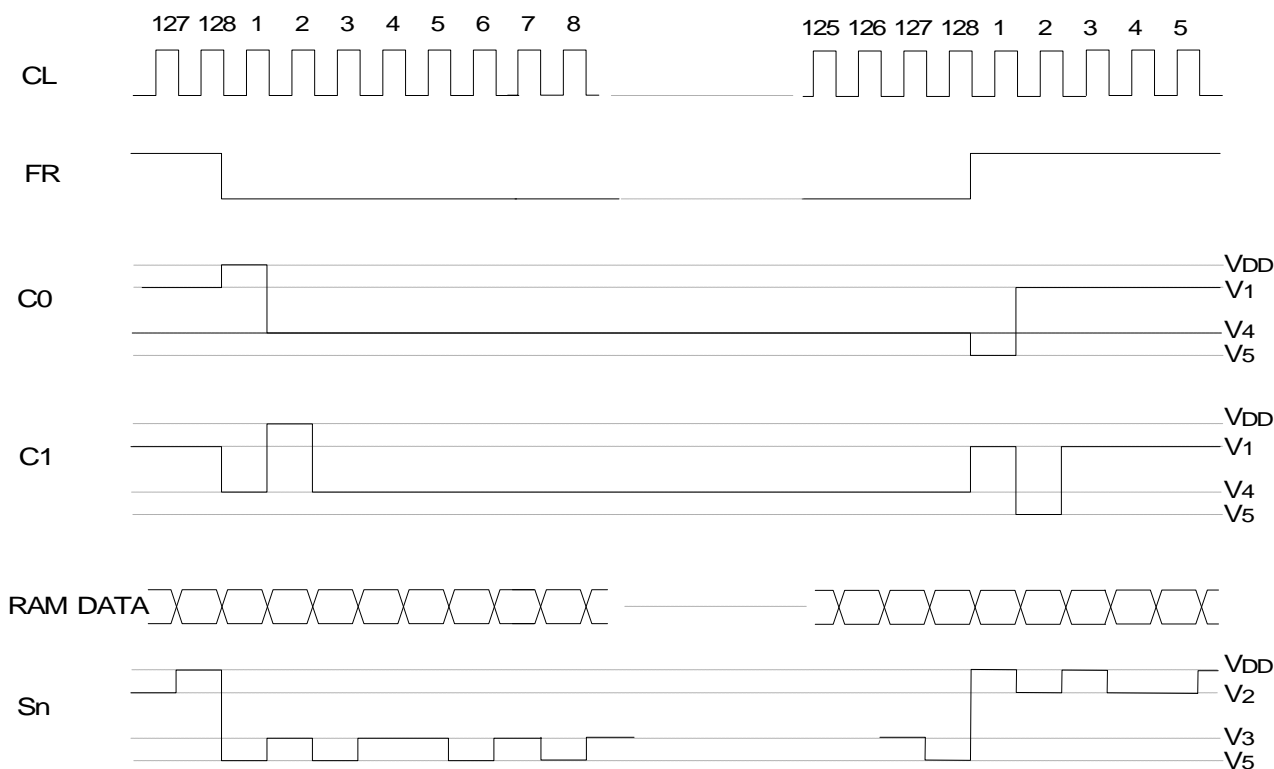

Fig.2

-n-line inverse drive mode (n=7, line inverting register sets to 6)

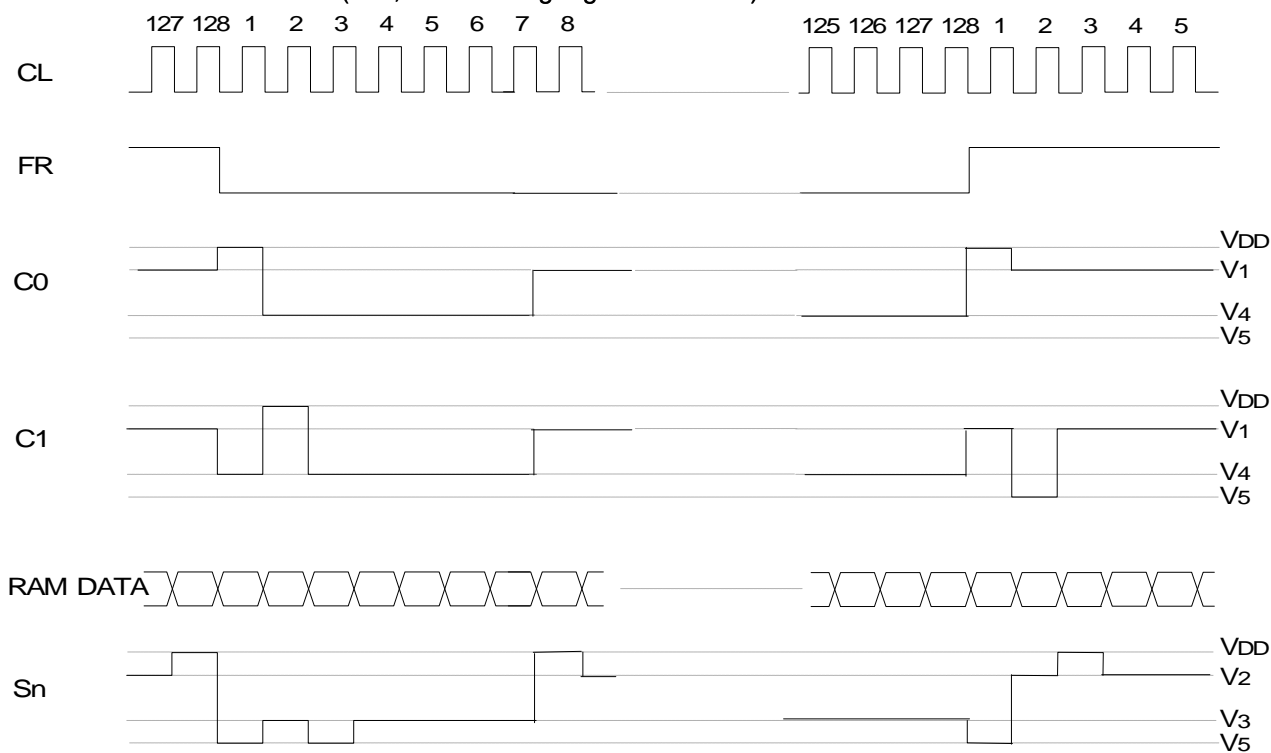

Fig.3

(f) Oscillation Circuit

The Oscillation Circuit is a low power type CR oscillator using an internal resistor and capacitor. The oscillator output is using for the display timing clock and for the voltage booster circuit. And the display clock(CL) is generated from this oscillator output frequency by dividing.

-The relation between duty and divide

Table 2

Duty	1/8	1/16	1/24	1/32	1/40	1/48	1/56	1/64	1/72	1/80,88	1/96,104	1/112,120,128
Divide	1/64	1/32	1/21	1/16	1/12	1/10	1/9	1/8	1/7	1/6	1/5	1/4

(g) Power Supply Circuit

The internal power supply circuit generates the voltage for driving LCD. It consists of voltage booster circuits (from 2 times to 6 times), voltage regulator circuits, and voltage followers.

The operation of internal Power Supply Circuits is controlled by the Internal Power Supply On/Off Instruction. When the Internal Power Supply Off Instruction is executed, all of the voltage booster circuits, regulator circuits, voltage follower circuits are turned off. In this time, the bias voltage of V1, V2, V3, V4, V5 and VOUT for the LCD should be supplied from outside, terminals C1+, C1-, C2+, C2-, C3+, C3-, C4+, C4-, C5+, C5-, and VR should be open. The status of internal power supply is selected by T1 and T2 terminal. Furthermore the external power supply operates with some of internal power supply function.

Table 3

T1	T2	Voltage Booster	Voltage Adj.	Buffer(V/F)	Ext.Pow Supply	C1+,C1- to C5+,C5-	VR Term.
L	L/H	ON	ON	ON	-		
H	L	OFF	ON	ON	VOUT	Open	
H	H	OFF	OFF	ON	V5,VOUT	Open	Open

When (T1, T2)=(H, L), C1+, C1-, C2+, C2-, C3+, C3-, C4+, C4-, C5+, C5- terminals for voltage booster circuits are open because the voltage booster circuits doesn't operate. Therefore LCD driving voltage to the VOUT terminal should be supplied from outside.

When (T1, T2)=(H, H), terminals for voltage booster circuits and VR are open, because the voltage booster circuits and Voltage adjust circuits do not operate.

The internal power supply Circuits is designed specially for a small-size LCD like as normal cellular phone size LCD panel. When **NJU6679** apply to the large size LCD panel application (large capacitive load), external power supply is required to keep good display condition..

To keep good display condition, external component of the capacitors connecting to the V1 to V5 terminals and voltage booster circuits and the feedback resistors for the V5 operational amplifier must fix each optimized constant after checking various display patterns on LCD panel actually in the application.

○Power Supply applications

(1) Internal Power Supply Example.

All of the Internal Booster, Voltage Regulator, Voltage Follower using.

Internal power supply ON (instruction) (T1,T2)=(L,L)

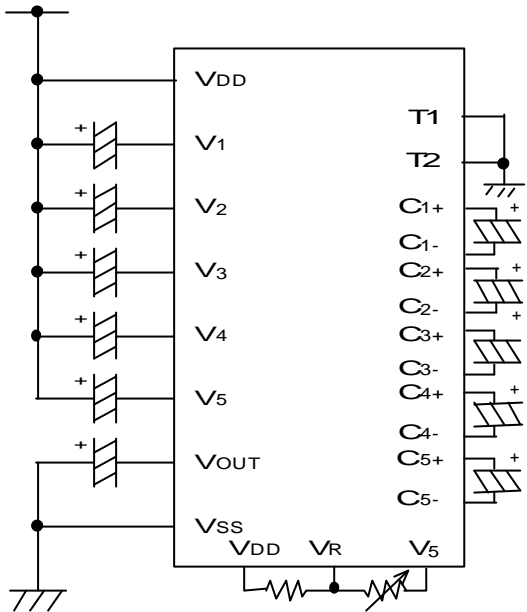

(2) Only VOUT Supply from outside Example.

Internal Voltage Regulator, Voltage Follower using Internal power supply ON (Instruction) (T1,T2) = (H,L)

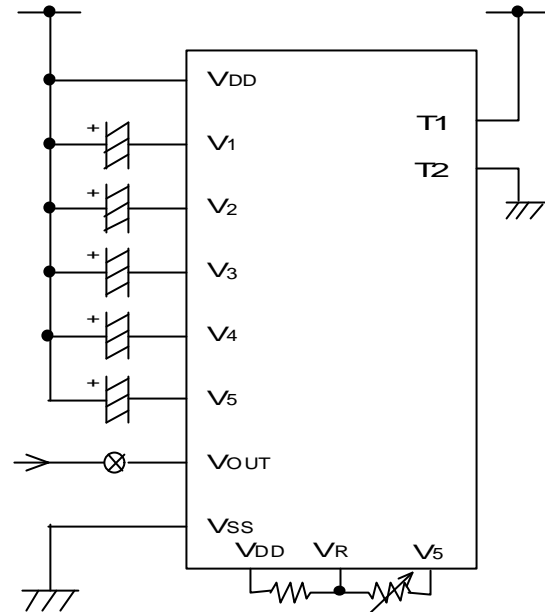

(3) VOUT and V5 supply from outside Example.

Internal Voltage Follower using.

Internal power supply (Instruction) (T1,T2) =(H,H)

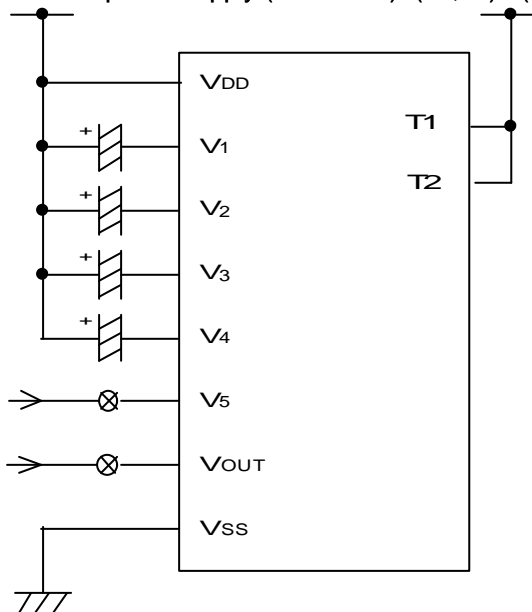

(4) External Power Supply Example

All of V1 to V5 and VOUT supply from outside

Internal power supply (Instruction) (T1,T2) =(H,H)

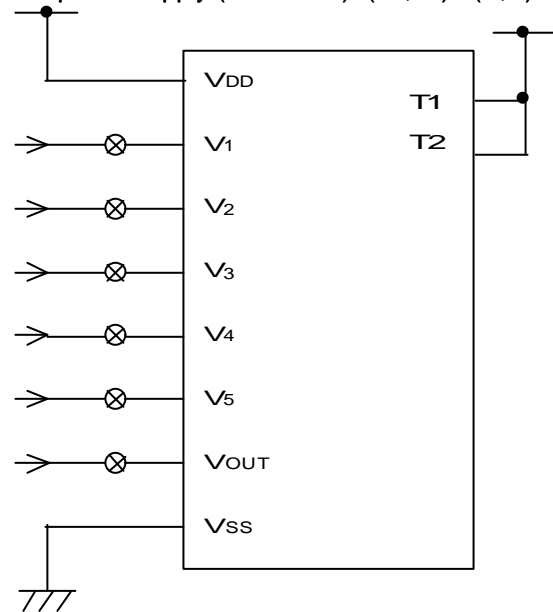

⊗ : These switches should be open during the power save mode.

(2) Instruction

The **NJU6679** distinguishes the data on the data bus D0 to D7 as an instruction by combination of A0, \overline{RD} , and \overline{WR} (R/W) signals. The decoding of the instruction and execution performs with only high speed internal timing without relation to the external clock. Therefore, no busy flag check required normally. In case of the serial interface, the data input as MSB(D7) first serially. Table.4 shows the instruction codes of the **NJU6679**.

Table 4. Instruction Code

(*:Don't Care)

Instruction	Code											Description	
	A0	\overline{RD}	\overline{WR}	D7	D6	D5	D4	D3	D2	D1	D0		
(a) Display ON/OFF	0	1	0	1	0	1	0	1	1	1	0/1	LCD Display ON/OFF 0:OFF 1:ON	
(b) Display Start Line Set	Display Start Line Set High Order 4bits	0	1	0	0	1	0	1	High Order Address			Determine the Display Line of RAM to the COM0. (Set the Higher order 4bits)	
	Display Start Line Set Lower Order 4bits	0	1	0	0	1	1	0	Lower Order Address			Determine the Display Line of RAM to the COM0. (Set the Lower order 4bits)	
(c) Page Address Set	Page Address Set High Order 1bits	0	1	0	0	1	0	0	*	*	*	Hi.	Set the Higher order 1bit page of DD RAM to the Page Address Register
	Page Address Set Lower Order 4bits	0	1	0	1	1	0	0	Lower Order Page Address			Set the Lower order 4 bit page of DD RAM to the Page Address Register	
(d) Column Address Set	Column Address Set High Order 4bits	0	1	0	0	0	0	1	High Order Column Add.			Set the Higher order 4 bits Column Address to the Reg.	
	Column Address Set Lower Order 4bits	0	1	0	0	0	0	0	Lower Order Column Add.			Set the Lower order 4 bits Column Address to the Reg.	
(e) Status Read	0	0	1	Status				0	0	0	0	Read out the internal Status	
(f) Write Display Data	1	1	0	Write Data							Write the data into the Display Data RAM		
(g) Read Display Data	1	0	1	Read Data							Read the data from the Display Data RAM		
(h) Normal or Inverse ON/OFF Set	0	1	0	1	0	1	0	0	1	1	0/1	Inverse the ON and OFF Display 0:Normal 1:Inverse	
(i) Static Drive ON /Normal Display	0	1	0	1	0	1	0	0	1	0	0/1	Whole Display Turns ON 0:Normal 1:Whole Disp. ON	
(j) Sub instruction table mode	0	1	0	0	1	1	1	0	0	0	0	Set the Sub instruction table.	
Sub Inst.	(k) Partial Display												
	1st Block, Set Start display unit	0	1	0	0	0	0	0	Start display unit			Set the Start display unit of 1st Block.	
	1st Block, Set The number of display units	0	1	0	0	0	1	number of display units			Set the number of display units of 1st Block.		
	2nd Block, Set Start display unit	0	1	0	1	1	0	0	Start display unit			Set the Start display unit of 2nd Block.	
	2nd Block, Set The number of display units	0	1	0	1	1	1	number of display units			Set the number of display units of 2nd Block.		
	Partial display on	0	1	0	0	1	0	0	0	0	0	0	It comes off the mode to set and a display is executed.
	(l)n-line Inverse Drive Set												
	Register Set Higher order 2 bits	0	1	0	0	1	0	1	*	*	higher order		Set the number of inverse drive line.
	Register Set Lower order 4 bits	0	1	0	0	1	1	0	Lower order			Set the number of inverse drive line.	
	n-line Inverse Drive Set is executed.	0	1	0	0	1	1	1	0	0	0	0	The execution of the line inverse drive.
	(m) EVR Register Set												
	EVR Register Set Higher order 4 bits	0	1	0	1	0	0	0	EVR Data Higher order			Set the V5 output level to the EVR register. (Higher order 4 bits)	
	EVR Register Set Lower order 4 bits	0	1	0	1	0	0	1	EVR Data Lower order			Set the V5 output level to the EVR register. (Lower order 4 bits)	
	EVR Register Set is executed.	0	1	0	1	0	1	0	0	0	0	0	The execution of the EVR.
	(n) End of sub instruction table mode	0	1	0	0	1	1	1	0	0	0	1	It ends the setting of sub instruction table.

(*:Don't Care)

Instruction		Code											Description
		A0	\overline{RD}	\overline{WR}	D7	D6	D5	D4	D3	D2	D1	D0	
(o)	Bias Select	0	1	0	1	0	1	1	Bias				Select the bias (9 Patterns)
(p)	Boost Level Select	0	1	0	0	0	1	1	0	Boost Multiple			Set the Booster circuits
(q)	Read Modify Write /End	0	1	0	1	1	1	0	0	0	0	0/1	Read Modify Write mode D0=0:On D0=1:End
(r)	Reset	0	1	0	1	1	1	0	0	0	1	0	Initialize the internal Circuits
(s)	Internal Power Supply ON/OFF	0	1	0	0	0	1	0	0	0	0	0/1	0:Int. Power Supply OFF 1:Int. Power Supply ON
(t)	Driver Outputs ON/OFF	0	1	0	0	0	1	0	0	0	1	0/1	D0=0: LCD Driver Outputs OFF D0=1: LCD Driver Outputs ON
(u)	Power Save (Complex Command)												Set the Power Save Mode (LCD Display OFF +Whole Display Turns ON)
(v)	ADC Select	0	1	0	1	0	1	0	0	0	0	0/1	Set the DD RAM vs Segment D0=0:Normal D0=1:Inverse

(2-1) Explanation of Instruction Code

(a) Display On/Off

It executes the ON/OFF control of the whole display without relation to the DD RAM or any internal conditions.

A0	\overline{RD}	\overline{WR}	D7	D6	D5	D4	D3	D2	D1	D0
0	1	0	1	0	1	0	1	1	1	D

D 0:Display Off

1:Display On

(b) Display Start Line

It sets the DD RAM line address corresponding to the COM0 terminal (normally assigned to the top display line). In this instruction execution, the display area is automatically set by the lines that correspond to the display duty ratio to the upward direction of the line address. Changing the line address by this instruction performs smooth scrolling to a vertical direction. In this time, the DD RAM data are unchanged.

A0	\overline{RD}	\overline{WR}	D7	D6	D5	D4	D3	D2	D1	D0
0	1	0	0	1	0	1	A7	A6	A5	A4
0	1	0	0	1	1	0	A3	A2	A1	A0

A7	A6	A5	A4	A3	A2	A1	A0	Line Address(HEX)
0	0	0	0	0	0	0	0	00
0	0	0	0	0	0	0	1	01
			:					:
			:					:
1	0	1	1	1	1	1	1	BF

(c) Page Address Set

When MPU access to the DD RAM, a page address is set by page Address Set instruction before writing the data. (Note: the change of page address is not affected to the display.)

A0	\overline{RD}	\overline{WR}	D7	D6	D5	D4	D3	D2	D1	D0
0	1	0	0	1	0	0	*	*	*	A4
0	1	0	1	1	0	0	A3	A2	A1	A0

(*:Don't Care)

A4	A3	A2	A1	A0	Page
0	0	0	0	0	0
0	0	0	0	1	1
		:			:
		:			:
1	0	1	1	1	23

(d) Column Address

When MPU accesses to the DD RAM , the row address set by Page Address Set instruction is required with the column address before writing the data. The column address set requires twice address set which are higher order 4 bits address set and lower order 4 bits.

When the MPU access to the DD RAM continuously, the column address increments automatically from the set address after each data access. Therefore, the MPU can transmit only the Data continuously without setting the column address at every transmission time. The increment of column address is stopped at the maximum column address plus 1 limited by each display mode. When the column address count up is stopped, the row address is not changed.

A 0	\overline{RD}	\overline{WR}	D 7	D 6	D 5	D 4	D 3	D 2	D 1	D 0	
0	1	0	0	0	0	1	A 7	A 6	A 5	A 4	Higher Order
0	1	0	0	0	0	0	A 3	A 2	A 1	A 0	Lower Order

A7	A6	A5	A4	A3	A2	A1	A0	Column Address(HEX)
0	0	0	0	0	0	0	0	0
0	0	0	0	0	0	0	1	1
				:				:
				:				:
1	0	0	0	0	0	1	1	83

(e) Status Read

This instruction reads out the internal status of "BUSY", "ADC", "ON/OFF" and "RESET" described as follows.

A 0	\overline{RD}	\overline{WR}	D 7	D 6	D 5	D 4	D 3	D 2	D 1	D 0
0	0	1	BUSY	ADC	ON/OFF	RESET	0	0	0	0

BUSY : BUSY=1 indicate the operating or the Reset cycle.

All instructions can be input after the BUSY status change to "0".

ADC : Indicate the output correspondence of column (segment) address and segment driver.

0 : Counterclockwise Output (Inverse)

1 : Clockwise Output (Normal)

(Note) The data "0=Inverse" and "1=Normal" of ADC status is inverted with the ADC select Instruction of "1=Inverse" and "0=Normal".

ON/OFF : Indicate the whole display On/Off status.

0 : Whole Display "On"

1 : Whole Display "Off"

(Note) The data "0=On" and "1=Off" of Display On/Off status is inverted with the Display On/Off instruction data of "1=On" and "0=Off".

RESET : Indicate the initializing by \overline{RES} terminal signal or reset instruction.

0 : Not Reset status

1 : In the Reset status

(f) Write Display Data

It writes the data on the data bus into the DD RAM. column address increments automatically after data writing, therefore, the MPU can write the data into the DD RAM continuously without the address setting at every writing time once the starting address is set.

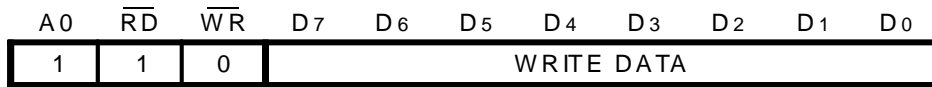

(g) Read Display Data

This instruction reads out the 8-bit data from DD RAM addressed by the column and the page address. The column address automatically increments after the 8-bit data read out, therefore, the MPU can read the data from the DD RAM continuously without the address setting at every reading time once the starting address is set. Note that the dummy read is required just after setting the column address (see "(4-4) Access to the DD RAM and the Internal Register").

In the serial interface mode, the display data is unable to read out.

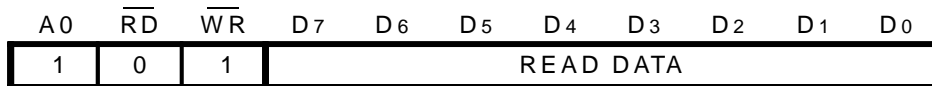

(h) Normal or Inverse On/Off Set

It changes the display condition of normal or reverse for entire display area. The execution of this instruction does not change the display data in the DD RAM.

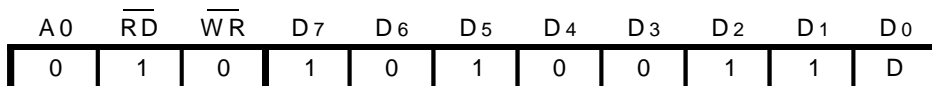

D 0 : Normal RAM data "1" correspond to "On"
 1 : Inverse RAM data "0" correspond to "On"

(i) Static Drive

This instruction turns all the pixels ON regardless the data stored in the DD RAM. In this time, the data in DD RAM are remained and unchanged. This instruction is executed prior to the "Normal or Inverse On/Off Set" Instruction.

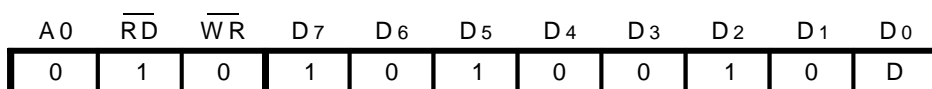

D 0 : Normal Display
 1 : Whole Display turns On

When the "Static Drive ON" instruction is executed at Display OFF status, the **NJU6679** operates in Power Save Mode. (Refer "Power Save Mode")

(j) Sub Instruction table mode

This instruction switches the instruction table from the main to the sub. The sub instruction table contains instructions of partial display, n-line inverse drive set and EVR register set as mentioned in (k), (l) and (m). The instruction of sub instruction table mode must be executed before above 3 sub instructions execution. The instruction of end of sub instruction table mode (n) switches the instruction table from the sub to the main. If any main instructions are written in the sub instruction mode, the **NJU6679** will malfunction.

A0	\overline{RD}	\overline{WR}	D7	D6	D5	D4	D3	D2	D1	D0
0	1	0	0	1	1	1	0	0	0	0

-Set sub Instruction table flow is shown below:

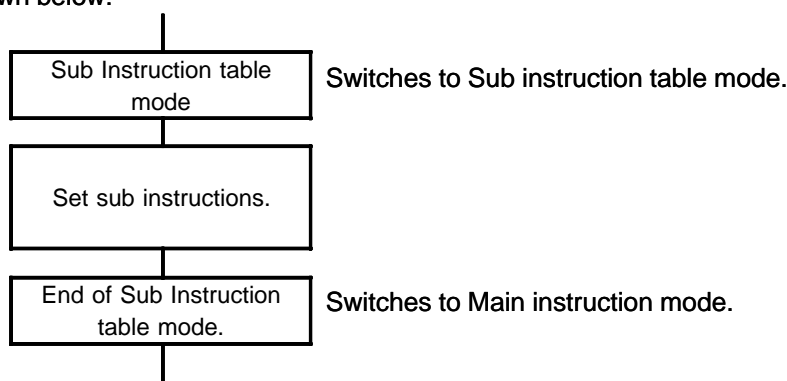

(k) Partial Display

It selects two active display areas on the LCD Panel partially. The display area is divided to 16 units with four commons each and selected two display blocks by setting Unit number and number of Unit required (not overlap, not over than 16 units) to display on the LCD panel. These two display blocks are assigned optionally on the LCD panel. Duty selects an adapted ratio number corresponding to the total number of two display blocks automatically.

Partial Display function adjusts the LCD driving voltage, Voltage boosting times and E.V.R level by the instruction to generate the optimum LCD driving voltage for display quality. As result, the operating current is reduced.

- Display Unit Structure

UNIT	0	(8 commons)							
UNIT	1								
UNIT	2								
UNIT	3								
UNIT	4								
UNIT	5								
UNIT	6								
UNIT	7								
UNIT	8								
UNIT	9								
UNIT	10								
UNIT	11								
UNIT	12								
UNIT	13								
UNIT	14								
UNIT	15	(8 commons)							

128-common

132-segment

Partial display instruction

When Partial Display functions, both of Top Unit Number of display area (the Start Unit) and the number of the effective continuous unit (Display Unit) from the Start Unit for the first display block and the second. Attention that the first display block and the second definition must not be overlap of display area and not be over than 16 units in total.

In case of whole display (1/128 duty), the first display block defines Start Unit=0 (0,0,0,0) and Display Unit = 16 (1,0,0,0,0) for all of display area selection. In this time, the definition of the second display block is ignored. In case of only the first block display, the second display block defines Start Unit=0 (0,0,0,0) and Display Unit = 0 (0,0,0,0,0) for no display area.

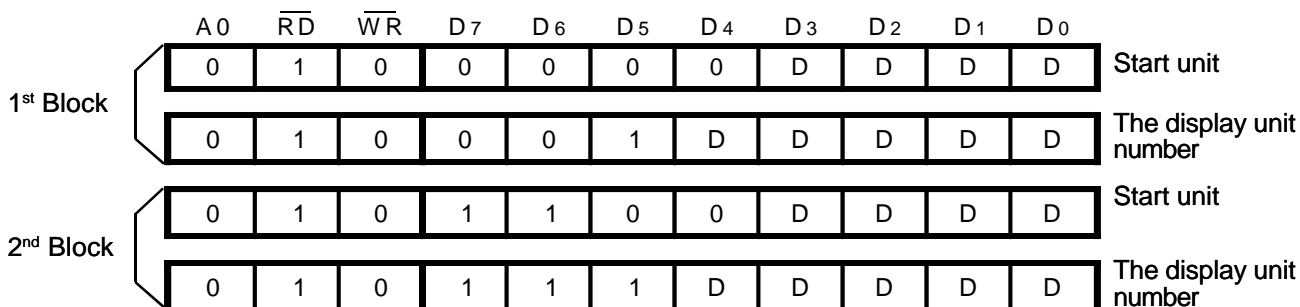

By input following instruction, the duty ratio is changed automatically and executes the partial display function.



D :unit number (Hex.)

Notes) Attention followings due to prevent from malfunction

- The input order of Partial Display instructions must follow above.
- Prohibits the overlap of the 1st partial display block and the 2nd.
- The Start Unit of the 1st partial display block must not be over 15.
- The total Display Unit Number (the sum of the 1st and 2nd partial display block Unit Number) must not be over 16.
- On the LCD panel, no active display area inserts between the 1st display block and the 2nd. However, the display data of the 1st display block and the 2nd must store continuously in the display data RAM.

Example of the Partial Display setting.

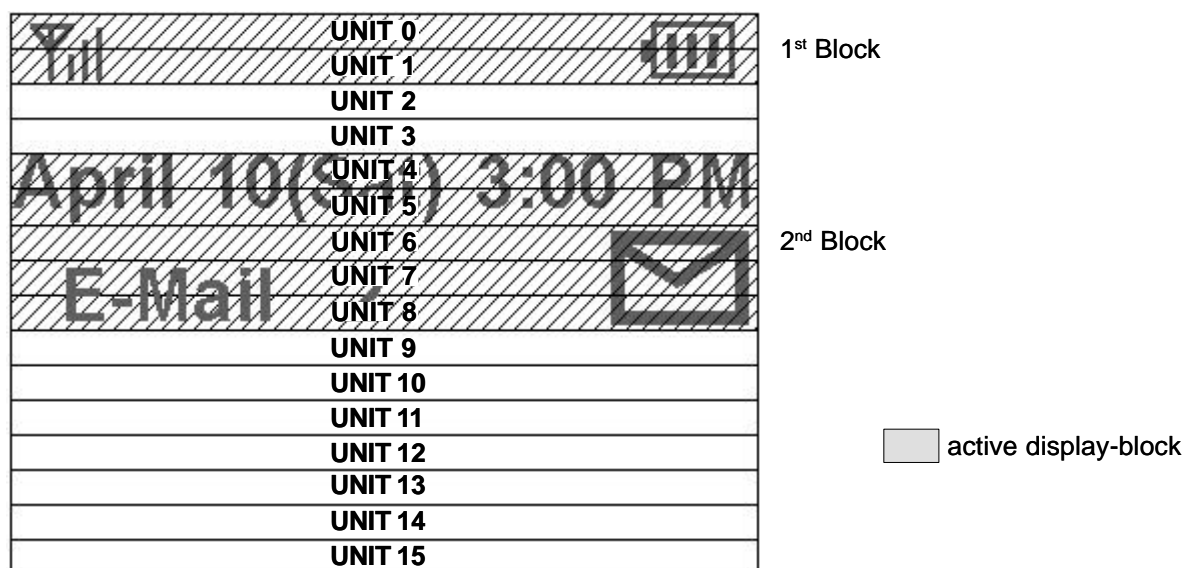

The above partial display condition is set as follows:

1) Set sub instruction mode

A0	\overline{RD}	\overline{WR}	D7	D6	D5	D4	D3	D2	D1	D0	
0	1	0	0	1	1	1	0	0	0	0	Set sub instruction mode.

2) Set partial display conditions

A0	\overline{RD}	\overline{WR}	D7	D6	D5	D4	D3	D2	D1	D0	
0	1	0	0	0	0	0	0	0	0	0	1 st Block, Set start unit to "0"
0	1	0	0	0	1	0	0	0	1	0	1 st Block, Set the display unit number to "2"
0	1	0	1	1	0	0	0	1	0	0	2 nd Block, Set start unit to "4"
0	1	0	1	1	1	0	0	1	0	1	2 nd Block, Set the display units number to "5"
0	1	0	0	1	0	0	0	0	0	0	Execute Partial display.

The Duty is changed to 1/56 automatically.

3) End sub instruction mode

A0	\overline{RD}	\overline{WR}	D7	D6	D5	D4	D3	D2	D1	D0	
0	1	0	0	1	1	1	0	0	0	1	End sub instruction mode. Back to main instruction mode.

Duty is changed automatically when Partial Display execution. But LCD Driving Voltage, Bias, Driving form like as 2-frame alternating driving or n-line inverse are not changed. Therefore, Display Off should operate before Partial Display execution for prevention of unexpected display, and Voltage Booster Select instruction, E.V.R Register Set, Bias Select and n-line Inverse Driving Set should set optimum conditions for good display in the mean time of Partial Display instruction execution. The optimum conditions should fix referring the result of actual display evaluation.

-Set Partial Display flow is shown below:

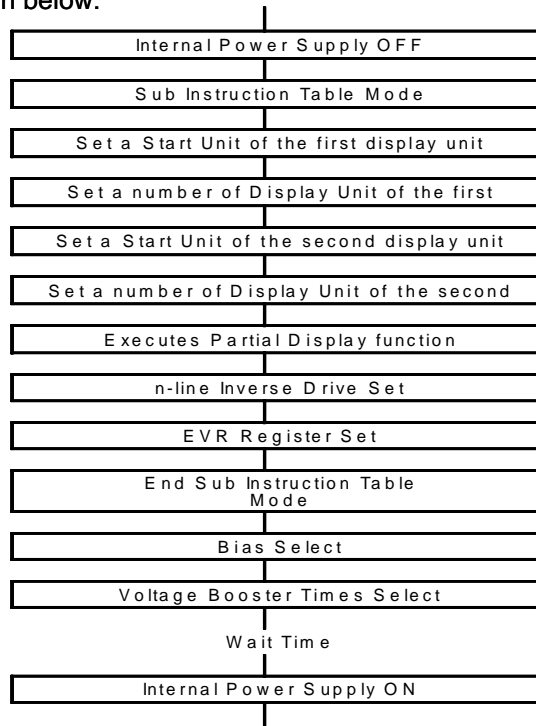

(l) n-line Inverse Drive Mode

n-Line Inverse Register Set (refer +Functional Description Fig.3 n-line Inverse alternative drive mode)

It sets a line number to inverse the polarity of common driver and segment.

The instructions must be input in order of followings. These instructions are sub instruction sets and must be set after (j)Sub instruction table mode.

1)Set sub instruction mode

A0	\overline{RD}	\overline{WR}	D7	D6	D5	D4	D3	D2	D1	D0	Set sub instruction mode.
0	1	0	0	1	1	1	0	0	0	0	

2)Set n-line Inverse number

A0	\overline{RD}	\overline{WR}	D7	D6	D5	D4	D3	D2	D1	D0	Higher order
0	1	0	0	1	0	1	*	*	A5	A4	
0	1	0	0	1	1	0	A3	A2	A1	A0	Low order

A5	A4	A3	A2	A1	A0	Inverse line	(*:2-frame alternating drive mode.)
0	0	0	0	0	0	-(*)	
0	0	0	0	0	1	2	
:						:	
1	1	1	1	1	1	64	

3)Execute the n-line Inverse

A0	\overline{RD}	\overline{WR}	D7	D6	D5	D4	D3	D2	D1	D0
0	1	0	0	1	1	1	0	0	0	0

4)End sub instruction mode

A0	\overline{RD}	\overline{WR}	D7	D6	D5	D4	D3	D2	D1	D0	End sub instruction mode. Back to main instruction mode.
0	1	0	0	1	1	1	0	0	0	1	

(m) EVR Register Set

It controls the voltage regulator circuit of the internal LCD power supply to adjust the LCD display contrast by changing the LCD driving voltage "V5". By data setting into the EVR register, the LCD driving voltage "V5" selects out of 201 steps of regulated voltage. The voltage adjustable range of "V5" is fixed by the external resistors. For details, refer the section "(3-2) Voltage Adjust Circuits".

1) Set sub instruction mode

A0	\overline{RD}	\overline{WR}	D7	D6	D5	D4	D3	D2	D1	D0	Set sub instruction mode.
0	1	0	0	1	1	1	0	0	0	0	

2) Set EVR Register

A0	\overline{RD}	\overline{WR}	D7	D6	D5	D4	D3	D2	D1	D0
0	1	0	1	0	0	0	A7	A6	A5	A4
0	1	0	1	0	0	1	A3	A2	A1	A0

A7	A6	A5	A4	A3	A2	A1	A0	VLCD
0	0	1	1	0	1	1	1	Low
			⋮					⋮
1	1	1	1	1	1	1	1	High

$V_{LCD} = V_{DD} - V_5$

When EVR doesn't use, set the EVR register to (1,1,1,1,1,1,1,1).

3) Execute the EVR

A0	\overline{RD}	\overline{WR}	D7	D6	D5	D4	D3	D2	D1	D0
0	1	0	1	0	1	0	0	0	0	0

4) End sub instruction mode

A0	\overline{RD}	\overline{WR}	D7	D6	D5	D4	D3	D2	D1	D0	End sub instruction mode. Back to main instruction mode.
0	1	0	0	1	1	1	0	0	0	1	

(n) End of Sub instruction table mode

"End of sub instruction table mode" instruction switches instruction table from sub to main.

(k) Partial display, (l) n-line inverse drive mode, and (m) EVR are sub instruction sets on the sub instruction table. The instruction of "END of sub instruction mode" must be set after these sub instruction sets. The **NJU6679** may occur incorrect operation if any main instructions on the main instruction table are input in mode of sub instruction table.

A0	\overline{RD}	\overline{WR}	D7	D6	D5	D4	D3	D2	D1	D0
0	1	0	0	1	1	1	0	0	0	1

(o) Bias Select

This instruction sets the bias voltage.

A0	\overline{RD}	\overline{WR}	D7	D6	D5	D4	D3	D2	D1	D0	
0	1	0	1	0	1	1	A3	A2	A1	A0	(*:Don't Care)

A3	A2	A1	A0	Bias
0	0	0	0	1/4
0	0	0	1	1/5
0	0	1	0	1/6
0	0	1	1	1/7
0	1	0	0	1/8
0	1	0	1	1/9
0	1	1	0	1/10
0	1	1	1	1/11
1	*	*	*	1/12

(p) Boost Level Select

This instruction sets the boost level (2 to 6 times). When "Partial Display Instruction" execution, the "Boost Level Select" also must be executed. If the external capacitors are connected as the lower than 6 times boost level, don't set the boost level by the instruction over than the boost level by connecting capacitors. If set the boost level over than it, the device will make malfunction.

A0	\overline{RD}	\overline{WR}	D7	D6	D5	D4	D3	D2	D1	D0
0	1	0	0	0	1	1	0	A2	A1	A0

Command			Booster Multiple				
A2	A1	A0	6times external capacitors connections	5times external capacitors connections	4times external capacitors connections	3times external capacitors connections	2times external capacitors connections
0	0	0	2-time				
0	0	1	3-time	2-time			
0	1	0	4-time	3-time	2-time		
0	1	1	5-time	4-time	3-time	2-time	
1	*	*	6-time	5-time	4-time	3-time	2-time

(q) Read Modify Write/End

This instruction sets the Read Modify Write controlling the page address increment. In this mode, the Column Address only increments when execute the display data "Write" instruction; but no change when the display data "Read" Instruction. This status is continued until the End instruction execution. When the End instruction is executed, the Column Address goes back to the start address before the execution of this "Read Modify Write" instruction. This function reduces the load of MPU for repeating display data change of the fixed area (ex. cursor blink).

A0	\overline{RD}	\overline{WR}	D7	D6	D5	D4	D3	D2	D1	D0
0	1	0	1	1	1	0	0	0	0	D

D 0 : Read Modify Write On

1 : End

Note) In this "Read Modify Write" mode, out of display data "Read"/"Write", any instructions except "Column Address Set" can be executed.

- The Example of Read Modify Write Sequence

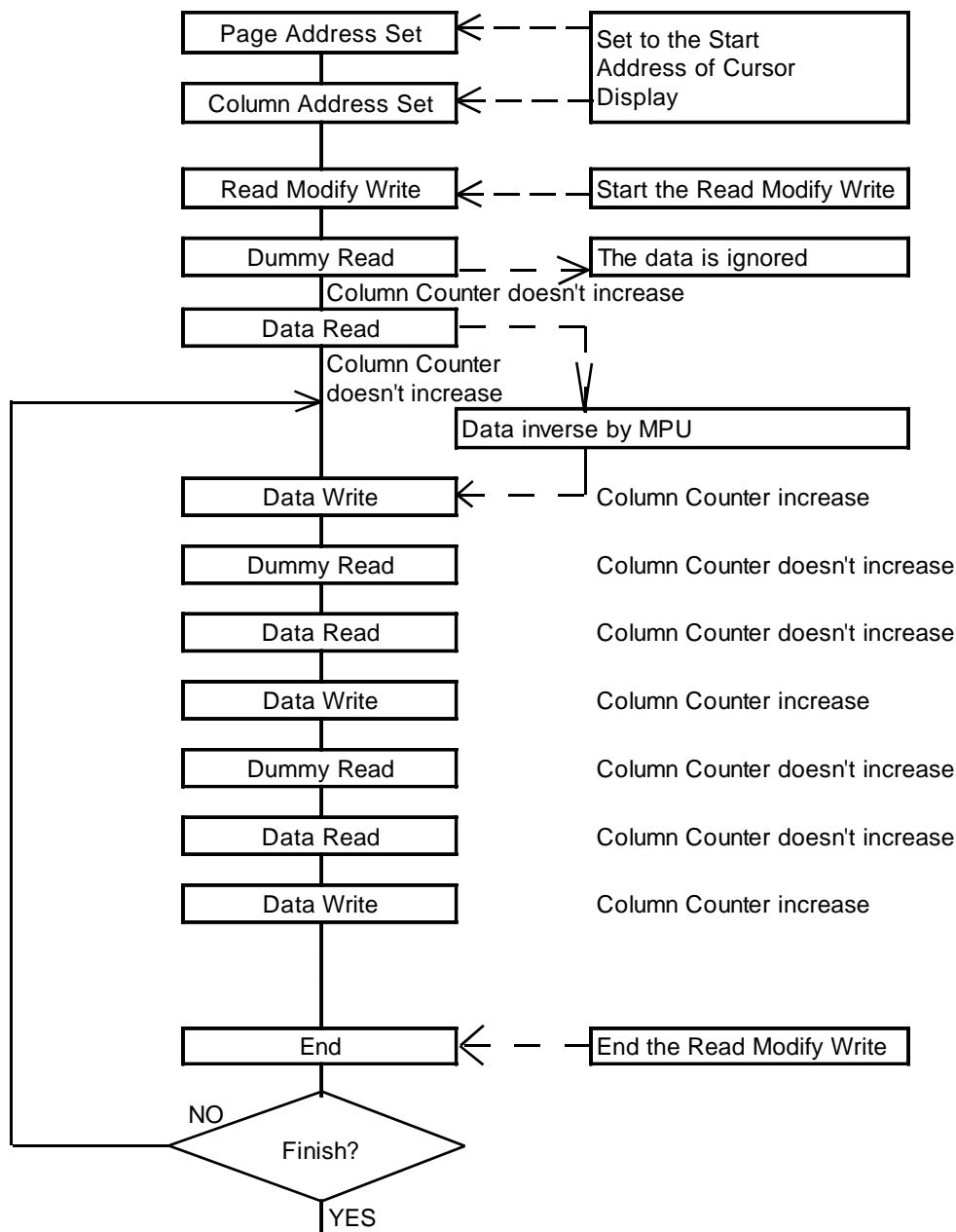

(r) Reset

This instruction executes the following initialization.

The reset by the reset signal input to the \overline{RES} terminal (hardware reset) is required when power turns on. This reset instruction does not use instead of this hardware reset when power turns on.

Initialization

- 1 Set the Column Address Counter to 00H
- 2 Set the Display Start Line Register to 00H
- 3 Set the Page Address Register to page "0"
- 4 Set the EVR register to FFH
- 5 Set the Partial Display(1/128 duty)
- 6 Set the Bias select(1/12 Bias)
- 7 Set the Voltage Booster(6 times)
- 8 Set the n-line inverse register to 0H

The DD RAM is not affected by this initialization.

A0	\overline{RD}	\overline{WR}	D7	D6	D5	D4	D3	D2	D1	D0
0	1	0	1	1	1	0	0	0	1	0

(s) Internal Power Supply ON/OFF

This instruction control ON and OFF for the internal Voltage Converter, Voltage Regulator and Voltage Follower circuits. For the Booster circuits operation, the oscillation circuits must be in operation.

A0	\overline{RD}	\overline{WR}	D7	D6	D5	D4	D3	D2	D1	D0
0	1	0	0	0	1	0	0	0	0	D

D 0 : Internal Power Supply Off

1 : Internal Power Supply On

The internal Power Supply must be Off when external power supply using.

*1 The set up period of internal power supply On depends on the step up capacitors, voltage stabilizer capacitors, VDD and VLCD.

Therefore it requires the actual evaluation using the LCD module to get the correct time. (Refer to the (3-4) Fig.5)

(t) Driver Outputs ON/OFF

This instruction controls ON/OFF of the LCD Driver Outputs.

A0	\overline{RD}	\overline{WR}	D7	D6	D5	D4	D3	D2	D1	D0
0	1	0	0	0	1	0	0	0	1	D

D 0 : LCD driving waveform output Off

1 : LCD driving waveform output On

The **NJU6679** implements low power LCD driving voltage generator circuit and requires the following Power Supply ON/OFF sequence.

- LCD Driving Power Supply ON/OFF Sequences

The sequences below are required when the power supply turns ON/OFF.

For the power supply turning on operation after the power-save mode, refer the "power save release sequence" mentioned after.

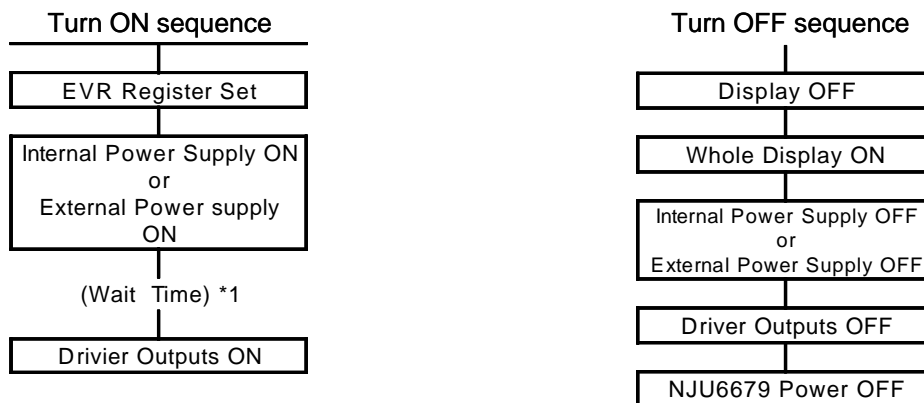

*1 The Internal Power Supply rise time is depending on the condition of the Supply Voltage, VLCD=VDD-V5, External Capacitor of Booster, and External Capacitor connected to V1 to V5. To know the rise time correctly, test by using the actual LCD module.

(u) Power Save (complex comand)

When Static Drive ON at the Display OFF status (inverse order also same), the internal circuits goes to the Power Save Mode and the operating current is dramatically reduced, almost same as the standby current. The internal status in the Power Save Mode is shown as follows;

- 1: The Oscillation Circuits and the Internal Power Supply Circuits stop the operation.
- 2: LCD driving is stopped. Segment and Common drivers output V_{DD} level voltage.
- 3: The display data and the internal operating condition are remained and kept as just before enter the Power Save Mode.
- 4: All the LCD driving bias voltage (V_1 to V_5) is fixed to the V_{DD} level.

The power save and its release perform according to the following sequences.

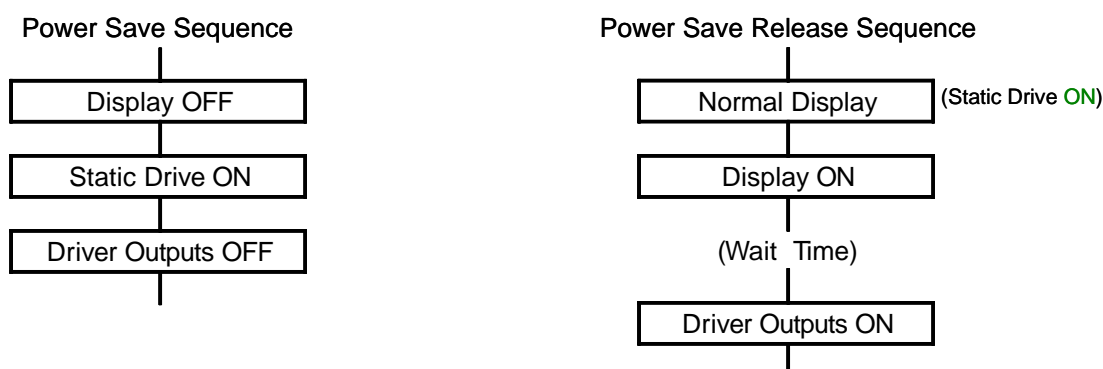

The **NJU6679** constantly spends the current without the execution of the Driver Outputs OFF instruction. The LCD drive waveform is not output until the Driver Outputs ON instruction is executed.

- *1 In the Power Save sequence, the Power Save Mode starts after the Static Drive ON command is executed.
- *2 In the Power Save Release sequence, the Power Save Mode releases just after the Static Drive OFF instruction execution. The Display ON instruction is allowed to execute at any time after the Static Drive OFF instruction is completed.
- *3 The Internal Power Supply rise time is depending on the condition of the Supply Voltage, $V_{LCD}=V_{DD}-V_5$, External Capacitor of Booster, and External Capacitor connected to V_1 to V_5 . To know the rise time correctly, test by using the actual LCD module.
- *4 LCD driving waveform is output after the execution of the Driver Outputs ON instruction execution.
- *5 In case of the external power supply operation, the external power supply should be turned off before the Power Save Mode and connected to the V_{DD} for fixing the voltage. In this time, V_{OUT} terminal also should be made condition like as disconnection or connection to V_{SS} .

(v) ADC Select

This instruction determines the correspondence of Column in the DD RAM with the Segment Driver Outputs. Segment Driver Output order is inverted when this instruction executes, therefore, the placement the **NJU6679** against the LCD panel becomes easy.

A0	\overline{RD}	R/W \overline{WR}	D7	D6	D5	D4	D3	D2	D1	D0
0	1	0	1	0	1	0	0	0	0	D

D 0 : Clockwise Output (Normal) Segment Driver S_0 to S_{131}
 1 : Counterclockwise Output (Inverse) Segment Driver S_{131} to S_0

(3) Internal Power Supply

(3-1) 6-time voltage booster circuits

The 6-time voltage booster circuit outputs the negative Voltage (V_{DD} Common) boosted 6 times of $V_{DD}-V_{SS}$ from the V_{OUT} terminal with connecting the six capacitors between C_{1+} and C_{1-} , C_{2+} and C_{2-} , C_{3+} and C_{3-} , C_{4+} and C_{4-} , C_{5+} and C_{5-} , and V_{SS} and V_{OUT} . The boosting time is selected out of 2 times to 6 by the combination of changing the external capacitors connection and "Booster Level Select" instruction. (refer (2-1) Instruction (p) Voltage Boost time select) Voltage Booster circuits requires the clock signals from internal oscillation circuit or the external clock signal, therefore, the internal oscillation circuits or the external clock supplier must be operating when the voltage booster is in operation.

The boosted voltage of $V_{DD}-V_{OUT}$ must be 18V or less.

The boost voltage and the capacitor connection are shown below.

● The boosted voltage and V_{DD}, V_{SS}

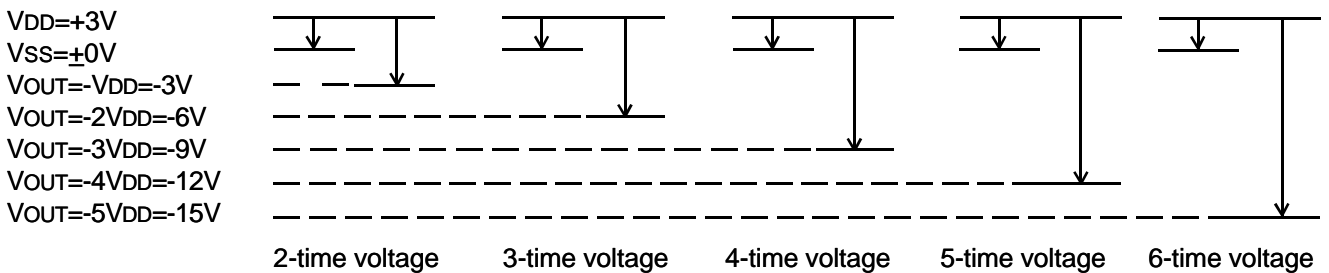

● Example of the external capacitor connection to the voltage booster circuits

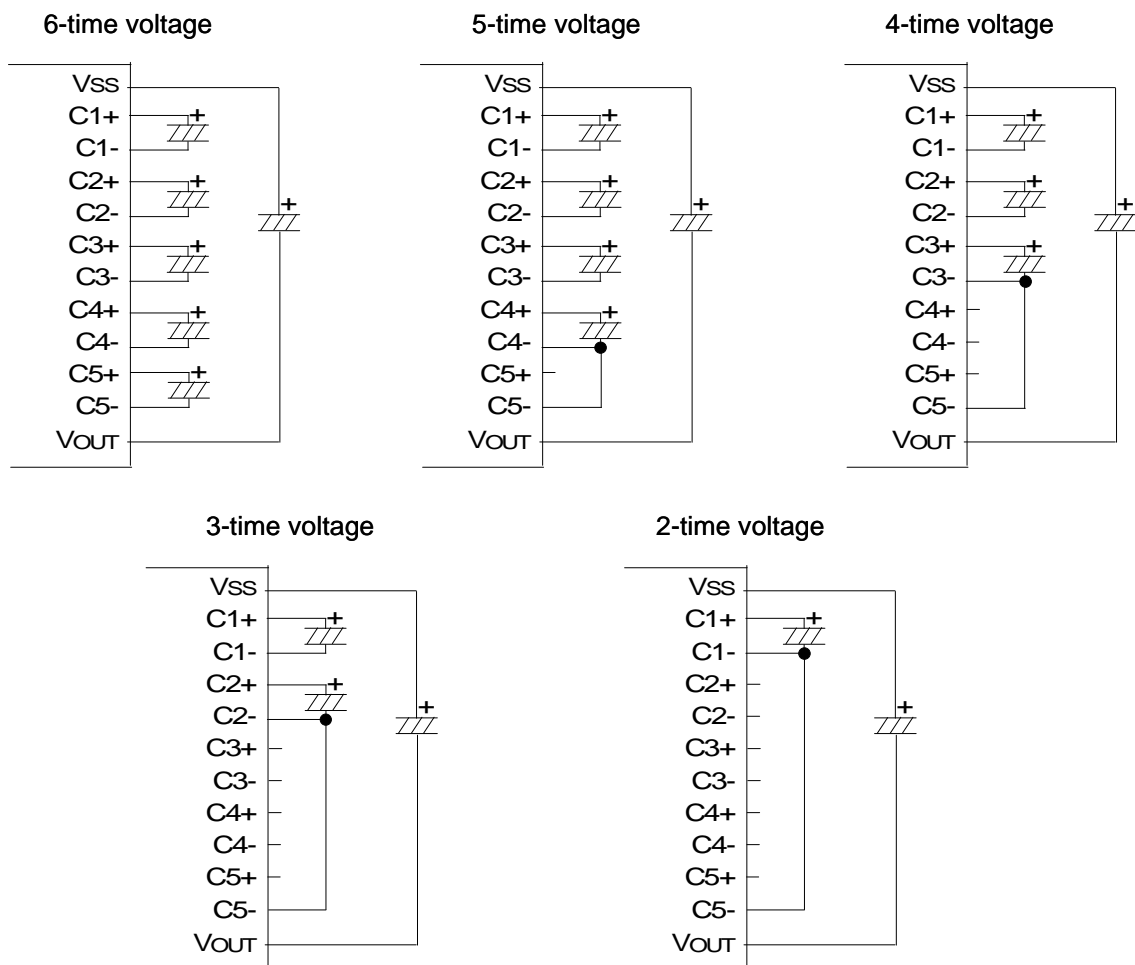

(3-2) Voltage Adjust Circuits

The boosted voltage of V_{OUT} outputs V_5 for LCD driving through the voltage adjust circuits. The output voltage of V_5 is adjusted by R_a and R_b within the range of $|V_5| < |V_{OUT}|$.

The output is calculated by the following formula(1).

$$V_{LCD} = V_{DD} - V_5 = (1 + R_b/R_a)V_{REG} \quad (1)$$

The V_{REG} voltage is a reference voltage generated by the built-in bleeder resistance. V_{REG} is adjustable by EVR functions (see section 3-3).

For minor adjustment of V_5 , it is recommended that the R_a and R_b is composed of R_2 as variable resistor and R_1 and R_3 as fixed resistors, constant should be connected to V_{DD} terminal, V_R and V_5 , as shown below.

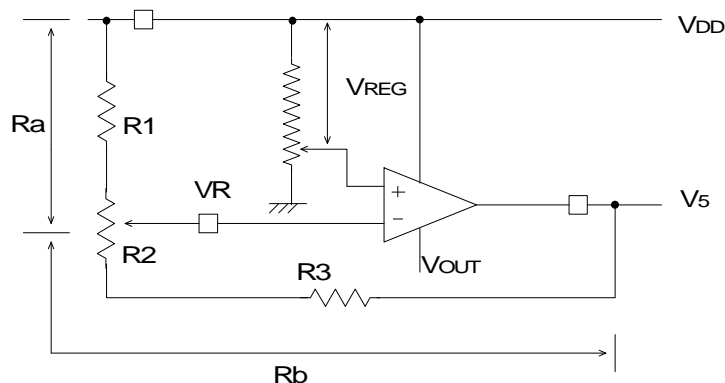

Fig. 4

< Design example for R_1 , R_2 and R_3 /Reference >

- $R_1 + R_2 + R_3 = 6M\Omega$
(Determind by the current between $V_{DD} - V_5$)
- Variable voltage range by the R_2 . -7V to -11V ($V_{LCD} = V_{DD} - V_5$: 10V to 12V)
(Determind by the LCD electrical characteristics)
- $V_{REG} = 3V$
(In case of $V_{DD} = 3V$ and $EVR = FFh$)

R_1, R_2 and R_3 are calculated by above conditions and the fomula of (1) to below;

$$\begin{aligned} R_1 &= 1.5M\Omega \\ R_2 &= 0.3M\Omega \\ R_3 &= 4.2M\Omega \end{aligned}$$

Note) V_5 voltage is generated referencing with V_{REG} voltage beased on the supply voltage (V_{DD} and V_{SS}) as shown in above figure. Therefore, V_{LCD} ($V_{DD} - V_5$) is affected including the gain (R_b/R_a) by the fluctuation of V_{REG} voltage based on the supply voltage. The power supply voltage should be stabilized for V_5 stable operation.

(3-3) Contrast Adjustment by the EVR function

The EVR selects the V_{REG} voltage out of the following 201 conditions by setting 8-bit data into the EVR register. With the EVR function, V_{REG} is controlled, and the LCD display contrast is adjusted. The EVR controls the voltage of V_{REG} by instruction and changes the voltage of V_5 .

A step with EVR is set like table shown below.

37H to 4FH available for use. If keeping 3% precision, sets EVR over 4FH.

EVR register		$V_{REG}[V]$	VLCD
3FH	(0,0,1,1,0,1,1,1)	$(100/300) \times (V_{DD}-V_{SS})$	Low
:	:	:	:
4FH	(0,1,0,0,1,1,1,1)	$(124/300) \times (V_{DD}-V_{SS})$:
:	:	:	:
:	:	:	:
FDH	(1,1,1,1,1,1,0,1)	$(298/300) \times (V_{DD}-V_{SS})$:
FEH	(1,1,1,1,1,1,1,0)	$(299/300) \times (V_{DD}-V_{SS})$:
FFH	(1,1,1,1,1,1,1,1)	$(300/300) \times (V_{DD}-V_{SS})$	High

In use of the EVR function, the voltage adjustment circuit must turn on by the power supply instruction.

● Adjustable range of the LCD driving voltage by EVR function

The adjustable range is decided by the power supply voltage V_{DD} and the ratio of external resistors R_a and R_b .

[Design example for the adjustable range / Reference]

- Condition $V_{DD}=3.0V$, $V_{SS}=0V$

$R_a=1M\Omega$, $R_b=4M\Omega$ ($R_a:R_b=1:4$)

The adjustable range and the step voltage are calculated as follows in the above condition.

In case of setting 4FH in the EVR register,

$$\begin{aligned} V_{LCD} &= ((R_a+R_b)/R_a)V_{REG} \\ &= (5/1) \times [(124/300) \times 3.0] \\ &= 6.2V \end{aligned}$$

In case of setting FFH in the EVR register,

$$\begin{aligned} V_{LCD} &= ((R_a+R_b)/R_a)V_{REG} \\ &= (5/1) \times [(300/300) \times 3.0] \\ &= 15.0V \end{aligned}$$

	Min.4FH	Max.FFH
Adjustable Range	6.2	15.0 [V]
Step Voltage	50 [mV]	

* In case of $V_{DD}=3V$

(3-4) LCD Driving Voltage Generation Circuits

The LCD driving bias voltage of V1,V2,V3,V4 are generated by dividing the V5 voltage with the internal bleeder resistance and is supplied to the LCD driving circuits after the impedance conversion by the voltage follower.

As shown in Figure 5, five external capacitors are required to connect to each LCD driving voltage terminal for voltage stabilization. The value of capacitors (C6 to C10) should be determined after the actual LCD panel display evaluation.

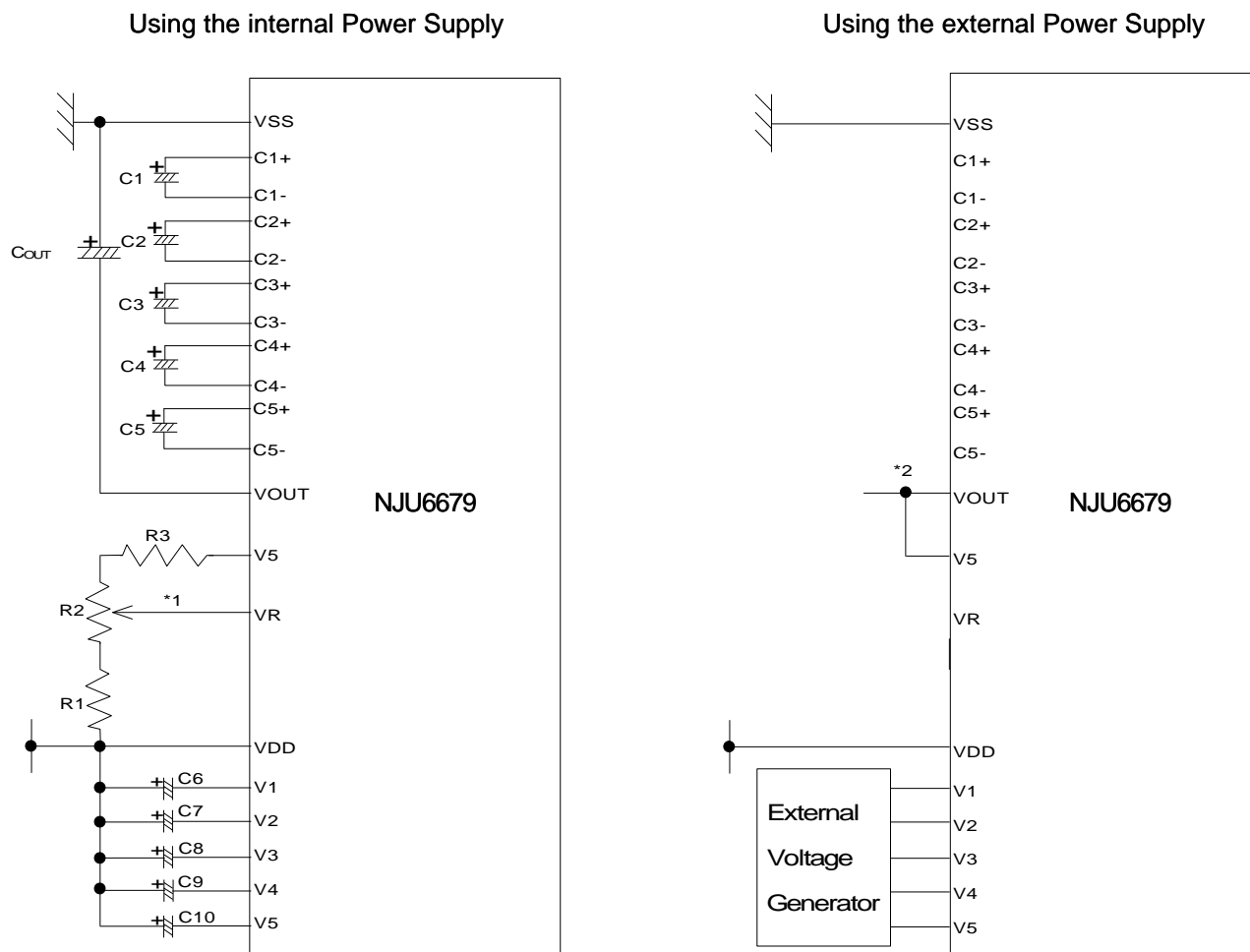

Reference set up value $V_{LCD} = V_{DD} - V5 = 10$ to $12V$

C _{OUT}	to 1 μ F
C1 to C4, C9	to 1 μ F
C5 to C8	0.1 to 0.47 μ F
R1	1.5M Ω
R2	0.3M Ω
R3	4.2M Ω

Fig.5

*1 Short wiring or sealed wiring to the VR terminal is required due to the high impedance of VR terminal.

*2 Following connection of VOUT is required when external power supply using.

When $V_{SS} > V5$ --- $V_{OUT} = V5$

When $V_{SS} \leq V5$ --- $V_{OUT} = V_{SS}$

(4) MPU Interface

(4-1) Interface type selection

Two MPU interface types are available in the **NJU6679**: by 1) 8-bit bi-directional data bus (D7 to D0), 2) serial data input (SI:D7). The interface type (the 8 bit parallel or serial interface) is determined by the condition of the P/S terminals connecting to "H" or "L" level as shown in Table 5. In case of the serial interface, neither the status read-out nor the RAM data read-out operation is allowed.

Table 5

P/S	Type	\overline{CS}	A0	\overline{RD}	\overline{WR}	SEL68	D7	D6	D0 to D5
H	Parallel	\overline{CS}	A0	\overline{RD}	\overline{WR}	SEL68	D7	D6	D0 to D5
L	Serial	\overline{CS}	A0	-	-	-	SI	SCL	Hi-Z

Parallel Interface

The **NJU6679** interfaces the 68- or 80-type MPU directly if the parallel interface (P/S="H") is selected. The 68-type or 80-type MPU is selected by connecting the SEL68 terminal to "H" or "L" as shown in table 6.

Table 6

SEL68	Type	\overline{CS}	A0	\overline{RD}	\overline{WR}	D0 to D7
H	68 type MPU	\overline{CS}	A0	E	R/W	D0 to D7
L	80 type MPU	\overline{CS}	A0	\overline{RD}	\overline{WR}	D0 to D7

(4-2) Discrimination of Data Bus Signal

The **NJU6679** discriminates the mean of signal on the data bus by the combination of A0, E, R/W, and (\overline{RD} , \overline{WR}) signals as shown in Table 7.

Table 7

Common	68 type		80 type		Function
	A0	R/W	\overline{RD}	\overline{WR}	
H	H	H	L	H	Read Display Data
H	L	L	H	L	Write Display Data
L	H	H	L	H	Status Read
L	L	L	H	L	Write into the Register(Instruction)

(4-3) Serial Interface.(P/S="L")

The serial interface of the **NJU6679** consists of the 8-bit shift register and 3-bit counter. In case the chip is selected (\overline{CS} =L), the input to D7(SI) and D6(SCL) becomes available, and in case that the chip isn't selected, the shift register and the counter are reset to the initial condition.

The data input from the terminal(SI) is MSB first like as the order of D7, D6, ●●●D0 by a serial interface, it is entered into with rise edge of serial clock(SCL). The data converted into parallel data of 8-bit with the rise edge of 8th serial clock and processed.

It discriminates display data or instructions by A0 input terminal. A0 is read with rise edge of (8 X n)th of serial clock (SCL), it is recognized display data by A0="H" and instruction by A0="L". A0 input is read in the rise edge of (8 X n)th of serial clock (SCL) after chip select and distinguished.

However, in case of RES="H" to "L" or \overline{CS} ="L" to "H" with trasfered data does not fill 8 bit, attention is necessary because it will processed as there was command input. Always, input the data of (8 X n) style.

The SCL signal must be careful of the termination reflection by the wiring length and the external noise and confirmation by the actual machine is recommended by it.

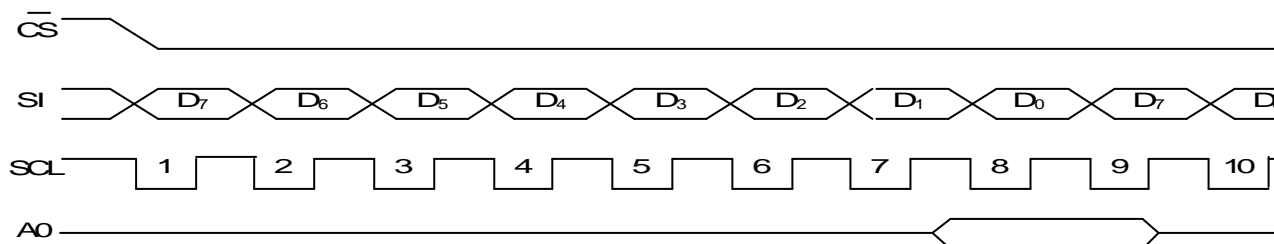

Fig. 6

(4-4) Access to the Display Data RAM and Internal Register.

The **NJU6679** transfers data to the CPU through the bus holder with the internal data bus.

In case of reading out the display data contents in the DD RAM, the data which was read in the first data read cycle (= the dummy read) is memorized in the bus holder. Then the data is read out to the system bus from the bus holder in the next data read cycle. Also, In case that the MPU writes into DD RAM, the data is temporarily stored in the bus holder and is then written into DD RAM by the next data write cycle.

Therefore, the limitation of the access to **NJU6679** from MPU side is not access time (t_{ACC}, t_{DS}) of Display Data RAM and the cycle time becomes dominant. With this, speed-up of the data transfer with the MPU becomes possible. In case of cycle time isn't met, the MPU inserts NOP operation only and becomes an equivalent to an execution of wait operation on the satisfy condition in MPU.

When setting an address, the data of the specified address isn't output immediately by the read operation after setting an address, and the data of the specified address is output at the the 2nd data read operation. Therefore, the dummy read is always necessary once after the address set and the write cycle. (See Fig. 7)

The exsample of Read Modify Write operaion is mentioned in (2-1)Instruction -(q)The sequence of Inverse Display.

● Write Operation

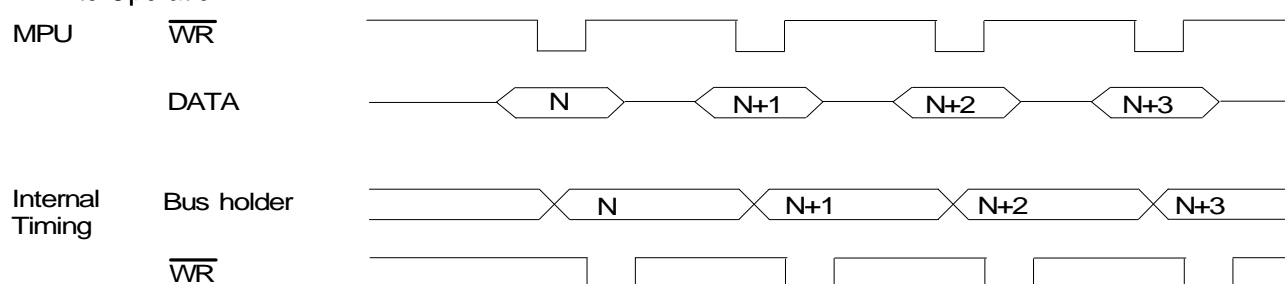

● Read Operation

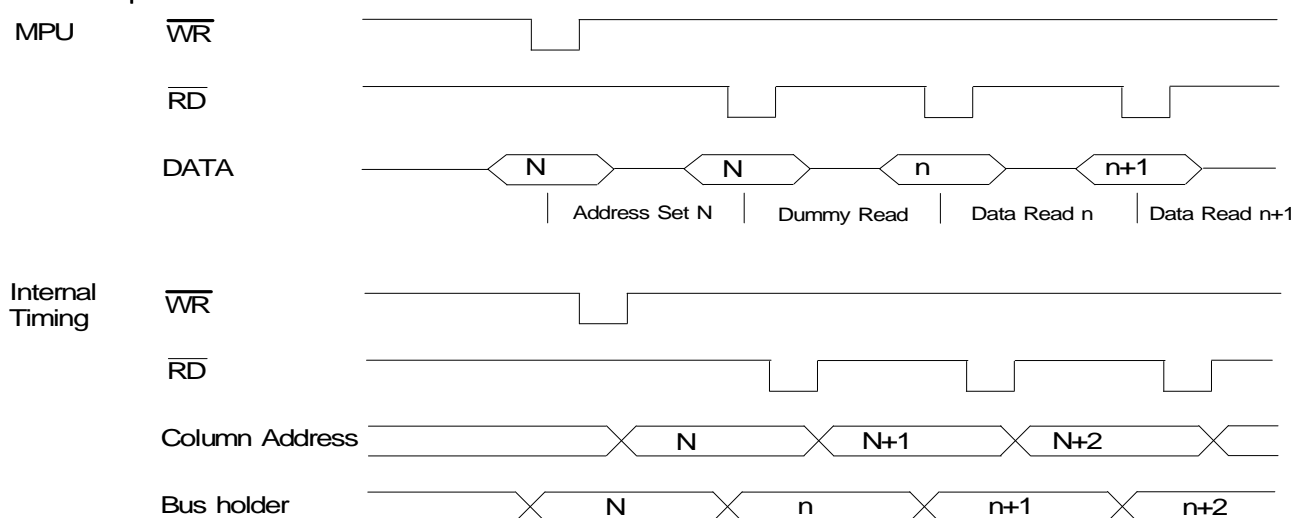

Fig.7

(4-6) Chip Select

\overline{CS} is the Chip Select terminal. In case of $\overline{CS}="L"$, the interface with MPU is available.

In case of $\overline{CS}="H"$ (Chip is not selected), the terminals of D_0 to D_7 are high impedance and A_0 , \overline{RD} , \overline{WR} , $D_7(SI)$ and $D_6(SCL)$ inputs are ignored. If the serial interface is selected when $\overline{CS}="H"$, the shift register and the counter for the serial interface are reset.

However, the reset signal is always input and executed in any conditions of \overline{CS} .

■ ABSOLUTE MAXIMUM RATINGS

(Ta=25°C)

PARAMETER	SYMBOL	RATINGS	UNIT
Supply Voltage (1)	V _{DD}	-0.3 to +5.0	V
Supply Voltage (2)	V ₅	V _{DD} -18.0 to V _{DD} +0.3	V
Supply Voltage (3)	V ₁ to V ₄	V ₅ to V _{DD} +0.3	V
Input Voltage	V _{IN}	-0.3 to V _{DD} +0.3	V
Operating Temperature	T _{opr}	-30 to +80	°C
Storage Temperature	T _{stg}	-55 to +125 (Chip)	°C
		-55 to +100 (TCP)	

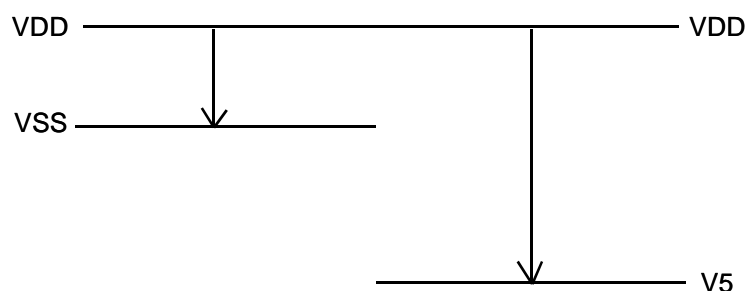

Note 1) All voltage values are specified as V_{SS}=0V.

Note 2) The relation of V_{DD} ≥ V₁ ≥ V₂ ≥ V₃ ≥ V₄ ≥ V₅ > V_{OUT}; V_{DD} > V_{SS} ≥ V_{OUT} must be maintained.

In case of inputting external LCD driving voltage, the LCD drive voltage should start supplying to **NJU6679** at the mean time of turning on V_{DD} power supply or after turned on V_{DD}.

In use of the voltage boost circuit, the condition that the supply voltage: 18.0V ≥ V_{DD} - V_{OUT} is necessary.

Note 3) If the LSI are used on condition beyond the absolute maximum rating, the LSI may be destroyed.

Using LSI within electrical characteristics is strongly recommended for normal operation.

Use beyond the electric characteristics conditions will cause malfunction and poor reliability.

Note 4) Decoupling capacitor should be connected between V_{DD} and V_{SS} due to the stabilized operation for the voltage converter.

■ ELECTRICAL CHARACTERISTICS (1)

(VDD=2.7V to 3.3V, VSS=0V, Ta=-30 to +80°C)

P A R A M E T E R		SYMBOL	C O N D I T I O N S		MIN.	TYP.	MAX.	UNIT	Note
Operating Voltage(1)		VDD			2.4		3.6	V	5
Operating Voltage(2)		V5			VDD-18.0		VDD-6.0	V	6
		V1,V2	VLCD= VDD-V5		VDD-0.5VLCD		VDD		
		V3,V4			V5		VDD-0.5VLCD		
Input Voltage	High Level	VIHC1	D0...D7,A0, CS,RES,RD,WR,SEL68, P/S Terminals		0.8VDD		VDD	V	
	Low Level	VILC1			VSS		0.2VDD	V	
Output Voltage	High Level	VOHC11	D0...D7 Terminals	IOH=-0.5mA	0.8VDD		VDD	V	
	Low Level	VOLC11			VSS		0.2VDD	V	
Input Leakage Current		IIIO	All Input terminals		- 1.0		1.0	uA	
Driver On-resistance		RON1	Ta=25°C	VLCD=15.0V		2.0	3.0	kΩ	7
		RON2		VLCD=8.0V		3.0	4.5		
Stand-by Current		IDDQ	during Power save Mode			0.05	5	uA	8
Operating Current		IDD12	Display VLCD=15.0V			40	80	uA	
		IDD21	Accessing f CYC=200kHz			650	850		
Input Terminal Capacitance		CIN	A0,CS,RES,RD,WR,SEL68, P/S,T1,T2,D0...D7 Ta=25°C			10		pF	10
Oscillation Frequency		fOSC	Ta=25°C		31.7	39	46.3	kHz	

Reset time	tR	RES Terminal	1.0			us	11
Reset "L" Level Pulse Width	trW	RES Terminal	10			us	12

Voltage Booster	Output Volt.	VOUT1	VSS-Vout, 6-time voltage booster, VDD=3V	VDD-15.0V		VDD-14.5V	V		
	On-resistance	RTRI	VDD=3V;COUT=4.7uF 6-time voltage booster		2000	4000	Ω		
	Adjustment range of LCD Driving Volt.	VOUT2	Voltage Booster Circuit "OFF"	VDD-18.0V		VDD-6.0V	V	13	
	Voltage Follower	V5	Voltage Adjustment Circuit "OFF"	VDD-18.0V		VDD-6.0V	V		
	Operating Current	IOUT1	IOUT2	VDD=3V, VLCD=12V		250	450	uA	14
				COM/SEG Terminals Open		45	90		
No Access									
Voltage Reg.	VREG%	VREG	VDD=3V,Ta=25°C, VREG=4F to FFH			3	%		

Note 5) Although the **NJU6679** can operate in wide range of the operating voltage, it shall not be guaranteed in a sudden voltage fluctuation during the access with MPU.

Note 6) The operating voltage when using external power supply.

Note 7) RON is the resistance values in supplying 0.1V voltage-difference between power supply terminals (V1,V2,V3,V4) and each output terminals (common/ segment). This is specified within the range of Operating Voltage(2).

Note 8,9) The value of after Driver Output On instruction execution.

Note 8,9) Refers to the current consumption of the IC itself; external power supply is used for the LCD driving. In case of not use internal power supply circuit,meaning current of IC's. LCD driving power supply are external power supply.

Note 8) Applicable in case of not accessing to the MPU.

Note 9) The operating current when writing a vertical stripe pattern on the tcyc. Current consumption during the access is approximately proportional to the access frequency. When not accessed, it consumes only IDD01

Note 10) Apply to A0, D0-D7, RD,WR,CS,RES,SEL68,P/S,T1,T2 terminals.

Note 11) t_R (Reset Time) refers to the reset completion time of the internal circuits from the rise edge of the \overline{RES} signal.

Note 12) Apply minimum pulse width of the \overline{RES} signal. To reset, the "L" pulse over t_{RW} shall be input. .

Note 13) The voltage adjustment circuit controls V5 within the range of the voltage follower operating voltage.

Note 14) Each operating current shall be defined as being measured in the following condition.

SYMBOL	Status		Operating Condition				External Voltage Supply (Input Terminal)
	T1	T2	Internal Oscillator	Voltage Booster	Voltage Adjustment	Voltage Follower	
IOUT1	L	L/H	Validity	Validity	Validity	Validity	Unuse
IOUT2	H	L	Validity	Invalidity	Validity	Validity	Use(VOUT)
IOUT3	H	H	Validity	Invalidity	Invalidity	Validity	Use(VOUT,V5)

MEASUREMENT BLOCK DIAGRAM

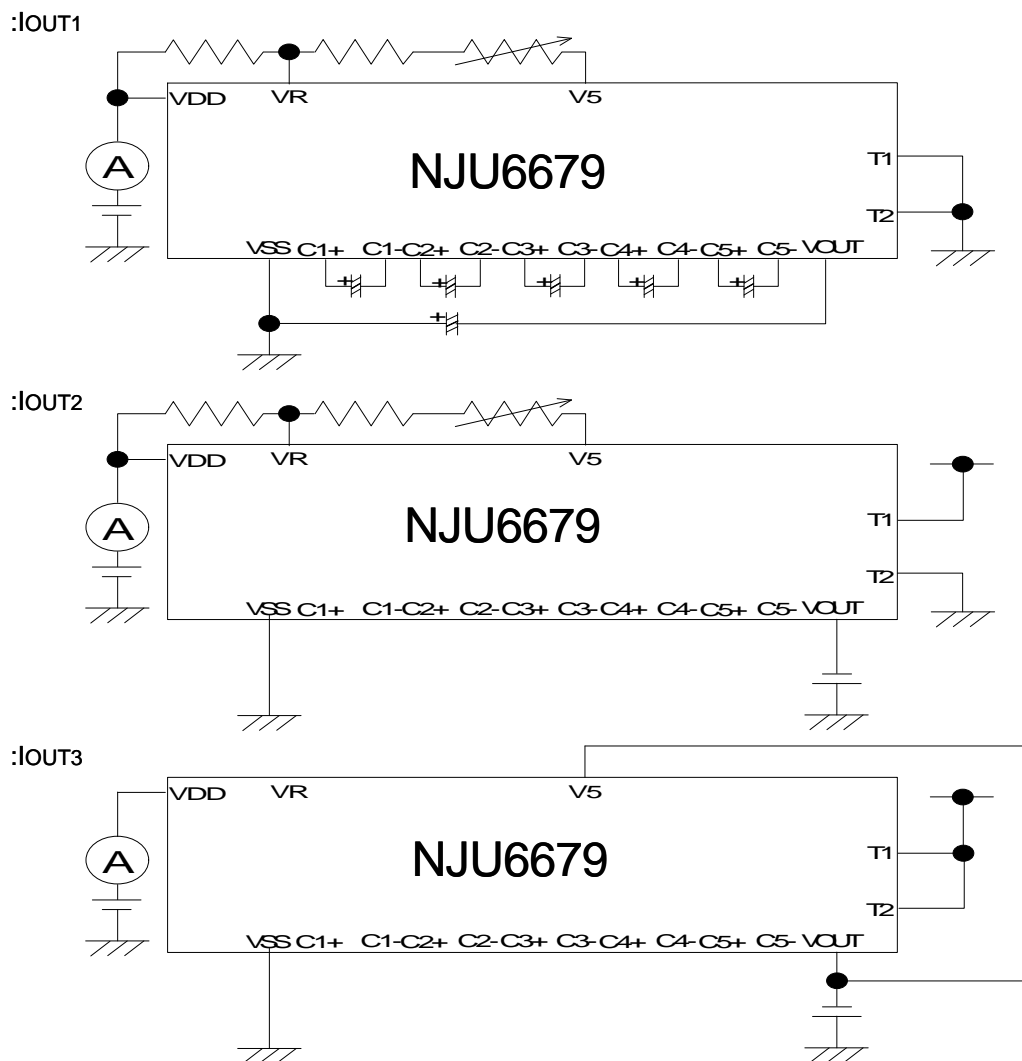

■ BUS TIMING CHARACTERISTICS

- Read/Write operation sequence (80 Type MPU)

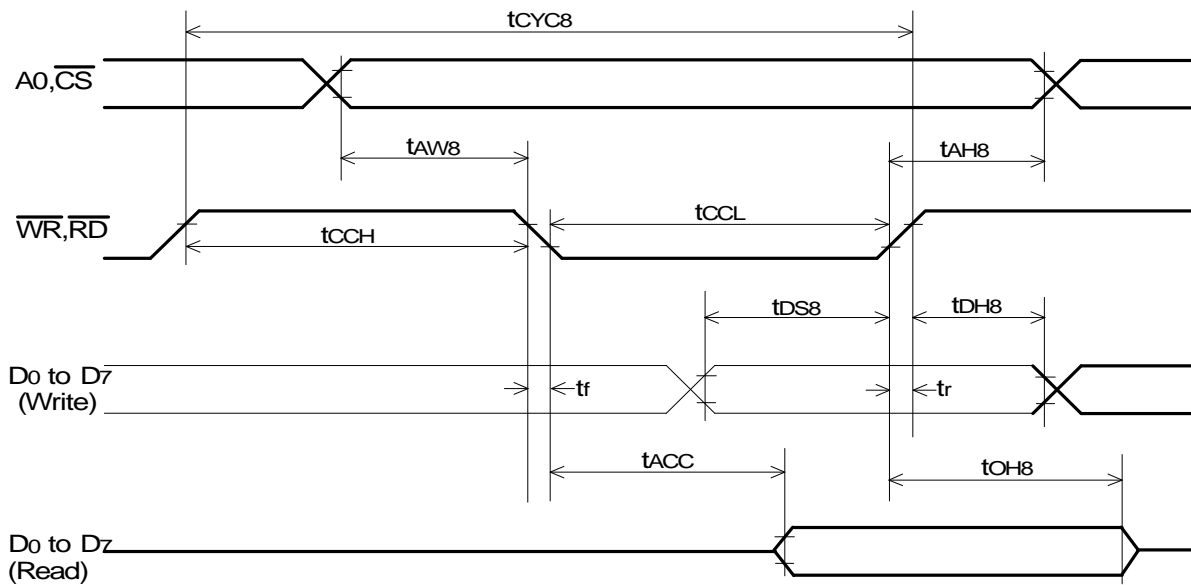

(VDD=2.4V to 3.6V, Ta=-30 to +80°C)

PARAMETER		SYMBOL	MIN.	TYP.	MAX.	CONDITION	UNIT
Address Hold Time	A0, \overline{CS}	tAH8	10				ns
Address Set Up Time	Terminals	tAW8	0				ns
System Cycle Time	WR	tCYC8 (W)	270	220			ns
	RD	tCYC8 (R)	350				ns
Control Pulse Width	WR, "L"	tCCL(W)	50				ns
	RD, "L"	tCCL(R)	200				ns
	WR, "H"	tCCH(W)	220	160			ns
	RD, "H"	tCCH(R)	150				ns
Data Set Up Time	D0 to D7 Terminals	tDS8	35				ns
Data Hold Time		tDH8	15				ns
RD Access Time		tACC8			120	CL=100pF	ns
Output Disable Time		tOH8	0		50		ns
Rise Time, Fall Time	\overline{CS} , WR, \overline{RD} , A0, D0 to D7 Terminals	tr, tf			15		ns

Note 15) All timing based on 20% and 80% of VDD voltage level.

- Read/Write operation sequence (68 Type MPU)

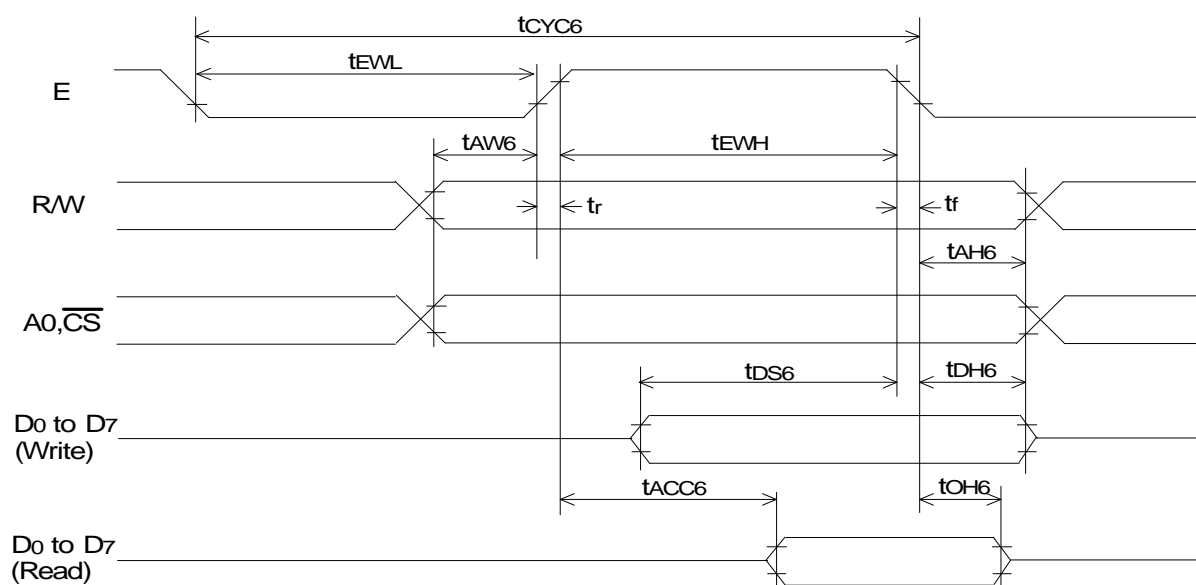

(VDD=2.4V to 3.6V, Ta=-30 to +80°C)

P A R A M E T E R		SYMBOL	MIN.	TYP.	MAX.	CONDITION	UNIT
Address Hold Time	A0, \overline{CS} , R/W Terminals	tAH6	10				ns
Address Set Up Time		tAW6	0				ns
System Cycle Time(W)		tCYC6(W)	270	220			ns
System Cycle Time(R)		tCYC6(R)	350				ns
Enable Pulse Width	E Terminal	tEWH	200				ns
			50				ns
		tEWL	220	160			ns
			150				ns
Data Set Up Time	D0 to D7 Terminals	tDS6	35				ns
Data Hold Time		tDH6	15				ns
Access Time		tACC6			200	CL=100pF	ns
Output Disable Time		tOH6	0		50		ns
Rise Time, Fall Time	A0, \overline{CS} , R/W, E, D0 to D7 Terminals	tr,tf			15		ns

Note 16) All timing are based on 20% and 80% of VDD voltage level.

Note 17) tCYC6 shows the cycle of the E signal in active \overline{CS} .

- Write operation sequence (Serial Interface)

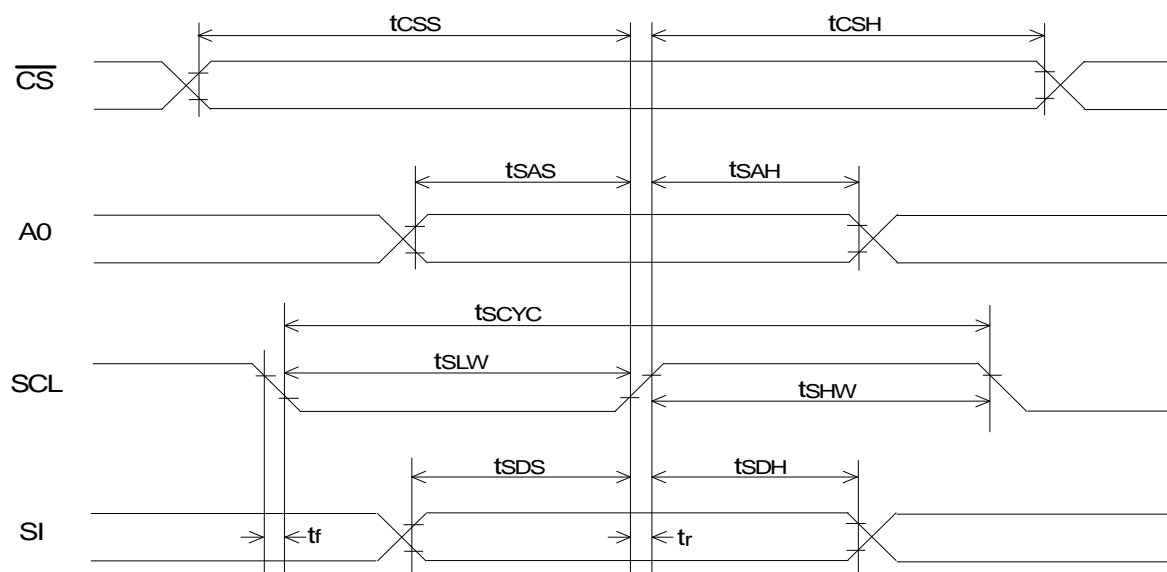

(VDD=2.4V to 3.6V, Ta=-30 to +80°C)

PARAMETER		SYMBOL	MIN.	TYP.	MAX.	CONDITION	UNIT
Serial Clock cycle	SCL Terminal	tSCYC	60				ns
SCL "H" pulse width		tSHW	30				ns
SCL "L" pulse width		tSLW	30				ns
Address Set Up Time	A0 Terminal	tSAS	25				ns
Address Hold Time		tSAH	150				ns
Data Set Up Time	SI Terminal	tSDS	25				ns
Data Hold Time		tSDH	10				ns
CS-SCL Time	CS Terminal	tCSS	10				ns
		tCSH	300				ns
Rise Time, Fall Time	SCL, A0, CS, SI Terminals	tr,tf			15		ns

Note 18) All timing are based on 20% and 80% of VDD voltage level.

Note 19) When inputting an instruction continuously, keep 450ns as the cycle of SCL between the instructions as follows

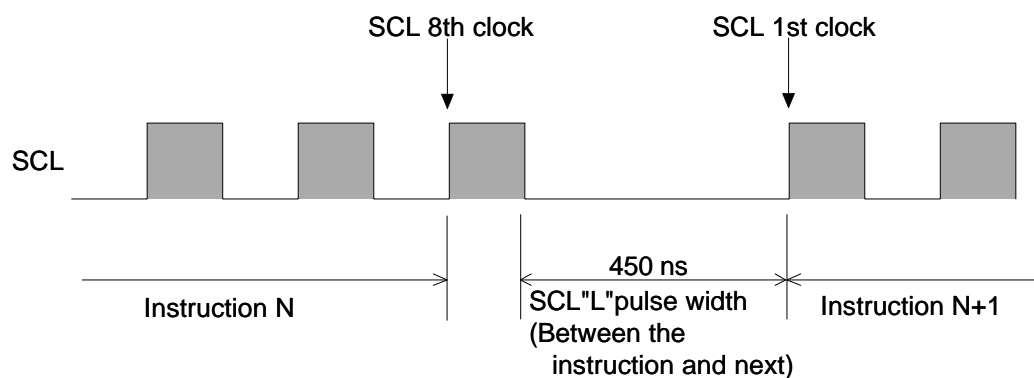

■ LCD DRIVING WAVEFORM

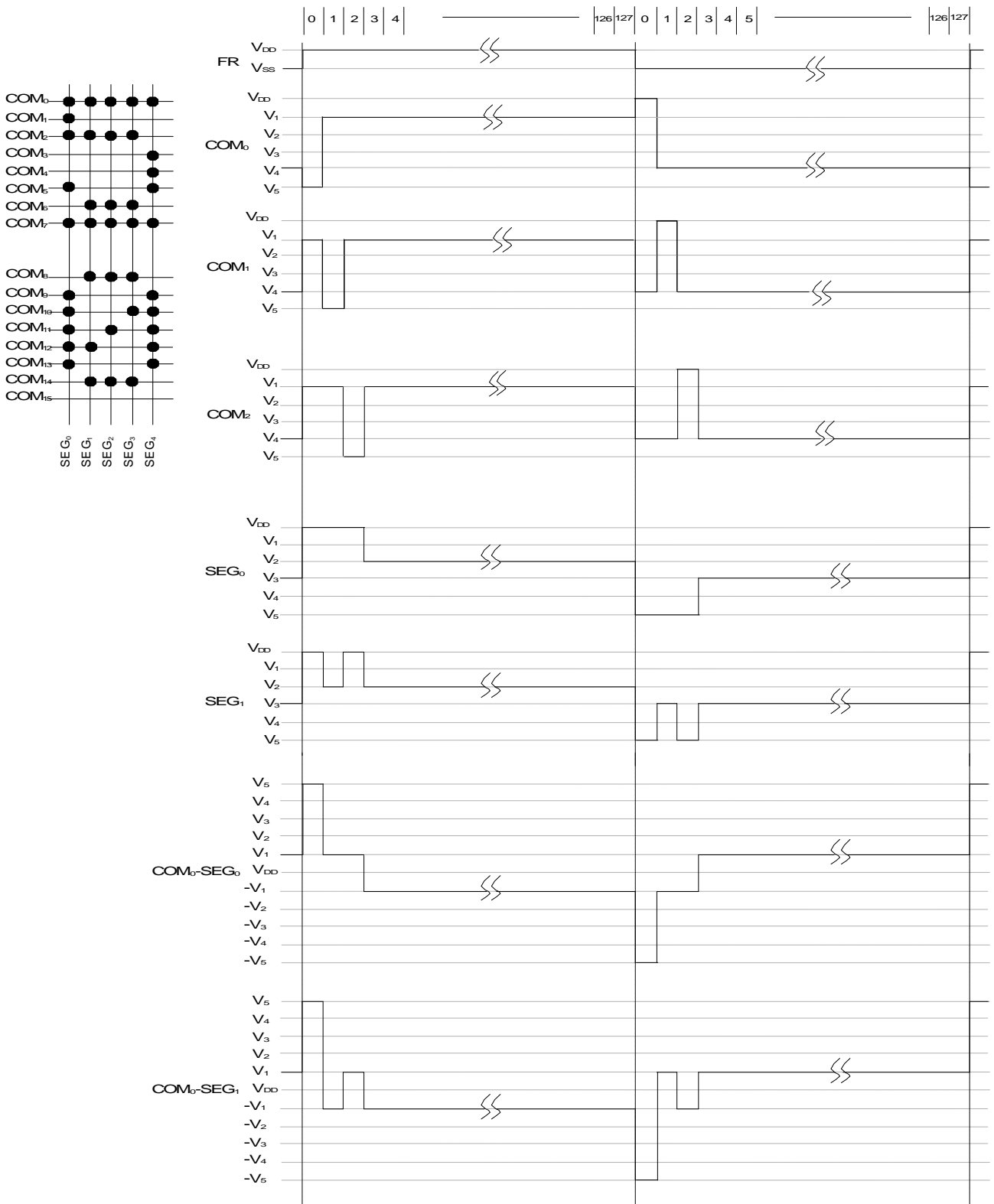

APPLICATION CIRCUIT

MPU Interface (examples)

The **NJU6679** is connectable to 80-type MPU or 68-type. In use of Serial Interface, it is possible to be controlled by the signal line with the more small being.

*:SEL68 terminal shall be connected to V_{DD} or V_{SS}.

- 80 Type MPU

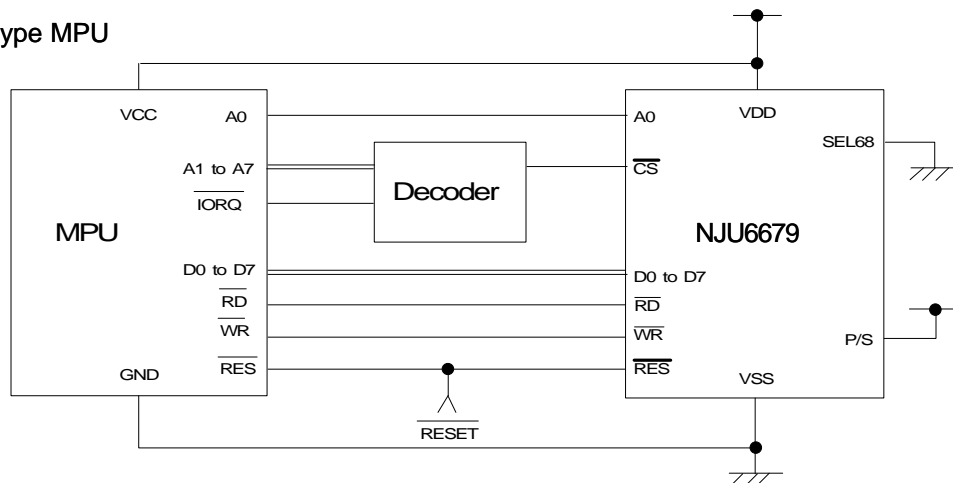

- 68 Type MPU

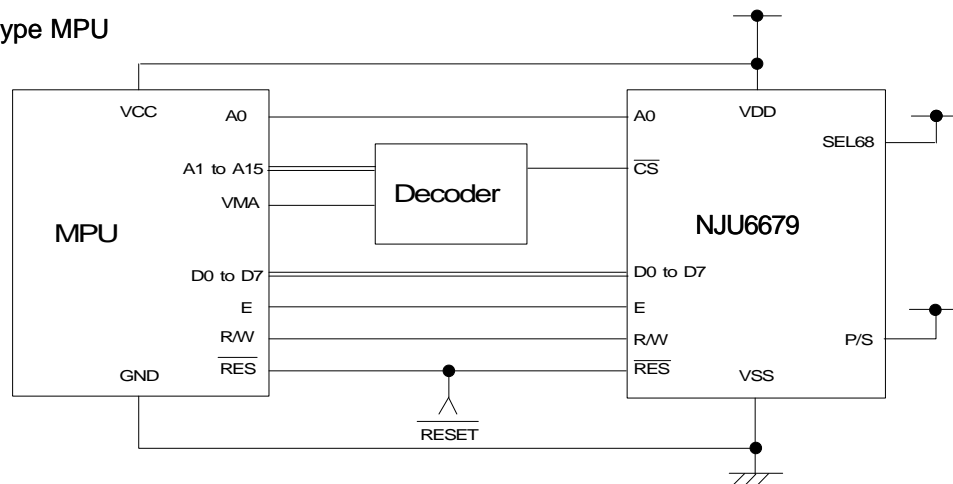

- Serial Interface

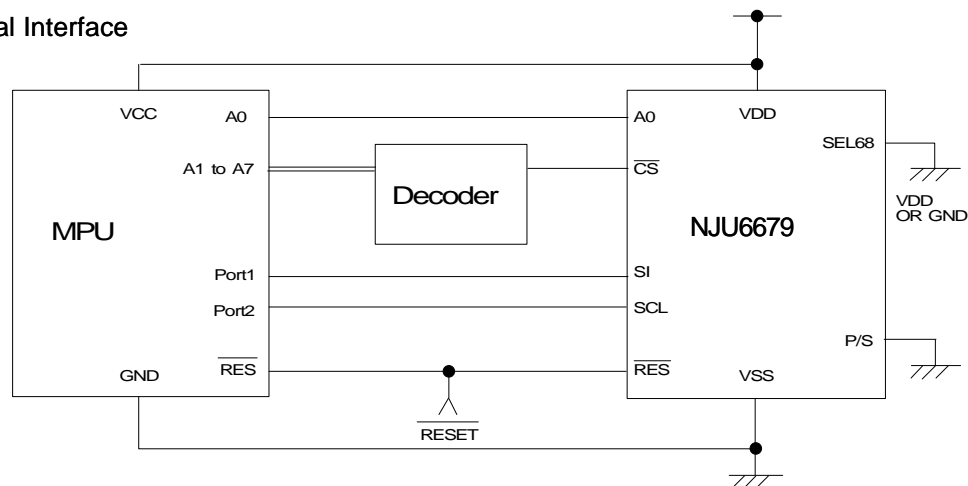

■ LCD Panel Interface Example

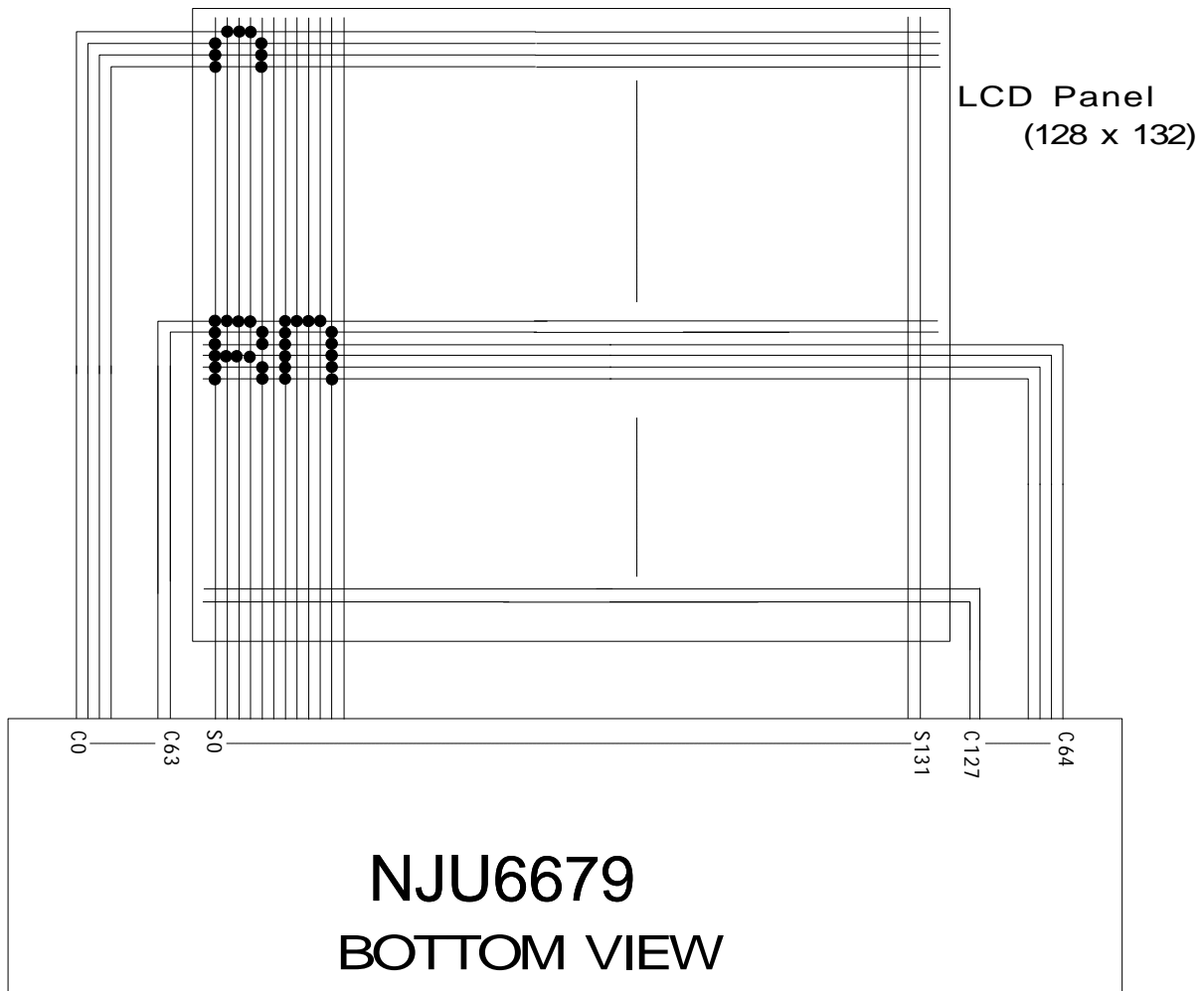

■ CAUTION

The specifications on this databook are only given for information, without any guarantee as regards either mistakes or omissions. The application circuits in this databook are described only to show representative usages of the product and not intended for the guarantee or permission of any right including the industrial rights.