

## Features

- Fast Read Access Time - 70ns
- Low-Power CMOS Operation
  - 100  $\mu$ A max. Standby
  - 20 mA max. Active at 5 MHz
- JEDEC Standard Packages
  - 28-Lead 600-mil Windowed CDIL
  - 32-Lead Windowed LCC/JLCC
  - 28-Lead Custom
- 5V  $\pm$  10% Supply
- High-Reliability Atmel CMOS die Technology
  - 2,000V ESD Protection
  - 200 mA Latchup Immunity
- Rapid™ Atmel Programming Algorithm - 100 mms/byte (typical)
- CMOS and TTL Compatible Inputs and Outputs
- Integrated Product Identification Code
- Commercial, Industrial, Mil Temperature Ranges inc Hi-Rel /DMB/8 883 5004/5005

## Description

The FT27C512R is a low-power, high-performance 524,288-bit UV erasable programmable read only memory (UVEPROM) organized 64K by 8 bits. It requires only one 5V power supply in normal read mode operation. Any byte can be accessed in less than 45 ns, eliminating the need for speed reducing WAIT states on high-performance microprocessor systems.

Atmel's die in CMOS technology provides high-speed, lower active power consumption, and significantly faster programming. Power consumption is typically only 8 mA in Active Mode and less than 10  $\mu$ A in Standby.

(continued)

## Pin Configurations

Pin Name	Function
A0 to A15	Addresses
O0 - O7	Outputs
$\overline{CE}$	Chip Enable
$\overline{OE}/VPP$	Output Enable/VPP
NC	No Connect

CDIL Top View

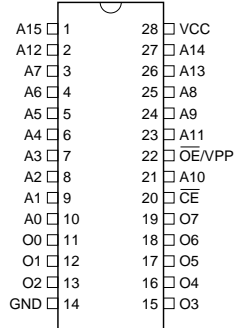

LCC/JLCC Top View

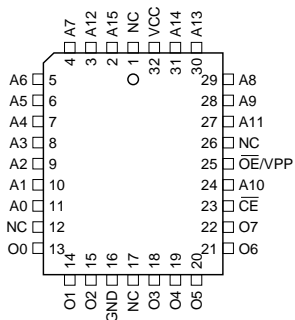

Note: LCC/JLCC Package Pins 1 and 17 are DON'T CONNECT.

512K (64K x 8)  
UVEPROM

FT27C512R

---

The FT27C512R is available in a choice of industry standard JEDEC-approved UV erasable re-programmable Ceramic CDIL, LCC, JLCC, Custom packages. All devices feature two-line control ( $\overline{CE}$ ,  $\overline{OE}$ ) to give designers the flexibility to prevent bus contention.

With 64K byte storage capability, the FT27C512R allows firmware to be stored reliably and to be accessed by the system without the delays of mass storage media.

Force's 27C512R has additional features to ensure high quality and efficient production use. The Rapid™ Programming Algorithm reduces the time required to program the part and guarantees reliable programming. Programming time is typically only 100  $\mu$ s/byte. The Integrated Product Identification Code electronically identifies the device and manufacturer. This feature is used by industry standard programming equipment to select the proper programming algorithms and voltages. Atmel die gives Atmel signature.

## System Considerations

Switching between active and standby conditions via the Chip Enable pin may produce transient voltage excursions. Unless accommodated by the system design, these transients may exceed data sheet limits, resulting in device non-conformance. At a minimum, a 0.1  $\mu$ F high frequency, low inherent inductance, ceramic capacitor should be utilized for each device. This capacitor should be connected between the  $V_{CC}$  and Ground terminals of the device, as close to the device as possible. Additionally, to stabilize the supply voltage level on printed circuit boards with large EPROM arrays, a 4.7  $\mu$ F bulk electrolytic capacitor should be utilized, again connected between the  $V_{CC}$  and Ground terminals. This capacitor should be positioned as close as possible to the point where the power supply is connected to the array.

## Block Diagram

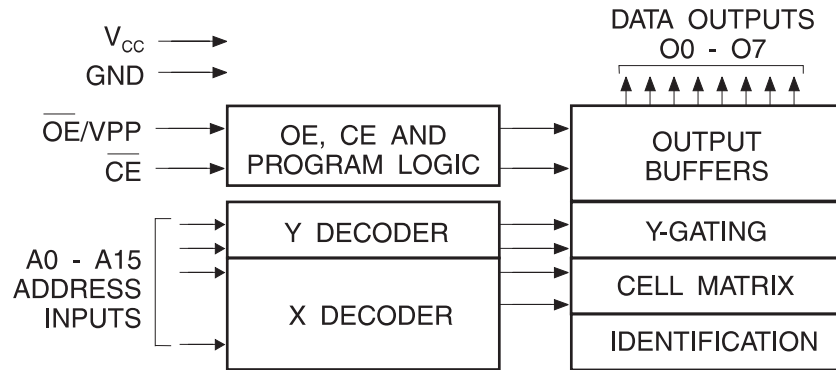

## Absolute Maximum Ratings\*

Temperature Under Bias.....	-55°C to + 125°C
Storage Temperature .....	-65°C to + 150°C
Voltage on Any Pin with Respect to Ground .....	-2.0V to + 7.0V <sup>(1)</sup>
Voltage on A9 with Respect to Ground .....	-2.0V to + 14.0V <sup>(1)</sup>
V <sub>PP</sub> Supply Voltage with Respect to Ground .....	-2.0V to + 14.0V <sup>(1)</sup>

**\*NOTICE:** Stresses beyond those listed under “Absolute Maximum Ratings” may cause permanent damage to the device. This is a stress rating only and functional operation of the device at these or any other conditions beyond those indicated in the operational sections of this specification is not implied. Exposure to absolute maximum rating conditions for extended periods may affect device reliability.

**Note:** 1. Minimum voltage is -0.6V dc which may undershoot to -2.0V for pulses of less than 20 ns. Maximum output pin voltage is V<sub>CC</sub> + 0.75V dc which may overshoot to +7.0 volts for pulses of less than 20 ns.

## Operating Modes

Mode\Pin	$\overline{CE}$	$\overline{OE}/V_{PP}$	Ai	Outputs
Read	V <sub>IL</sub>	V <sub>IL</sub>	Ai	D <sub>OUT</sub>
Output Disable	V <sub>IL</sub>	V <sub>IH</sub>	X <sup>(1)</sup>	High Z
Standby	V <sub>IH</sub>	X <sup>(1)</sup>	X	High Z
Rapid Program <sup>(2)</sup>	V <sub>IL</sub>	V <sub>PP</sub>	Ai	D <sub>IN</sub>
PGM Inhibit	V <sub>IH</sub>	V <sub>PP</sub>	X <sup>(1)</sup>	High Z
Product Identification <sup>(4)</sup>	V <sub>IL</sub>	V <sub>IL</sub>	A9 = V <sub>H</sub> <sup>(3)</sup> A0 = V <sub>IH</sub> or V <sub>IL</sub> A1 - A15 = V <sub>IL</sub>	Identification Code

- Notes:
- X can be V<sub>IL</sub> or V<sub>IH</sub>.
  - Refer to Programming Characteristics.
  - V<sub>H</sub> = 12.0 ± 0.5V.
  - Two identifier bytes may be selected. All Ai inputs are held low (V<sub>IL</sub>), except A9 which is set to V<sub>H</sub> and A0 which is toggled low (V<sub>IL</sub>) to select the Manufacturer's Identification byte and high (V<sub>IH</sub>) to select the Device Code byte.

## DC and AC Operating Conditions for Read Operation

		FT27C512R					
		-45	-55	-70	-90	-12	-15
Operating Temp.(Case)	Com.			0°C - 70°C	0°C - 70°C	0°C - 70°C	0°C - 70°C
	Ind.			-40°C - 85°C	-40°C - 85°C	-40°C - 85°C	-40°C - 85°C
	Mil			-55oC-125oC	-55oC-125oC	-55oC-125oC	-55oC-125oC
V <sub>CC</sub> Supply		5V ± 10%	5V ± 10%	5V ± 10%	5V ± 10%	5V ± 10%	5V ± 10%

## DC and Operating Characteristics for Read Operation

Symbol	Parameter	Condition	Min	Max	Units	
I <sub>LI</sub>	Input Load Current	V <sub>IN</sub> = 0V to V <sub>CC</sub>	Com., Ind,		±1	μA
			Mil.		±5	mA
I <sub>LO</sub>	Output Leakage Current	V <sub>OUT</sub> = 0V to V <sub>CC</sub>	Com., Ind,		±5	μA
			Mil.		±10	mA
I <sub>SB</sub>	V <sub>CC</sub> <sup>(1)</sup> Standby Current	I <sub>SB1</sub> (CMOS), $\overline{CE} = V_{CC} \pm 0.3V$		100	μA	
		I <sub>SB2</sub> (TTL), $\overline{CE} = 2.0$ to V <sub>CC</sub> + 0.5V		1	mA	
I <sub>CC</sub>	V <sub>CC</sub> Active Current	f = 5 MHz, I <sub>OUT</sub> = 0 mA, $\overline{CE} = V_{IL}$ /Ind,mil		20/25	mA	
V <sub>IL</sub>	Input Low Voltage		-0.6	0.8	V	
V <sub>IH</sub>	Input High Voltage		2.0	V <sub>CC</sub> + 0.5	V	
V <sub>OL</sub>	Output Low Voltage	I <sub>OL</sub> = 2.1 mA		0.4	V	
V <sub>OH</sub>	Output High Voltage	I <sub>OH</sub> = -400 μA	2.4		V	

Notes: 1. V<sub>CC</sub> must be applied simultaneously with or before  $\overline{OE}/V_{PP}$  and removed simultaneously with or after  $\overline{OE}/V_{PP}$ .

## AC Characteristics for Read Operation

Symbol	Parameter	Condition	FT27C512R										Units		
			-45		-55		-70		-90		-12			-15	
			Min	Max	Min	Max	Min	Max	Min	Max	Min	Max		Min	Max
t <sub>ACC</sub> <sup>(3)</sup>	Address to Output Delay	$\overline{CE} = \overline{OE}/V_{PP} = V_{IL}$						70	90			120		150	ns
t <sub>CE</sub> <sup>(2)</sup>	$\overline{CE}$ to Output Delay	$\overline{OE}/V_{PP} = V_{IL}$						70	90			120		150	ns
t <sub>OE</sub> <sup>(2)(3)</sup>	$\overline{OE}/V_{PP}$ to Output Delay	$\overline{CE} = V_{IL}$						30	35			35		40	ns
t <sub>DF</sub> <sup>(4)(5)</sup>	$\overline{OE}/V_{PP}$ or $\overline{CE}$ High to Output Float, whichever occurred first							25	25			30		35	ns
t <sub>OH</sub>	Output Hold from Address, $\overline{CE}$ or $\overline{OE}/V_{PP}$ whichever occurred first							0	0			0		0	

Notes: 2, 3, 4, 5. - see AC Waveforms for Read Operation.

## AC Waveforms for Read Operation<sup>(1)</sup>

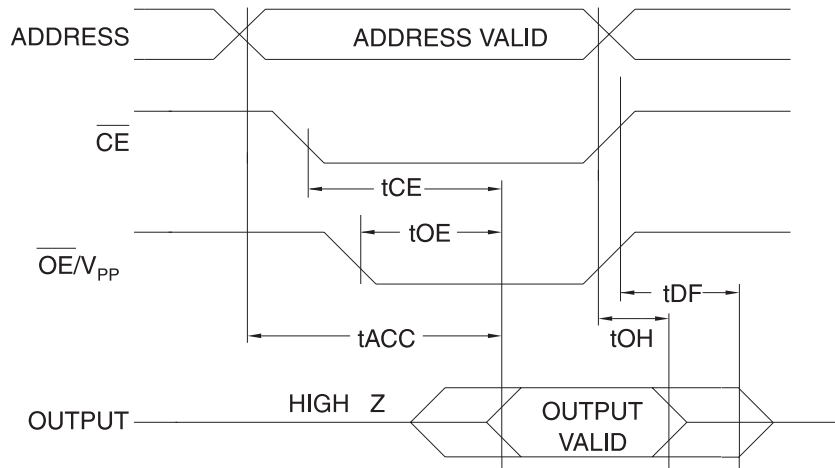

- Notes:
1. Timing measurement reference level is 1.5V for -45 and -55 devices. Input AC drive levels are  $V_{IL} = 0.0V$  and  $V_{IH} = 3.0V$ . Timing measurement reference levels for all other speed grades are  $V_{OL} = 0.8V$  and  $V_{OH} = 2.0V$ . Input AC drive levels are  $V_{IL} = 0.45V$  and  $V_{IH} = 2.4V$ .
  2.  $\overline{OE}/V_{PP}$  may be delayed up to  $t_{CE} - t_{OE}$  after the falling edge of  $\overline{CE}$  without impact on  $t_{CE}$ .
  3.  $\overline{OE}/V_{PP}$  may be delayed up to  $t_{ACC} - t_{OE}$  after the address is valid without impact on  $t_{ACC}$ .
  4. This parameter is only sampled and is not 100% tested.
  5. Output float is defined as the point when data is no longer driven.

## Input Test Waveforms and Measurement Levels

For -45 and -55 devices only:

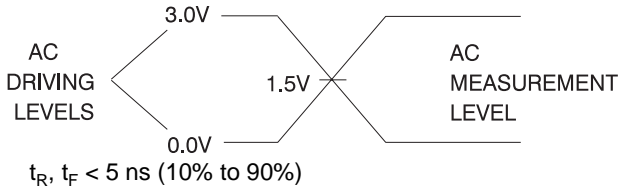

For -70, -90, -12, -15, and -20 devices:

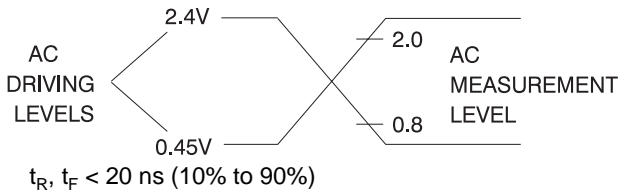

## Output Test Load

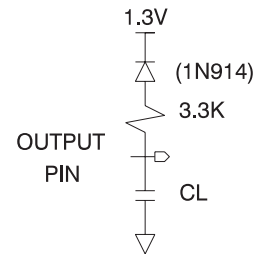

Note:  $C_L = 100$  pF including jig capacitance, except for the -45 and -55 devices, where  $C_L = 30$  pF.

## Pin Capacitance

( $f = 1$  MHz  $T = 25^\circ C$ )<sup>(1)</sup>

	Typ	Max	Units	Conditions
$C_{IN}$	4	6	pF	$V_{IN} = 0V$
$C_{OUT}$	8	12	pF	$V_{OUT} = 0V$

Note: 1. Typical values for nominal supply voltage. This parameter is only sampled and is not 100% tested.

## Programming Waveforms<sup>(1)</sup>

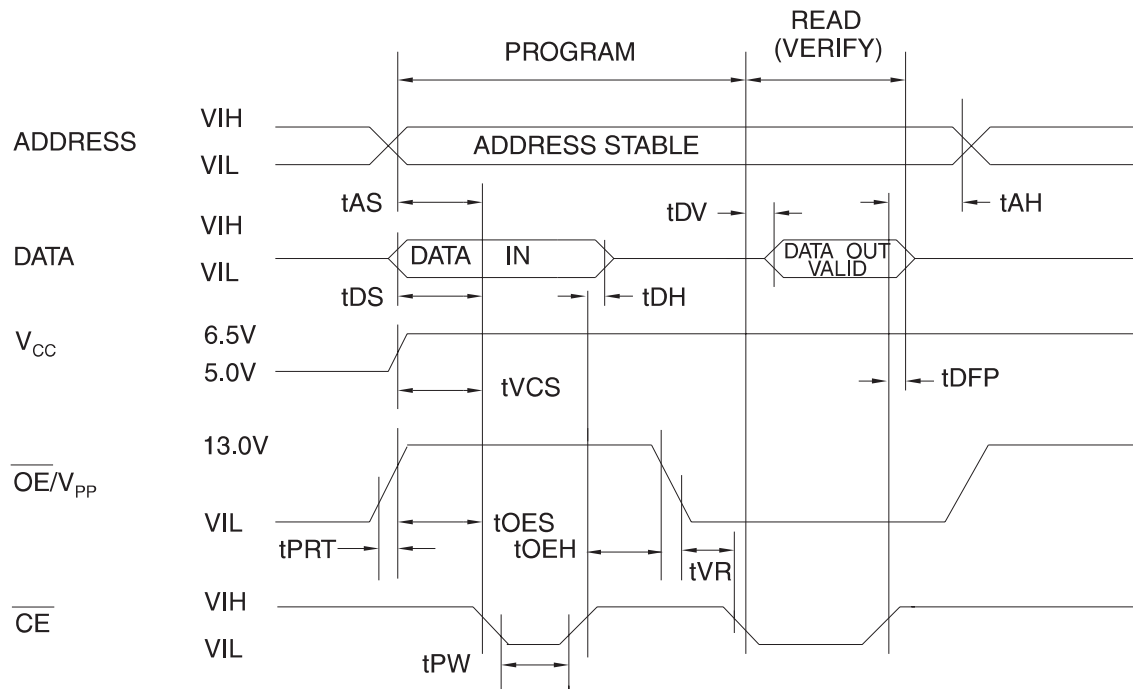

- Notes: 1. The Input Timing Reference is 0.8V for  $V_{IL}$  and 2.0V for  $V_{IH}$ .  
 2.  $t_{OE}$  and  $t_{DFP}$  are characteristics of the device but must be accommodated by the programmer.

## DC Programming Characteristics

$T_A = 25 \pm 5^\circ\text{C}$ ,  $V_{CC} = 6.5 \pm 0.25\text{V}$ ,  $\overline{OE}/V_{PP} = 13.0 \pm 0.25\text{V}$

Symbol	Parameter	Test Conditions	Limits		Units
			Min	Max	
$I_{LI}$	Input Load Current	$V_{IN} = V_{IL}, V_{IH}$		$\pm 10$	$\mu\text{A}$
$V_{IL}$	Input Low Level		-0.6	0.8	V
$V_{IH}$	Input High Level		2.0	$V_{CC} + 1$	V
$V_{OL}$	Output Low Voltage	$I_{OL} = 2.1 \text{ mA}$		0.4	V
$V_{OH}$	Output High Voltage	$I_{OH} = -400 \mu\text{A}$	2.4		V
$I_{CC2}$	$V_{CC}$ Supply Current (Program and Verify)			25	mA
$I_{PP2}$	$\overline{OE}/V_{PP}$ Current	$\overline{CE} = V_{IL}$		25	mA
$V_{ID}$	A9 Product Identification Voltage		11.5	12.5	V

### AC Programming Characteristics

$T_A = 25 \pm 5^\circ\text{C}$ ,  $V_{CC} = 6.5 \pm 0.25\text{V}$ ,  $\overline{OE}/V_{PP} = 13.0 \pm 0.25\text{V}$

Symbol	Parameter	Test Conditions <sup>(1)</sup>	Limits		Units
			Min	Max	
$t_{AS}$	Address Setup Time	Input Rise and Fall Times (10% to 90%) 20ns	2		$\mu\text{s}$
$t_{OES}$	$\overline{OE}/V_{PP}$ Setup Time		2		$\mu\text{s}$
$t_{OEH}$	$\overline{OE}/V_{PP}$ Hold Time		2		$\mu\text{s}$
$t_{DS}$	Data Setup Time		2		$\mu\text{s}$
$t_{AH}$	Address Hold Time	Input Pulse Levels 0.45V to 2.4V	0		$\mu\text{s}$
$t_{DH}$	Data Hold Time		2		$\mu\text{s}$
$t_{DFP}$	$\overline{CE}$ High to Output Float Delay <sup>(2)</sup>	Input Timing Reference Level	0	130	ns
$t_{VCS}$	$V_{CC}$ Setup Time	0.8V to 2.0V	2		$\mu\text{s}$
$t_{PW}$	$\overline{CE}$ Program Pulse Width <sup>(3)</sup>	Output Timing Reference Level 0.8V to 2.0V	95	105	$\mu\text{s}$
$t_{DV}$	Data Valid from $\overline{CE}$ <sup>(2)</sup>			1	$\mu\text{s}$
$t_{VR}$	$\overline{OE}/V_{PP}$ Recovery Time		2		$\mu\text{s}$
$t_{PRT}$	$\overline{OE}/V_{PP}$ Pulse Rise Time During Programming		50		ns

- Notes:
- $V_{CC}$  must be applied simultaneously or before  $\overline{OE}/V_{PP}$  and removed simultaneously or after  $\overline{OE}/V_{PP}$
  - This parameter is only sampled and is not 100% tested. Output Float is defined as the point where data is no longer driven—see timing diagram.
  - Program Pulse width tolerance is  $100 \mu\text{sec} \pm 5\%$ .

### FT27C512R Integrated Product Identification Code-Atmel Die

Codes	Pins									Hex Data
	A0	O7	O6	O5	O4	O3	O2	O1	O0	
Manufacturer	0	0	0	0	1	1	1	1	0	1E
Device Type	1	0	0	0	0	1	1	0	1	0D

## Rapid Programming Algorithm

A  $100\ \mu\text{s}$   $\overline{\text{CE}}$  pulse width is used to program. The address is set to the first location.  $V_{\text{CC}}$  is raised to 6.5V and  $\overline{\text{OE}}/V_{\text{PP}}$  is raised to 13.0V. Each address is first programmed with one  $100\ \mu\text{s}$   $\overline{\text{CE}}$  pulse without verification. Then a verification/reprogramming loop is executed for each address. In the event a byte fails to pass verification, up to 10 successive  $100\ \mu\text{s}$  pulses are applied with a verification after each

pulse. If the byte fails to verify after 10 pulses have been applied, the part is considered failed. After the byte verifies properly, the next address is selected until all have been checked.  $\overline{\text{OE}}/V_{\text{PP}}$  is then lowered to  $V_{\text{IL}}$  and  $V_{\text{CC}}$  to 5.0V. All bytes are read again and compared with the original data to determine if the device passes or fails.

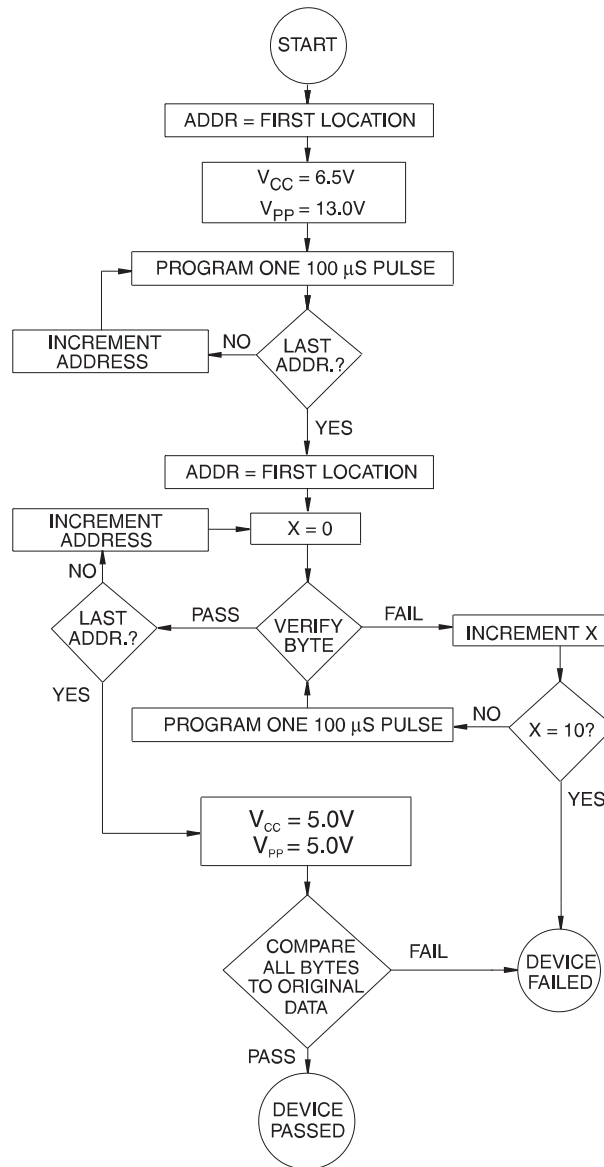

**Ordering Information**

$t_{ACC}$ (ns)	$I_{CC}$ (mA)		Ordering Code	Package	Operation Range
	Active	Standby			
<b>70</b>	<b>20</b>	<b>0.1</b>	<b>FT27C512R-XXDC</b> <b>FT27C512R-XXLC</b> <b>FT27C512R-XXKC</b> <b>FT27C512R-XX-xxx</b>	<b>WinCDIL</b> <b>WinLCC</b> <b>WinJLCC</b> <b>xxx-Custom</b>	Commercial (0°C to 70°C)
	<b>20</b>	<b>0.1</b>	<b>FT27C512R-XXDI</b> <b>FT27C512R-XXLI</b> <b>FT27C512R-XXKI</b> <b>FT27C512R-XXTI-xxx</b>	<b>WinCDIL</b> <b>WinLCC</b> <b>WinJLCC</b> <b>xxx-Custom</b>	Industrial (-40°C to 85°C)
	<b>20</b>	<b>0.1</b>	<b>FT27C512R-XXDM</b> <b>FT27C512R-XXLM</b> <b>FT27C512R-XXKM</b>	<b>WinCDIL</b> <b>WinLCC</b> <b>WinJLCC</b>	Military (-55°C to 125°C)

Package Type	
JLCC	32-Lead, Ceramic J-Leaded Windowed Chip Carrier (JLCC)
CDIL	28-Lead, 0.600" Wide, Ceramic Windowed Dual Inline Package (PDIP)
LCC	32-Lead, Ceramic Windowed LCC (LCC)
DMB/DMB8	DMB=tested to Mil-Std-883 Method 5004    DMB8=tested to Mil-Std-883 method 5005



Ashley Crt, Henley,  
Marlborough, Wilts, SN8 3RH UK

**Tel: +44(0)1264 731200**

**Fax:+44(0)1264 731444**

E-mail

[info@forcetechnologies.co.uk](mailto:info@forcetechnologies.co.uk)

[tech@forcetechnologies.co.uk](mailto:tech@forcetechnologies.co.uk)

[sales@forcetechnologies.co.uk](mailto:sales@forcetechnologies.co.uk)

**[www.forcetechnologies.co.uk](http://www.forcetechnologies.co.uk)**

Unless otherwise stated in this SCD/Data sheet, Force Technologies Ltd reserve the right to make changes, without notice, in the products, including circuits, cells and/or software, described or contained herein in order to improve design and/or performance. Force Technologies assumes no responsibility or liability for the use of any of these products, conveys no licence or any title under patent, copyright, or mask work to these products, and makes no representation or warranties that that these products are free from patent, copyright or mask work infringement, unless otherwise specified.

**Life Support Applications**

Force Technologies products are not designed for use in life support appliances, devices or systems where malfunction of a Force Technologies product can reasonably be expected to result in a personal injury. Force Technologies customers using or selling Force Technologies products for use in such applications do so at their own risk and agree to fully indemnify Force Technologies for any damages resulting from such improper use or sale.

All trademarks acknowledged

Copyright Force Technologies Ltd 2003