



## PTCR Overcurrent Protection

### FEATURES:

**Sizes For Your Application** - Hold currents from 5 mA to 1.5 A are available in sizes from 4 to 22mm.

**Better Protection, Maintenance Free** - PTCRs reset after an overcurrent situation. Protection levels may be set lower than possible with fuses, without worrying about nuisance trips.

**Resetting, Non Cycling** - Functioning as a manual reset device, PTCR overcurrent protectors remain latched in the tripped state and automatically reset only after voltage has been removed. This prevents continuous cycling, and protects against reclosing into a fault condition.

**Simplified Mounting** - PTCRs may be mounted directly inside end use equipment. Unlike fuses, no bulky fuseholder or access for user replacement is required.

**Ceramic Material Selection** - Various curie materials are available to tailor hold and trip current operating points.

**Repeatable, No Hysteresis** - After resetting, ceramic PTCRs return to the initial resistance value, providing repeatable, consistent protection levels. Unlike polymer type PTCRs, Vishay Cera-Mite devices exhibit no resistance hysteresis application problems.

**Telecom Line Balance** - In telecom circuits matched pairs are used to maintain line balance. Unlike polymer PTCRs, ceramic devices maintain balance after resetting.

### APPLICATION DATA

In a typical current limiter application, the PTC device is connected in series with a load impedance (**Fig P-1**). When current (I) flows, internal I<sup>2</sup>R losses attempt to increase the PTCR's temperature. To maintain the low resistance "on" state, stabilization must occur below the switching temperature, where the heat generated (I<sup>2</sup>R) is balanced by heat lost due to radiation and conduction.

Hold current (I<sub>H</sub>) is the maximum continuous current at which a PTCR can be maintained in a low resistance "on" state while operating at rated ambient temperature (typ 25°C). To prevent nuisance tripping, choose the rated hold current to be greater than the normal current expected.

Since heat dissipated by the device is proportional to the ambient temperature, hold current must be derated for ambients higher than 25°C according to the following relationship:

$$\text{Hold Current (I}_H) = \sqrt{\frac{D(T_{SW} - T_A)}{R_{PTC}}}$$

Where:

D = Dissipation Constant (varies based on disc size, wire type, & coating material)

T<sub>SW</sub> = Switching (Curie) Temperature of PTCR Material

T<sub>A</sub> = Ambient Temperature

R<sub>PTC</sub> = Resistance of PTCR at 25°C

Fig P-1

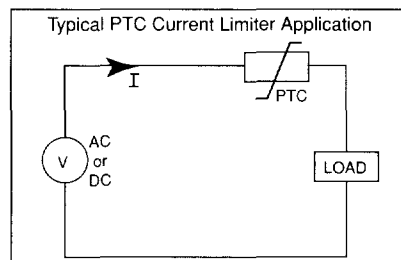

### A NEW DIMENSION

The Positive Temperature Coefficient Resistor's (PTC thermistor) unique property of dramatically increasing its resistance above the curie temperature makes it an excellent candidate for overcurrent protection applications. Overcurrent situations in electronic devices occur due to voltage fluctuations, changes in load impedance, or problems with system wiring. PTC thermistors monitor current in series connected loads, trip in the event of excess current, and reset after the overload situation is removed, creating a new dimension of flexibility for designers.

### APPLICATIONS:

- Telecommunication Products
- Electronic Power Supplies
- Automotive Motor Protection
- Industrial Control Systems

This relationship is shown in **Fig P-2**, which provides hold current (I<sub>H</sub>) derating estimates for ambient temperatures in excess of 25°C. Five curie materials illustrate the design flexibility offered by ceramic PTCR's.

Fig P-2

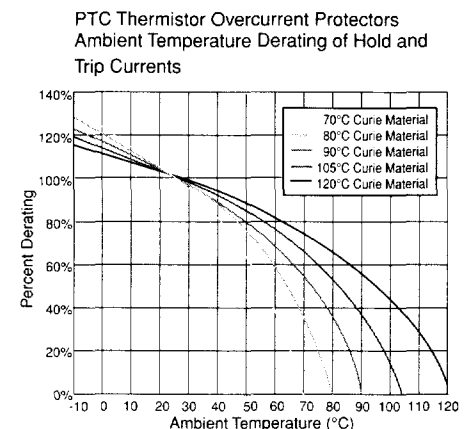



### APPLICATION DATA

#### TRIPPING ACTION DUE TO OVERCURRENT

During normal operation, the PTCR remains in a low base resistance state (Fig P-3, Region 1). However, if current in excess of hold current ( $I_H$ ) is conducted,  $I^2R$  losses produce internal self heating. If the magnitude and time of the overcurrent event develops an energy input in excess of the device's ability to dissipate heat, the PTCR temperature will increase, thus reducing the current and protecting the circuit.

PTC current limiters are intended for service on telecom systems, automobiles, or the secondary of control transformers or in similar applications where energy available is limited by source impedance. They are not intended for application on AC line voltages where source energy may be high and source impedance low.

The current required to trip ( $I_T$ ) is typically specified as two times the hold current ( $2 \times I_H$ ).  $I_T$  is defined as the minimum rms conduction current required to guarantee thermistor switching into a high resistance state (Fig P-3, Region 2) at a 25°C ambient temperature.

Ambient temperature influences the ability of the PTCR to transfer heat via surface radiation and thermal conduction at the wire leads. At high ambient temperatures, less energy input (via  $I^2R$ ) is required to reach the trip temperature. Low ambients require greater energy input. Approximate derating effects are shown in Fig P-2.

### CERAMIC MATERIALS

The temperature at which the PTCR changes from the base resistance to high resistance region is determined by the PTCR ceramic material. Switching temperature ( $T_{sw}$ ) described by the boundary between regions 1 & 2 (Fig P-3), is the temperature point at which the PTCR has increased to two times its base resistance at 25°C ambient ( $R_{sw} = 2 \times R_{25}$ ). Design flexibility is enhanced by Cera-Mite's wide selection of ceramic PTCR materials with different switching temperatures (Fig P-4).

Fig P-4

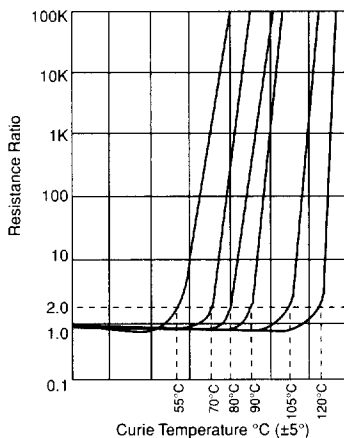

Vishay Cera-Mite offers a wide selection of ceramic PTC materials providing flexibility for different ambient temperatures. Close protection levels are possible by designing resistance and physical size to meet specific hold current and trip current requirements.

### SELF RESETTING - NON CYCLING - REPEATABLE

After tripping, the PTCR will remain latched in its high resistance state as long as voltage remains applied and sufficient trickle current is maintained to keep the device above the switching temperature. After voltage is removed, the PTCR resets (cools) back to its low resistance state and is again ready to provide protection.

Since the tripping operation is due to thermal change, there is a time-trip curve associated with each device. At relatively low magnitudes of overcurrent, it may take minutes for the device to trip. Higher current levels can result in millisecond response time. Trip time (t) can be calculated as follows

$$\text{Trip Time (t)} = \frac{kM(T_{sw} - T_A)}{I^2R - D(T_{sw} - T_A)}$$

Where:  $k$  = coefficient of heat absorption = 0.603 J/g/°C  
 $M$  = mass of PTCR = volume  $\times$  5.27x10<sup>-3</sup> g/mm<sup>3</sup>  
 $R$  = zero power resistance of PTCR at 25°C

Fig P-3

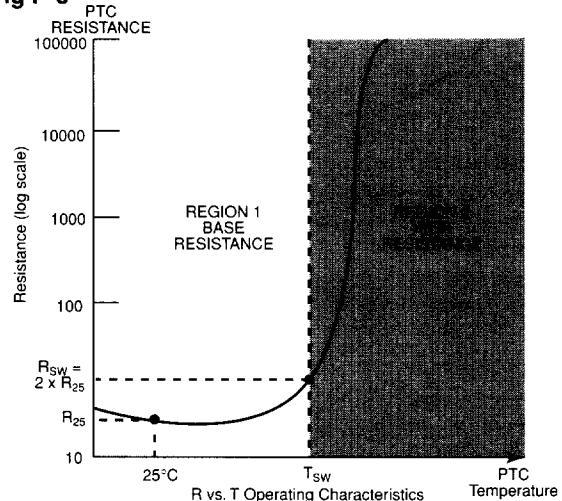

### PHYSICAL DESIGN CONSIDERATIONS

- Diameter (D) - Common diameters range from 4 to 22mm.
- Thickness (T) - Typical thickness ranges from 1 to 5mm.
- Curie (Switching) Temperature ( $T_{sw}$ ) - See Fig P-4.
- Resistivity ( $\rho$ ) -

Determined during sintering process; combined with pellet geometry results in final resistance based on:

$$R_{25} = \text{zero power resistance at } 25^\circ\text{C} = \frac{\rho T}{\text{Area}}$$

Table 2

How Various Physical Parameters Influence a PTCs:		
PARAMETER	VOLTAGE & CURRENT CAPABILITY	HOLD CURRENT & TRIP TIME
Disc Diameter (D)	Increased diameter will increase voltage and current ratings.	Increased diameter will increase hold current and lengthen trip time.
Disc Thickness (T)	Increased thickness will increase voltage rating; may or may not increase current rating.	Increased thickness will increase hold current and lengthen trip time.
Curie (Switch) Temperature ( $T_{sw}$ )	Typically, lower switch temperature materials have higher voltage/current capability.	Higher switch temperature materials increase hold current and lengthen trip time.
Resistance ( $R_{25}$ )	Higher resistance will increase voltage capability.	Lower resistance will increase hold current and lengthen trip times.
Thermal Loading (Heat Sink) Wire Leads	Increased thermal loading typically reduces the maximum interrupting current. Wire leads added to a PTCR pellet act as a thermal load resulting in reduced maximum interrupting current.	Increased thermal loading increases hold current and lengthens trip times. Depends on thermal conductivity of wire used. Copper will increase hold current and trip time.
Coating Material	Applying coating to a leaded PTCR has minimal effect on voltage/current ratings.	Applying coating to a leaded PTCR increases hold current/trip time 10-20%.



# 307C Overcurrent Thermistors

PTCR Overcurrent Protection

Vishay Cera-Mite

Fig P-5

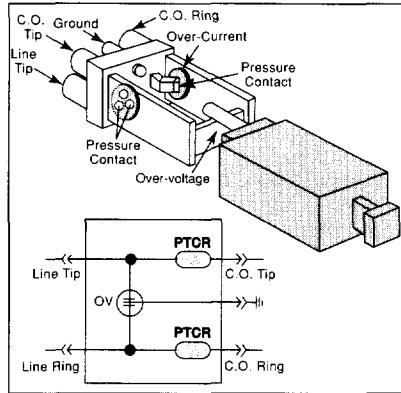
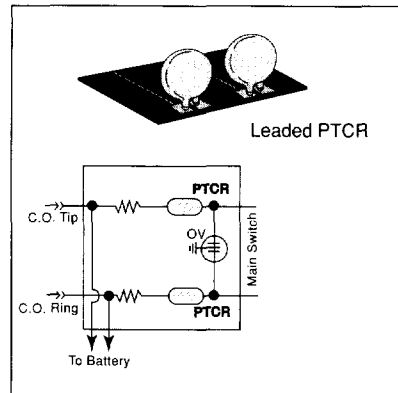

Fig P-6



## PTC THERMISTORS FOR TELECOMMUNICATIONS

PTC Thermistors provide protection for large digital switches. Vishay Cera-Mite has pioneered this field with ceramic PTC thermistors working closely with major telephone equipment and telephone protection manufacturers. The requirements are dynamic, as switch makers continually strive to protect at lower levels. Vishay Cera-Mite participates with industry standard technical committees to establish common definitions and understanding of this new technology.

Fig P-8

Time-Trip Curves for Popular Telecom Pellets

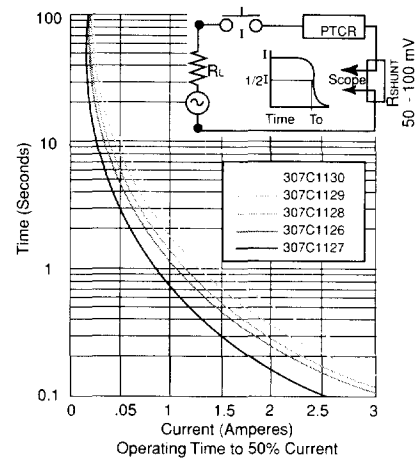

## PTC THERMISTOR PELLETS FOR TELECOMMUNICATIONS

Table 2

HOLD CURRENT (I <sub>H</sub> ) mA	TRIP CURRENT (I <sub>T</sub> ) mA	RESISTANCE R <sub>25</sub> Ohms	SWITCH TEMP. °C	SIZE (D) NOMINAL mm	VISHAY CERA-MITE PART NUMBER
110	220	30	105	6.5	307C1127
100	200	15	70	8	307C1128
100	200	20	80	8	307C1126
110	220	18	80	8	307C1268
120	240	15	80	8	307C1129
140	280	15	105	8	307C1435
110	220	15	70	9.5	307C1134
130	260	15	80	9.5	307C1130
140	280	9	70	9.5	307C1436
150	300	10	80	9.5	307C1437

Fig P-7

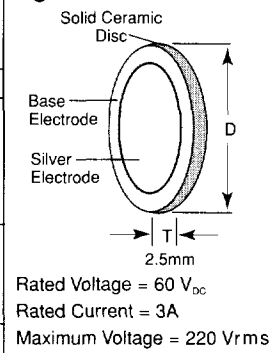

**Note 1**

Hold and trip currents are specified at 25°C ambient.

**Note 2**

R<sub>25</sub> is nominal zero power resistance at 25°C with tolerance of ± 20%.

**Note 3**

All pellets have silver electrodes suitable for pressure contact mounting.

## INTERRUPTING CAPACITY ESTIMATES

Under unusual circumstances, telecommunication lines may be subjected to high surge currents as might occur from lightning effects or accidental crossing with power lines or transformer primaries.

Fig P-10 shows trip time curves for higher currents. Estimated interrupting capability data is also shown in Table 3 and is expressed as "I<sup>2</sup>t Let Through" based on test data conducted in accordance with UL 497A and CSA 22.2 No. 0.7-M1985.

The data shown is for reference. Specific short circuit data or interrupting capability is partially determined by the mounting means and circuit application.

Fig P-9

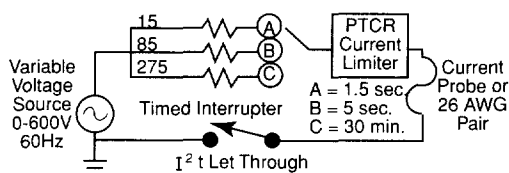
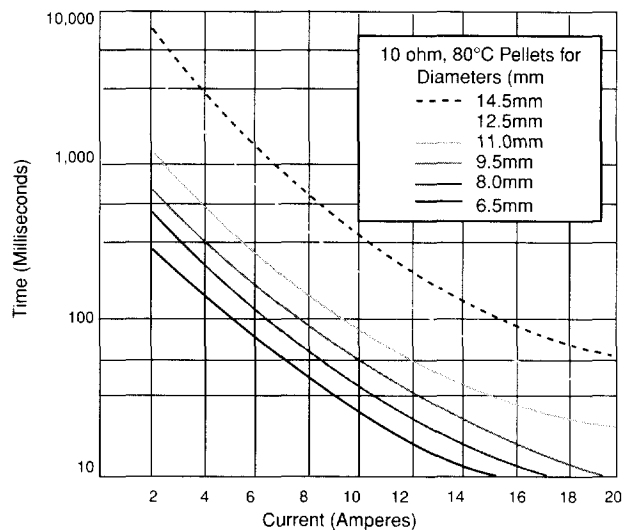

Fig P-10

Time VS. Current Curves for High Current Surges (25°C)



# 307C Overcurrent Thermistors



Vishay Cera-Mite

PTCR Overcurrent Protection

## CUSTOM PTCR PELLET DESIGN CAPABILITY

- Vishay Cera-Mite will customize solid state overcurrent protector PTCRs to your exact requirements for telecommunication, power supply, or general electronic use. Providing great flexibility to establish specific voltage, hold current, time-trip characteristic, and ambient temperature values.
- Each device must be evaluated and ratings established per application. Mechanical packaging influences performance ratings.

Table 3

RATING CHART FOR CUSTOM PELLETS						
DISC DIAMETER (2.5mm THICK)	6.5mm	8mm	9.5mm	11mm	12.5mm	14.5mm
Continuous Voltage Rating (rms) (proportional to resistance)	100 – 300	100 – 300	100 – 300	100 – 300	100 – 300	50 – 300
Resistance Range @ 25°C (ohms)	10 to 35	7 to 25	5 to 20	4 to 17	2 to 15	1 to 10
Continuous Carry Current (mA) Ambient 25° to 50°C (inversely proportional to resistance)	60 – 120	75 – 175	100 – 200	110 – 250	130 – 400	150 – 600
Approximate Minimum Power to Trip or Reset (watts)	0.4	0.5	0.6	0.7	0.8	0.9
Interrupting Capability						
A. Repetitive (25 to 300 V <sub>RMS</sub> ) Peak power in watts	600	700	800	900	1000	1100
B. Non-repetitive (for 10 ohm pellet) I <sup>2</sup> t Let Through	2.5	4.0	7.5	15	20	30
Maximum Safe Interrupting Voltage (rms) (voltage rating is proportional to resistance)	300	350	400	450	500	600

Rating applies to pellets with silver electrodes and pressure connections.

## TRANSIENT VOLTAGE & CURRENT

Because of the thermal storage capacity of the ceramic PTCR, transient surges do not cause tripping. The PTCR is considered to be transparent to these low energy transients. Fig P-11 shows a typical test circuit for such transients.

Fig P-11

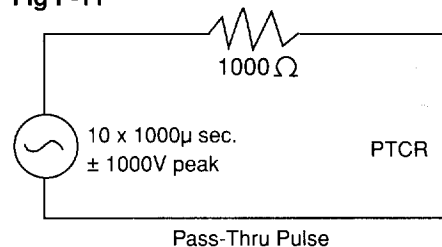

## WIRE LEADED PTC TELECOM THERMISTORS

Resettable current limiters featuring hold current and voltage ratings for telecommunication applications.

Fig P-12

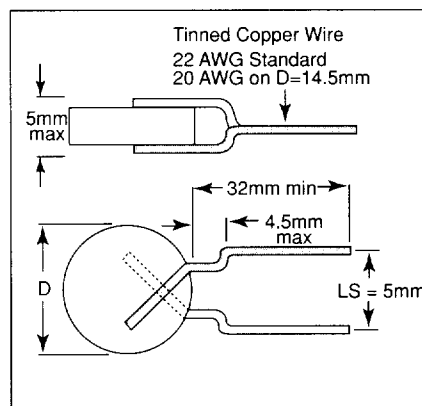

Table 4

TELECOM CURRENT LIMITERS							
HOLD (I <sub>H</sub> ) CURRENT mA	TRIP (I <sub>T</sub> ) CURRENT mA	RESISTANCE R <sub>25</sub> Ohms	TOL. %	SWITCH TEMP. °C	SIZE (D) NOMINAL mm	MAX. VOLTAGE V <sub>RMS</sub>	VISHAY CERA-MITE PART NUMBER
70	140	100	25	120	6.5	265	307C1418
100	200	20	20	80	8	220	307C1305
100	200	30	20	105	8	220	307C1506
110	220	18	20	80	8	220	307C1354
110	220	25	20	105	8	220	307C1514
120	240	15	20	80	8	220	307C1129
120	240	20	20	105	8	220	307C1296
120	240	25	20	120	8	220	307C1470
130	260	13	20	80	8	120	307C1421
120	240	39	30	120	8.7	250	307C1505
120	240	25	25	105	8.7	250	307C1501
150	300	12	20	90	8.7	110	307C1439
120	240	15	25	80	9.5	220	307C1465
125	250	20	20	105	9.5	220	307C1507
135	270	10	25	80	9.5	220	307C1469
150	300	10	20	105	9.5	220	307C1233
170	340	10	20	105	11.2	220	307C1234
110	220	23	20	80	14.5	300	307C1262
125	250	18	25	80	14.5	265	307C1254

**Note 1**  
Hold and trip currents specified at 25°C ambient.

**Note 2**  
R<sub>25</sub> is nominal zero power resistance (± 25%) at 25°C.

**Note 3**  
P/N suffix describes options including:  
Tape & Reel  
Wire Size  
Wire Style & Length  
Lead Spacing  
Coating Material

Rated Voltage = 60Vdc; Rated Current = 3A at rated voltage.



# 307C Overcurrent Thermistors

PTCR Overcurrent Protection

Vishay Cera-Mite

Table 5

GENERAL PURPOSE PTC THERMISTORS OVERCURRENT PROTECTORS								
RATED VOLTAGE VRMS	MAX. VOLTAGE VRMS	HOLD (I <sub>H</sub> ) CURRENT mA	TRIP (I <sub>T</sub> ) CURRENT mA	MAX. CURRENT A	RES R <sub>25</sub> Ohms	SWITCH TEMP °C	D MAX. mm	VISHAY CERA-MITE PART NUMBER
12	15	130	260	1.1	13	120	5.5	307C1455
12	15	170	340	2.4	6	105	8	307C1308
12	15	600	1200	10	1.2	105	16	307C1311
24	30	130	260	2.3	10	105	8	307C1315
24	30	175	350	3.4	6	105	9.5	307C1429
24	30	600	1200	11	1.3	105	17.5	307C1318
50	60	60	120	0.8	50	105	6.5	307C1321
50	60	120	240	2	12	105	8	307C1323
50	60	150	300	2.6	10	105	9.5	307C1548
50	60	325	650	10	3.5	105	14.5	307C1325
50	60	475	950	12	2	105	17.5	307C1326
120	140	60	120	0.6	50	105	6.5	307C1329
120	140	85	170	0.8	30	105	8	307C1330
120	140	95	190	1.5	39	105	11	307C1302
120	140	115	230	2	27	105	12.5	307C1303
120	140	105	210	1	20	105	9.5	307C1331
120	140	350	700	5	4.5	105	19	307C1333
240	375	20	40	0.2	600	105	6.5	307C1335
240	340	28	56	0.3	300	105	6.5	307C1336
240	310	31	62	0.33	240	105	6.5	307C1337
240	265	34	68	0.34	200	105	6.5	307C1338
240	265	40	80	0.45	125	105	6.5	307C1340
240	320	45	90	0.4	150	105	9.5	307C1339
240	320	55	110	0.5	100	105	11	307C1341
240	265	65	130	0.6	70	105	9.5	307C1342
240	265	90	180	1	45	105	11	307C1343
		Note 1		Note 2		Note 3		

## GENERAL PURPOSE PTC CURRENT LIMITERS

- Designed as resettable current limiters, PTC thermistors offer an alternative to conventional overcurrent protection devices such as fuses or circuit breakers.
- A wide variety of sizes and current ranges are available for many electronic, industrial and automotive applications. Both standard parts and custom designs are offered.

Fig P-13

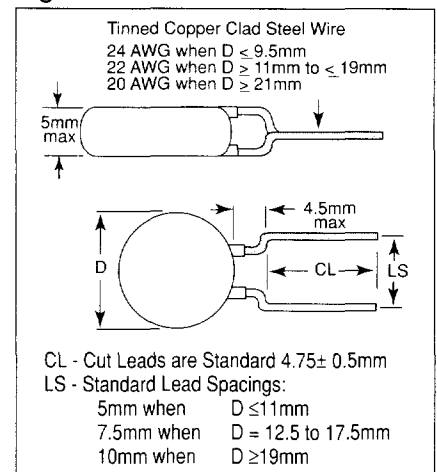

## CUSTOM CURRENT LIMITER GUIDELINES

Table 6

### RANGE CHART FOR CUSTOM WIRE LEADED DESIGN

MAX. D (mm)	DESIGN LIMITS (APPROX.)		
	V <sub>RMS</sub>	I <sub>HOLD</sub>	OHMS
5.5	600	5 mA	2000
	15	150 mA	13
6.5	600	7 mA	1200
	15	200 mA	8
8	600	10 mA	850
	15	275 mA	6
9.5	600	13 mA	500
	15	350 mA	4
11	600	20 mA	350
	15	450 mA	2.5
12.5	600	22 mA	250
	15	500 mA	2.0
14.5	600	30 mA	200
	15	650 mA	1.5
16	600	35 mA	150
	15	800 mA	1.2

MAX. D (mm)	DESIGN LIMITS (APPROX.)		
	V <sub>RMS</sub>	I <sub>HOLD</sub>	OHMS
17.5	600	40 mA	125
	15	950 mA	0.8
19	600	45 mA	100
	15	1.1 A	0.7
21	600	55 mA	80
	15	1.2 A	0.6
22.5	600	60 mA	70
	15	1.3 A	0.5
23.5	600	70 mA	60
	15	1.4 A	0.45
25	600	80 mA	50
	15	1.5 A	0.4

Resistance is proportional to voltage and inversely proportional to hold current (I<sub>H</sub>)

Conformal coating adds 1.5mm

## APPLICATION CONSIDERATIONS:

- PTC current limiters are intended for service on telecom systems, automobiles, or the secondary of control transformers or in similar applications where energy available is limited by source impedance. They are not intended for application on AC line voltages where source energy may be high and source impedance low.
- Fuses and circuit breakers result in total circuit isolation after tripping. PTC thermistors provide a current limiting function by switching to a high resistance mode. Safety consideration must be given to the potential shock hazard caused by the steady state leakage current and voltage potential remaining in the circuit.
- Wire leaded PTC current limiting thermistors are intended for applications which expect a limited number of tripping operations. Actual life is a function of operating parameters. For high duty cycle applications, ceramic PTC pellets mounted in spring contact mechanical housings are preferred.
- Wire size, wire type and coating material can be used to precisely tailor required operating characteristics.
- Options Include: Tape & Reel; Wire Forms; Lead Spacings.