

Inductors

Variable, Subminiature, Shielded

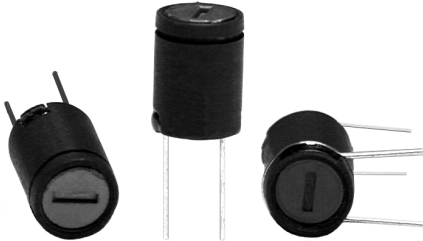

FEATURES

- Classification is Grade 3, Class A.
- Subminiature shielded adjustable inductor.
- High Q values.
- Vertical or horizontal mounting.
- Inductance range is 0.10 μ H to 1000 μ H.
- 0.300" [7.62mm] diameter by 0.400" [10.16mm] length.
- Printed board mounting facilitated by 0.200" [5.08mm] grid spacing.
- Unit has shield construction to allow maximum density packaging.
- Accommodates close inductance adjustments in high density circuits that demand exceptional stability and high "Q" in the smallest size available.

ELECTRICAL SPECIFICATIONS

Adjustable Inductance Range: Tunable range; $\pm 5\%$ for 0.10 μ H to 1 μ H. $\pm 10\%$ for 1.2 μ H to 1000 μ H.

Dielectric Strength: 840VRMS at sea level.

Working Voltage: 300VDC.

Maximum Current: Based on temperature rise not to exceed 15°C at + 90°C ambient.

Incremental Current: The DC current required to cause a five percent reduction in the nominal inductance value.

Operating Temperature: - 55°C to + 105°C.

MECHANICAL SPECIFICATIONS

Tuning Tool: Use Number WVL-T or equal.

Torque: 0.40 to 6 inch-ounces.

Terminal Pull: 3 pounds.

DENSITY SPECIFICATIONS

Weight: 1.5 grams maximum.

Shielding: 3% coupling maximum when two units are tested side by side.

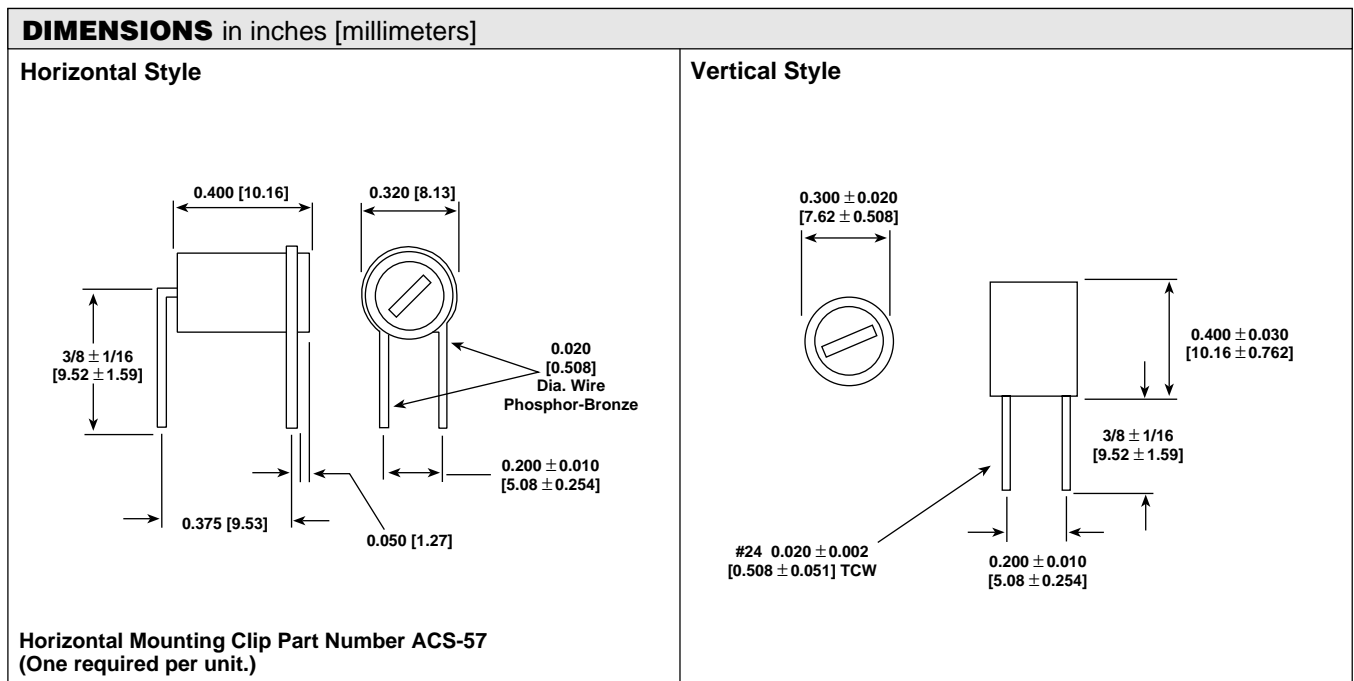

STANDARD ELECTRICAL SPECIFICATIONS

MODEL	INDUCTANCE NOM. (μ H)	TUNABLE RANGE	Q MINIMUM	TEST FREQUENCY (MHz)	SELF-RESONANT FREQ. MIN. (MHz)	DCR MAXIMUM (Ohms)	RATED DC CURRENT (mA)	INCREMENTAL CURRENT (mA)
WVL	0.10	$\pm 5\%$	56	25	200	0.030	1510	—
WVL	0.12	$\pm 5\%$	56	25	200	0.030	1450	—
WVL	0.15	$\pm 5\%$	56	25	200	0.030	1400	—
WVL	0.18	$\pm 5\%$	56	25	200	0.035	1370	—
WVL	0.22	$\pm 5\%$	56	25	200	0.038	1340	—
WVL	0.27	$\pm 5\%$	64	25	200	0.040	1300	—
WVL	0.33	$\pm 5\%$	64	25	200	0.040	1260	—
WVL	0.39	$\pm 5\%$	64	25	200	0.045	1240	—
WVL	0.47	$\pm 5\%$	64	25	184	0.045	1200	—
WVL	0.56	$\pm 5\%$	64	25	176	0.050	1160	—
WVL	0.68	$\pm 5\%$	64	25	150	0.055	1100	—
WVL	0.82	$\pm 5\%$	68	25	144	0.060	1040	—
WVL	1.0	$\pm 5\%$	68	25	128	0.070	986	—
WVL	1.2	$\pm 10\%$	72	7.9	136	0.085	968	—
WVL	1.5	$\pm 10\%$	80	7.9	124	0.100	893	—
WVL	1.8	$\pm 10\%$	92	7.9	108	0.110	853	—
WVL	2.2	$\pm 10\%$	88	7.9	96	0.120	817	—
WVL	2.7	$\pm 10\%$	88	7.9	83	0.125	800	—
WVL	3.3	$\pm 10\%$	77	7.9	74	0.165	696	—
WVL	3.9	$\pm 10\%$	72	7.9	70	0.180	659	—
WVL	4.7	$\pm 10\%$	76	7.9	63	0.245	571	—
WVL	5.6	$\pm 10\%$	76	7.9	58	0.265	550	—
WVL	6.8	$\pm 10\%$	68	7.9	50	0.330	493	—
WVL	8.2	$\pm 10\%$	76	7.9	48	0.460	417	—
WVL	10	$\pm 10\%$	72	7.9	43	0.640	359	—
WVL	12	$\pm 10\%$	96	2.5	30	0.800	316	—
WVL	15	$\pm 10\%$	96	2.5	23	0.865	301	—
WVL	18	$\pm 10\%$	92	2.5	19	0.940	292	—
WVL	22	$\pm 10\%$	100	2.5	17	1.03	267	—
WVL	27	$\pm 10\%$	92	2.5	16	1.18	243	—
WVL	33	$\pm 10\%$	96	2.5	15	1.30	231	—
WVL	39	$\pm 10\%$	96	2.5	14	1.41	223	—
WVL	47	$\pm 10\%$	88	2.5	12	1.61	203	—
WVL	56	$\pm 10\%$	92	2.5	11	2.08	191	—
WVL	68	$\pm 10\%$	84	2.5	10	2.20	185	—
WVL	82	$\pm 10\%$	84	2.5	9	2.42	174	—
WVL	100	$\pm 10\%$	76	2.5	8.4	2.15	333	333
WVL	120	$\pm 10\%$	76	0.79	4.5	2.38	316	190
WVL	150	$\pm 10\%$	72	0.79	4.0	2.52	306	175
WVL	180	$\pm 10\%$	76	0.79	3.9	2.88	288	150
WVL	220	$\pm 10\%$	76	0.79	3.7	3.18	273	125
WVL	270	$\pm 10\%$	80	0.79	3.4	3.50	260	120
WVL	330	$\pm 10\%$	80	0.79	2.8	4.80	222	110
WVL	390	$\pm 10\%$	80	0.79	2.7	5.44	209	105
WVL	470	$\pm 10\%$	80	0.79	2.6	5.90	201	100
WVL	560	$\pm 10\%$	76	0.79	2.3	6.30	194	90
WVL	680	$\pm 10\%$	80	0.79	2.2	7.20	181	80
WVL	820	$\pm 10\%$	72	0.79	2.0	8	172	70
WVL	1000	$\pm 10\%$	80	0.79	1.9	12	141	65

MARKING

— Manufacturer data printed

ORDERING INFORMATIONWVL
MODEL0.10 μ H
INDUCTANCE
VALUE $\pm 5\%$
TUNABLE
RANGE

For horizontal mounting use mounting clip Number ACS-57 or order with prefix H (i.e. H WVL .10).