

---

# HD74AC259

8-bit Addressable Latch

# HITACHI

ADE-205-385 (Z)  
1st. Edition  
Sep. 2000

---

## Description

The HD74AC259 is a high-speed 8-bit addressable latch designed for general purpose storage applications in digital systems. It is a multifunctional device capable of storing single line data in eight addressable latches, and also a 1-of-8 decoder and demultiplexer with active HIGH outputs. The device also incorporates an active LOW Common Clear for resetting all latches, as well as an active LOW Enable.

## Features

- Serial-to-Parallel Conversion
- Eight Bits of Storage with Output of Each Bit Available
- Random (Addressable) Data Entry
- Active High Demultiplexing or Decoding Capability
- Easily Expandable
- Common Clear
- Outputs Source/Sink 24 mA

# HD74AC259

## Pin Arrangement

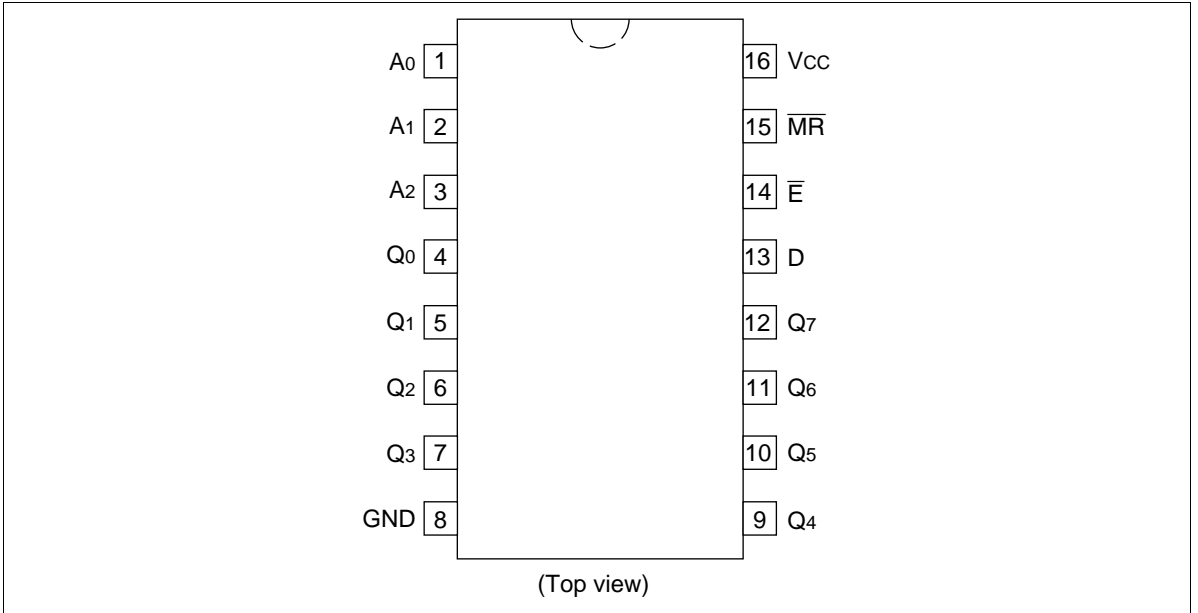

## Logic Symbol

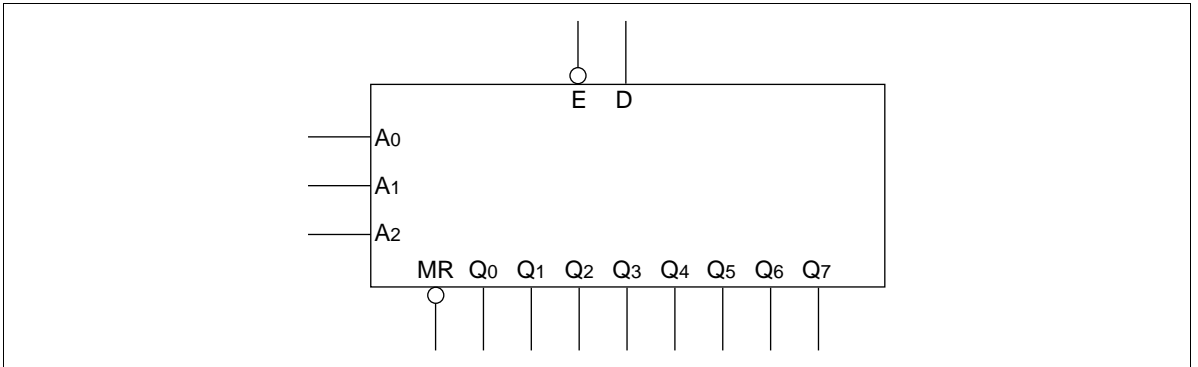

## Pin Names

- A<sub>0</sub> – A<sub>2</sub> Address Inputs
- D Data Inputs
- $\bar{E}$  Enable Input (Active LOW)
- $\overline{MR}$  Master Reset (Active LOW)
- Q<sub>0</sub> – Q<sub>7</sub> Latch Outputs

**HITACHI**

Logic Diagram

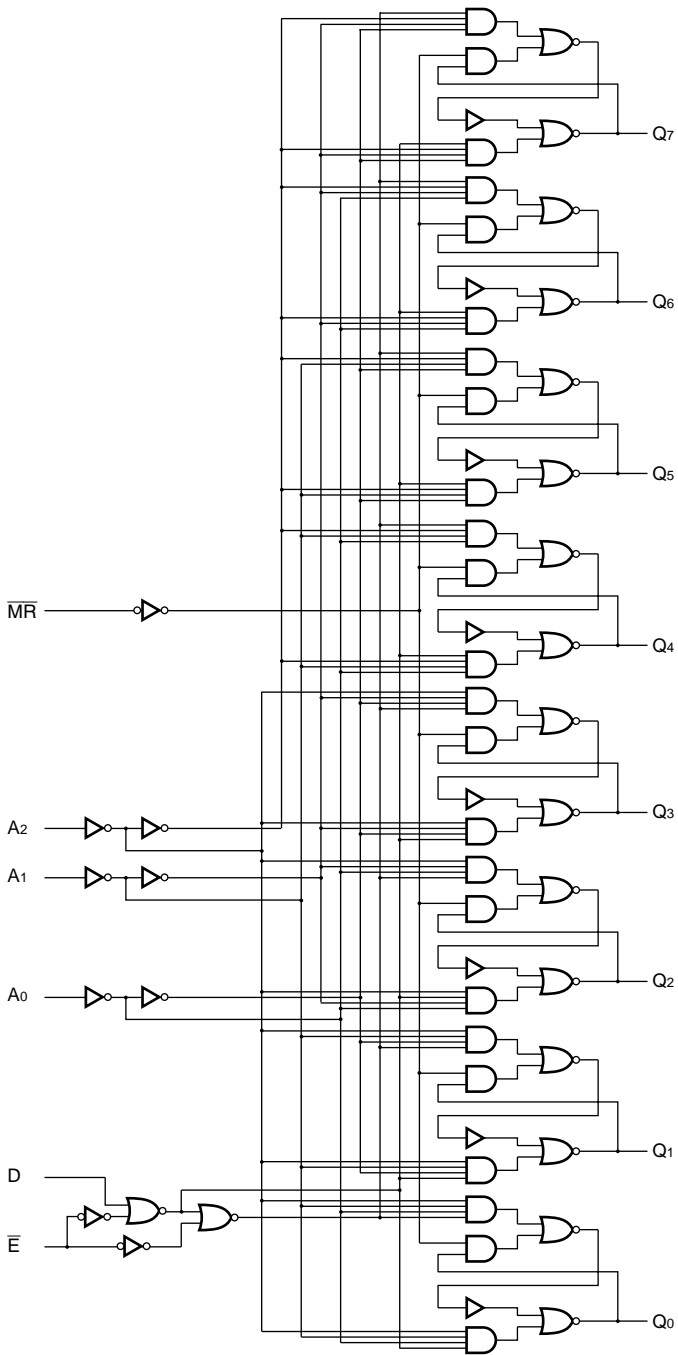

## Function Table

Operating Mode	Inputs						Outputs							
	MR	$\bar{E}$	D	A <sub>0</sub>	A <sub>1</sub>	A <sub>2</sub>	Q <sub>0</sub>	Q <sub>1</sub>	Q <sub>2</sub>	Q <sub>3</sub>	Q <sub>4</sub>	Q <sub>5</sub>	Q <sub>6</sub>	Q <sub>7</sub>
Master reset	L	H	X	X	X	X	L	L	L	L	L	L	L	L
Demultiplex	L	L	d	L	L	L	Q = d	L	L	L	L	L	L	L
(Active HIGH)	L	L	d	H	L	L	L	Q = d	L	L	L	L	L	L
Decoder when	L	L	d	L	H	L	L	L	Q = d	L	L	L	L	L
D = H)	L	L	d	H	H	L	L	L	L	Q = d	L	L	L	L
	L	L	d	L	L	H	L	L	L	L	Q = d	L	L	L
	L	L	d	H	L	H	L	L	L	L	L	Q = d	L	L
	L	L	d	L	H	H	L	L	L	L	L	L	Q = d	L
	L	L	d	H	H	H	L	L	L	L	L	L	L	Q = d
Store (Do nothing)	H	H	X	X	X	X	q <sub>0</sub>	q <sub>1</sub>	q <sub>2</sub>	q <sub>3</sub>	q <sub>4</sub>	q <sub>5</sub>	q <sub>6</sub>	q <sub>7</sub>
Addressable latch	H	L	d	L	L	L	Q = d	q <sub>1</sub>	q <sub>2</sub>	q <sub>3</sub>	q <sub>4</sub>	q <sub>5</sub>	q <sub>6</sub>	q <sub>7</sub>
	H	L	d	H	L	L	q <sub>0</sub>	Q = d	q <sub>2</sub>	q <sub>3</sub>	q <sub>4</sub>	q <sub>5</sub>	q <sub>6</sub>	q <sub>7</sub>
	H	L	d	L	H	L	q <sub>0</sub>	q <sub>1</sub>	Q = d	q <sub>3</sub>	q <sub>4</sub>	q <sub>5</sub>	q <sub>6</sub>	q <sub>7</sub>
	H	L	d	H	H	L	q <sub>0</sub>	q <sub>1</sub>	q <sub>2</sub>	Q = d	q <sub>4</sub>	q <sub>5</sub>	q <sub>6</sub>	q <sub>7</sub>
	H	L	d	L	L	H	q <sub>0</sub>	q <sub>1</sub>	q <sub>2</sub>	q <sub>3</sub>	Q = d	q <sub>5</sub>	q <sub>6</sub>	q <sub>7</sub>
	H	L	d	H	L	H	q <sub>0</sub>	q <sub>1</sub>	q <sub>2</sub>	q <sub>3</sub>	q <sub>4</sub>	Q = d	q <sub>6</sub>	q <sub>7</sub>
	H	L	d	L	H	H	q <sub>0</sub>	q <sub>1</sub>	q <sub>2</sub>	q <sub>3</sub>	q <sub>4</sub>	q <sub>5</sub>	Q = d	q <sub>7</sub>
	H	L	d	H	H	H	q <sub>0</sub>	q <sub>1</sub>	q <sub>2</sub>	q <sub>3</sub>	q <sub>4</sub>	q <sub>5</sub>	q <sub>6</sub>	Q = d

H : High Voltage Level

L : Low Voltage Level

X : Immaterial

d : High or Low data one setup time prior to the Low-to-High Enable transition.

q : Lower case letters indicate the state of the referenced output established during the last cycle in which it was addressed or cleared.

## DC Characteristics (unless otherwise specified)

Item	Symbol	Max	Unit	Condition
Maximum quiescent supply current	I <sub>cc</sub>	80	μA	V <sub>IN</sub> = V <sub>CC</sub> or ground, V <sub>CC</sub> = 5.5 V, Ta = Worst case
Maximum quiescent supply current	I <sub>cc</sub>	8.0	μA	V <sub>IN</sub> = V <sub>CC</sub> or ground, V <sub>CC</sub> = 5.5 V, Ta = 25°C

## AC Characteristics: HD74AC259

Item	Symbol	V <sub>CC</sub> (V)*1	Ta = +25°C C <sub>L</sub> = 50 pF			Ta = -40°C to +85°C C <sub>L</sub> = 50 pF		Unit
			Min	Typ	Max	Min	Max	
Maximum clock frequency	f <sub>max</sub>	3.3	65	—	—	60	—	MHz
		5.0	110	—	—	95	—	
Propagation delay M $\bar{R}$ to Q <sub>n</sub>	t <sub>PHL</sub>	3.3	1.0	8.5	14.5	1.0	16.5	ns
		5.0	1.0	6.5	9.0	1.0	10.5	
Propagation delay D <sub>n</sub> to Q <sub>n</sub>	t <sub>PLH</sub>	3.3	1.0	7.0	10.5	1.0	12.0	ns
		5.0	1.0	5.5	7.5	1.0	8.5	
Propagation delay D <sub>n</sub> to Q <sub>n</sub>	t <sub>PHL</sub>	3.3	1.0	7.0	10.5	1.0	12.0	ns
		5.0	1.0	5.5	7.5	1.0	8.5	
Propagaion delay A <sub>n</sub> to Q <sub>n</sub>	t <sub>PLH</sub>	3.3	1.0	11.5	18.5	1.0	21.5	ns
		5.0	1.0	8.0	11.5	1.0	14.0	
Propagation delay A <sub>n</sub> to Q <sub>n</sub>	t <sub>PHL</sub>	3.3	1.0	11.5	18.5	1.0	21.0	ns
		5.0	1.0	8.0	11.5	1.0	13.5	
Propagation delay E $\bar{}$ to Q	t <sub>PLH</sub>	3.3	1.0	9.0	15.0	1.0	17.0	ns
		5.0	1.0	6.5	9.0	1.0	10.5	
Propagation delay E $\bar{}$ to Q <sub>n</sub>	t <sub>PHL</sub>	3.3	1.0	9.0	14.0	1.0	16.0	ns
		5.0	1.0	6.5	8.5	1.0	10.0	

Note: 1. Voltage Range 3.3 is 3.3 V ± 0.3 V  
Voltage Range 5.0 is 5.0 V ± 0.5 V

**AC Operating Requirements: HD74AC259**

Item	Symbol	$V_{CC}$ (V)*1	$T_a = +25^\circ\text{C}$	$T_a = -40^\circ\text{C}$		Unit
			Typ	to $+85^\circ\text{C}$		
			$C_L = 50\text{ pF}$	$C_L = 50\text{ pF}$		
Setup time, HIGH or LOW	$t_{su}$	3.3	1.0	3.5	3.5	ns
D to $\bar{E}$		5.0	0.0	3.0	3.0	
Hold time, HIGH or LOW	$t_h$	3.3	0.5	2.0	2.0	ns
D to $\bar{E}$		5.0	0.5	2.0	2.0	
Setup time, HIGH or LOW	$t_{su}$	3.3	1.0	6.0	7.0	ns
$A_n$ to $\bar{E}$		5.0	0.0	4.5	5.0	
Hold time, HIGH or LOW	$t_h$	3.3	-3.0	0.0	0.0	ns
$A_n$ to $\bar{E}$		5.0	-1.0	0.0	0.0	
Pulse width	$t_w$	3.3	3.0	5.5	7.0	ns
		5.0	3.0	4.5	5.0	

Note: 1. Voltage Range 3.3 is  $3.3\text{ V} \pm 0.3\text{ V}$   
Voltage Range 5.0 is  $5.0\text{ V} \pm 0.5\text{ V}$

**Capacitance**

Item	Symbol	Typ	Unit	Condition
Input capacitance	$C_{IN}$	4.5	pF	$V_{CC} = 5.5\text{ V}$
Power dissipation capacitance	$C_{PD}$	35	pF	$V_{CC} = 5.0\text{ V}$

Package Dimensions

Unit: mm

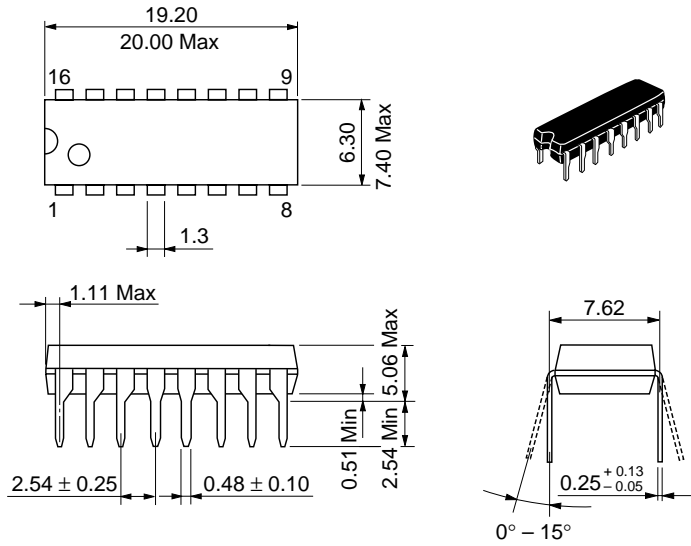

Hitachi Code	DP-16
JEDEC	Conforms
EIAJ	Conforms
Mass (reference value)	1.07 g

Unit: mm

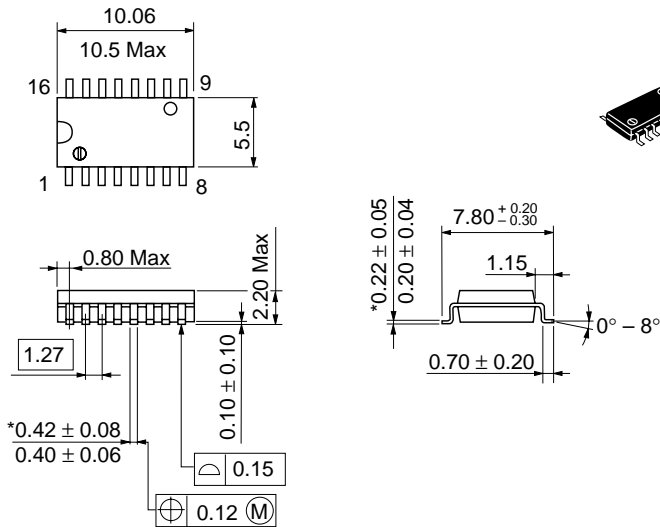

Hitachi Code	FP-16DA
JEDEC	—
EIAJ	Conforms
Mass (reference value)	0.24 g

\*Dimension including the plating thickness  
Base material dimension



## Cautions

1. Hitachi neither warrants nor grants licenses of any rights of Hitachi's or any third party's patent, copyright, trademark, or other intellectual property rights for information contained in this document. Hitachi bears no responsibility for problems that may arise with third party's rights, including intellectual property rights, in connection with use of the information contained in this document.
2. Products and product specifications may be subject to change without notice. Confirm that you have received the latest product standards or specifications before final design, purchase or use.
3. Hitachi makes every attempt to ensure that its products are of high quality and reliability. However, contact Hitachi's sales office before using the product in an application that demands especially high quality and reliability or where its failure or malfunction may directly threaten human life or cause risk of bodily injury, such as aerospace, aeronautics, nuclear power, combustion control, transportation, traffic, safety equipment or medical equipment for life support.
4. Design your application so that the product is used within the ranges guaranteed by Hitachi particularly for maximum rating, operating supply voltage range, heat radiation characteristics, installation conditions and other characteristics. Hitachi bears no responsibility for failure or damage when used beyond the guaranteed ranges. Even within the guaranteed ranges, consider normally foreseeable failure rates or failure modes in semiconductor devices and employ systemic measures such as fail-safes, so that the equipment incorporating Hitachi product does not cause bodily injury, fire or other consequential damage due to operation of the Hitachi product.
5. This product is not designed to be radiation resistant.
6. No one is permitted to reproduce or duplicate, in any form, the whole or part of this document without written approval from Hitachi.
7. Contact Hitachi's sales office for any questions regarding this document or Hitachi semiconductor products.

# HITACHI

## Hitachi, Ltd.

Semiconductor & Integrated Circuits.  
Nippon Bldg., 2-6-2, Ohte-machi, Chiyoda-ku, Tokyo 100-0004, Japan  
Tel: Tokyo (03) 3270-2111 Fax: (03) 3270-5109

URL	North America	: <a href="http://semiconductor.hitachi.com/">http://semiconductor.hitachi.com/</a>
	Europe	: <a href="http://www.hitachi-eu.com/hel/ecg">http://www.hitachi-eu.com/hel/ecg</a>
	Asia	: <a href="http://sicapac.hitachi-asia.com">http://sicapac.hitachi-asia.com</a>
	Japan	: <a href="http://www.hitachi.co.jp/Sicd/indx.htm">http://www.hitachi.co.jp/Sicd/indx.htm</a>

### For further information write to:

Hitachi Semiconductor  
(America) Inc.  
179 East Tasman Drive,  
San Jose, CA 95134  
Tel: <1> (408) 433-1990  
Fax: <1> (408) 433-0223

Hitachi Europe GmbH  
Electronic Components Group  
Dornacher Straße 3  
D-85622 Feldkirchen, Munich  
Germany  
Tel: <49> (89) 9 9180-0  
Fax: <49> (89) 9 29 30 00

Hitachi Europe Ltd.  
Electronic Components Group.  
Whitebrook Park  
Lower Cookham Road  
Maidenhead  
Berkshire SL6 8YA, United Kingdom  
Tel: <44> (1628) 585000  
Fax: <44> (1628) 585160

Hitachi Asia Ltd.  
Hitachi Tower  
16 Collyer Quay #20-00,  
Singapore 049318  
Tel: <65>-538-6533/538-8577  
Fax : <65>-538-6933/538-3877  
URL : <http://www.hitachi.com.sg>

Hitachi Asia Ltd.  
(Taipei Branch Office)  
4/F, No. 167, Tun Hwa North Road,  
Hung-Kuo Building,  
Taipei (105), Taiwan  
Tel: <886>-(2)-2718-3666  
Fax : <886>-(2)-2718-8180  
Telex : 23222 HAS-TP  
URL : <http://www.hitachi.com.tw>

Hitachi Asia (Hong Kong) Ltd.  
Group III (Electronic Components)  
7/F., North Tower,  
World Finance Centre,  
Harbour City, Canton Road  
Tsim Sha Tsui, Kowloon,  
Hong Kong  
Tel : <852>-(2)-735-9218  
Fax : <852>-(2)-730-0281  
URL : <http://www.hitachi.com.hk>

Copyright © Hitachi, Ltd., 2000. All rights reserved. Printed in Japan.  
Colophon 2.0

## HITACHI