

# X9530

## Temperature Compensated Laser Diode Controller

### FEATURES

- **Compatible with Popular Fiber Optic Module Specifications such as Xenpak, SFF, SFP, and GBIC**
- **Package**
  - 14 Pin TSSOP
  - 15 Lead 2.7 x 3.5mm CSP (Chip-Scale Package)
- **Two Programmable Current Generators**
  - $\pm 1.6$  mA max.
  - 8-bit (256 Step) Resolution
- **Integrated 6 bit A/D Converter**
- **Temperature Compensation**
  - Internal or External Sensor
  - $-40^{\circ}\text{C}$  to  $+100^{\circ}\text{C}$  Range
  - $2.2^{\circ}\text{C}$  / step resolution
  - EEPROM Look-up Tables
- **Hot Pluggable**
- **2176-bit EEPROM**
  - 17 Pages
  - 16 Bytes per Page
- **Write Protection Circuitry**
  - Xicor BlockLock™
  - Logic Controlled Protection
  - 2-wire Bus with 3 Slave Address Bits
- **3 V to 5.5 V, Single Supply Operation**

### DESCRIPTION

The X9530 is a highly integrated laser diode bias controller which incorporates two digitally controlled Programmable Current Generators, temperature compensation with dedicated look-up tables, and supplementary EEPROM array. All functions of the device are controlled via a 2-wire digital serial interface.

Two temperature compensated Programmable Current Generators, vary the output current with temperature according to the contents of the associated nonvolatile look-up table. The look-up table may be programmed with arbitrary data by the user, via the 2-wire serial port, and either an internal or external temperature sensor may be used to control the output current response. These temperature compensated programmable currents maybe used to control the modulation current and the bias current of a laser diode.

The integrated General Purpose EEPROM is included for product data storage and can be used for transceiver module information storage in laser diode applications.

### LASER DIODE BIAS CONTROL APPLICATIONS

- **SONET and SDH Transmission Systems**
- **1G and 10G Ethernet, and Fibre Channel Laser Diode Driver Circuits**

### TYPICAL APPLICATION

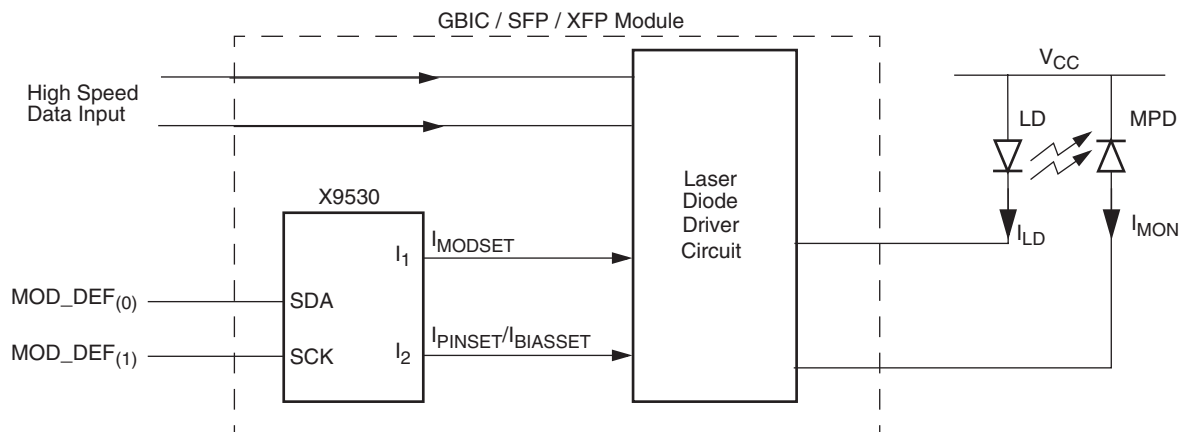

# X9530

## BLOCK DIAGRAM

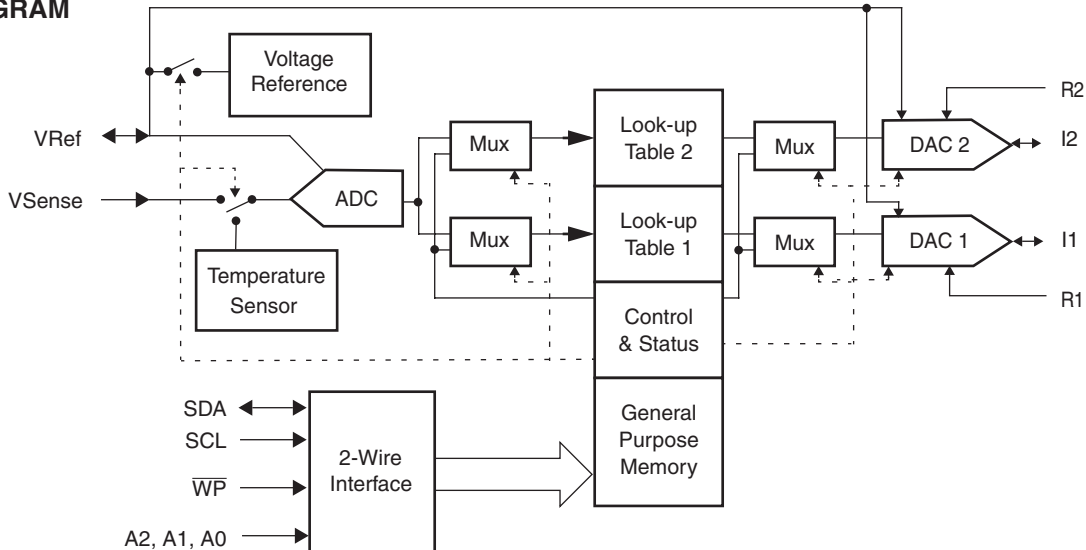

## PIN CONFIGURATION

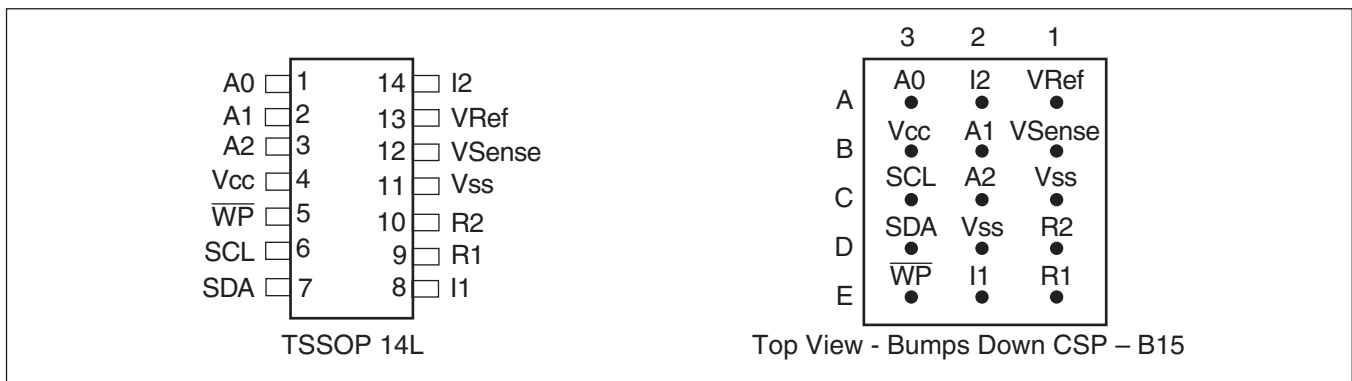

## DEVICE DESCRIPTION

The X9530 combines two Programmable Current Generators, and integrated EEPROM with Block Lock™ protection, in one package. The Programmable Current Generators are ideal for use in fiber optic Modulation Current require temperature control. The combination of the X9530 functionality and Xicor's Chip-Scale package lowers system cost, increases reliability, and reduces board space requirements.

Two on-chip Programmable Current Generators may be independently programmed to either sink or source current. The maximum current generated is determined by using an externally connected programming resistor, or by selecting one of three predefined values. Both current generators have a maximum output of  $\pm 1.6$  mA, and may be controlled to an absolute resolution of 0.39% (256 steps / 8 bit).

Both current generators may be driven using an on-board temperature sensor, an external sensor, or Control Registers. The internal temperature sensor operates over a very broad temperature range ( $-40^{\circ}\text{C}$  to  $+100^{\circ}\text{C}$ ). The sensor output (internal or external) drives a 6-bit A/D converter, whose output selects one of 64 bytes from each nonvolatile look-up table (LUT).

The contents of the selected LUT row (8-bit wide) drives the input of an 8-bit D/A converter, which generates the output current.

All control and setup parameters of the X9530, including the look-up tables, are programmable via the 2-wire serial port.

The general purpose memory portion of the device is a CMOS serial EEPROM array with Xicor's Block Lock™ protection. This memory may be used to store fiber optic module manufacturing data, serial numbers, or various other system parameters.

## X9530

The EEPROM array is internally organized as 272 x 8 bits with 16-Byte pages, and utilizes Xicor's proprietary Direct Write™ cells, providing a minimum endurance of 100,000 Page Write cycles and a minimum data retention of 100 years.

### PIN ASSIGNMENTS

TSSOP Pin	CSP Pin	Pin Name	Pin Description
1	A3	A0	<b>Device Address Select Pin 0.</b> This pin determines the LSB of the device address required to communicate using the 2-wire interface. The A0 pin has an on-chip pull-down resistor.
2	B2	A1	<b>Device Address Select Pin 1.</b> This pin determines the intermediate bit of the device address required to communicate using the 2-wire interface. The A1 pin has an on-chip pull-down resistor.
3	C2	A2	<b>Device Address Select Pin 2.</b> This pin determines the MSB of the device address required to communicate using the 2-wire interface. The A2 pin has an on-chip pull-down resistor.
4	B3	Vcc	<b>Supply Voltage.</b>
5	E3	$\overline{WP}$	<b>Write Protect Control Pin.</b> This pin is a CMOS compatible input. When LOW, Write Protection is enabled preventing any "Write" operation. When HIGH, various areas of the memory can be protected using the Block Lock bits BL1 and BL0. The $\overline{WP}$ pin has an on-chip pull-down resistor, which enables the Write Protection when this pin is left floating.
6	C3	SCL	<b>Serial Clock.</b> This is a TTL compatible input pin. This input is the 2-wire interface clock controlling data input and output at the SDA pin.
7	D3	SDA	<b>Serial Data.</b> This pin is the 2-wire interface data into or out of the device. It is TTL compatible when used as an input, and it is Open Drain when used as an output. This pin requires an external pull up resistor.
8	E2	I1	<b>Current Generator 1 Output.</b> This pin sinks or sources current. The magnitude and direction of the current is fully programmable and adaptive. The resolution is 8 bits.
9	E1	R1	<b>Current Programming Resistor 1.</b> A resistor between this pin and Vss can set the maximum output current available at pin I1. If no resistor is used, the maximum current must be selected using control register bits.
10	D1	R2	<b>Current Programming Resistor 2.</b> A resistor between this pin and Vss can set the maximum output current available at pin I2. If no resistor is used, the maximum current must be selected using control register bits.
11	C1, D2	Vss	<b>Ground.</b>
12	B1	VSense	<b>Sensor Voltage Input.</b> This voltage input may be used to drive the input of the on-chip A/D converter.
13	A1	VRef	<b>Reference Voltage Input or Output.</b> This pin can be configured as either an Input or an Output. As an Input, the voltage at this pin is provided by an external source. As an Output, the voltage at this pin is a buffered output voltage of the on-chip bandgap reference circuit. In both cases, the voltage at this pin is the reference for the A/D converter and the two D/A converters.
14	A2	I2	<b>Current Generator 2 Output.</b> This pin sinks or sources current. The magnitude and direction of the current is fully programmable and adaptive. The resolution is 8 bits.

## PRINCIPLES OF OPERATION

### CONTROL AND STATUS REGISTERS

The Control and Status Registers provide the user with a mechanism for changing and reading the value of various parameters of the X9530. The X9530 contains seven Control, one Status, and several Reserved registers, each being one Byte wide (See Figure 1). The Control registers 0 through 6 are located at memory addresses 80h through 86h respectively. The Status register is at memory address 87h, and the Reserved registers at memory address 88h through 8Fh.

All bits in Control register 6 always power up to the logic state “0”. All bits in Control registers 0 through 5 power up to the logic state value kept in their corresponding nonvolatile memory cells. The nonvolatile bits of a register retain their stored values even when the X9530 is powered down, then powered back up. The nonvolatile bits in Control 0 through Control 5 registers are all preprogrammed to the logic state “0” at the factory.

Bits indicated as “Reserved” are ignored when read, and must be written as “0”, if any Write operation is performed to their registers.

A detailed description of the function of each of the Control and Status register bits follows:

#### Control Register 0

This register is accessed by performing a Read or Write operation to address 80h of memory.

#### BL1, BL0: BLOCK LOCK PROTECTION BITS (NON-VOLATILE)

These two bits are used to inhibit any write operation to certain addresses within the memory array. The protected region of memory is determined by the values of the two bits as shown in the table below:

BL1	BL0	Protected Addresses (Size)	Partition of array locked
0	0	None (Default)	None (Default)
0	1	00h to 7Fh (128 bytes)	GPM
1	0	00h to 7Fh and 90h to CFh (192 bytes)	GPM, LUT1
1	1	00h to 7Fh and 90h to 10Fh (256 bytes)	GPM, LUT1, LUT2

If the user attempts to perform a write operation to a protected region of memory, the operation is aborted without changing any data in the array.

Notice that if the Write Protect ( $\overline{WP}$ ) input pin of the X9530 is active (LOW), then any write operation to the memory is inhibited, irrespective of the Block Lock bit settings.

#### VRM: VOLTAGE REFERENCE PIN MODE (NON-VOLATILE)

The VRM bit configures the Voltage Reference pin (VRef) as either an input or an output. When the VRM bit is set to “0” (default), the voltage at pin VRef is an output from the X9530’s internal voltage reference. When the VRM bit is set to “1”, the voltage reference for the VRef pin is external. See Figure 2.

#### ADCIN: A/D CONVERTER INPUT SELECT (NON-VOLATILE)

The ADCIN bit selects the input of the on-chip A/D converter. When the ADCIN bit is set to “0” (default), the output of the on-chip temperature sensor is the input to the A/D converter. When the ADCIN bit is set to “1”, the input to the A/D converter is the voltage at the VSense pin. See Figure 4.

#### ADCFILTOff: ADC FILTERING CONTROL (NON-VOLATILE)

When this bit is “1”, the status register at 87h is updated after every conversion of the ADC. When this bit is “0” (default), the status register is updated after four consecutive conversions with the same result.

#### NV1234: CONTROL REGISTERS 1, 2, 3, AND 4 VOLATILITY MODE SELECTION BIT (NON-VOLATILE)

When the NV1234 bit is set to “0” (default), bytes written to Control registers 1, 2, 3, and 4 are stored in volatile cells, and their content is lost when the X9530 is powered down. When the NV1234 bit is set to “1”, bytes written to Control registers 1, 2, 3, and 4 are stored in both volatile and nonvolatile cells, and their value doesn’t change when the X9530 is powered down and powered back up. See “Writing to Control Registers” on page 17.

#### I1DS: CURRENT GENERATOR 1 DIRECTION SELECT BIT (NON-VOLATILE)

The I1DS bit sets the polarity of Current Generator 1, DAC1. When this bit is set to “0” (default), the Current Generator 1 of the X9530 is configured as a Current Source. Current Generator 1 is configured as a Current Sink when the I1DS bit is set to “1”. See Figure 5.

Figure 1. Control and Status Register Format

Byte Address	MSB								LSB	Register Name
	7	6	5	4	3	2	1	0		
80h Non-Volatile	I2DS	I1DS	NV1234	ADCfiltOff	ADCIN	VRM	BL1	BL0	Control 0	
	I1 and I2 Direction 0: Source 1: Sink		Control 1, 2, 3, 4 Volatility 0: Volatile 1: Non-volatile	ADC filtering 0: On 1: Off	ADC Input 0: Internal 1: External	Voltage Reference Mode 0: Internal 1: External	Block Lock 00: None Locked 01: GPM Locked 10: GPM, LUT1, Locked 11: GPM, LUT1, LUT2 Locked			
Direct Access to LUT1										
81h Volatile or Non-Volatile	Reserved	Reserved	L1DA5	L1DA4	L1DA3	L1DA2	L1DA1	L1DA0	Control 1	
Direct Access to LUT2										
82h Volatile or Non-Volatile	Reserved	Reserved	L2DA5	L2DA4	L2DA3	L2DA2	L2DA1	L2DA0	Control 2	
Direct Access to DAC1										
83h Volatile or Non-Volatile	D1DA7	D1DA6	D1DA5	D1DA4	D1DA3	D1DA2	D1DA1	D1DA0	Control 3	
Direct Access to DAC2										
84h Volatile or Non-Volatile	D2DA7	D2DA6	D2DA5	D2DA4	D2DA3	D2DA2	D2DA1	D2DA0	Control 4	
85h Non-Volatile	D2DAS	L2DAS	D1DAS	L1DAS	I2FSO1	I2FSO0	I1FSO1	I1FSO0	Control 5	
	Direct Access to DAC2 0: Disabled 1: Enabled	Direct Access to LUT2 0: Disabled 1: Enabled	Direct Access to DAC1 0: Disabled 1: Enabled	Direct Access to LUT1 0: Disabled 1: Enabled	R2 Selection 00: External 01: Low Internal 10: Middle Internal 11: High Internal		R1 Selection 00: External 01: Low Internal 10: Middle Internal 11: High Internal			
86h Volatile	WEL	Reserved	Reserved	Reserved	Reserved	Reserved	Reserved	Reserved	Control 6	
	Write Enable Latch 0: Write Disabled 1: Write Enabled									
ADC Output										
87h Volatile	AD5	AD4	AD3	AD2	AD1	AD0	Reserved	Reserved	Status	

Registers in byte addresses 88h through 8Fh are reserved.

# X9530

## I2DS: CURRENT GENERATOR 2 DIRECTION SELECT BIT (NON-VOLATILE)

The I2DS bit sets the polarity of Current Generator 2, DAC2. When this bit is set to “0” (default), the Current Generator 2 of the X9530 is configured as a Current Source. Current Generator 2 is configured as a Current Sink when the I2DS bit is set to “1”. See Figure 5.

### Control Register 1

This register is accessed by performing a Read or Write operation to address 81h of memory. This byte’s volatility is determined by bit NV1234 in Control register 0.

## L1DA5–L1DA0: LUT1 DIRECT ACCESS BITS

When bit L1DAS (bit 4 in Control register 5) is set to “1”, LUT1 is addressed by these six bits, and it is not addressed by the output of the on-chip A/D converter. When bit L1DAS is set to “0”, these six bits are ignored by the X9530. See Figure 7.

A value between 00h (00<sub>10</sub>) and 3Fh (63<sub>10</sub>) may be written to these register bits, to select the corresponding row in LUT1. The written value is added to the base address of LUT1 (90h).

### Control Register 2

This register is accessed by performing a read or write operation to address 82h of memory. This byte’s volatility is determined by bit NV1234 in Control register 0.

## L2DA5–L2DA0: LUT2 DIRECT ACCESS BITS

When bit L2DAS (bit 6 in Control register 5) is set to “1”, LUT2 is addressed by these six bits, and it is not addressed by the output of the on-chip A/D converter. When bit L2DAS is set to “0”, these six bits are ignored by the X9530. See Figure 7.

A value between 00h (00<sub>10</sub>) and 3Fh (63<sub>10</sub>) may be written to these register bits, to select the corresponding row in LUT2. The written value is added to the base address of LUT2 (D0h).

### Control Register 3

This register is accessed by performing a Read or Write operation to address 83h of memory. This byte’s volatility is determined by bit NV1234 in Control register 0.

## D1DA7–D1DA0: D/A 1 DIRECT ACCESS BITS

When bit D1DAS (bit 5 in Control register 5) is set to “1”, the input to the D/A converter 1 is the content of bits D1DA7–D1DA0, and it is not a row of LUT1. When bit D1DAS is set to “0” (default) these eight bits are ignored by the X9530. See Figure 6.

### Control Register 4

This register is accessed by performing a Read or Write operation to address 84h of memory. This byte’s volatility is determined by bit NV1234 in Control register 0.

## D2DA7–D2DA0: D/A 2 DIRECT ACCESS BITS

When bit D2DAS (bit 7 in Control register 5) is set to “1”, the input to the D/A converter 1 is the content of bits D2DA7–D2DA0, and it is not a row of LUT2. When bit D2DAS is set to “0” (default) these eight bits are ignored by the X9530. (See Figure 6).

### Control Register 5

This register is accessed by performing a Read or Write operation to address 85h of memory.

## I1FSO1–I1FSO0: CURRENT GENERATOR 1 FULL SCALE OUTPUT SET BITS (NON-VOLATILE)

These two bits are used to set the full scale output current at the Current Generator 1 pin, I1. If both bits are set to “0” (default), an external resistor connected between pin R1 and V<sub>SS</sub>, determines the full scale output current available at pin I1. The other three options are indicated in the table below. The direction of this current is set by bit I1DS in Control register 0. See Figure 5.

I1FSO1	I1FSO0	I1 Full Scale Output Current
0	0	Set externally via pin R1 (Default)
0	1	±0.4mA*
1	0	±0.85 mA*
1	1	±1.3 mA*

\*No external resistor should be connected in these cases between R1 and V<sub>SS</sub>.

## I2FSO1–I2FSO0: CURRENT GENERATOR 2 FULL SCALE OUTPUT CURRENT SET BITS (NON-VOLATILE)

These two bits are used to set the full scale output current at the Current Generator 2 pin, I2. If both bits are set to “0” (default), an external resistor connected between pin R2 and Vss, determines the full scale output current available at pin I2. The other three options are indicated in the table below. The direction of this current is set by bit I2DS in Control Register 0.

I2FSO1	I2FSO0	I2 Full Scale Output Current
0	0	Set externally via pin R2 (Default)
0	1	$\pm 0.4\text{mA}^*$
1	0	$\pm 0.85\text{mA}^*$
1	1	$\pm 1.3\text{mA}^*$

\*No external resistor should be connected in these cases between R2 and Vss.

## L1DAS: LUT1 DIRECT ACCESS SELECT BIT (NON-VOLATILE)

When bit L1DAS is set to “0” (default), LUT1 is addressed by the output of the on-chip A/D converter. When bit L1DAS is set to “1”, LUT1 is addressed by bits L1DA5– L1DA0.

## D1DAS: D/A 1 DIRECT ACCESS SELECT BIT (NON-VOLATILE)

When bit D1DAS is set to “0” (default), the input to the D/A converter 1 is a row of LUT1. When bit D1DAS is set to “1”, that input is the content of the Control register 3.

## L2DAS: LUT2 DIRECT ACCESS SELECT BIT (NON-VOLATILE)

When bit L2DAS is set to “0” (default), LUT2 is addressed by the output of the on-chip A/D converter. When bit L2DAS is set to “1”, LUT2 is addressed by bits L2DA5–L2DA0.

## D2DAS: D/A 2 DIRECT ACCESS SELECT BIT (NONVOLATILE)

When bit D2DAS is set to “0” (default), the input to the D/A converter 2 is a row of LUT2. When bit D2DAS is set to “1”, that input is the content of the Control register 4.

## Control Register 6

This register is accessed by performing a Read or Write operation to address 86h of memory.

## WEL: WRITE ENABLE LATCH (VOLATILE)

The WEL bit controls the Write Enable status of the entire X9530 device. This bit must be set to “1” before any other Write operation (volatile or nonvolatile). Otherwise, any proceeding Write operation to memory is aborted and no ACK is issued after a Data Byte.

The WEL bit is a volatile latch that powers up in the “0” state (disabled). The WEL bit is enabled by writing  $1000000_2$  to Control register 6. Once enabled, the WEL bit remains set to “1” until the X9530 is powered down, and then up again, or until it is reset to “0” by writing  $0000000_2$  to Control register 6.

A Write operation that modifies the value of the WEL bit will not cause a change in other bits of Control register 6.

## Status Register – ADC Output

This register is accessed by performing a Read operation to address 87h of memory.

## AD5–AD0: A/D CONVERTER OUTPUT BITS (READ ONLY)

These six bits are the binary output of the on-chip A/D converter. The output is  $000000_2$  for minimum input and  $111111_2$  for full scale input.

## VOLTAGE REFERENCE

The voltage reference to the A/D and D/A converters on the X9530, may be driven from the on-chip voltage reference, or from an external source via the VRef pin. Bit VRM in Control Register 0 selects between the two options (See Figure 2).

The default value of VRM is “0”, which selects the internal reference. When the internal reference is selected, its output voltage is also an output at pin VRef with a nominal value of 1.21 V. If an external voltage reference is preferred, the VRM bit of the Control Register 0 must be set to “1”.

**Figure 2. Voltage Reference Structure**

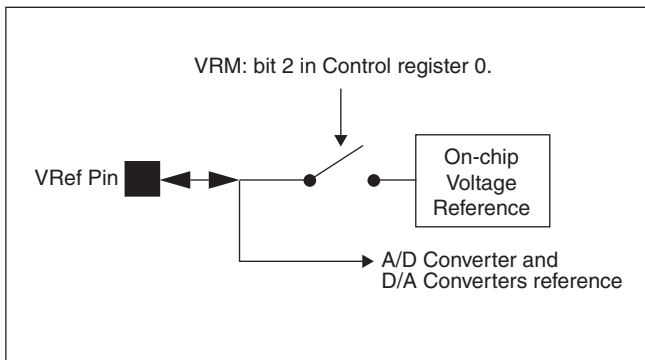

## A/D CONVERTER

The X9530 contains a general purpose, on-chip, 6-bit Analog to Digital (A/D) converter whose output is available at the Status Register as bits AD[5:0]. By default these output bits are used to select a row in the

**Figure 3. A/D Converter Block Diagram**

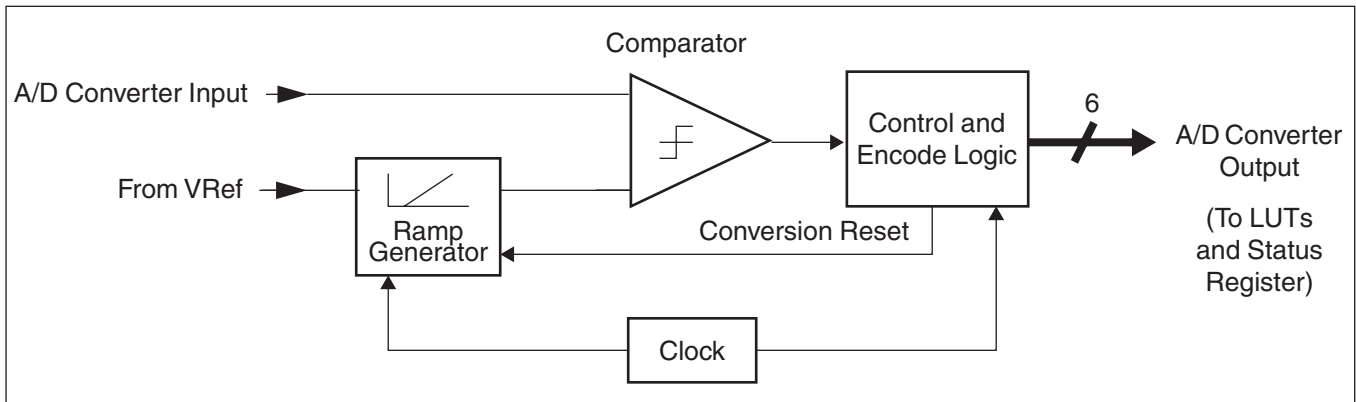

look-up tables associated with the X9530's Current Generators. When bit ADCfiltOff is “0” (default), bits AD[5:0] are updated each time the ADC performs four consecutive conversions with the same exact result. When bit ADCfiltOff is “1”, these bits are updated after every ADC conversion.

A block diagram of the A/D converter is shown in Figure 3. The voltage reference input (see “VOLTAGE REFERENCE” for details), sets the maximum amplitude of the ramp generator output. The A/D converter input signal (see “A/D Converter Input Select” below for details) is compared to the ramp generator output. The control and encode logic produces a binary encoded output, with a minimum value of 00h (0<sub>10</sub>), and a full scale output value of 3Fh (63<sub>10</sub>).

The A/D converter input voltage range (VIN<sub>ADC</sub>) is from 0 V to V(VRef).

## A/D Converter Input Select

The input signal to the A/D converter on the X9530, may be the output of the on-chip temperature sensor, or an external source via the VSense pin. Bit ADCIN in Control register 0 selects between the two options (See Figure 4). Its default value is “0”, which selects the internal temperature sensor.

If an external source is intended as the input to the A/D converter, the ADCIN bit of the Control register 0 must be set to “1”.

Figure 4. A/D Converter Input Select Structure

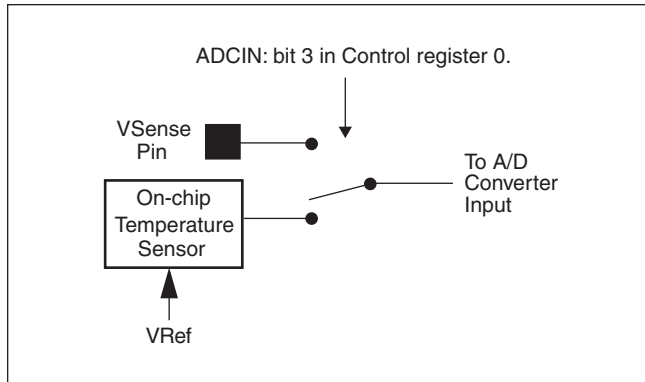

**A/D Converter Range**

From Figure 3 we can see that the operating range of the A/D converter input depends on the voltage reference. And from Figure 4 we see that the internal temperature Sensor output also varies with the voltage reference (VRef).

The table below summarizes the voltage range restrictions on the VSense and VRef pins in different configurations :

**VSense and VRef ranges**

VRef	A/D Converter Input	Ranges
Internal	Internal Temp. Sensor	Not Applicable
Internal	VSense Pin	$0 \leq V(VSense) \leq V(VRef)$
External	VSense Pin	$0 \leq V(VRef) \leq 1.3 V$ $0 \leq V(VSense) \leq V(VRef)$
External	Internal Temp. Sensor	Not a Valid Case
All voltages referred to Vss.		

**LOOK-UP TABLES**

The X9530 memory array contains two 64-byte look-up tables. One is associated to pin I1’s output current generator and the other to pin I2’s output current generator, through their corresponding D/A converters. The output of each look-up table is the byte contained in the selected row. By default these bytes are the inputs to the D/A converters driving pins I1 and I2.

The byte address of the selected row is obtained by adding the look-up table base address (90h for LUT1, and D0h for LUT2) and the appropriate row selection bits. See Figure 6.

By default the look-up table selection bits are the 6-bit output of the A/D converter. Alternatively, the A/D converter can be bypassed and the six row selection bits are the six LSBs of Control Registers 1 and 2, for the LUT1 and LUT2 respectively. The selection between these options is illustrated in Figure 7, and described in “I2DS: Current Generator 2 Direction Select Bit (Non-volatile)” on page 6, and “Control Register 2” on page 6.

**CURRENT GENERATOR BLOCK**

The Current Generator pins I1 and I2 are outputs of two independent current mode D/A converters.

**D/A Converter Operation**

The Block Diagram for each of the D/A converters is shown in Figure 5.

The input byte of the D/A converter selects a voltage on the non-inverting input of an operational amplifier. The output of the amplifier drives the gate of a FET, whose source is connected to ground via resistor R1. This node is also fed back to the inverting input of the amplifier. The drain of the FET is connected to the output current pin (I1) via a “polarity select” circuit block.

Figure 5. D/A Converter Block Diagram

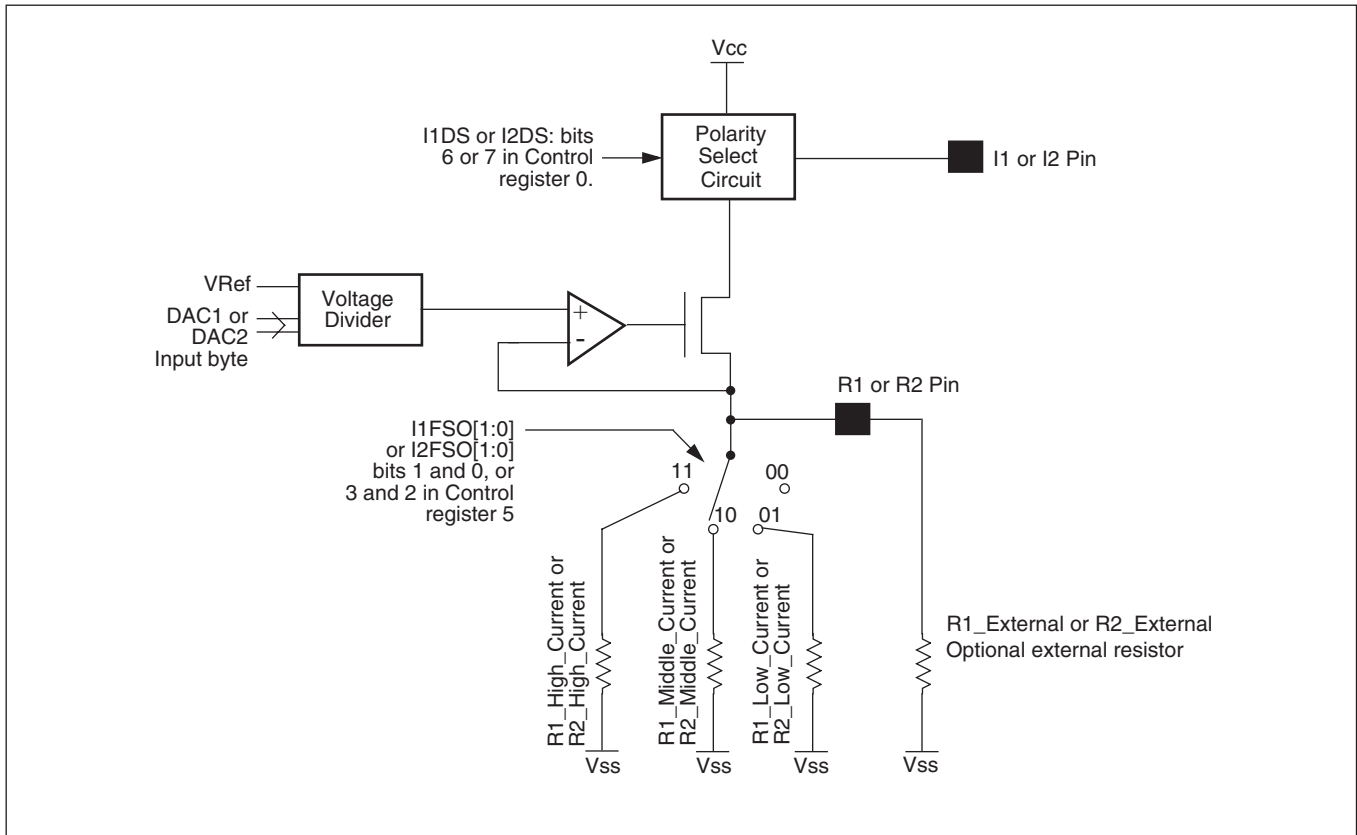
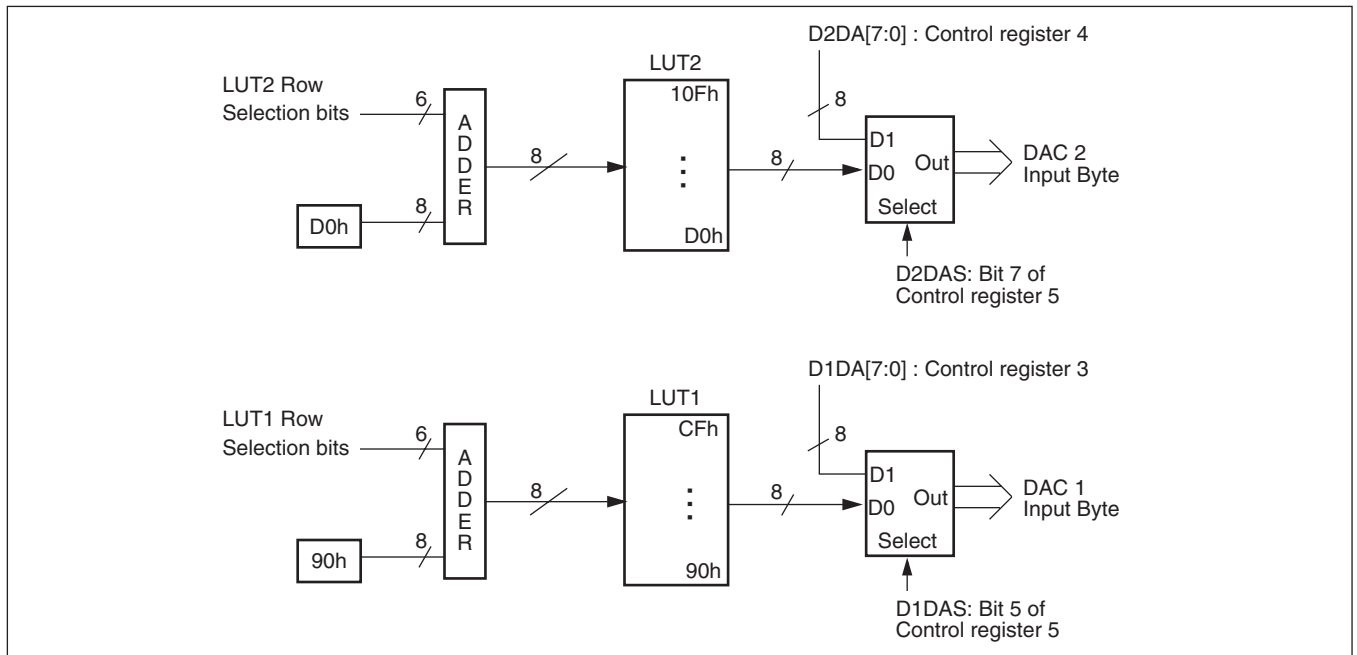

Figure 6. Look-up Table (LUT) Operation



By examining the block diagram in Figure 5, we see that the *maximum* current through pin I1 is set by fixing values for V(VRef) and R1. The output current can then be varied by changing the data byte at the D/A converter input.

In general, the magnitude of the current at the D/A converter output pins (I1, I2) may be calculated by:

$$I_x = (V(VRef) / (384 \cdot R_x)) \cdot N$$

where x =1,2 and N is the decimal representation of the input byte to the corresponding D/A converter.

The value for the resistor Rx (x = 1,2) determines the *full scale output* current that the D/A converter may sink or source. The full scale output current has a maximum value of ±1.6 mA, which is obtained using a resistance of 510Ω for Rx. This resistance may be connected externally to pin Rx of the X9530, or may be selected from one of three internal values. Bits I1FSO1 and I1FSO0 select the full scale output current setting for I1 as described in “I1FSO1–I1FSO0: Current Generator 1 Full Scale Output Set Bits (Non-volatile)” on page 6. Bits I2FSO1 and I2FSO0 select the maximum current setting for I2 as described in “I2FSO1–I2FSO0: Current Generator 2 Full Scale Output Current Set Bits (Non-volatile)” on page 7. When an internal resistor is selected for R1 or R2, then no resistor should be connected externally at the corresponding pin.

Bits I1DS and I2DS in Control Register 0 select the direction of the currents through pins I1 and I2 independently (See “I1DS: Current Generator 1 Direction Select Bit (Non-volatile)” on page 4 and “Control and Status Register Format” on page 5).

### D/A Converter Output Current Response

When the D/A converter input data byte changes by an arbitrary number of bits, the output current changes from an initial current level ( $I_x$ ) to some final level ( $I_x + \Delta I_x$ ). The transition is monotonic and glitchless.

### D/A Converter Control

The data byte inputs of the D/A converters can be controlled in three ways:

- 1) With the A/D converter and through the look-up tables (default),
- 2) Bypassing the A/D converter and directly accessing the look-up tables,
- 3) Bypassing both the A/D converter and look-up tables, and directly setting the D/A converter input byte.

**Figure 7. Look-Up Table Addressing**

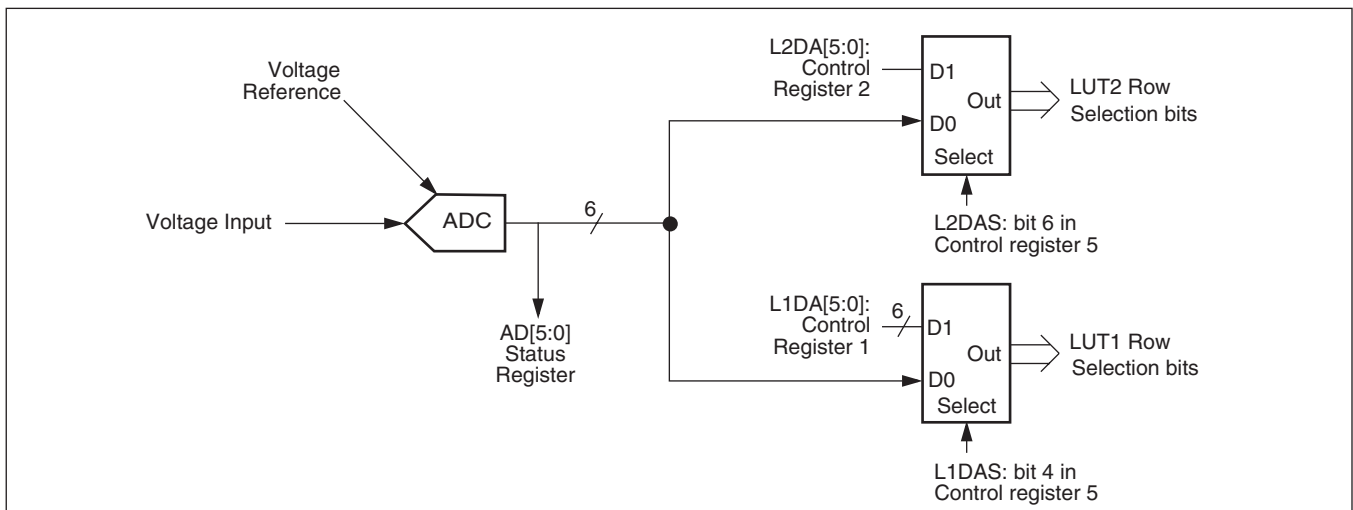

The options are summarized in the following tables:

### D/A Converter 1 Access Summary

L1DAS	D1DAS	Control Source
0	0	A/D converter through LUT1 (Default)
1	0	Bits L1DA5–L1DA0 through LUT1
X	1	Bits D1DA7–D1DA0
“X” = Don’t Care Condition (May be either “1” or “0”)		

### D/A Converter 2 Access Summary

L2DAS	D2DAS	Control Source
0	0	A/D converter through LUT2 (Default)
1	0	Bits L2DA5–L2DA0 through LUT2
X	1	Bits D2DA7–D2DA0
“X” = Don’t Care Condition (May be either “1” or “0”)		

The A/D converter is shared between the two current generators but the look-up tables, D/A converters, control bits, and selection bits can be set completely independently.

Bits D1DAS and D2DAS are used to bypass the A/D converter and look-up tables, allowing direct access to the inputs of the D/A converters with the bytes in control registers 4 and 5 respectively. See Figure 6, and the descriptions of the control bits.

Bits I1DS and I2DS in Control Register 0 select the direction of the currents through pins I1 and I2 independently. See Figure 5, and the descriptions of the control bits.

### POWER ON RESET

When power is applied to the Vcc pin of the X9530, the device undergoes a strict sequence of events before the current outputs of the D/A converters are enabled.

When the voltage at Vcc becomes larger than the power on reset threshold voltage ( $V_{POR}$ ), the device recalls all control bits from non-volatile memory into volatile registers. Next, the analog circuits are powered up. When the voltage at Vcc becomes larger than a second voltage threshold ( $V_{ADCOK}$ ), the ADC is enabled. In the default case, after the ADC performs four consecutive conversions with the same exact result, the ADC output is used to select a byte from each look-up table. Those bytes become the input of the DACs. During all the previous sequence the input of both DACs are 00h. If bit ADCfiltOff is “1”, only one ADC conversion is necessary. Bits D1DAS, D2DAS, L1DAS, and L2DAS, also modify the way the two DACs are accessed the first time after power up, as described in “Control Register 5” on page 6.

The X9530 is a hot pluggable device. Voltage disturbances on the Vcc pin are handled by the power-on reset circuit, allowing proper operation during hot plug-in applications.

### SERIAL INTERFACE

#### Serial Interface Conventions

The device supports a bidirectional bus oriented protocol. The protocol defines any device that sends data onto the bus as a transmitter, and the receiving device as the receiver. The device controlling the transfer is called the master and the device being controlled is called the slave. The master always initiates data transfers, and provides the clock for both transmit and receive operations. The X9530 operates as a slave in all applications.

Figure 8. D/A Converter Power on Reset Response

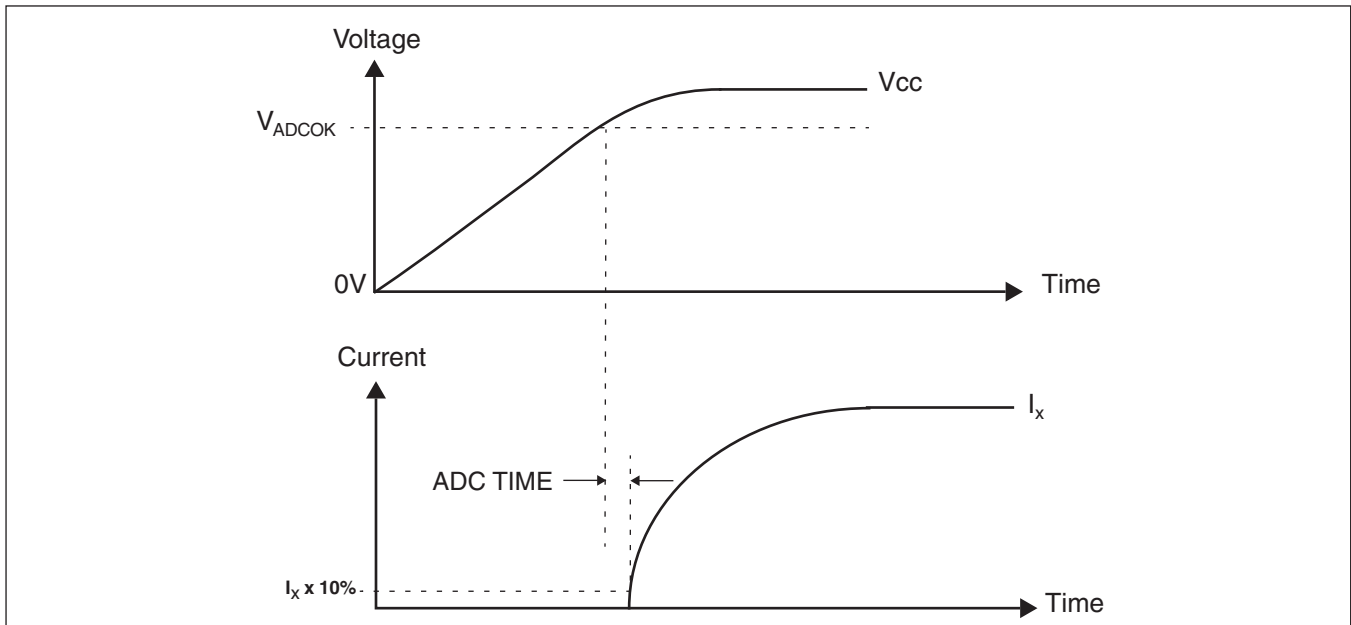

**Serial Clock and Data**

Data states on the SDA line can change only while SCL is LOW. SDA state changes while SCL is HIGH are reserved for indicating START and STOP conditions. See Figure 10. On power up of the X9530, the SDA pin is in the input mode.

**Serial Start Condition**

All commands are preceded by the START condition, which is a HIGH to LOW transition of SDA while SCL is HIGH. The device continuously monitors the SDA and SCL lines for the START condition and does not respond to any command until this condition has been met. See Figure 9.

**Serial Stop Condition**

All communications must be terminated by a STOP condition, which is a LOW to HIGH transition of SDA while SCL is HIGH. The STOP condition is also used to place the device into the Standby power mode after a read sequence. A STOP condition can only be issued after the transmitting device has released the bus. See Figure 9.

**Serial Acknowledge**

An ACK (Acknowledge), is a software convention used to indicate a successful data transfer. The transmitting device, either master or slave, releases the bus after

transmitting eight bits. During the ninth clock cycle, the receiver pulls the SDA line LOW to acknowledge the reception of the eight bits of data. See Figure 11.

The device responds with an ACK after recognition of a START condition followed by a valid Slave Address byte. A valid Slave Address byte must contain the Device Type Identifier 1010, and the Device Address bits matching the logic state of pins A2, A1, and A0. See Figure 13.

If a write operation is selected, the device responds with an ACK after the receipt of each subsequent eight-bit word.

In the read mode, the device transmits eight bits of data, releases the SDA line, and then monitors the line for an ACK. The device continues transmitting data if an ACK is detected. The device terminates further data transmissions if an ACK is not detected. The master must then issue a STOP condition to place the device into a known state.

The X9530 acknowledges all incoming data and address bytes except: 1) The “Slave Address Byte” when the “Device Identifier” or “Device Address” are wrong; 2) All “Data Bytes” when the “WEL” bit is “0”, with the exception of a “Data Byte” addresses to location 86h; 3) “Data Bytes” following a “Data Byte” addressed to locations 80h, 85h, or 86h.

Figure 9. Valid Start and Stop Conditions

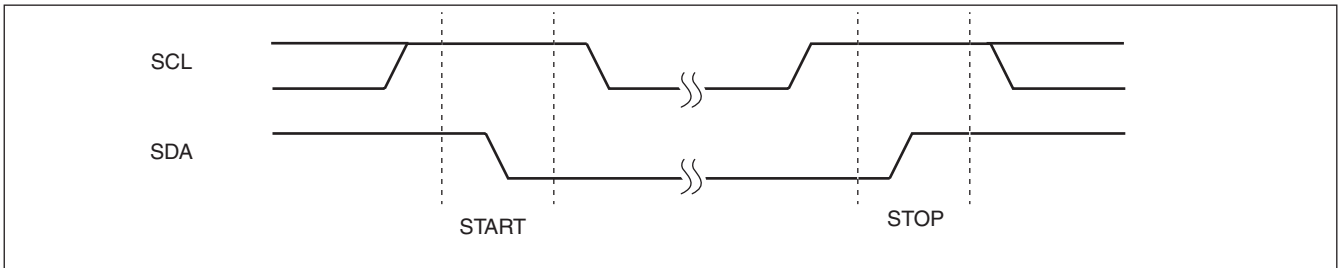

Figure 10. Valid Data Changes on the SDA Bus

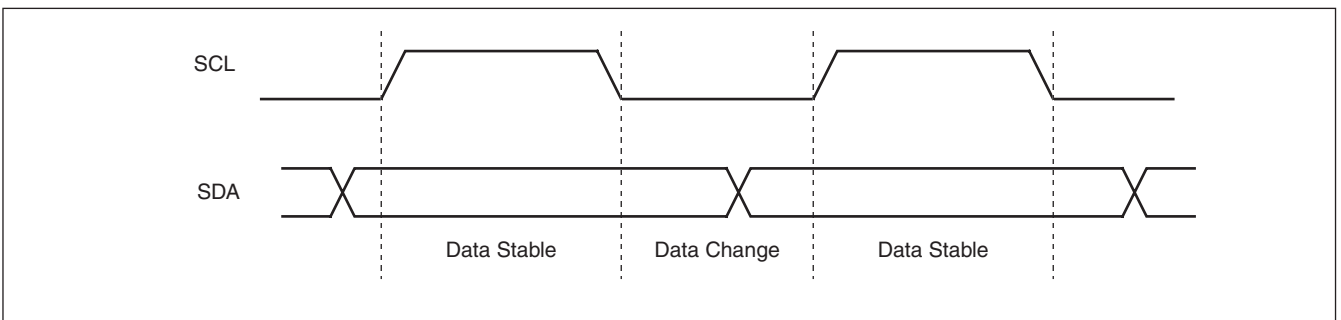
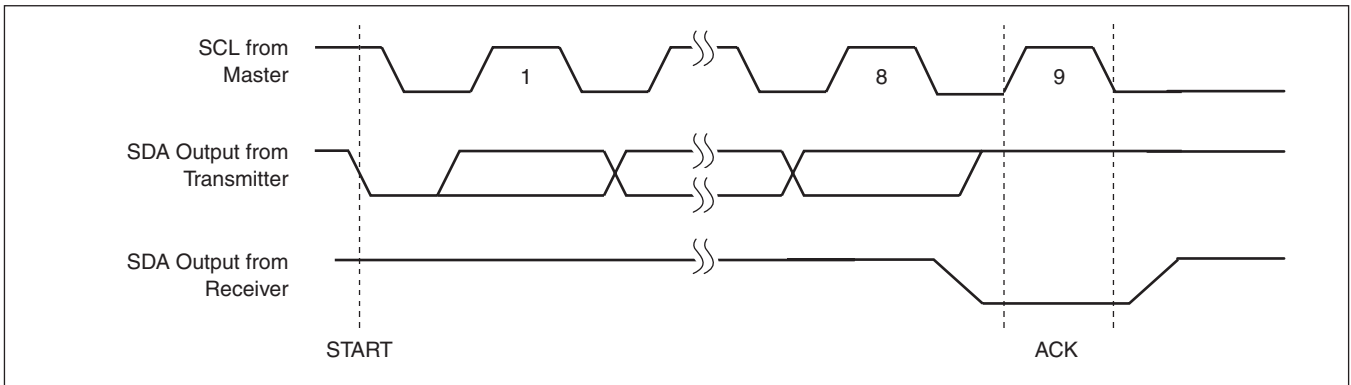

Figure 11. Acknowledge Response From Receiver



# X9530

## X9530 Memory Map

The X9530 contains a 2176 bit array of mixed volatile and nonvolatile memory. This array is split up into four distinct parts, namely: (Refer to Figure 12.)

- General Purpose Memory (GPM)
- Look-up Table 1 (LUT1)
- Look-up Table 2 (LUT2)
- Control and Status Registers

The GPM is all nonvolatile EEPROM, located at memory addresses 00h to 7Fh.

**Figure 12. X9530 Memory Map**

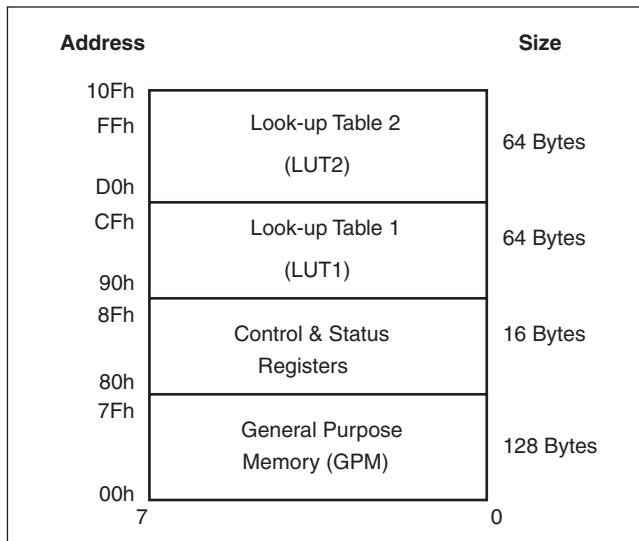

The Control and Status registers of the X9530 are used in the test and setup of the device in a system. These registers are realized as a combination of both volatile and nonvolatile memory. These registers reside in the memory locations 80h through 8Fh. The reserved bits within registers 80h through 86h, must be written as “0” if writing to them, and should be ignored when reading. The reserved registers, from 88h through 8Fh, must not be written, and their content should be ignored.

Both look-up tables LUT1 and LUT2 are realized as nonvolatile EEPROM, and extend from memory locations 90h–CFh and D0h–10Fh respectively. These look-up tables are dedicated to storing data solely for the purpose of setting the outputs of Current Generators I1 and I2 respectively.

All bits in both look-up tables are preprogrammed to “0” at the factory.

## Addressing Protocol Overview

All Serial Interface operations must begin with a START, followed by a Slave Address Byte. The Slave address selects the X9530, and specifies if a Read or Write operation is to be performed.

It should be noted that the Write Enable Latch (WEL) bit must first be set in order to perform a Write operation to any other bit. (See “WEL: Write Enable Latch (Volatile)” on page 7.) Also, all communication to the X9530 over the 2-wire serial bus is conducted by sending the MSB of each byte of data first.

Even though the 2176 bit memory consists of four differing functions, it is physically realized as one contiguous array, organized as 17 pages of 16 bytes each.

The X9530 2-wire protocol provides one address byte, therefore, only 256 bytes can be addressed directly. The next few sections explain how to access the different areas for reading and writing.

**Figure 13. Slave Address (SA) Format**

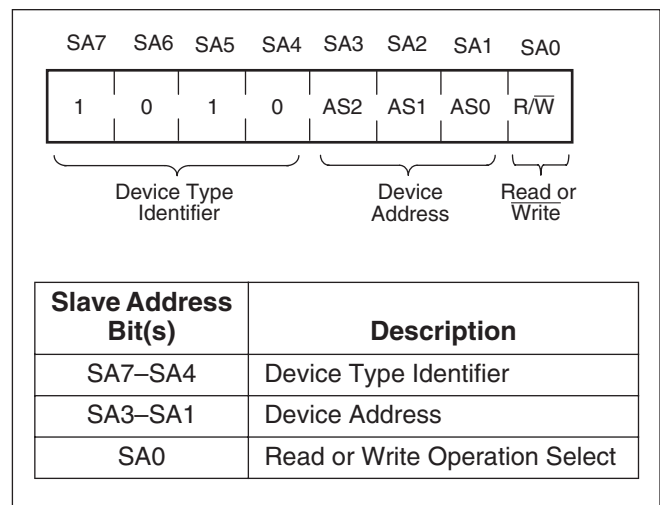

## Slave Address Byte

Following a START condition, the master must output a Slave Address Byte (Refer to Figure 13.). This byte includes three parts:

- The four MSBs (SA7-SA4) are the Device Type Identifier, which must always be set to 1010 in order to select the X9530.
- The next three bits (SA3-SA1) are the Device Address bits (AS2-AS0). To access any part of the X9530's memory, the value of bits AS2, AS1, and AS0 must correspond to the logic levels at pins A2, A1, and A0 respectively.
- The LSB (SA0) is the R/W bit. This bit defines the operation to be performed on the device being addressed. When the R/W bit is "1", then a Read operation is selected. A "0" selects a Write operation (Refer to Figure 13.)

## Nonvolatile Write Acknowledge Polling

After a nonvolatile write command sequence is correctly issued (including the final STOP condition), the X9530 initiates an internal high voltage write cycle. This cycle typically requires 5 ms. During this time, any Read or Write command is ignored by the X9530. Write Acknowledge Polling is used to determine whether a high voltage write cycle is completed.

During acknowledge polling, the master first issues a START condition followed by a Slave Address Byte. The Slave Address Byte contains the X9530's Device Type Identifier and Device Address. The LSB of the Slave Address (R/W) can be set to either 1 or 0 in this case. If the device is busy within the high voltage cycle, then no ACK is returned. If the high voltage cycle is completed, an ACK is returned and the master can then proceed with a new Read or Write operation. (Refer to Figure 14.)

**Figure 14. Acknowledge Polling Sequence**

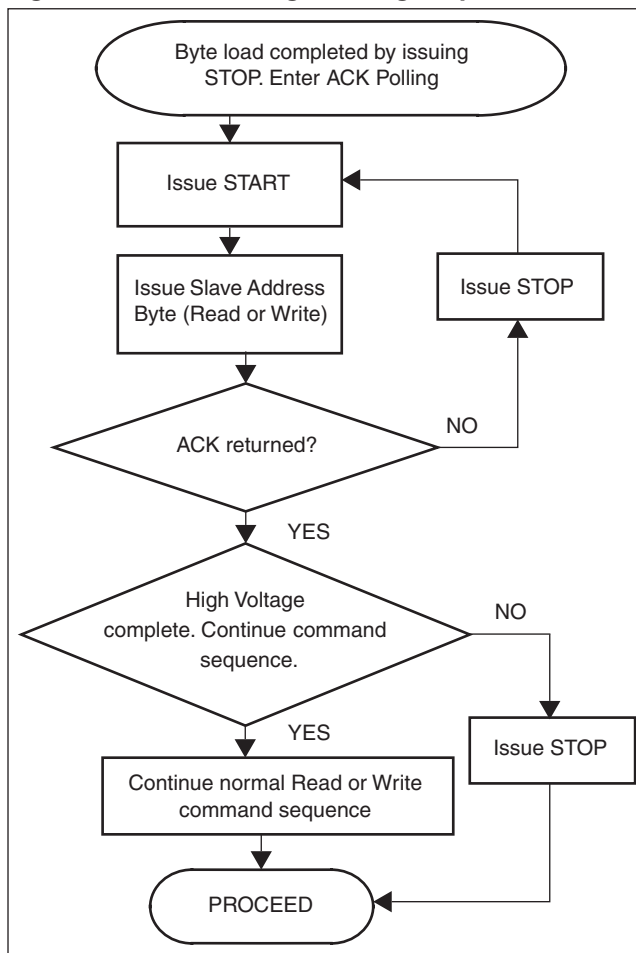

## Byte Write Operation

In order to perform a Byte Write operation to the memory array, the Write Enable Latch (WEL) bit of the Control 6 Register must first be set to "1". (See "WEL: Write Enable Latch (Volatile)" on page 7.)

For any Byte Write operation, the X9530 requires the Slave Address Byte, an Address Byte, and a Data Byte (See Figure 15). After each of them, the X9530 responds with an ACK. The master then terminates the transfer by generating a STOP condition. At this time, if all data bits are volatile, the X9530 is ready for the next read or write operation. If some bits are nonvolatile, the X9530 begins the internal write cycle to the nonvolatile memory. During the internal nonvolatile write cycle, the X9530 does not respond to any requests from the master. The SDA output is at high impedance.

A Byte Write operation can access bytes at locations 00h through FEh directly, when setting the Address Byte to 00h through FEh respectively. Setting the Address Byte to FFh accesses the byte at location 100h. The other sixteen bytes, at locations FFh and 101h through 10Fh can only be accessed using Page Write operations. The byte at location FFh can only be written using a "Page Write" operation.

Writing to Control bytes which are located at byte addresses 80h through 8Fh is a special case described in the section "Writing to Control Registers".

Figure 15. Byte Write Sequence

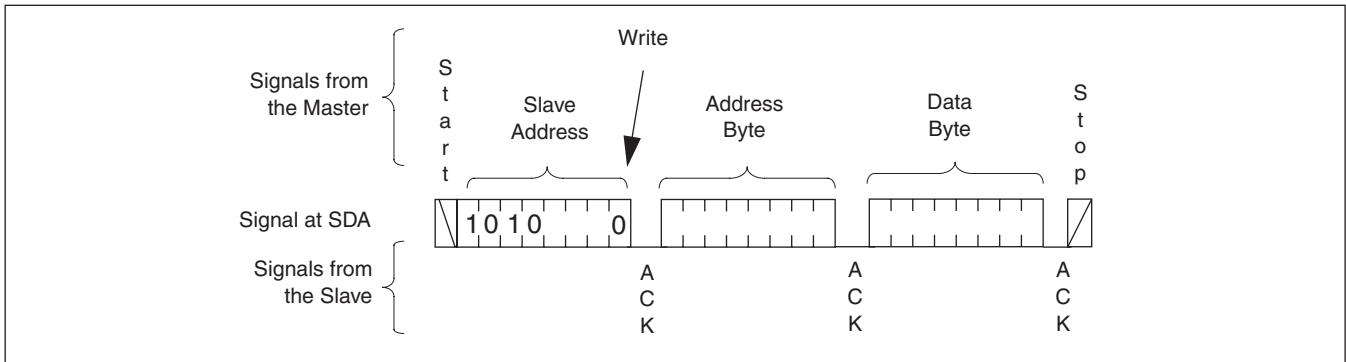

**Page Write Operation**

The 2176-bit memory array is physically realized as one contiguous array, organized as 17 pages of 16 bytes each. In order to perform a Page Write operation to the memory array, the Write Enable Latch (WEL) bit in Control register 6 must first be set (See “WEL: Write Enable Latch (Volatile)” on page 7.)

A Page Write operation is initiated in the same manner as the byte write operation; but instead of terminating the write cycle after the first data byte is transferred, the master can transmit up to 16 bytes (See Figure 16). After the receipt of each byte, the X9530 responds with an ACK, and the internal byte address counter is incremented by one. The page address remains constant. When the counter reaches the end of the page, it “rolls over” and goes back to the first byte of the same page.

For example, if the master writes 12 bytes to a 16-byte page starting at location 11 (decimal), the first 5 bytes are written to locations 11 through 15, while the last 7 bytes are written to locations 0 through 6 within that page. Afterwards, the address counter would point to location 7. If the master supplies more than 16 bytes of data, then new data overwrites the previous data, one byte at a time (See Figure 17).

The master terminates the loading of Data Bytes by issuing a STOP condition, which initiates the nonvolatile write cycle. As with the Byte Write operation, all inputs are disabled until completion of the internal write cycle.

A Page Write operation cannot be performed on the page at locations 80h through 8Fh. Next section describes the special cases within that page.

A Page Write operation starting with byte address FFh, accesses the page between locations 100h and 10Fh. The first data byte of such operation is written to location 100h.

**Writing to Control Registers**

The byte at location 80h, and bytes at locations 85h through 8Fh are written using Byte Write operations. They cannot be written using a Page Write operation.

Control bytes 1 through 4, at locations 81h through 84h respectively, are written during a single operation (See Figure 18). The sequence must be: a START, followed by a Slave Address byte, with the R/W bit equal to “0”, followed by 81h as the Address Byte, and then followed by exactly four Data Bytes, and a STOP

Figure 16. Page Write Operation

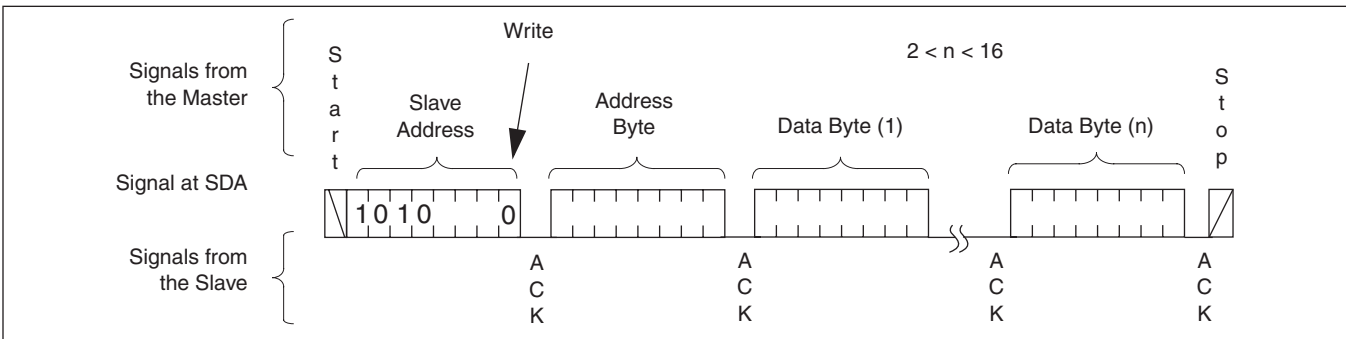
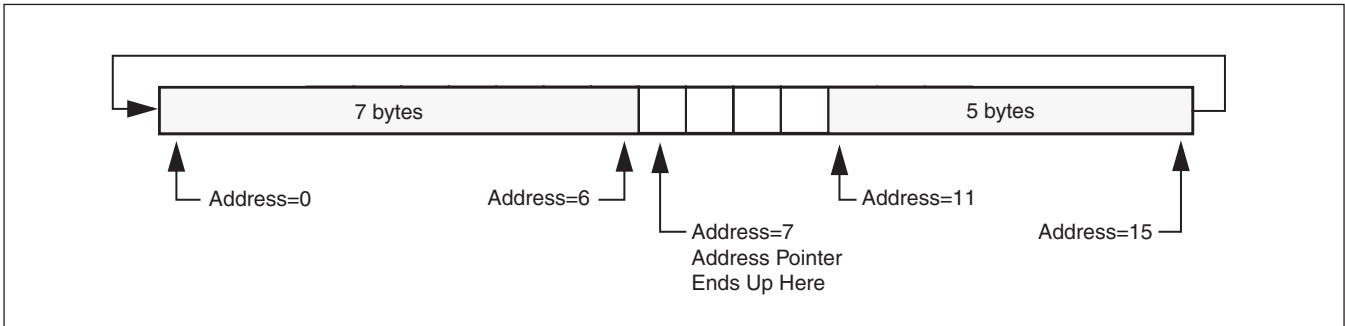

Figure 17. Example: Writing 12 bytes to a 16-byte page starting at location 11.



condition. The first data byte is written to location 81h, the second to 82h, the third to 83h, and the last one to 84h.

The four registers Control 1 through 4, have a nonvolatile and a volatile cell for each bit. At power up, the content of the nonvolatile cells is automatically recalled and written to the volatile cells. The content of the volatile cells controls the X9530’s functionality. If bit NV1234 in the Control 0 register is set to “1”, a Write operation to these registers writes to both the volatile and nonvolatile cells. If bit NV1234 in the Control 0 register is set to “0”, a Write operation to these registers only writes to the volatile cells. In both cases the newly written values effectively control the X9530, but in the second case, those values are lost when the part is powered down.

If bit NV1234 is set to “0”, a Byte Write operation to Control registers 0 or 5 causes the value in the nonvolatile cells of Control registers 1 through 4 to be recalled into their corresponding volatile cells, as during power up. This doesn’t happen when the WP pin is LOW, because Write Protection is enabled. It is generally recommended to configure Control registers 0 and 5 before writing to Control registers 1 through 4.

When reading any of the control registers 1, 2, 3, or 4, the Data Bytes are always the content of the corresponding nonvolatile cells, even if bit NV1234 is “0” (See “Control and Status Register Format”).

**Read Operation**

A Read operation consist of a three byte instruction followed by one or more Data Bytes (See Figure 19). The master initiates the operation issuing the following sequence: a START, the Slave Address byte with the R/W bit set to “0”, an Address Byte, a second START, and a second Slave Address byte with the R/W bit set to “1”. After each of the three bytes, the X9530 responds with an ACK. Then the X9530 transmits Data Bytes as long as the master responds with an ACK during the SCL cycle following the eighth bit of each byte. The master terminates the read operation (issuing a STOP condition) following the last bit of the last Data Byte (See Figure 19).

The Data Bytes are from the memory location indicated by an internal pointer. This pointer initial value is determined by the Address Byte in the Read operation instruction, and increments by one during transmission of

Figure 18. Writing to Control Registers 1, 2, 3, and 4

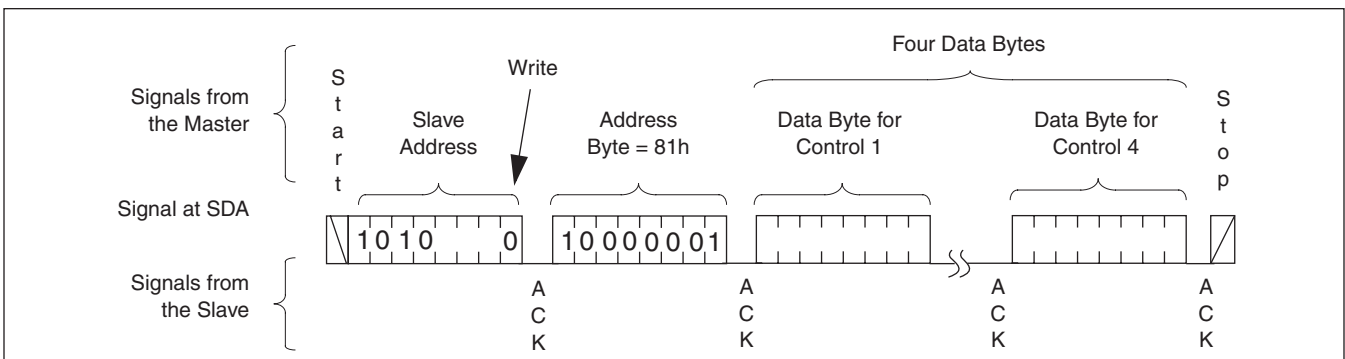
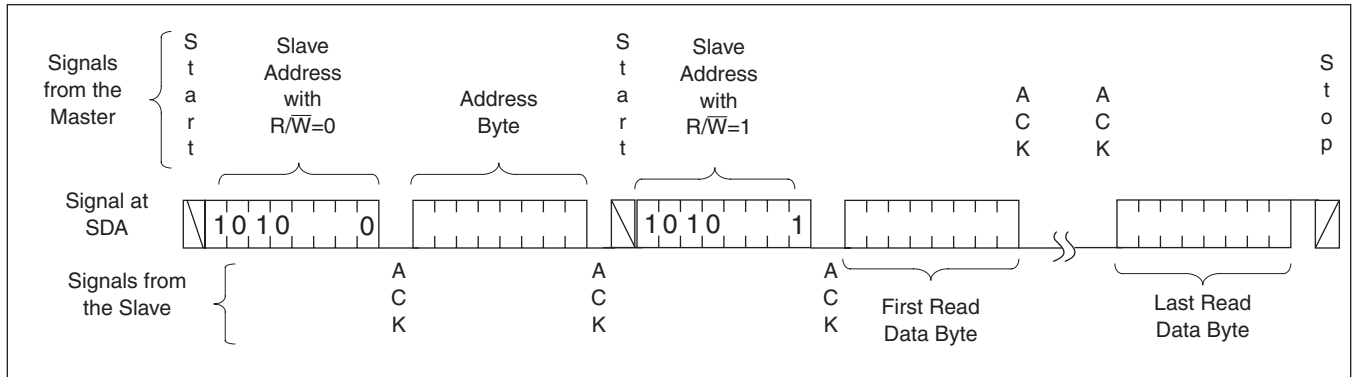

Figure 19. Read Sequence



each Data Byte. After reaching the memory location 10Fh the pointer “rolls over” to 00h, and the device continues to output data for each ACK received.

A Read operation internal pointer can start at any memory location from 00h through FEh, when the Address Byte is 00h through FEh respectively. But it starts at location 100h if the Address Byte is FFh.

When reading any of the control registers 1, 2, 3, or 4, the Data Bytes are always the content of the corresponding nonvolatile cells, even if bit NV1234 is “0” (See “Control and Status Register Format”).

**Data Protection**

There are four levels of data protection designed into the X9530: 1- Any Write to the device first requires setting of the WEL bit in Control 6 register; 2- The Block Lock can prevent Writes to certain regions of memory; 3- The Write Protection pin disables any writing to the X9530; 4- The proper clock count, data bit sequence, and STOP condition is required in order to start a nonvolatile write cycle, otherwise the X9530 ignores the Write operation.

**$\overline{WP}$ : Write Protection Pin**

When the Write Protection ( $\overline{WP}$ ) pin is active (LOW), any Write operations to the X9530 is disabled, except the writing of the WEL bit.

## APPLICATIONS INFORMATION

### Temperature Sensing

The X9530's on-chip temperature sensor functions similarly to other semiconductor temperature sensors. The surface mount package (TSSOP) and the Chip Scale Package both allow good thermal conduction from the PC board to the die, so the X9530 will provide an accurate measure of the temperature of the board. If there is no ambient air movement over the device package or the board, then the measured temperature will be very close to that of the board. If there is air movement over the package and the air temperature is substantially different from that of the PC board, then the measured temperature will be at a value between that of the board and the air. If the X9530 is intended to sense the temperature of a particular component on the board, the X9530 should be located as close as possible to that component to minimize contributions from other devices or the differential temperatures across the board.

### X9530 LASER DIODE BIAS APPLICATION EXAMPLE

The X9530 is ideally suited to the control of temperature sensitive parameters in fiber optic applications. Figure 20 shows the typical topology of a laser driver circuit used in many fiber optic transceiver modules.

This example uses a common anode connected Laser Diode (LD), in conjunction with a PIN Monitor Photo-Diode (MPD). The laser diode current ( $I_{LD}$ ) is a summation of the Bias Current ( $I_{BIAS}$ ), Modulation Current ( $I_{MOD}$ ) and the Automatic Power Control (APC) error signal current ( $I_{MON}$ ). The APC circuit uses the MPD current ( $I_{MON}$ ) as an input, and ensures that a constant average optical power output of the LD is maintained. The modulation circuitry is driven by an external high speed data source.

Typical control parameters of a LD driver circuit such as the one shown in Figure 20 may be:

- $I_{MODSET}$  : Sets the  $I_{MOD}$  level,
- $I_{BIASSET}$  : Sets the  $I_{BIAS}$  level,
- $I_{PINSET}$ : Sets the average optical power output.

Figure 21 shows how the X9530 may be used to control these parameters while providing accurate temperature compensation.

In this example the I1 output of the X9530 drives the  $I_{MODSET}$  input of the laser diode circuit. By loading the appropriate values into the look-up table (LUT1) of the device, it can dynamically change the modulation current of the driver circuit. This may be used to compensate for the effect of reduced laser light output at elevated temperatures.

Depending upon the type of driver circuit used, the I2 output of the X9530 may be used to control either  $I_{BIASSET}$  or  $I_{PINSET}$  parameters. The example in Figure 21 uses I2 to control the  $I_{PINSET}$  parameter, while  $I_{BIASSET}$  is set at a fixed value using a Xicor Digital potentiometer.

Similar to the control of the modulation current, I2 may be used to compensate for changes in  $I_{MON}$  over temperature. By loading the appropriate values into the look-up table (LUT2) of the device, this would have the effect of dynamically controlling the average optical power output of the LD (via the APC circuit) over temperature.

The lookup table values for this fiber optic application could be determined in two ways. One way is to use well-defined data for LD and monitor photo diode drift over temperature, and calculate the appropriate I1 and I2 values needed at each temperature setting. Another way is to test the assembled module over temperature and load values into the tables at each setting. This will require APC on/off control to determine each MODSET value. See Xicor application note AN156 for a full design analysis with LD driver application.

If design requirements are such that no temperature compensation is necessary for the average optical power output of the LD, then the I2 output pin could be used to set the bias current.  $I_{BIASSET}$  of the driver circuit may be controlled by I2 of the X9530, and the same current level could be set with control 4 register. This would provide a constant (temperature independent) setting for the bias current.

As previously described, the X9530 also contains general purpose EEPROM memory which may be accessed by the 2 wire serial bus. In the case of pluggable fiber optic applications such as GBIC, SFP or SFF this memory may be used for the storage of transceiver module parameters.

Figure 20. Typical Laser Driver Circuit Topology

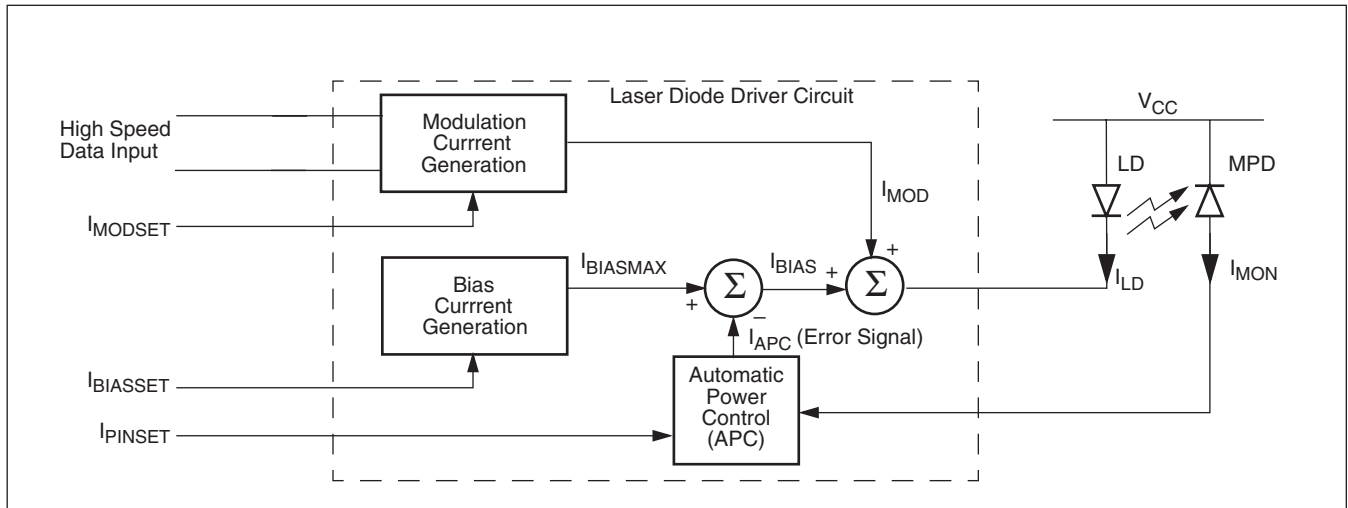
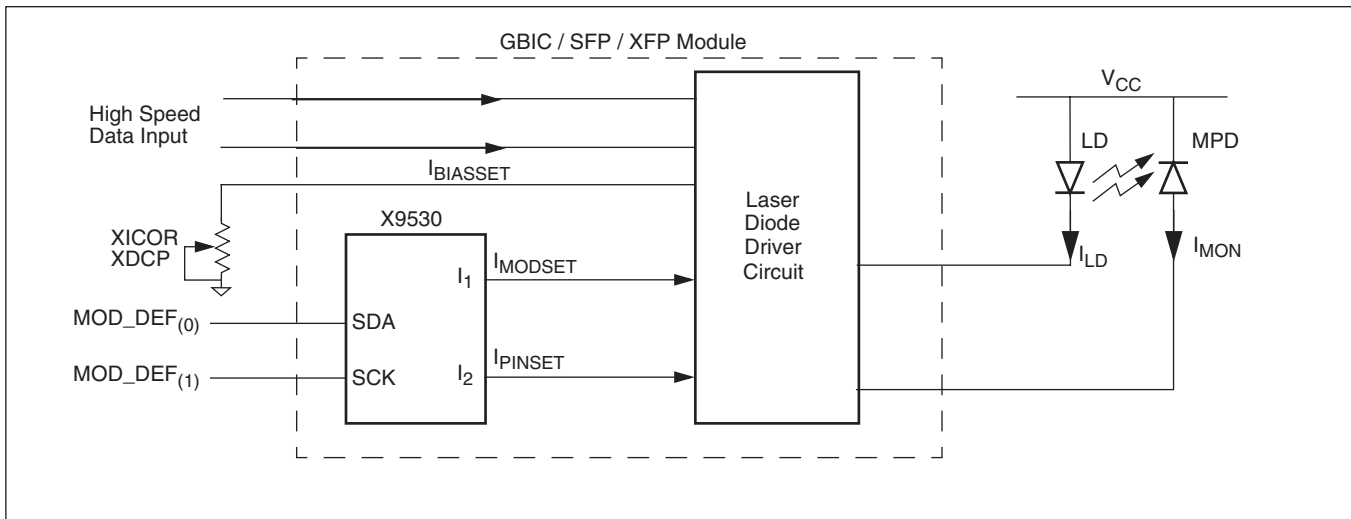

Figure 21. X9530 Application Example Block Diagram



# X9530

## ABSOLUTE MAXIMUM RATINGS

All voltages are referred to Vss.  
 Temperature under bias ..... -65°C to +100°C  
 Storage temperature ..... -65°C to +150°C  
 Voltage on every pin except Vcc.....-1.0V to +7V  
 Voltage on Vcc Pin ..... 0 to 5.5V  
 D.C. Output Current at pin SDA..... 0 to 5 mA  
 D.C. Output Current at pins R1, R2,  
 VRef and VSense .....-0.50 to 1 mA  
 D.C. Output Current at pins I1 and I2 .....-3 to 3mA  
 Lead temperature (soldering, 10 seconds)..... 300°C

## COMMENT

Stresses above those listed under “Absolute Maximum Ratings” may cause permanent damage to the device. This is a stress rating only; functional operation of the device (at these or any other conditions above those listed in the operational sections of this specification) is not implied. Exposure to absolute maximum rating conditions for extended periods may affect device reliability.

## OPERATING CONDITIONS

Parameter	Min.	Max.	Units
Temperature	-40	+100	°C
Temperature while writing to memory	0	+70	°C
Voltage on Vcc Pin	3	5.5	V
Voltage on any other Pin	-0.3	Vcc + 0.3	V

## ELECTRICAL CHARACTERISTICS

All typical values are for 25°C ambient temperature and 5 V at pin Vcc. Maximum and minimum specifications are over the recommended operating conditions. All voltages are referred to the voltage at pin Vss unless otherwise specified. All bits in control registers are “0” unless otherwise specified. 510Ω, 0.1%, resistor connected between R1 and Vss, and another between R2 and Vss unless otherwise specified. 400kHz TTL input at SCL unless otherwise specified. SDA pulled to Vcc through an external 2KΩ resistor unless otherwise specified. 2-wire interface in “standby” (see notes 1 and 2 on page 22), unless otherwise specified. WP, A0, A1, and A2 floating unless otherwise specified. VRef pin unloaded, unless otherwise specified.

Symbol	Parameter	Min	Typ	Max	Unit	Test Conditions / Notes
Iccstby	Standby current into Vcc pin			2	mA	R1 and R2 floating, VRef unloaded.
Iccfull	Full operation current into Vcc pin			9	mA	2-wire interface reading from memory, I <sub>1</sub> and I <sub>2</sub> both connected to Vss, DAC input bytes: FFh, VRef unloaded.
Iccwrite	Nonvolatile Write current into Vcc pin		4		mA	Average from START condition until t <sub>WPP</sub> after the STOP condition WP: Vcc, R1 and R2 floating, VRef unloaded.
I <sub>PLDN</sub>	On-chip pull down current at WP, A0, A1, and A2	0	1	20	μA	V(WP), V(A0), V(A1), and V(A2) from 0V to Vcc
V <sub>ILTTL</sub>	SCL and SDA, input Low voltage			0.8	V	
V <sub>IHTTL</sub>	SCL and SDA, input High voltage	2.0			V	
I <sub>INTTL</sub>	SCL and SDA input current	-1		10	μA	Pin voltage between 0 and Vcc, and SDA as an input.

## ELECTRICAL CHARACTERISTICS (CONTINUED)

All typical values are for 25°C ambient temperature and 5 V at pin Vcc. Maximum and minimum specifications are over the recommended operating conditions. All voltages are referred to the voltage at pin Vss unless otherwise specified. All bits in control registers are “0” unless otherwise specified. 510Ω, 0.1%, resistor connected between R1 and Vss, and another between R2 and Vss unless otherwise specified. 400kHz TTL input at SCL unless otherwise specified. SDA pulled to Vcc through an external 2KΩ resistor unless otherwise specified. 2-wire interface in “standby” (see notes 1 and 2 on page 22), unless otherwise specified.  $\overline{WP}$ , A0, A1, and A2 floating unless otherwise specified. VRef pin unloaded, unless otherwise specified.

Symbol	Parameter	Min	Typ	Max	Unit	Test Conditions / Notes
V <sub>OLSDA</sub>	SDA output Low voltage	0		0.4	V	I(SDA) = 2 mA
I <sub>OHSDA</sub>	SDA output High current	0		100	μA	V(SDA) = V <sub>cc</sub>
V <sub>ILCMOS</sub>	$\overline{WP}$ , A0, A1, and A2 input Low voltage	0		0.2 x V <sub>cc</sub>	V	
V <sub>IHCMOS</sub>	$\overline{WP}$ , A0, A1, and A2 input High voltage	0.8 x V <sub>cc</sub>		V <sub>cc</sub>	V	
V <sub>Refout</sub>	Output Voltage at VRef at 25°C	1.205	1.21	1.215	V	-20 μA ≤ I(VRef) ≤ 20 μA
R <sub>Vref</sub>	VRef pin input resistance	20		40	kΩ	VRM bit = “1”, 25°C
TC <sub>Oref</sub>	Temperature coefficient of VRef output voltage	-100		+100	ppm/°C	See note 4 and 5.
V <sub>Ref Range</sub>	Voltage range when VRef is an input	1		1.3	V	See note 3.
T <sub>SenseRange</sub>	Temperature sensor range	-40		100	°C	See note 4.
I <sub>R</sub>	Current from pin R1 or R2 to Vss	0		1600	μA	
V <sub>POR</sub>	Power on reset threshold voltage	1.5		2.8	V	
V <sub>ccRamp</sub>	Vcc Ramp Rate	0.2		50	mV / μs	
V <sub>ADCOK</sub>	ADC enable minimum voltage	2.6		2.8	V	See Figure 8.

- Notes:**
1. The device goes into Standby: 200 ns after any STOP, except those that initiate a nonvolatile write cycle. It goes into Standby t<sub>WC</sub> after a STOP that initiates a nonvolatile write cycle. It also goes into Standby 9 clock cycles after any START that is not followed by the correct Slave Address Byte.
  2. t<sub>WC</sub> is the time from a valid STOP condition at the end of a write sequence to the end of the self-timed internal nonvolatile write cycle. It is the minimum cycle time to be allowed for any nonvolatile write by the user, unless Acknowledge Polling is used.
  3. For this range of V(VRef) the full scale sink mode current at I1 and I2 follows V(VRef) with a linearity error smaller than 1%.
  4. These parameters are periodically sampled and not 100% tested.
  5.  $TC_{Oref} = [\text{Max } V(V_{REF}) - \text{Min } V(V_{REF})] \times 10^6 / (1.21V \times 140^\circ\text{C})$

## D/A CONVERTER CHARACTERISTICS

All typical values are for 25°C ambient temperature and 5 V at pin Vcc. Maximum and minimum specifications are over the recommended operating conditions. All voltages are referred to the voltage at pin Vss unless otherwise specified. All bits in control registers are “0” unless otherwise specified. 510Ω, 0.1%, resistor connected between R1 and Vss, and another between R2 and Vss unless otherwise specified. 400kHz TTL input at SCL unless otherwise specified. SDA pulled to Vcc through an external 2KΩ resistor unless otherwise specified. 2-wire interface in “standby” (see notes 1 and 2 on page 22), unless otherwise specified.  $\overline{WP}$ , A0, A1, and A2 floating unless otherwise specified.

Symbol	Parameter	Min	Typ	Max	Unit	Test Conditions / Notes
IFS <sub>00</sub>	I1 or I2 full scale current, with external resistor setting	1.56	1.58	1.6	mA	DAC input Byte = FFh, Source or sink mode, V(I1) and V(I2) are Vcc-1.2V in source mode and 1.2V in sink mode. See notes 1 and 2.
IFS <sub>01</sub>	I1 or I2 full scale current, with internal low current setting option	0.3	0.4	0.5	mA	
IFS <sub>10</sub>	I1 or I2 full scale current, with internal middle current setting option	0.64	0.85	1.06	mA	
IFS <sub>11</sub>	I1 or I2 full scale current, with internal high current setting option	1	1.3	1.6	mA	
Offset <sub>DAC</sub>	I1 or I2 D/A converter offset error	1		1	LSB	
FSError <sub>DAC</sub>	I1 or I2 D/A converter full scale error	-2		2	LSB	
DNL <sub>DAC</sub>	I1 or I2 D/A converter Differential Nonlinearity	-0.5		0.5	LSB	
INL <sub>DAC</sub>	I1 or I2 D/A converter Integral Nonlinearity with respect to a straight line through 0 and the full scale value	-1		1	LSB	
VISink	I1 or I2 Sink Voltage Compliance	1.2		Vcc	V	In this range the current at I1 or I2 vary < 1%
VISource	I1 or I2 Source Voltage Compliance	0		Vcc-1.2	V	In this range the current at I1 or I2 vary < 1%
I <sub>OVER</sub>	I1 or I2 overshoot on D/A Converter data byte transition			0	μA	DAC input byte changing from 00h to FFh and vice versa, V(I1) and V(I2) are Vcc-1.2V in source mode and 1.2V in sink mode. See note 3.
I <sub>UNDER</sub>	I1 or I2 undershoot on D/A Converter data byte transition			0	μA	
t <sub>rDAC</sub>	I1 or I2 rise time on D/A Converter data byte transition; 10% to 90%	5		30	μs	
TCO <sub>I1I2</sub>	Temperataure coefficient of output current I1 or I2 when using internal resistor setting		±200		ppm/°C	See Figure 5. Bits I1FSO[1:0] ≠ 00 <sub>2</sub> or Bits I2FSO[1:0] ≠ 00 <sub>2</sub> , VRMbit = “1”

- Notes:**
1. LSB is defined as  $\left[ \frac{2}{3} \times \frac{V(VRef)}{255} \right]$  divided by the resistance between R1 or R2 to Vss.
  2. Offset<sub>DAC</sub>: The Offset of a DAC is defined as the deviation between the measured and ideal output, when the DAC input is 01h. It is expressed in LSB.  
 FSError<sub>DAC</sub>: The Full Scale Error of a DAC is defined as the deviation between the measured and ideal output, when the input is FFh. It is expressed in LSB. The Offset<sub>DAC</sub> is subtracted from the measured value before calculating FSError<sub>DAC</sub>.  
 DNL<sub>DAC</sub>: The Differential Non-Linearity of a DAC is defined as the deviation between the measured and ideal incremental change in the output of the DAC, when the input changes by one code step. It is expressed in LSB. The measured values are adjusted for Offset and Full Scale Error before calculating DNL<sub>DAC</sub>.  
 INL<sub>DAC</sub>: The Integral Non-Linearity of a DAC is defined as the deviation between the measured and ideal transfer curves, after adjusting the measured transfer curve for Offset and Full Scale Error. It is expressed in LSB.
  3. These parameters are periodically sampled and not 100% tested.

## A/D CONVERTER CHARACTERISTICS

All typical values are for 25°C ambient temperature and 5 V at pin Vcc. Maximum and minimum specifications are over the recommended operating conditions. All voltages are referred to the voltage at pin Vss unless otherwise specified. All bits in control registers are “0” unless otherwise specified. 510Ω, 0.1%, resistor connected between R1 and Vss, and another between R2 and Vss unless otherwise specified. 400kHz TTL input at SCL unless otherwise specified. SDA pulled to Vcc through an external 2KΩ resistor unless otherwise specified. 2-wire interface in “standby” (see notes 1 and 2 on page 22), unless otherwise specified.  $\overline{WP}$ , A0, A1, and A2 floating unless otherwise specified.

Symbol	Parameter	Min	Typ	Max	Unit	Test Conditions / Notes
ADCTIME	A/D converter conversion time			9	ms	Proportional to A/D converter input voltage. This value is maximum at full scale input of A/D converter. ADCfiltOff = “1”
RIN <sub>ADC</sub>	VSense pin input resistance	100			kΩ	VSense as an input, ADCIN bit = “1”
CIN <sub>ADC</sub>	VSense pin input capacitance	1		7	pF	VSense as an input, ADCIN bit = “1”, Frequency = 1 MHz See note 3.
VIN <sub>ADC</sub>	VSense input signal range	0		V(VRef)	V	This is the A/D Converter Dynamic Range. ADCIN bit = “1”
Offset <sub>ADC</sub>	A/D converter offset error	-0.25		0.25	LSB	See notes 1 and 2
FSError <sub>ADC</sub>	A/D converter full scale error	-1		1	LSB	
DNL <sub>ADC</sub>	A/D Converter Differential Nonlinearity	-0.5		0.5	LSB	
INL <sub>ADC</sub>	A/D converter Integral Nonlinearity	-0.5		0.5	LSB	
TempStep <sub>ADC</sub>	Temperature step causing one step increment of ADC output	2.1	2.2	2.3	°C	
Out25 <sub>ADC</sub>	ADC output at 25°C		011101 <sub>2</sub>			

- Notes:**
- “LSB” is defined as V(VRef)/63, “Full Scale” is defined as V(VRef).
  - Offset<sub>ADC</sub>: For an ideal converter, the first transition of its transfer curve occurs at  $\left[ \frac{3^{1/2} \times V(VRef)}{255} \right]$  above zero. Offset error is the amount of deviation between the measured first transition point and the ideal point.  
 FSError<sub>ADC</sub>: For an ideal converter, the last transition of its transfer curve occurs at  $\left[ \frac{251^{1/2} \times V(VRef)}{255} \right]$ . Full Scale Error is the amount of deviation between the measured last transition point and the ideal point, after subtracting the Offset from the measured curve.  
 DNL<sub>ADC</sub>: DNL is defined as the difference between the ideal and the measured code transitions for successive A/D code outputs expressed in LSBs. The measured transfer curve is adjusted for Offset and Fullscale errors before calculating DNL.  
 INL<sub>ADC</sub>: The deviation of the measured transfer function of an A/D converter from the ideal transfer function. The INL error is also defined as the sum of the DNL errors starting from code 00h to the code where the INL measurement is desired. The measured transfer curve is adjusted for Offset and Fullscale errors before calculating INL.
  - These parameters are periodically sampled and not 100% tested.

# X9530

## 2-WIRE INTERFACE A.C. CHARACTERISTICS

Symbol	Parameter	Min	Typ	Max	Units	Test Conditions / Notes
$f_{SCL}$	SCL Clock Frequency	1 <sup>(3)</sup>		400	kHz	See "2-Wire Interface Test Conditions" (below),  See Figure 22, Figure 23 and Figure 24.
$t_{IN}^{(4)}$	Pulse width Suppression Time at inputs			50	ns	
$t_{AA}^{(4)}$	SCL Low to SDA Data Out Valid			900	ns	
$t_{BUF}^{(4)}$	Time the bus free before start of new transmission	1300			ns	
$t_{LOW}$	Clock Low Time	1.3		1200 <sup>(3)</sup>	$\mu$ s	
$t_{HIGH}$	Clock High Time	0.6		1200 <sup>(3)</sup>	$\mu$ s	
$t_{SU:STA}$	Start Condition Setup Time	600			ns	
$t_{HD:STA}$	Start Condition Hold Time	600			ns	
$t_{SU:DAT}$	Data In Setup Time	100			ns	
$t_{HD:DAT}$	Data In Hold Time	0			$\mu$ s	
$t_{SU:STO}$	Stop Condition Setup Time	600			ns	
$t_{DH}$	Data Output Hold Time	50			ns	
$t_R^{(4)}$	SDA and SCL Rise Time	20 +0.1Cb <sup>(1)</sup>		300	ns	
$t_F^{(4)}$	SDA and SCL Fall Time	20 +0.1Cb <sup>(1)</sup>		300	ns	
$t_{SU:WP}^{(4)}$	$\overline{WP}$ Setup Time	600			ns	
$t_{HD:WP}^{(4)}$	$\overline{WP}$ Hold Time	600			ns	
$C_b^{(4)}$	Capacitive load for each bus line			400	pF	

## 2-WIRE INTERFACE TEST CONDITIONS

Input Pulse Levels	10 % to 90 % of Vcc
Input Rise and Fall Times, between 10% and 90%	10 ns
Input and Output Timing Threshold Level	1.4V
External Load at pin SDA	2.3 k $\Omega$ to Vcc and 100 pF to Vss

## NONVOLATILE WRITE CYCLE TIMING

Symbol	Parameter	Min	Typ	Max	Units	Test Conditions / Notes
$t_{WC}^{(2)}$	Nonvolatile Write Cycle Time		5	10	ms	See Figure 24

- Notes:**
1. Cb = total capacitance of one bus line (SDA or SCL) in pF.
  2.  $t_{WC}$  is the time from a valid STOP condition at the end of a write sequence to the end of the self-timed internal nonvolatile write cycle. It is the minimum cycle time to be allowed for any nonvolatile write by the user, unless Acknowledge Polling is used.
  3. The minimum frequency requirement applies between a START and a STOP condition.
  4. These parameters are periodically sampled and not 100% tested.

TIMING DIAGRAMS

Figure 22. Bus Timing

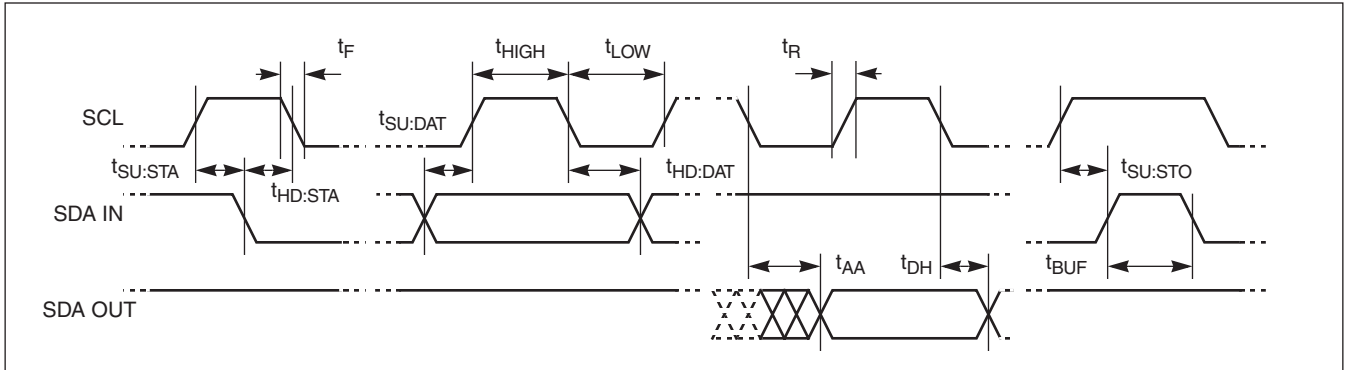

Figure 23. WP Pin Timing

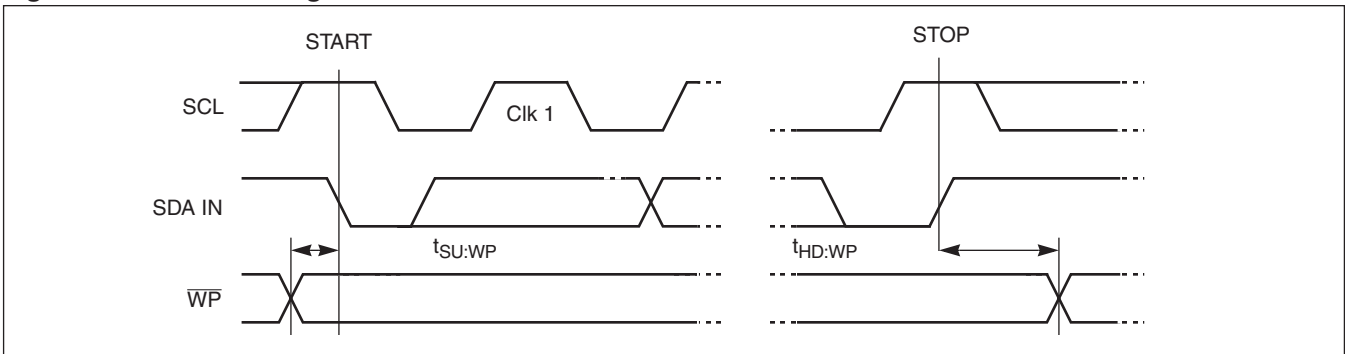
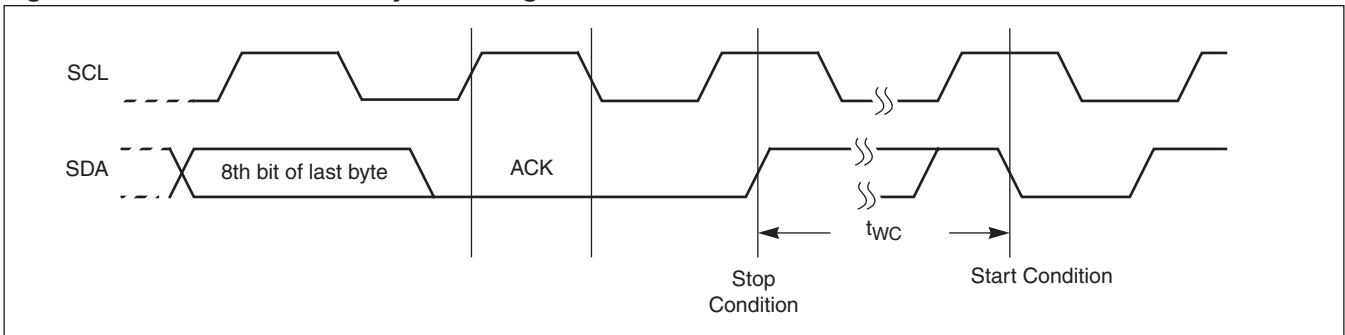
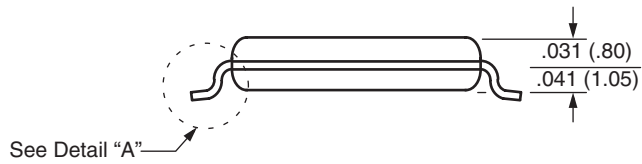
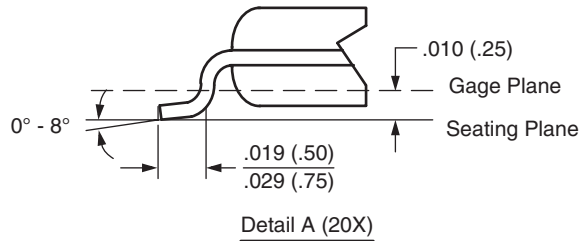
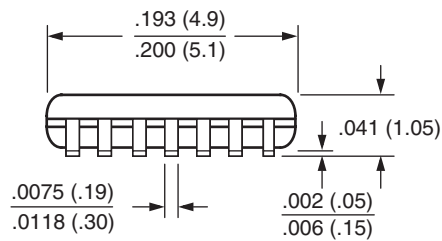
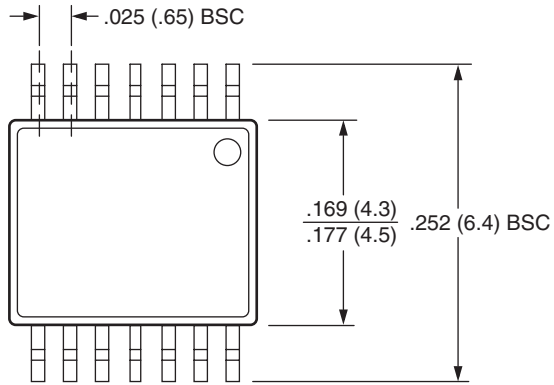

Figure 24. Non-Volatile Write Cycle Timing



14-Lead Plastic, TSSOP, Package Code V14



NOTE: ALL DIMENSIONS IN INCHES (IN PARENTHESES IN MILLIMETERS)

# X9530

## 15-Bump Chip Scale Package (CSP B15) Package Outline Drawing

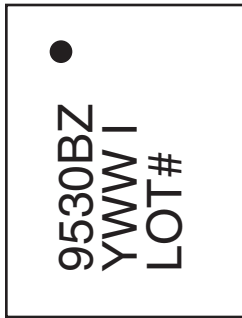

Top View (Marking Side)

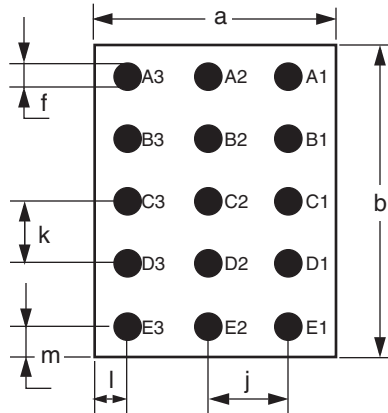

Bottom View (Bumped Side)

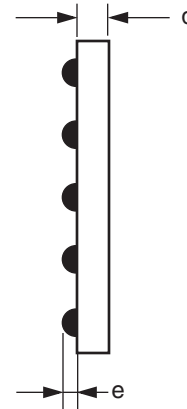

Side View



Side View

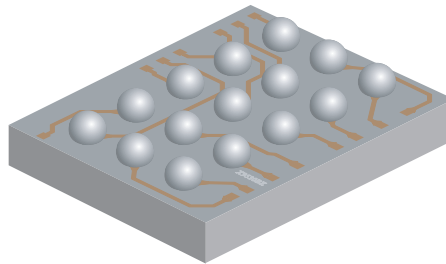

### Package Dimension

	Symbol	Millimeters		
		Min	Nominal	Max
Package Width	a	2.661	2.691	2.721
Package Length	b	3.474	3.504	3.534
Package Height	c	0.644	0.677	0.710
Body Thickness	d	0.444	0.457	0.470
Ball Height	e	0.220	0.240	0.260
Ball Diameter	f	0.310	0.330	0.350
Ball Pitch - Width	j		0.65	
Ball Pitch - Length	k		0.65	
Ball to Edge Spacing - Width	l	0.671	0.696	0.721
Ball to Edge Spacing - Length	m	0.427	0.452	0.477

### Ball Matrix:

	3	2	1
A	A0	I2	VRef
B	Vcc	A1	VSense
C	SCL	A2	Vss
D	SDA	Vss	R2
E	WP	I1	R1

# X9530

## ORDERING INFORMATION

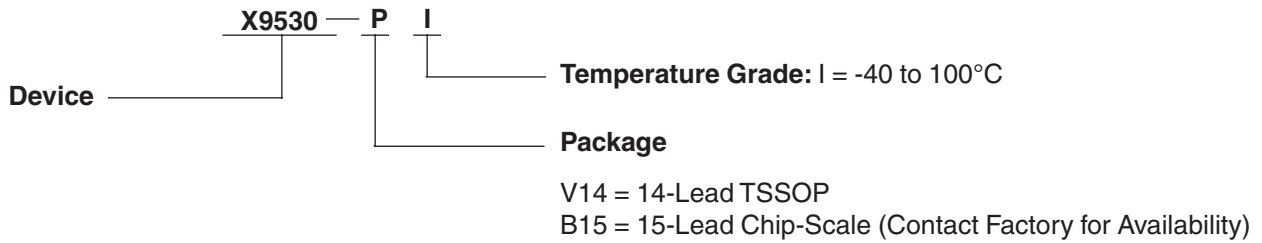

## ORDERING CODES

X9530V14I or X9530B15I

X9530B15I is offered only in  
Tape and Reel

X9530B15I-T1 2500 pcs reel  
X9530B15I-T2 1000 pcs reel

## LIMITED WARRANTY

©Xicor, Inc. 2003 Patents Pending

Devices sold by Xicor, Inc. are covered by the warranty and patent indemnification provisions appearing in its Terms of Sale only. Xicor, Inc. makes no warranty, express, statutory, implied, or by description regarding the information set forth herein or regarding the freedom of the described devices from patent infringement. Xicor, Inc. makes no warranty of merchantability or fitness for any purpose. Xicor, Inc. reserves the right to discontinue production and change specifications and prices at any time and without notice.

Xicor, Inc. assumes no responsibility for the use of any circuitry other than circuitry embodied in a Xicor, Inc. product. No other circuits, patents, or licenses are implied.

## TRADEMARK DISCLAIMER:

Xicor and the Xicor logo are registered trademarks of Xicor, Inc. AutoStore, Direct Write, Block Lock, SerialFlash, MPS, and XDCP are also trademarks of Xicor, Inc. All others belong to their respective owners.

## U.S. PATENTS

Xicor products are covered by one or more of the following U.S. Patents: 4,326,134; 4,393,481; 4,404,475; 4,450,402; 4,486,769; 4,488,060; 4,520,461; 4,533,846; 4,599,706; 4,617,652; 4,668,932; 4,752,912; 4,829,482; 4,874,967; 4,883,976; 4,980,859; 5,012,132; 5,003,197; 5,023,694; 5,084,667; 5,153,880; 5,153,691; 5,161,137; 5,219,774; 5,270,927; 5,324,676; 5,434,396; 5,544,103; 5,587,573; 5,835,409; 5,977,585. Foreign patents and additional patents pending.

## LIFE RELATED POLICY

In situations where semiconductor component failure may endanger life, system designers using this product should design the system with appropriate error detection and correction, redundancy and back-up features to prevent such an occurrence.

Xicor's products are not authorized for use in critical components in life support devices or systems.

1. Life support devices or systems are devices or systems which, (a) are intended for surgical implant into the body, or (b) support or sustain life, and whose failure to perform, when properly used in accordance with instructions for use provided in the labeling, can be reasonably expected to result in a significant injury to the user.
2. A critical component is any component of a life support device or system whose failure to perform can be reasonably expected to cause the failure of the life support device or system, or to affect its safety or effectiveness.