

**Document Title**

**512MBit (4Bank x 8M x 16bits) MOBILE DDR SDRAM Memory**

**Revision History**

| Revision No. | History                    | Draft Date | Remark      |
|--------------|----------------------------|------------|-------------|
| 0.1          | Initial Draft              | Jun.2005   | Preliminary |
| 0.2          | Defined DC Characteristics | Aug.2006   | Preliminary |

## FEATURES SUMMARY

### ● Mobile DDR SDRAM MEMORIES

- Double data rate architecture  
: two data transfers per clock cycle

### ● Mobile DDR SDRAMs INTERFACE

- x16 bus width : HY5MS7B6ALFP
- Multiplexed Address/ Data
- Pinout compatibility for all densities

### ● SUPPLY VOLTAGE

- 1.8V device: VDD = 1.7 to 1.95V

### ● MEMORY CELL ARRAY

- 512Mbit (x16 device) = 8M x 4Bank x 16 I/O

### ● DATA STROBE (Bidirectional)

- x16 device: All Bank(4 Bank) Operation  
(with single pulsed  $\overline{\text{RAS}}$ )
- All addresses and control inputs except data, data strobes and data masks latched on the rising edges of the clock

### ● LOW POWER FEATURES

- PASR (Partial Array Self Refresh)
- AUTO TCSR (Temperature Compensated Self Refresh)
- DS (Drive Strength)
- Deep Power Down Mode

### ● INPUT CLOCK

- Fully differential clock inputs (CK,  $\overline{\text{CK}}$ ) operation

### ● Data MASK

- UDM, LDM : Input mask signal for write data
- DM mask write data-in at the both rising and falling edges of the data strobe

### ● MODE REGISTER SET AND EXTENDED MODE REGISTER SET

- Keep to the JEDEC Standard regulation  
(Low Power DDR)

### ● CAS LATENCY (Programmable)

- Programmable CAS latency 3 or 2 supported

### ● BURST LENGTH

- Programmable burst length 2 / 4 / 8 / 16 with both sequential and interleave mode

### ● AUTO PRECHARGE

- Option for each burst access

### ● AUTO REFRESH AND SELF REFRESH MODE

### ● CLOCK STOP MODE

- Clock stop mode is a feature supported by Mobile DDR SDRAM devices.
- Keep to the JEDEC Standard regulation

### ● *INITIALIZING THE MOBILE DDR SDRAMs*

- Occur at device power up or interruption of device power.

### ● PACKAGE - *60Ball FBGA*

- HY5MS7B6ALFP : Lead free FBGA

## DESCRIPTION

The Hynix Mobile DDR SDRAMs is suited for non-PC application which use the batteries such as PDAs, 2.5G and 3G cellular phones with internet access and multimedia capabilities, mini-notebook, handheld PCs.

The Hynix HY5MS7B6LF(P) Series is 536,870,912-bit CMOS Low Power Double Data Rate Synchronous DRAM(Mobile DDR), ideally suited for the main memory applications which requires large memory density and high bandwidth. It is organized as 4banks of 8,388,608x16.

The HYNIX HY5MS7B6LF(P) Low power Double Data Rate SDRAM(Mobile DDR) uses a double-data-rate architecture to achieve high-speed operation. The address lines are multiplexed with the Data Input/ Output signals on a multiplexed x16 Input/ Output bus. The double data rate architecture is essentially a  $2n$  prefetch architecture with an interface designed to transfer two data words per clock cycle at the I/O pins. This interface reduces the pin count and makes it possible to migrate to other densities without changing the footprint.

The Hynix HY5MS7B6LF(P) Series Low power DDR SDRAMs(Mobile DDR) offer fully synchronous operations referenced to both rising and falling edges of the clock. While all addresses and control inputs are latched on the rising edges of the CK (The Mobile DDR operates from a differential clock : *the crossing of CK going HIGH and  $\overline{CK}$  going LOW is referred to as the positive edge of CK*), Data, Data strobes and Write data masks inputs are sampled on both rising and falling edges of it (*Input data is registered on both edges of DQS, and output data is referenced to both edges of DQS, as well as to both edges of CK*). The data paths are internally pipelined and 2-bit prefetched to achieve very high bandwidth. All input and output voltage levels are compatible with Interface of Low Power DDR SDRAM(Mobile DDR) Device.

Read and write accesses to the Low Power DDR SDRAMs(Mobile DDR) are burst oriented; accesses start at a selected location and continue for a programmed number of locations in a programmed sequence. Accesses begin with the registration of an ACTIVE command, which is then followed by a READ or WRITE command. The address bits registered coincident with the ACTIVE command are used to select the bank and the row to be accessed. The address bits registered coincident with the READ or WRITE command are used to select the bank and the starting column location for the burst access.

The Low Power DDR SDRAMs(Mobile DDR) provides for programmable read or write bursts of 2, 4 or 8 locations. An AUTO PRECHARGE function may be enabled to provide a self-timed row precharge that is initiated at the end of the burst access.

As with standard SDRAMs, the pipe lined, multibank architecture of Low Power DDR SDRAMs(Mobile DDR) allows for concurrent operation, thereby providing high effective bandwidth by hiding row precharge and activation times.

And the Low Power DDR SDRAMs(Mobile DDR) also provides for special programmable options including Partial Array Self Refresh of full array, half array, quarter array, 1/8 array and 1/16 array, Temperature Compensated Self Refresh of 15, 45, 70 or 85 degrees °C. A burst of Read or Write cycles in progress can be terminated by a burst terminate command or can be interrupted and replaced by a new burst Read or Write command on any cycle(This pipelined design is not restricted by a 2N rule).

The Hynix HY5MS7B6LF(P) has the special Low Power function of Auto TCSR(Temperature Compensated Self Refresh) to reduce self refresh current consumption. Since an internal temperature sensor is implanted, it enables to automatically adjust refresh rate according to temperature without external EMRS command.

Deep Power Down Mode is a additional operating mode for Low Power DDR SDRAMs(Mobile DDR). This mode can achieve maximum power reduction by removing power to the memory array within each DDR SDRAMs. By using this feature, the system can cut off almost all DRAM power without adding the cost of a power switch and giving up mother-board power-line layout flexibility.

All inputs are LV-CMOS compatible. Devices will have a VDD and VDDQ supply of 1.8V (nominal).

The devices are available in the following packages:

- **60Ball FBGA**

#### 512M Mobile DDR ORDERING INFORMATION

| Part Number   | Clock Frequency  | CAS Latency | Organization      | Interface | Package   |
|---------------|------------------|-------------|-------------------|-----------|-----------|
| HY5MS7B6LF-6  | DDR333<br>166MHz | 3           | 4banks x 8Mb x 16 | LVCMOS    | Lead      |
| HY5MS7B6LF-H  | DDR266<br>133MHz | 3           |                   |           |           |
| HY5MS7B6LF-S  | DDR200<br>100MHz | 3           |                   |           |           |
| HY5MS7B6LFP-6 | DDR333<br>166MHz | 3           |                   |           | Lead Free |
| HY5MS7B6LFP-H | DDR266<br>133MHz | 3           |                   |           |           |
| HY5MS7B6LFP-S | DDR200<br>100MHz | 3           |                   |           |           |

Notice : **Clock Frequency DDR333 / 166MHz Product** : - *Contact Hynix Office for product availability.*

### FBGA 60Ball ASSIGNMENT

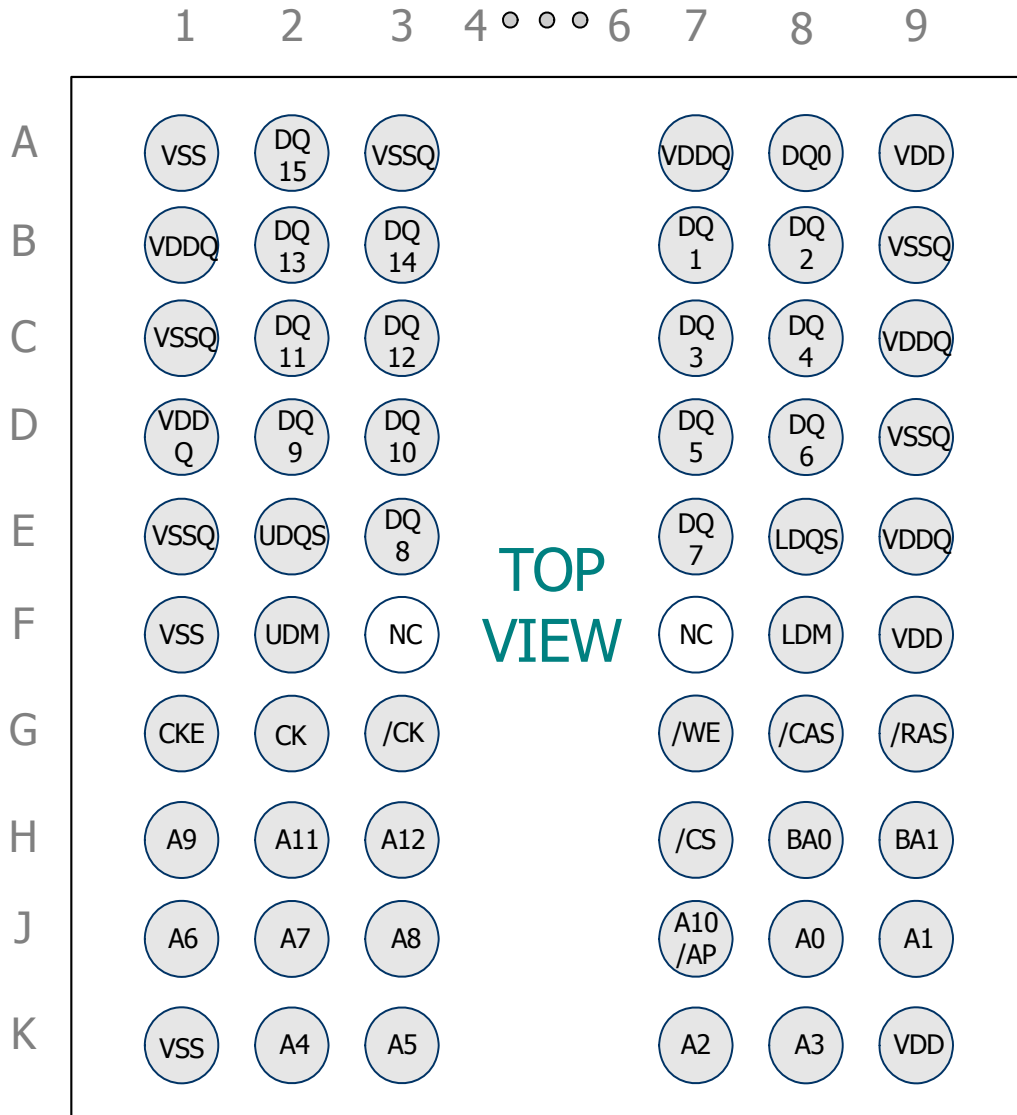

## Mobile DDR PAD FUNCTION DESCRIPTIONS(I)

| SYMBOL  | TYPE  | DESCRIPTION  |
|---|-------|--|
| CK, $\overline{CK}$                                   | INPUT | Clock: CK and $\overline{CK}$ are differential clock inputs. All address and control input signals are sampled on the crossing of the positive edge of CK and negative edge of $\overline{CK}$ . Output (read) data is referenced to the crossings of CK and $\overline{CK}$ (both directions of crossing).  |
| CKE   | INPUT | Clock Enable: CKE HIGH activates, and CKE LOW deactivates internal clock signals, and device input buffers and output drivers. Taking CKE LOW provides PRECHARGE POWER-DOWN and SELF REFRESH operation (all banks idle), or ACTIVE POWER-DOWN (row ACTIVE in any bank). CKE is synchronous for all functions except for SELF REFRESH EXIT, which is achieved asynchronously.   |
| $\overline{CS}$                                       | INPUT | Chip Select : Enables or disables all inputs except CLK, CKE, UDQM and LDQM. $\overline{CS}$ enables (registered LOW) and disables (registered HIGH) the command decoder. All commands are masked when $\overline{CS}$ is registered HIGH. $\overline{CS}$ provides for external bank selection on systems with multiple banks. $\overline{CS}$ is considered part of the command code.  |
| BA0, BA1  | INPUT | Bank Address Inputs :<br>BA0 and BA1 define to which bank an ACTIVE, READ, WRITE or PRECHARGE command is being applied. BA0 and BA1 also determine which mode register is to be loaded during a MODE REGISTER SET command (MRS or EMRS).   |
| A0 ~ A12  | INPUT | Row Address : RA0 ~ RA12, Column Address : CA0 ~ CA9<br>Auto-precharge flag : A10/AP<br>Provide the row address for ACTIVE commands, and the column address and AUTO PRECHARGE bit for READ/WRITE commands, to select one location out of the memory array in the respective bank. A10 sampled during a PRECHARGE command determines whether the PRECHARGE applies to one bank (A10 LOW) or all banks (A10 HIGH). If only one bank is to be precharged, the bank is selected by BA0, BA1. The address inputs also provide the op-code during a MODE REGISTER SET command. BA0 and BA1 determines which mode register ( Mode Register or Extended Mode Register ) is loaded during the MODE REGISTER SET command. |
| $\overline{RAS}$ , $\overline{CAS}$ , $\overline{WE}$ | INPUT | Command Inputs : $\overline{RAS}$ , $\overline{CAS}$ and $\overline{WE}$ define the operation<br>Refer function truth table for details  |
| UDM, LDM  | INPUT | Input Data Mask: DM is an input mask signal for write data.<br>Data Mask is an input mask signal for write data. Input data is masked when Data Mask is sampled. HIGH along with that input data during a WRITE access. Data Mask is sampled on both edges of DQS. Data Mask pins include dummy loading internally, to match the DQ and DQS loading. LDM corresponds to the data on DQ0-DQ7 ; UDM corresponds to the data on DQ8-DQ15  |
| LDQS, UDQS  | I/O   | Data Strobe: Output with read data, input with write data. Edge aligned with read data, centered in write data. Used to capture write data. For the x16, LDQS corresponds to the data on DQ0-Q7; UDQS corresponds to the data on DQ8-Q15.  |

## Mobile DDR PAD FUNCTION DESCRIPTIONS (II)

| SYMBOL     | TYPE   | DESCRIPTION   |
|------------|--------|---|
| DQ0 ~ DQ15 | I/O    | Data Input/Output : Multiplexed data input/output pin |
| VDD        | SUPPLY | Power supply  |
| VSS        | SUPPLY | Ground  |
| VDDQ       | SUPPLY | I/O Power supply                                      |
| VSSQ       | SUPPLY | I/O Ground  |
| NC         | -      | No connection : These pads should be left unconnected |

**FUNCTIONAL BLOCK DIAGRAM**  
 8Mbit x 4banks x 16 I/O Mobile DDR SDRAM

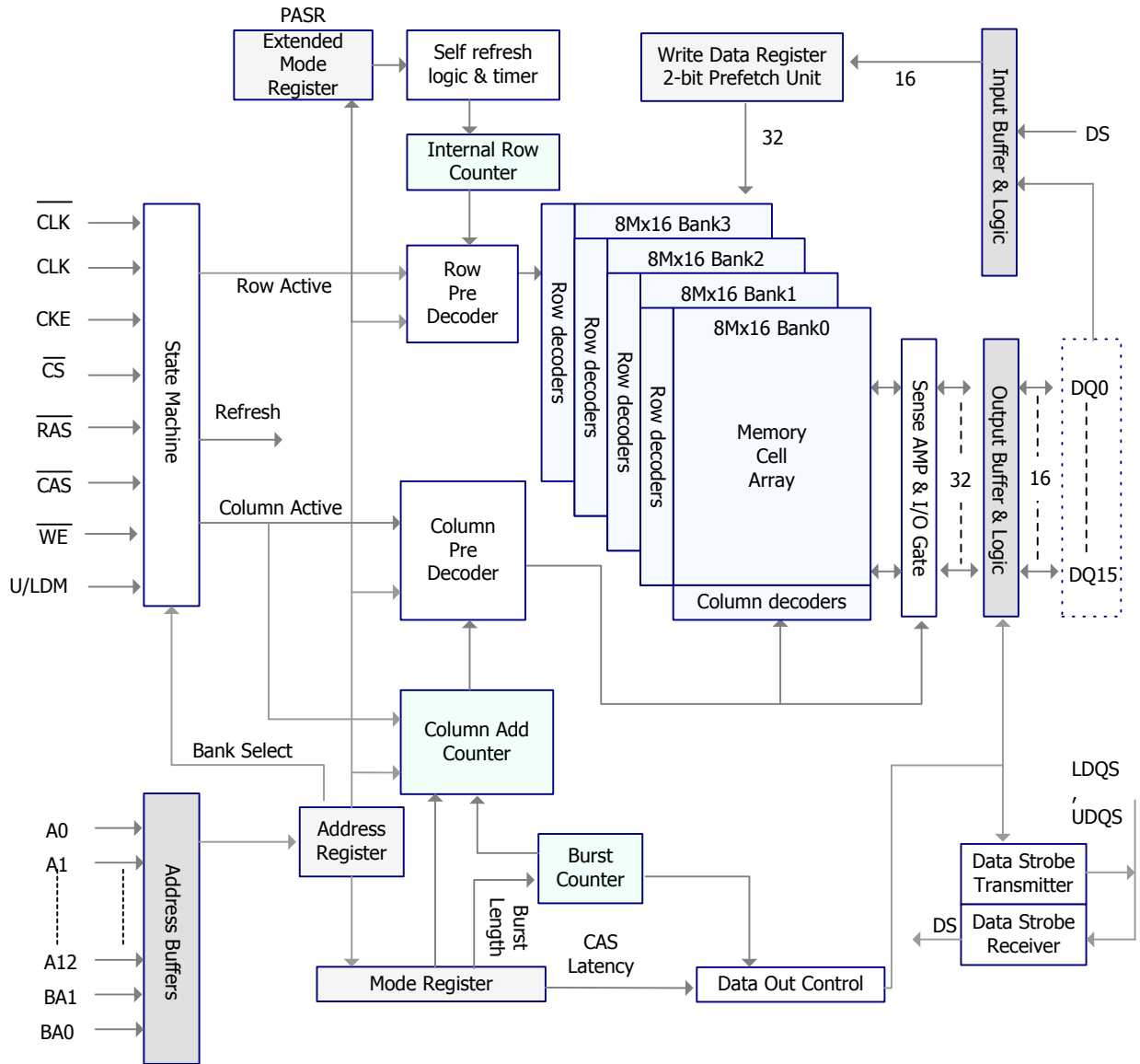

## BASIC FUNCTIONAL DESCRIPTION

### Mode Register Set(MRS) for Mobile DDR SDRAM

| BA1 | BA0 | A12 | A11 | A10 | A9 | A8 | A7 | A6          | A5 | A4 | A3 | A2           | A1 | A0 |
|-----|-----|-----|-----|-----|----|----|----|-------------|----|----|----|--------------|----|----|
| 0   | 0   | 0   | 0   | 0   | 0  | 0  | 0  | CAS Latency |    |    | BT | Burst Length |    |    |

**Burst Type**

| A3 | Burst Type |
|----|------------|
| 0  | Sequential |
| 1  | Interleave |

**CAS Latency**

| A6 | A5 | A4 | CAS Latency |
|----|----|----|-------------|
| 0  | 0  | 0  | Reserved    |
| 0  | 0  | 1  | Reserved    |
| 0  | 1  | 0  | 2           |
| 0  | 1  | 1  | 3           |
| 1  | 0  | 0  | Reserved    |
| 1  | 0  | 1  | Reserved    |
| 1  | 1  | 0  | Reserved    |
| 1  | 1  | 1  | Reserved    |

**Burst Length**

| A2 | A1 | A0 | Burst Length |          |
|----|----|----|--------------|----------|
|    |    |    | A3 = 0       | A3 = 1   |
| 0  | 0  | 0  | Reserved     | Reserved |
| 0  | 0  | 1  | 2            | 2        |
| 0  | 1  | 0  | 4            | 4        |
| 0  | 1  | 1  | 8            | 8        |
| 1  | 0  | 0  | Reserved     | Reserved |
| 1  | 0  | 1  | Reserved     | Reserved |
| 1  | 1  | 0  | Reserved     | Reserved |
| 1  | 1  | 1  | Reserved     | Reserved |

## BASIC FUNCTIONAL DESCRIPTION (Continued)

### Extended Mode Register Set(EMRS) for Mobile DDR SDRAM

| BA1 | BA0 | A12 | A11 | A10 | A9 | A8 | A7 | A6 | A5 | A4 | A3 | A2   | A1 | A0 |
|-----|-----|-----|-----|-----|----|----|----|----|----|----|----|------|----|----|
| 1   | 0   | 0   | 0   | 0   | 0  | 0  | 0  | DS |    | 0  | 0  | PASR |    |    |

DS (Drive Strength)

| A6 | A5 | Driver Strength |
|----|----|-----------------|
| 0  | 0  | Full            |
| 0  | 1  | 1/2 Strength    |
| 1  | 0  | 1/4 Strength    |
| 1  | 1  | 1/8 Strength    |

PASR (Partial Array Self Refresh)

| A2 | A1 | A0 | Self Refresh Coverage   |
|----|----|----|---|
| 0  | 0  | 0  | All Banks   |
| 0  | 0  | 1  | Half of Total Bank (BA1=0)  |
| 0  | 1  | 0  | Quarter of Total Bank (BA1=BA0=0)                                 |
| 0  | 1  | 1  | Reserved  |
| 1  | 0  | 0  | Reserved  |
| 1  | 0  | 1  | One Eighth of Total Bank<br>(BA1 = BA0 = Row Address MSB=0)       |
| 1  | 1  | 0  | One Sixteenth of Total Bank<br>(BA1 = BA0 = Row Address 2 MSBs=0) |
| 1  | 1  | 1  | Reserved  |

## COMMAND TRUTH TABLE

| Function   | $\overline{CS}$ | $\overline{RAS}$ | $\overline{CAS}$ | $\overline{WE}$ | BA | A10/AP  | ADDR | Note  |
|--|-----------------|------------------|------------------|-----------------|----|---------|------|-------|
| DESELECT (NOP)                                       | H               | X                | X                | X               | X  | X       | X    | 2     |
| NO OPERATION (NOP)                                   | L               | H                | H                | H               | X  | X       | X    | 2     |
| ACTIVE (Select Bank and activate Row)                | L               | L                | H                | H               | V  | Row     | Row  |       |
| READ (Select bank and column and start read burst)   | L               | H                | L                | H               | V  | L       | Col  |       |
| READ with AP (Read Burst with Autoprecharge)         | L               | H                | L                | H               | V  | H       | Col  | 3     |
| WRITE (Select bank and column and start write burst) | L               | H                | L                | L               | V  | L       | Col  |       |
| WRITE with AP (Write Burst with Autoprecharge)       | L               | H                | L                | L               | V  | H       | Col  | 3     |
| BURST TERMINATE or enter DEEP POWER DOWN             | L               | H                | H                | L               | X  | X       | X    | 4, 5  |
| PRECHARGE (Deactivate Row in selected bank)          | L               | L                | H                | L               | V  | L       | X    | 6     |
| PRECHARGE ALL (Deactivate rows in all Banks)         | L               | L                | H                | L               | X  | H       | X    | 6     |
| AUTO REFRESH or enter SELF REFRESH                   | L               | L                | L                | H               | X  | X       | X    | 7,8,9 |
| MODE REGISTER SET                                    | L               | L                | L                | L               | V  | Op_Code |      | 10    |

## DM TRUTH TABLE

| Function      | DM | DQ    | Note |
|---------------|----|-------|------|
| Write Enable  | L  | Valid | 11   |
| Write Inhibit | H  | X     | 11   |

Note:

1. All states and sequences not shown are illegal or reserved.
2. Deselect and NOP are functionally interchangeable.
3. Autoprecharge is non-persistent. A10 High enables Autoprecharge, while A10 Low disables Autoprecharge
4. Burst Terminate applies to only Read bursts with autoprecharge disabled.  
This command is undefined and should not be used for Read with Autoprecharge enabled, and for Write bursts.
5. This command is BURST TERMINATE if CKE is High and DEEP POWER DOWN entry if CKE is Low.
6. If A10 is low, bank address determines which bank is to be precharged. If A10 is high, all banks are precharged and BA0-BA1 are don't care.
7. This command is AUTO REFRESH if CKE is High, and SELF REFRESH if CKE is low.
8. All address inputs and I/O are "don't care" except for CKE. Internal refresh counters control Bank and Row addressing.
9. All banks must be precharged before issuing an AUTO-REFRESH or SELF REFRESH command.
10. BA0 and BA1 value select between MRS and EMRS.
11. Used to mask write data, provided coincident with the corresponding data.
12. CKE is HIGH for all commands shown except SELF REFRESH and DEEP POWER-DOWN.

## CKE TRUTH TABLE

| CKEn-1 | CKEn | Current State              | COMMAND $n$     | ACTION $n$                 | Note   |
|--------|------|----------------------------|-----------------|----------------------------|--------|
| L      | L    | Power Down                 | X               | Maintain Power Down        |        |
| L      | L    | Self Refresh               | X               | Maintain Self Refresh      |        |
| L      | L    | Deep Power Down            | X               | Maintain Deep Power Down   |        |
| L      | H    | Power Down                 | NOP or DESELECT | Exit Power Down            | 5,6,9  |
| L      | H    | Self Refresh               | NOP or DESELECT | Exit Self Refresh          | 5,7,10 |
| L      | H    | Deep Power Down            | NOP or DESELECT | Exit Deep Power Down       | 5,8    |
| H      | L    | All Banks Idle             | NOP or DESELECT | Precharge Power Down Entry | 5      |
| H      | L    | Bank(s) Active             | NOP or DESELECT | Active Power Down Entry    | 5      |
| H      | L    | All Banks Idle             | AUTO REFRESH    | Self Refresh entry         |        |
| H      | L    | All Banks Idle             | BURST TERMINATE | Enter Deep Power Down      |        |
| H      | H    | See the other Truth Tables |                 |                            |        |

Note:

1. CKEn is the logic state of CKE at clock edge  $n$ ; CKEn-1 was the state of CKE at the previous clock edge.
2. Current state is the state of LP DDR immediately prior to clock edge  $n$ .
3. COMMAND $n$  is the command registered at clock edge  $n$ , and ACTION $n$  is the result of COMMAND $n$ .
4. All states and sequences not shown are illegal or reserved.
5. DESELECT and NOP are functionally interchangeable.
6. Power Down exit time (tXP) should elapse before a command other than NOP or DESELECT is issued.
7. SELF REFRESH exit time (tXSR) should elapse before a command other than NOP or DESELECT is issued.
8. The Deep Power-Down exit procedure must be followed as discussed in the Deep Power-Down section of the Functional Description.
9. The clock must toggle at least one time during the tXP period.
10. The clock must toggle at least once during the tXSR time.

**CURRENT STATE BANK $n$  TRUTH TABLE** (COMMAND TO BANK  $n$ )

| Current State                     | Command |     |     |    |                   | Action                                 | Notes  |
|-----------------------------------|---------|-----|-----|----|-------------------|--|--------|
|                                   | CS      | RAS | CAS | WE | Description       |  |        |
| Any                               | H       | X   | X   | X  | DESELECT (NOP)    | Continue previous Operation            |        |
|                                   | L       | H   | H   | H  | NOP               | Continue previous Operation            |        |
| Idle                              | L       | L   | H   | H  | ACTIVE            | Select and activate row                |        |
|                                   | L       | L   | L   | H  | AUTO REFRESH      | Auto refresh                           | 10     |
|                                   | L       | L   | L   | L  | MODE REGISTER SET | Mode register set                      | 10     |
|                                   | L       | L   | H   | H  | PRECHARGE         | No action if bank is idle              |        |
| Row Active                        | L       | H   | L   | H  | READ              | Select Column & start read burst       |        |
|                                   | L       | H   | L   | L  | WRITE             | Select Column & start write burst      |        |
|                                   | L       | L   | H   | L  | PRECHARGE         | Deactivate Row in bank (or banks)      | 4      |
| Read<br>(without Auto recharge)   | L       | H   | L   | H  | READ              | Truncate Read & start new Read burst   | 5,6    |
|                                   | L       | H   | L   | L  | WRITE             | Truncate Read & start new Write burst  | 5,6,13 |
|                                   | L       | L   | H   | L  | PRECHARGE         | Truncate Read, start Precharge         |        |
|                                   | L       | H   | H   | L  | BURST TERMINATE   | Burst terminate                        | 11     |
| Write<br>(without Auto precharge) | L       | H   | L   | H  | READ              | Truncate Write & start new Read burst  | 5,6,12 |
|                                   | L       | H   | L   | L  | WRITE             | Truncate Write & start new Write burst | 5,6    |
|                                   | L       | L   | H   | L  | PRECHARGE         | Truncate Write, start Precharge        | 12     |

Note:

1. The table applies when both CKE $n-1$  and CKE $n$  are HIGH, and after tXSR or tXP has been met if the previous state was Self Refresh or Power Down.
2. Deselect and NOP are functionally interchangeable.
3. All states and sequences not shown are illegal or reserved.
4. This command may or may not be bank specific. If all banks are being precharged, they must be in a valid state for precharging.
5. A command other than NOP should not be issued to the same bank while a READ or WRITE Burst with auto precharge is enabled.
6. The new Read or Write command could be auto precharge enabled or auto precharge disabled.

7. Current State Definitions:

Idle: The bank has been precharged, and tRP has been met.

Row Active: A row in the bank has been activated, and tRCD has been met.

No data bursts/accesses and no register accesses are in progress.

Read: A READ burst has been initiated, with AUTO PRECHARGE disabled, and has not yet terminated or been terminated.

Write: a WRITE burst has been initiated, with AUTO PRECHARGE disabled, and has not yet terminated or been terminated.

8. The following states must not be interrupted by a command issued to the same bank.

DESELECT or NOP commands or allowable commands to the other bank should be issued on any clock edge occurring during these states. Allowable commands to the other bank are determined by its current state and Truth Table 3, and according to Truth Table 4.

Precharging: Starts with the registration of a PRECHARGE command and ends when tRP is met.

Once tRP is met, the bank will be in the idle state.

Row Activating: Starts with registration of an ACTIVE command and ends when tRCD is met.

Once tRCD is met, the bank will be in the "row active" state.

Read with AP Enabled: Starts with the registration of the READ command with AUTO PRECHARGE enabled and ends when tRP has been met. Once tRP has been met, the bank will be in the idle state.

Write with AP Enabled: Starts with registration of a WRITE command with AUTO PRECHARGE enabled and ends when tRP has been met. Once tRP is met, the bank will be in the idle state.

9. The following states must not be interrupted by any executable command; Deselect or NOP commands must be applied to each positive clock edge during these states.

Refreshing: Starts with registration of an AUTO REFRESH command and ends when tRFC is met.

Once tRFC is met, the LP DDR will be in an "all banks idle" state.

Accessing Mode Register: Starts with registration of a MODE REGISTER SET command and ends when tMRD has been met.

Once tMRD is met, the LP DDR will be in an "all banks idle" state.

Precharging All: Starts with the registration of a PRECHARGE ALL command and ends when tRP is met.

Once tRP is met, the bank will be in the idle state.

10. Not bank-specific; requires that all banks are idle and no bursts are in progress.

11. Not bank-specific. BURST TERMINATE affects the most recent READ burst, regardless of bank.

12. Requires appropriate DM masking.

13. A WRITE command may be applied after the completion of the READ burst; otherwise, a Burst terminate must be used to end the READ prior to asserting a WRITE command.

**CURRENT STATE BANK $n$  TRUTH TABLE** (COMMAND TO BANK  $m$ )

| Current State                                  | Command |     |     |    |                | Action                          | Notes  |
|--|---------|-----|-----|----|----------------|---------------------------------|--------|
|  | CS      | RAS | CAS | WE | Description    |                                 |        |
| Any  | H       | X   | X   | X  | DESELECT (NOP) | Continue previous Operation     |        |
|  | L       | H   | H   | H  | NOP            | Continue previous Operation     |        |
| Idle   | X       | X   | X   | X  | ANY            | Any command allowed to bank $m$ |        |
| Row Activating,<br>Active, or Pre-<br>charging | L       | L   | H   | H  | ACTIVE         | Activate Row                    |        |
|  | L       | H   | L   | H  | READ           | Start READ burst                | 8      |
|  | L       | H   | L   | L  | WRITE          | Start WRITE burst               | 8      |
|  | L       | L   | H   | L  | PRECHARGE      | Precharge                       |        |
| Read with Auto<br>Precharge dis-<br>abled      | L       | L   | H   | H  | ACTIVE         | Activate Row                    |        |
|  | L       | H   | L   | H  | READ           | Start READ burst                | 8      |
|  | L       | H   | L   | L  | WRITE          | Start WRITE burst               | 8,10   |
|  | L       | L   | H   | L  | PRECHARGE      | Precharge                       |        |
| Write with Auto<br>precharge dis-<br>abled     | L       | L   | H   | H  | ACTIVE         | Activate Row                    |        |
|  | L       | H   | L   | H  | READ           | Start READ burst                | 8,9    |
|  | L       | H   | L   | L  | WRITE          | Start WRITE burst               | 8      |
|  | L       | L   | H   | L  | PRECHARGE      | Precharge                       |        |
| Read with Auto<br>Precharge                    | L       | L   | H   | H  | ACTIVE         | Activate Row                    |        |
|  | L       | H   | L   | H  | READ           | Start READ burst                | 5,8    |
|  | L       | H   | L   | L  | WRITE          | Start WRITE burst               | 5,8,10 |
|  | L       | L   | H   | L  | PRECHARGE      | Precharge                       |        |
| Write with Auto<br>precharge                   | L       | L   | H   | H  | ACTIVE         | Activate Row                    |        |
|  | L       | H   | L   | H  | READ           | Start READ burst                | 5,8    |
|  | L       | H   | L   | L  | WRITE          | Start WRITE burst               | 5,8    |
|  | L       | L   | H   | L  | PRECHARGE      | Precharge                       |        |

Note:

1. The table applies when both  $CKE_{n-1}$  and  $CKE_n$  are HIGH, and after tXSR or tXP has been met if the previous state was Self Refresh or Power Down.
2. DESELECT and NOP are functionally interchangeable.
3. All states and sequences not shown are illegal or reserved.
4. Current State Definitions:
  - Idle: The bank has been precharged, and tRP has been met.
  - Row Active: A row in the bank has been activated, and tRCD has been met. No data bursts/accesses and no register accesses are in progress.
  - Read: A READ burst has been initiated, with AUTO PRECHARGE disabled, and has not yet terminated or been terminated.
  - Write: a WRITE burst has been initiated, with AUTO PRECHARGE disabled, and has not yet terminated or been terminated.
5. Read with AP enabled and Write with AP enabled: The read with Autoprecharge enabled or Write with Autoprecharge enabled states can be broken into two parts: the access period and the precharge period. For Read with AP, the precharge period is defined as if the same burst was executed with Auto Precharge disabled and then followed with the earliest possible PRECHARGE command that still accesses all the data in the burst. For Write with Auto precharge, the precharge period begins when tWR ends, with tWR measured as if Auto Precharge was disabled. The access period starts with registration of the command and ends where the precharge period (or tRP) begins. During the precharge period, of the Read with Autoprecharge enabled or Write with Autoprecharge enabled states, ACTIVE, PRECHARGE, READ, and WRITE commands to the other bank may be applied; during the access period, only ACTIVE and PRECHARGE commands to the other banks may be applied. In either case, all other related limitations apply (e.g. contention between READ data and WRITE data must be avoided).
6. AUTO REFRESH, SELF REFRESH, and MODE REGISTER SET commands may only be issued when all bank are idle.
7. A BURST TERMINATE command cannot be issued to another bank; it applies to the bank represented by the current state only.
8. READs or WRITEs listed in the Command column include READs and WRITEs with AUTO PRECHARGE enabled and READs and WRITEs with AUTO PRECHARGE disabled.
9. Requires appropriate DM masking.
10. A WRITE command may be applied after the completion of data output, otherwise a BURST TERMINATE command must be issued to end the READ prior to asserting a WRITE command.

## ABSOLUTE MAXIMUM RATING

| Parameter                          | Symbol    | Rating          | Unit |
|------------------------------------|-----------|-----------------|------|
| Ambient Temperature                | TA        | -25 ~ 85        | °C   |
| Storage Temperature                | TSTG      | -55 ~ 150       | °C   |
| Voltage on Any Pin relative to VSS | VIN, VOUT | -0.3 ~ VDDQ+0.3 | V    |
| Voltage on VDD relative to VSS     | VDD       | -0.3 ~ 2.7      | V    |
| Voltage on VDDQ relative to VSS    | VDDQ      | -0.3 ~ 2.7      | V    |
| Short Circuit Output Current       | IOS       | 50              | mA   |
| Power Dissipation                  | PD        | 0.7             | W    |

## DC OPERATING CONDITION (TA= -25 to 85°C )

| Parameter            | Symbol | Min | Typ | Max  | Unit | Note |
|----------------------|--------|-----|-----|------|------|------|
| Power Supply Voltage | VDD    | 1.7 | 1.8 | 1.95 | V    | 1    |
| Power Supply Voltage | VDDQ   | 1.7 | 1.8 | 1.95 | V    | 1, 2 |

Note :

1. All Voltages are referenced to VSS = 0V
2. VDDQ must not exceed the level of VDD

## CLOCK INPUTS (TA= -25 to 85°C )

| Parameter                          | Symbol  | Min      | Max      | Unit | Note |
|------------------------------------|---------|----------|----------|------|------|
| DC Input Voltage                   | VIN     | -0.3     | VDDQ+0.3 | V    |      |
| DC Input Differential Voltage      | VID(DC) | 0.4*VDDQ | VDDQ+0.6 | V    | 1    |
| AC Input Differential Voltage      | VID(AC) | 0.6*VDDQ | VDDQ+0.6 | V    | 1    |
| AC Differential Crosspoint Voltage | VIX     | 0.4*VDDQ | 0.6*VDDQ | V    | 2    |

Note :

1. VID(DC) and VID(AC) are the magnitude of the difference between the input level on CK and the input level on  $\overline{CK}$ .
2. The value of VIX is expected to be 0.5\*VDDQ and must track variations in the DC level of the same.

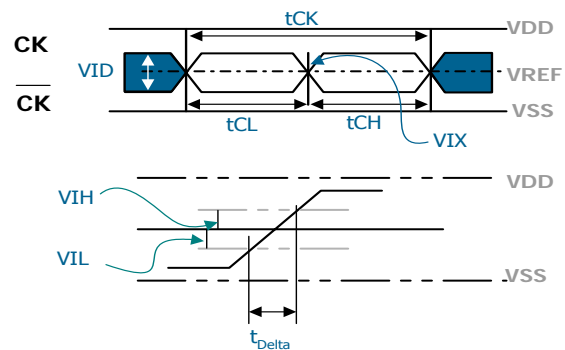

$$\text{Input signal slew rate} = [V_{IH(AC)} - V_{IL(AC)}] / t_{\Delta}$$

### Address And Command Inputs (A0~An, BA0, BA1, $\overline{\text{CKE}}$ , $\overline{\text{RAS}}$ , $\overline{\text{CAS}}$ , $\overline{\text{WE}}$ )

| Parameter          | Symbol          | Min                  | Max                   | Unit | Note |
|--------------------|-----------------|----------------------|-----------------------|------|------|
| Input High Voltage | V <sub>IH</sub> | 0.8*V <sub>DDQ</sub> | V <sub>DDQ</sub> +0.3 | V    |      |
| Input Low Voltage  | V <sub>IL</sub> | -0.3                 | 0.2*V <sub>DDQ</sub>  | V    |      |

### Data Inputs (DQ0 - DQ15, UDM, LDM, UDQS, LDQS)

| Parameter             | Symbol                | Min                  | Max                   | Unit | Note |
|-----------------------|-----------------------|----------------------|-----------------------|------|------|
| DC Input High Voltage | V <sub>IHD</sub> (DC) | 0.7*V <sub>DDQ</sub> | V <sub>DDQ</sub> +0.3 | V    |      |
| DC Input Low Voltage  | V <sub>ILD</sub> (DC) | -0.3                 | 0.3*V <sub>DDQ</sub>  | V    |      |
| AC Input High Voltage | V <sub>IHD</sub> (AC) | 0.8*V <sub>DDQ</sub> | V <sub>DDQ</sub> +0.3 | V    |      |
| AC Input Low Voltage  | V <sub>ILD</sub> (AC) | -0.3                 | 0.2*V <sub>DDQ</sub>  | V    |      |

### Data Outputs (DQ0 - DQ15, UDQS, LDQS)

| Parameter  | Symbol          | Min                  | Max                  | Unit | Note |
|--|-----------------|----------------------|----------------------|------|------|
| DC Output High Voltage<br>(I <sub>OH</sub> = -0.1mA) | V <sub>OH</sub> | 0.9*V <sub>DDQ</sub> | -                    | V    |      |
| DC Output High Voltage<br>(I <sub>OL</sub> = 0.1mA)  | V <sub>OL</sub> | -                    | 0.1*V <sub>DDQ</sub> | V    |      |

### DC CHARACTERISTICS I (T<sub>A</sub>= -25 to 85°C)

| Parameter              | Symbol          | Min  | Max | Unit | Note |
|------------------------|-----------------|------|-----|------|------|
| Input Leakage Current  | I <sub>LI</sub> | -1   | 1   | uA   | 1    |
| Output Leakage Current | I <sub>LO</sub> | -1.5 | 1.5 | uA   | 2    |

**Note :**

1. V<sub>IN</sub> = 0 to 1.8V. All other pins are not tested under V<sub>IN</sub>=0V.
2. DOUT is disabled. V<sub>OUT</sub>= 0 to 1.95V.

**AC OPERATING TEST CONDITION** ( $T_A = -25$  to  $85$  °C,  $V_{DD} = 1.8V$ ,  $V_{SS} = 0V$ )

| Parameter   | Symbol            | Value                     | Unit | Note |
|---|-------------------|---------------------------|------|------|
| AC Input High/Low Level Voltage                     | $V_{IH} / V_{IL}$ | $0.9 \cdot V_{DDQ} / 0.2$ | V    |      |
| Input Timing Measurement Reference Level Voltage    | $V_{trip}$        | $0.5 \cdot V_{DDQ}$       | V    |      |
| Input Rise/Fall Time                                | $t_R / t_F$       | 1                         | ns   |      |
| Output Timing Measurement Reference Level Voltage   | $V_{outref}$      | $0.5 \cdot V_{DDQ}$       | V    |      |
| Output Load Capacitance for Access Time Measurement | CL                |                           | pF   | 1    |

Note 1.

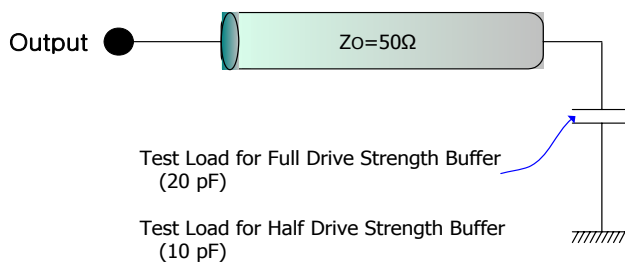

### Mobile DDR OUTPUT SLEW RATE CHARACTERISTICS

| Parameter  | Min | Max | Unit | Note |
|--|-----|-----|------|------|
| Pull-up and Pull-Down Slew Rate for Full Strength Driver | 0.7 | 2.5 | V/ns | 1, 2 |
| Pull-up and Pull-Down Slew Rate for Half Strength Driver | 0.3 | 1.0 | V/ns | 1, 2 |
| Output Slew Rate Matching ratio (Pull-up to Pull-down)   | 0.7 | 1.4 | -    | 3    |

Note :

1. Measured with a test load of 20pF connected to VSSQ
2. Output slew rate for rising edge is measured between VILD(DC) to VIH(DC) and for falling edge between VIH(DC) to VILD(AC)
3. The ratio of pull-up slew rate to pull-down slew rate is specified for the same temperature and voltage, over the entire temperature and voltage range. For a given output, it represents the maximum difference between pull-up and pull-down drivers due to process variation.

### Mobile DDR AC OVERSHOOT / UNDERSHOOT SPECIFICATION

| Parameter  | Specification |
|--|---------------|
| Maximum peak amplitude allowed for overshoot                             | 0.5V          |
| Maximum peak amplitude allowed for undershoot                            | 0.5V          |
| The area between overshoot signal and VDD must be less than or equal to  | 3V-ns         |
| The area between undershoot signal and GND must be less than or equal to | 3V-ns         |

Note :

1. This specification is intended for devices with no clamp protection and is guaranteed by design.

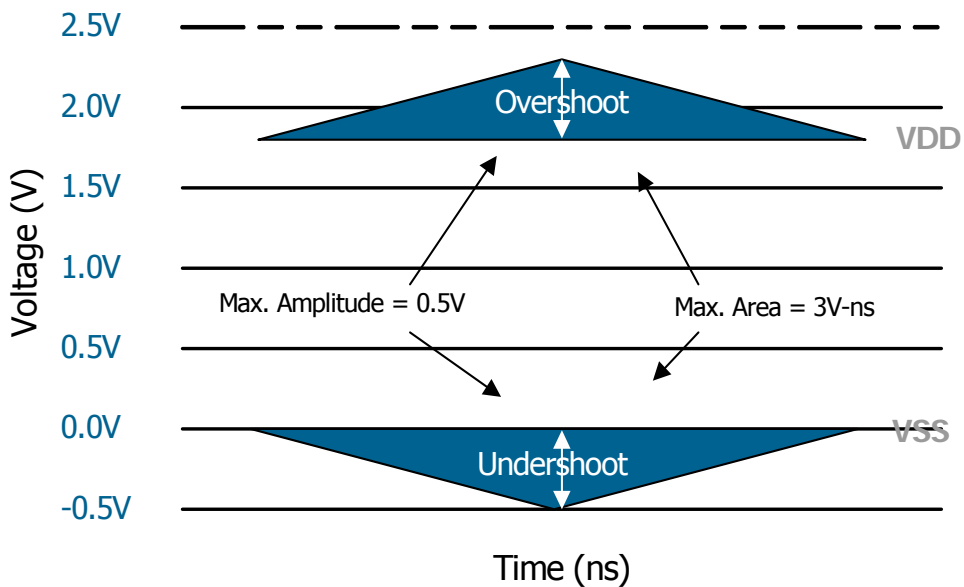

**DC CHARACTERISTICS II** (TA= -25 to 85°C) (Sheet 1 of 2)

| Parameter  | Symbol | Test Condition   | Max     |         |         | Unit | Note |
|--|--------|--|---------|---------|---------|------|------|
|  |        |  | DDR 333 | DDR 266 | DDR 200 |      |      |
| Operating one bank active-precharge current              | IDD0   | tRC = tRC(min)<br>tCK = tCK(min)<br>CKE is HIGH<br>CS is HIGH between valid commands<br>address inputs are SWITCHING<br>data bus inputs are STABLE | 70      | 65      | 60      | mA   | 1    |
| Precharge power-down standby current                     | IDD2P  | all banks idle,<br>CKE is LOW<br>CS is HIGH, tCK = tCK(min)<br>address and control inputs are SWITCHING<br>data bus inputs are STABLE              | 0.3     |         |         | mA   |      |
| Precharge power-down standby current with clock stop     | IDD2PS | all banks idle,<br>CKE is LOW<br>CS is HIGH, CK = LOW, CK = HIGH<br>address and control inputs are SWITCHING<br>data bus inputs are STABLE         | 0.3     |         |         | mA   |      |
| Precharge non power-down standby current                 | IDD2N  | all banks idle,<br>CKE is HIGH<br>CS is HIGH, tCK = tCK(min)<br>address and control inputs are SWITCHING<br>data bus inputs are STABLE             | 10      |         |         | mA   |      |
| Precharge non power-down standby current with clock stop | IDD2NS | all banks idle,<br>CKE is HIGH<br>CS is HIGH, CK = LOW, CK = HIGH<br>address and control inputs are SWITCHING<br>data bus inputs are STABLE        | 5.0     |         |         | mA   |      |
| Active power-down standby current                        | IDD3P  | one bank active,<br>CKE is LOW<br>CS is HIGH, tCK = tCK(min)<br>address and control inputs are SWITCHING<br>data bus inputs are STABLE             | 5.0     |         |         | mA   |      |
| Active power-down standby current with clock stop        | IDD3PS | one bank active,<br>CKE is LOW<br>CS is HIGH, CK = LOW, CK = HIGH<br>address and control inputs are SWITCHING<br>data bus inputs are STABLE        | 3.0     |         |         | mA   |      |

**DC CHARACTERISTICS II** (TA= -25 to 85°C) (Sheet 2 of 2)

| Parameter   | Symbol | Test Condition  | Max           |         |         | Unit | Note |
|---|--------|---|---------------|---------|---------|------|------|
|   |        |   | DDR 333       | DDR 266 | DDR 200 |      |      |
| Active non power-down standby current                 | IDD3N  | one bank active<br>CKE is HIGH<br>$\overline{CS}$ is HIGH, $t_{CK} = t_{CK(min)}$<br>address and control inputs are SWITCHING<br>data bus inputs are STABLE                     | 15            |         |         | mA   |      |
| Active non power-down standby current with clock stop | IDD3NS | one bank active<br>CKE is HIGH<br>$\overline{CS}$ is HIGH, $CK = LOW$ , $\overline{CK} = HIGH$<br>address and control inputs are SWITCHING<br>data bus inputs are STABLE        | 10            |         |         |      |      |
| Operating burst read current                          | IDD4R  | one bank active<br>BL=4<br>CL=3<br>$t_{CK} = t_{CK(min)}$<br>continuous read bursts<br>IOU=0mA<br>address inputs are SWITCHING<br>50% data change each burst transfer           | 120           | 100     | 90      | mA   | 1    |
| Operating burst write current                         | IDD4W  | one bank active<br>BL=4<br>$t_{CK} = t_{CK(min)}$<br>continuous write bursts<br>address inputs are SWITCHING<br>50% data change each burst transfer                             | 120           | 100     | 90      |      |      |
| Auto Refresh Current                                  | IDD5   | $t_{RC} = t_{RFC(min)}$<br>$t_{CK} = t_{CK(min)}$<br>burst refresh<br>CKE is HIGH<br>address and control inputs are SWITCHING<br>data bus inputs are STABLE                     | 150           | 150     | 130     | mA   |      |
| Self Refresh Current                                  | IDD6   | CKE is LOW<br>$CK = LOW$ , $CK = HIGH$ , $t_{CK} = t_{CK(min)}$<br>Extended Mode Register set to all 0's<br>address and control inputs are STABLE<br>data bus inputs are STABLE | See Next Page |         |         | mA   | 2    |
| Standby Current in Deep Power Down Mode               | IDD8   | See p.53 ~ 54   |               |         |         |      |      |

**Note : IDD values are for full operating range of voltage and temperature.**

1. IDD specifications are tested after the device is properly initialized
2. Input slew rate is 1V/ns
3. Definitions for IDD:
  - LOW is defined as  $V_{IN} \leq 0.1 * V_{DDQ}$
  - HIGH is defined as  $V_{IN} \geq 0.9 * V_{DDQ}$
  - STABLE is defined as inputs stable at a HIGH or LOW level
  - SWITCHING is defined as
    - address and command: inputs changing between HIGH and LOW once per two clock cycles
    - data bus inputs: DQ changing between HIGH and LOW once per clock cycle
 DM and DQS are STABLE

### DC CHARACTERISTICS III - IDD6

| Temp.<br>(°C) | Memory Array |         |        | Unit |
|---------------|--------------|---------|--------|------|
|               | 4 Banks      | 2 Banks | 1 Bank |      |
| 45            | 280          | 235     | 185    | µA   |
| 85            | 550          | 370     | 270    | µA   |

**Notes:**

1. VDD / VDDQ = 1.8V
2. Related numerical values in this 45°C are examples for reference sample value only.
3. With a on-chip temperature sensor of Mobile memory, auto temperature compensated self refresh will automatically adjust the interval of self-refresh operation according to ambient temperature variations.

**AC CHARACTERISTICS** (AC operating conditions unless otherwise noted) (Sheet 1 of 2)

| Parameter   | Symbol                             | DDR333               |      | DDR266               |      | DDR200               |      | Unit | Note  |
|---|------------------------------------|----------------------|------|----------------------|------|----------------------|------|------|-------|
|   |                                    | Min                  | Max  | Min                  | Max  | Min                  | Max  |      |       |
| DQ Output Access Time (from CK, $\overline{CK}$ )     | tAC                                | 2.0                  | 5.5  | 2.0                  | 6.5  | 2.0                  | 7.0  | ns   |       |
| DQS Output Access Time (from CK, $\overline{CK}$ )    | tDQSCK                             | 2.0                  | 5.5  | 2.0                  | 6.5  | 2.0                  | 7.0  | ns   |       |
| Clock High-level Width                                | tCH                                | 0.45                 | 0.55 | 0.45                 | 0.55 | 0.45                 | 0.55 | tCK  |       |
| Clock Low-level Width                                 | tCL                                | 0.45                 | 0.55 | 0.45                 | 0.55 | 0.45                 | 0.55 | tCK  |       |
| Clock Half Period                                     | tDQSCK                             | tCL,<br>tCH<br>(Min) | -    | tCL,<br>tCH<br>(Min) | -    | tCL,<br>tCH<br>(Min) | -    | ns   | 1,2   |
| System Clock Cycle Time                               | $\overline{CAS}$ Latency=3<br>tCK3 | 6.0                  | -    | 7.5                  | -    | 10                   | -    | ns   | 3     |
| DQ and DM Input Setup Time                            | tDS                                | 0.7                  |      | 0.9                  |      | 1.2                  |      | ns   | 4,5,6 |
| DQ and DM Input Hold Time                             | tDH                                | 0.7                  |      | 0.9                  |      | 1.2                  |      | ns   | 4,5,6 |
| DQ and DM Input Pulse Width                           | tDIPW                              | 1.4                  | -    | 1.8                  | -    | 2.4                  | -    | ns   | 7     |
| Address and Control Input Setup Time                  | tIS                                | 1.3                  |      | 1.5                  |      | 1.7                  |      | ns   | 6,8,9 |
| Address and Control Input Hold Time                   | tIH                                | 1.3                  |      | 1.5                  |      | 1.7                  |      | ns   | 6,8,9 |
| Address and Control Input Pulse Width                 | tIPW                               | 2.7                  | -    | 3.0                  | -    | 3.4                  | -    | ns   | 7     |
| DQ & DQS Low-impedance time from CK, $\overline{CK}$  | tLZ                                | 1.0                  | -    | 1.0                  | -    | 1.0                  | -    | ns   | 10    |
| DQ & DQS High-impedance time from CK, $\overline{CK}$ | tHZ                                |                      | 5.5  |                      | 6.5  |                      | 7.0  | ns   | 10    |
| DQS - DQ Skew   | tDQSQ                              |                      | 0.5  |                      | 0.6  |                      | 0.7  | ns   | 11    |
| DQ / DQS output hold time from DQS                    | tQH                                | tHP -<br>tQHS        |      | tHP -<br>tQHS        |      | tHP -<br>tQHS        |      | ns   | 2     |
| Data Hold Skew Factor                                 | tQHS                               |                      | 0.65 |                      | 0.75 |                      | 1.0  | ns   | 2     |
| Write Command to 1st DQS Latching Transition          | tDQSS                              | 0.75                 | 1.25 | 0.75                 | 1.25 | 0.75                 | 1.25 | tCK  |       |
| DQS Input High-Level Width                            | tDQSH                              | 0.4                  | 0.6  | 0.4                  | 0.6  | 0.4                  | 0.6  | tCK  |       |
| DQS Input Low-Level Width                             | tDQSL                              | 0.4                  | 0.6  | 0.4                  | 0.6  | 0.4                  | 0.6  | tCK  |       |

**AC CHARACTERISTICS** (AC operating conditions unless otherwise noted) (Sheet 2 of 2)

| Parameter  | Symbol                                     | DDR333                |        | DDR266     |        | DDR200     |        | Unit | Note |
|--|--|-----------------------|--------|------------|--------|------------|--------|------|------|
|  |  | Min                   | Max    | Min        | Max    | Min        | Max    |      |      |
| DQS Falling Edge to CK Setup Time                      | tDSS                                       | 0.2                   | -      | 0.2        | -      | 0.2        | -      | tCK  |      |
| DQS Falling Edge Hold Time From CK                     | tDSH                                       | 0.2                   | -      | 0.2        | -      | 0.2        | -      | tCK  |      |
| MODE REGISTER SET Command Period                       | tMRD                                       | 2                     | -      | 2          | -      | 2          | -      | tCK  |      |
| Write Preamble Setup Time                              | tWPRES                                     | 0                     | -      | 0          | -      | 0          | -      | ns   | 12   |
| Write Postamble  | tWPST                                      | 0.4                   | 0.6    | 0.4        | 0.6    | 0.4        | 0.6    | tCK  | 13   |
| Write Preamble   | tWPRE                                      | 0.25                  | -      | 0.25       | -      | 0.25       | -      | tCK  |      |
| Read Preamble  | $\overline{\text{CAS}}$ Latency=3<br>tRPRE | 0.9                   | 1.1    | 0.9        | 1.1    | 0.9        | 1.1    | tCK  | 14   |
| Read Postamble   | tRPST                                      | 0.4                   | 0.6    | 0.4        | 0.6    | 0.4        | 0.6    | tCK  |      |
| ACTIVE to PRECHARGE Command Period                     | tRAS                                       | 42                    | 70,000 | 45         | 70,000 | 50         | 70,000 | ns   |      |
| ACTIVE to ACTIVE Command Period                        | tRC  | 60                    | -      | 75         | -      | 80         | -      | ns   |      |
| AUTO REFRESH to ACTIVE/AUTO REFRESH Command Period     | tREFC                                      | 80                    | -      | 80         | -      | 80         | -      | ns   |      |
| ACTIVE to READ or WRITE Delay                          | tRCD                                       | 18                    | -      | 22.5       | -      | 30         | -      | ns   | 15   |
|  |  | 30                    | -      | 30         | -      | 30         | -      | ns   | 16   |
| PRECHARGE Command Period                               | tRP  | 18                    | -      | 22.5       | -      | 30         | -      | ns   | 15   |
|  |  | 30                    | -      | 30         | -      | 30         | -      | ns   | 16   |
| ACTIVE Bank A to ACTIVE Bank B Delay                   | tRRD                                       | 12                    | -      | 15         | -      | 15         | -      | ns   |      |
| WRITE Recovery Time                                    | tWR  | 15                    | -      | 15         | -      | 15         | -      | ns   |      |
| Auto Precharge Write Recovery + Precharge Time         | tDAL                                       | (tWR/tCK) + (tRP/tCK) |        |            |        |            |        |      | 17   |
| Internal Write to Read Command Delay                   | tWTR                                       | 2                     | -      | 1          | -      | 1          | -      | tCK  |      |
| Self Refresh Exit to next valid Command Delay          | tXSR                                       | 200                   | -      | 200        | -      | 200        | -      | ns   |      |
| Exit Power Down to next valid Command Delay            | tXP  | tIS + 1CLK            | -      | tIS + 1CLK | -      | tIS + 1CLK | -      | ns   |      |
| CKE <i>min.</i> Pulse Width (High and Low Pulse Width) | tCKE                                       | 2                     | -      | 2          | -      | 2          | -      | tCK  |      |
| Average Periodic Refresh Interval                      | tREFI                                      | 7.8                   | -      | 7.8        | -      | 7.8        | -      | us   | 18   |
| Refresh Period   | tREF                                       | -                     | 64     | -          | 64     | -          | 64     | ms   |      |

Note :

1. Min (tCL, tCH) refers to the smaller of the actual clock low time and the actual clock high time as provided to the device (i.e. this value can be greater than the minimum specification limits for tCL and tCH)
2. tQH = tHP - tQHS, where tHP = minimum half clock period for any given cycle and is defined by clock high or clock low (tCL, tCH). tQHS accounts for
  - 1) the pulse duration distortion of on-chip clock circuits; and 2) the worst case push-out of DQS on one transition followed by the worst case pull-in of DQ on the next transition, both of which are, separately, due to data pin skew and output pattern effects, and p-channel to n-channel variation of the output drivers.
3. The only time that the clock frequency is allowed to change is during clock stop, power-down or self-refresh modes.
4. The transition time for DQ, DM and DQS inputs is measured between VIL(DC) to VIH(AC) for rising input signals, and VIH(DC) to VIL(AC) for falling input signals.
5. DQS, DM and DQ input slew rate is specified to prevent double clocking of data and preserve setup and hold times. Signal transitions through the DC region must be monotonic.
6. Input slew rate  $\geq 0.5$  V/ns and  $< 1.0$  V/ns.
7. These parameters guarantee device timing but they are not necessarily tested on each device.
8. The transition time for address and command inputs is measured between VIH and VIL.
9. A  $CK/\overline{CK}$  differential slew rate of 2.0 V/ns is assumed for this parameter.
10. tHZ and tLZ transitions occur in the same access time windows as valid data transitions. These parameters are not referred to a specific voltage level, but specify when the device is no longer driving (HZ), or begins driving (LZ).
11. tDQSQ consists of data pin skew and output pattern effects, and p-channel to n-channel variation of the output drivers for any given cycle.
12. The specific requirement is that DQS be valid (HIGH, LOW, or some point on a valid transition) on or before this CK edge. A valid transition is defined as monotonic and meeting the input slew rate specifications of the device. When no writes were previously in progress on the bus, DQS will be transitioning from Hi-Z to logic LOW. If a previous write was in progress, DQS could be HIGH, LOW, or transitioning from HIGH to LOW at this time, depending on tDQSS.
13. The maximum limit for this parameter is not a device limit. The device operates with a greater value for this parameter, but system performance (bus turnaround) will degrade accordingly.
14. A low level on DQS may be maintained during High-Z states (DQS drivers disabled) by adding a weak pull-down element in the system. It is recommended to turn off the weak pull-down element during read and write bursts (DQS drivers enabled).
15. Speed bin (CL-trCD-trP) = 3-3-3 (DDR266 & DDR333 only)
16. Speed bin (CL-trCD-trP) = 3-4-4 (DDR266 only) , 3-5-5 (DDR333 only)
17. tDAL = (tWR/tCK) + (tRP/tCK) : for each of the terms above, if not already an integer, round to the next higher integer.
18. A maximum of eight Refresh commands can be posted to any given Low-Power DDR SDRAM, meaning that the maximum absolute interval between any Refresh command and the next Refresh command is  $8 \cdot tREFI$ .

### Mobile DDR SDRAM OPERATION State Diagram

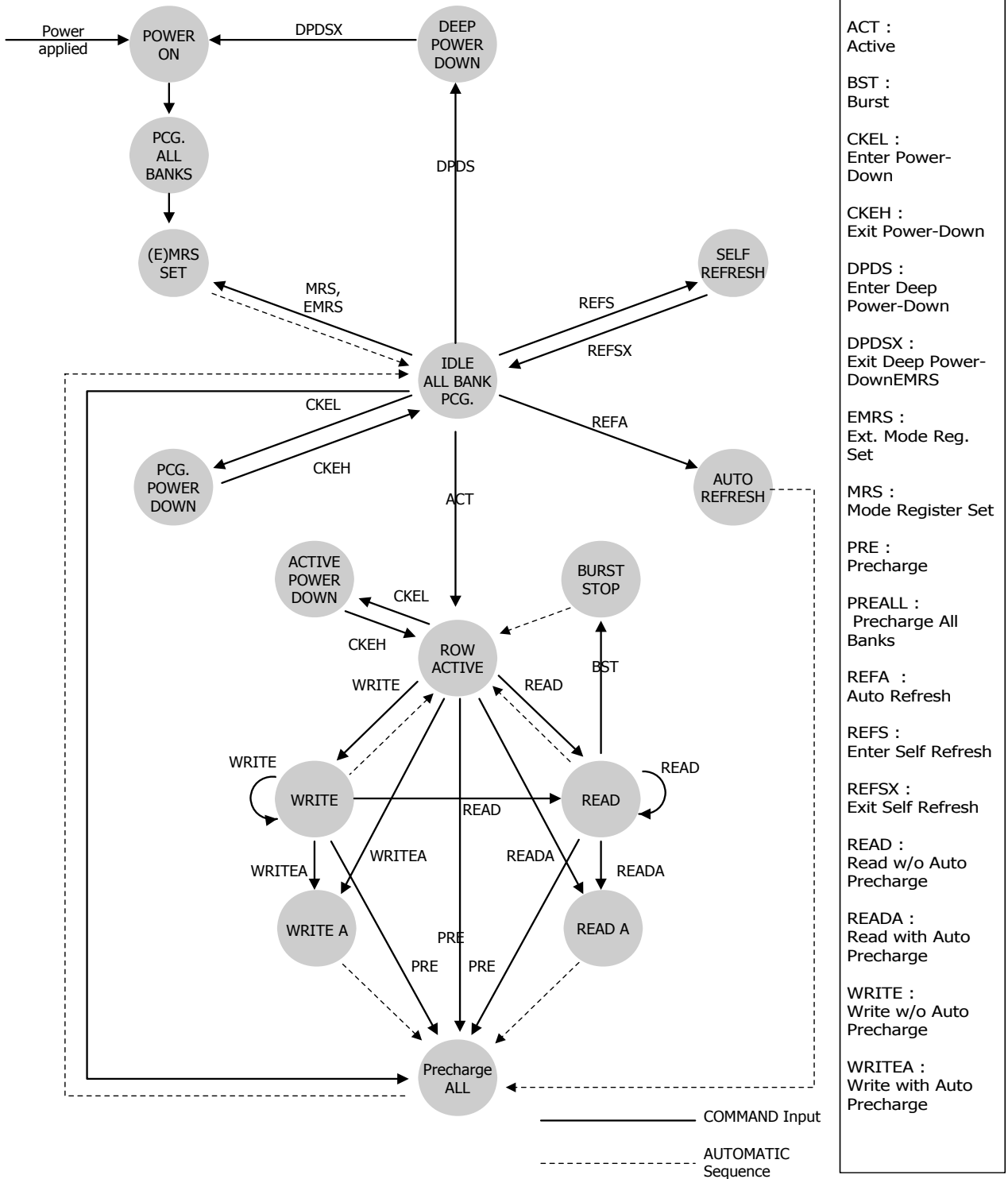

- ACT : Active
- BST : Burst
- CKEL : Enter Power-Down
- CKEH : Exit Power-Down
- DPDS : Enter Deep Power-Down
- DPDSX : Exit Deep Power-DownEMRS
- EMRS : Ext. Mode Reg. Set
- MRS : Mode Register Set
- PRE : Precharge
- PREALL : Precharge All Banks
- REFA : Auto Refresh
- REFS : Enter Self Refresh
- REFSX : Exit Self Refresh
- READ : Read w/o Auto Precharge
- READA : Read with Auto Precharge
- WRITE : Write w/o Auto Precharge
- WRITEA : Write with Auto Precharge

### DESELECT

The Deselect function ( $\overline{CS} = \text{High}$ ) prevents new commands from being executed by the Mobile DDR SDRAM. The LPDDR SDRAM is effectively deselected. Operations already in progress are not affected.

### NO OPERATION

The NO OPERATION (NOP) command is used to perform a NOP to a Mobile DDR SDRAM that is selected ( $\overline{CS} = \text{Low}$ ,  $\overline{RAS} = \overline{CAS} = \overline{WE} = \text{High}$ ). This prevents unwanted commands from being registered during idle or wait states. Operations already in progress are not affected. (see to next figure)

### ACTIVE

The Active command is used to activate a row in particular bank for a subsequent Read or Write access. The value of the BA0,BA1 inputs selects the bank, and the address provided on A0-A12(or the highest address bit) selects the row. (see to next figure)

Before any READ or WRITE commands can be issued to a bank within the Mobile DDR SDRAM, a row in that bank must be opened. This is accomplished via the ACTIVE command, which selects both the bank and the row to be activated.

The row remains active until a PRECHARGE (or READ with AUTO PRECHARGE or WRITE with AUTO PRECHARGE) command is issued to the bank.

A PRECHARGE (or READ with AUTO PRECHARGE or WRITE with AUTO PRECHARGE) command must be issued before opening a different row in the same bank.

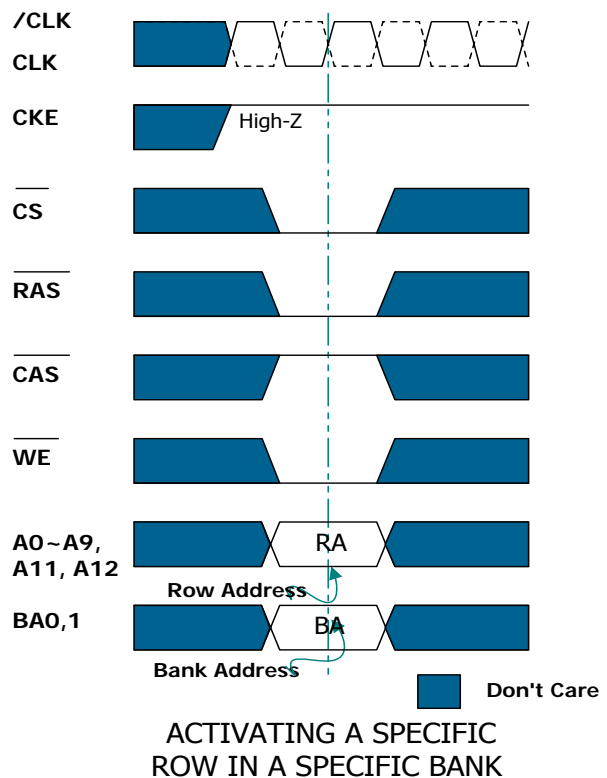
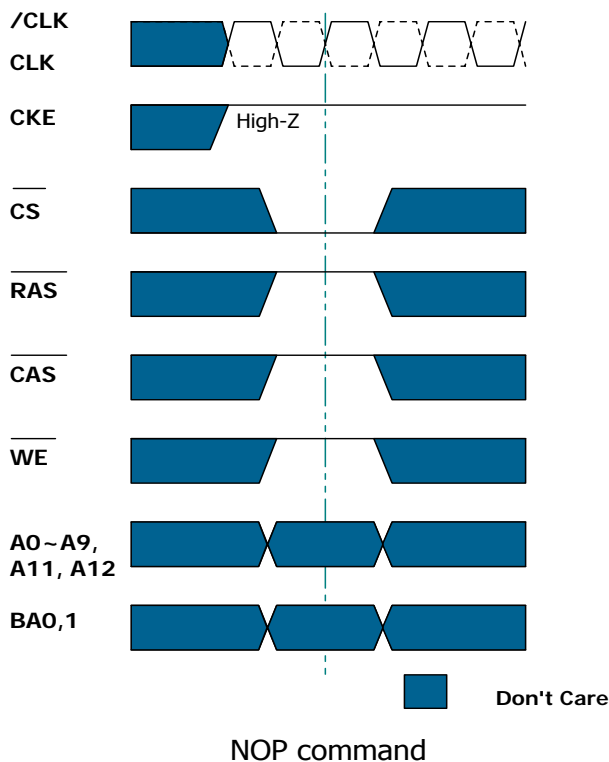

Once a row is Open(with an ACTIVE command) a READ or WRITE command may be issued to that row, subject to the tRCD specification. tRCD (MIN) should be divided by the clock period and rounded up to the next whole number to determine the earliest clock edge after the ACTIVE command on which a READ or WRITE command can be entered.

A subsequent ACTIVE command to a different row in the same bank can only be issued after the previous active row has been closed(precharge). The minimum time interval between successive ACTIVE commands to the same bank is defined by tRC.

A subsequent ACTIVE command to another bank can be issued while the first bank is being accessed, which results in a reduction of total row-access overhead. The minimum time interval between successive ACTIVE commands to different banks is defined by tRRD.

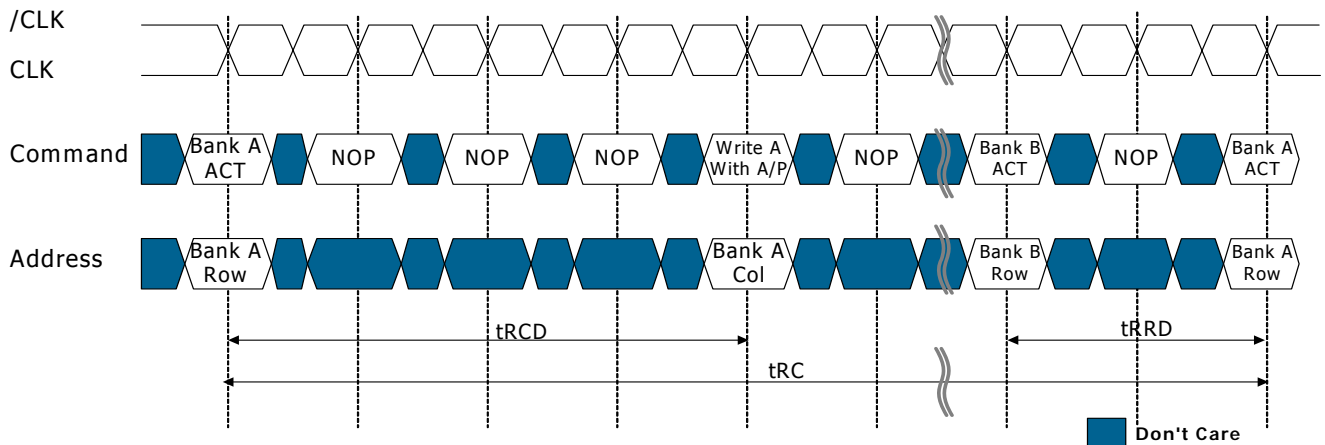

Once a row is Open(with an ACTIVE command) a READ or WRITE command may be issued to that row, subject to the tRCD specification. tRCD (MIN) should be divided by the clock period and rounded up to the next whole number to determine the earliest clock edge after the ACTIVE command on which a READ or WRITE command can be entered.

### READ / WRITE COMMAND

The READ command is used to initiate a Burst Read to an active row. The value of BA0 and BA1 selects the bank and address inputs select the starting column location.

The value of A10 determines whether or not auto precharge is used. If autoprecharge is selected, the row being accessed will be precharged at the end of the read burst; if auto precharge is not selected, the row will remain open for subsequent access. The valid data-out elements will be available CAS latency after the READ command is issued. The Mobile DDR drives the DQS during read operations. The initial low state of the DQS is known as the read preamble and the last data-out element is coincident with the read postamble. DQS is edge-aligned with read data. Upon completion of a burst, assuming no new READ commands have been initiated, the I/O's will go high-Z.

The WRITE command is used to initiate a Burst Write access to an active row. The value of BA0, BA1 selects the bank and address inputs select the starting column location.

The value of A10 determines whether or not auto precharge is used. If autoprecharge is selected, the row being accessed will be precharged at the end of the write burst; if auto precharge is not selected, the row will remain open for subsequent access. Input data appearing on the data bus, is written to the memory array subject to the DM input logic level appearing coincident with the data. If a given DM signal is registered low, the corresponding data will be written to the memory; if the DM signal is registered high, the corresponding data-inputs will be ignored, and a write will not be executed to that byte/column location. The memory controller drives the DQS during write operations. The initial low state of the DQS is known as the write preamble and the low state following the last data-in element is write postamble. Upon completion of a burst, assuming no new commands have been initiated, the I/O's will stay high-Z and any additional input data will be ignored.

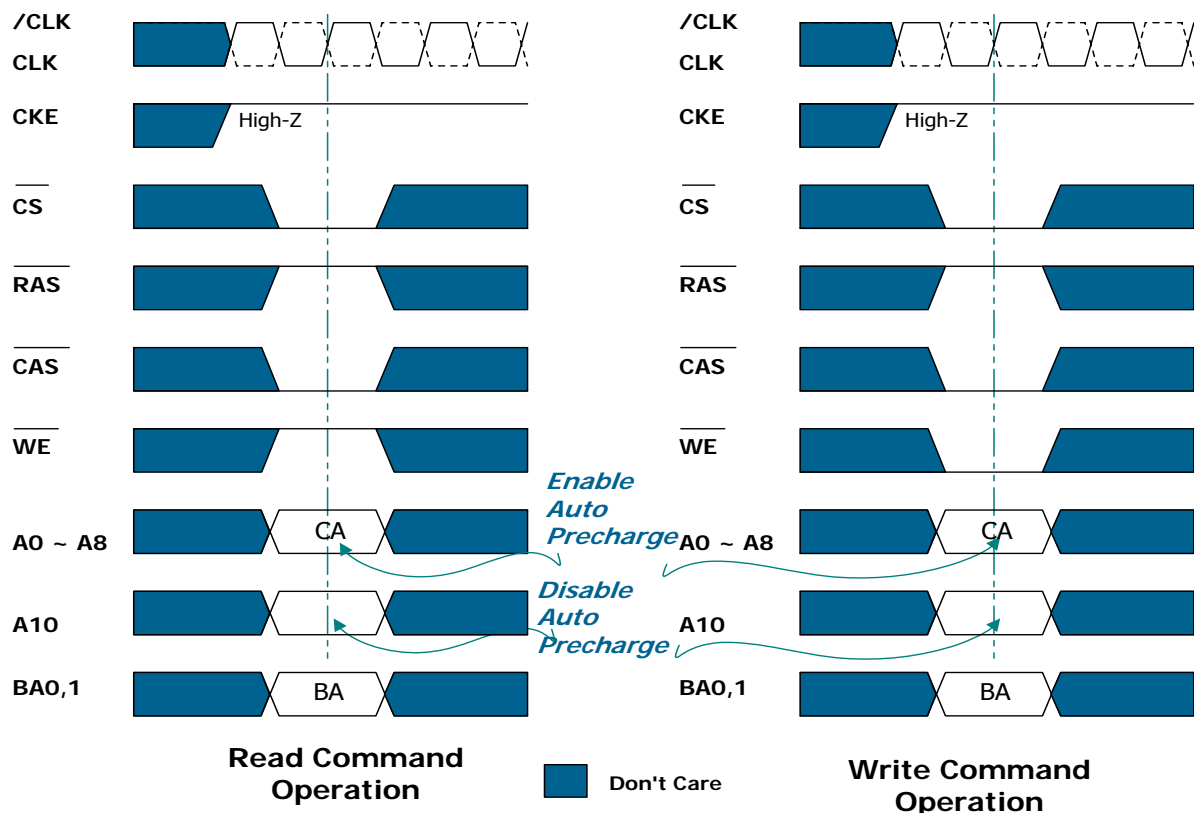

READ / WRITE COMMAND

**READ**

The basic Read timing parameters for DQs are shown next Figure(Basic Read Timing Parameter). ; they apply to all Read operations. During Read bursts, DQS is driven by the Mobile DDR SDRAM along with the output data. The initial Low state of the DQS is known as the read preamble; the Low state coincident with last data-out element is known as the read postamble.

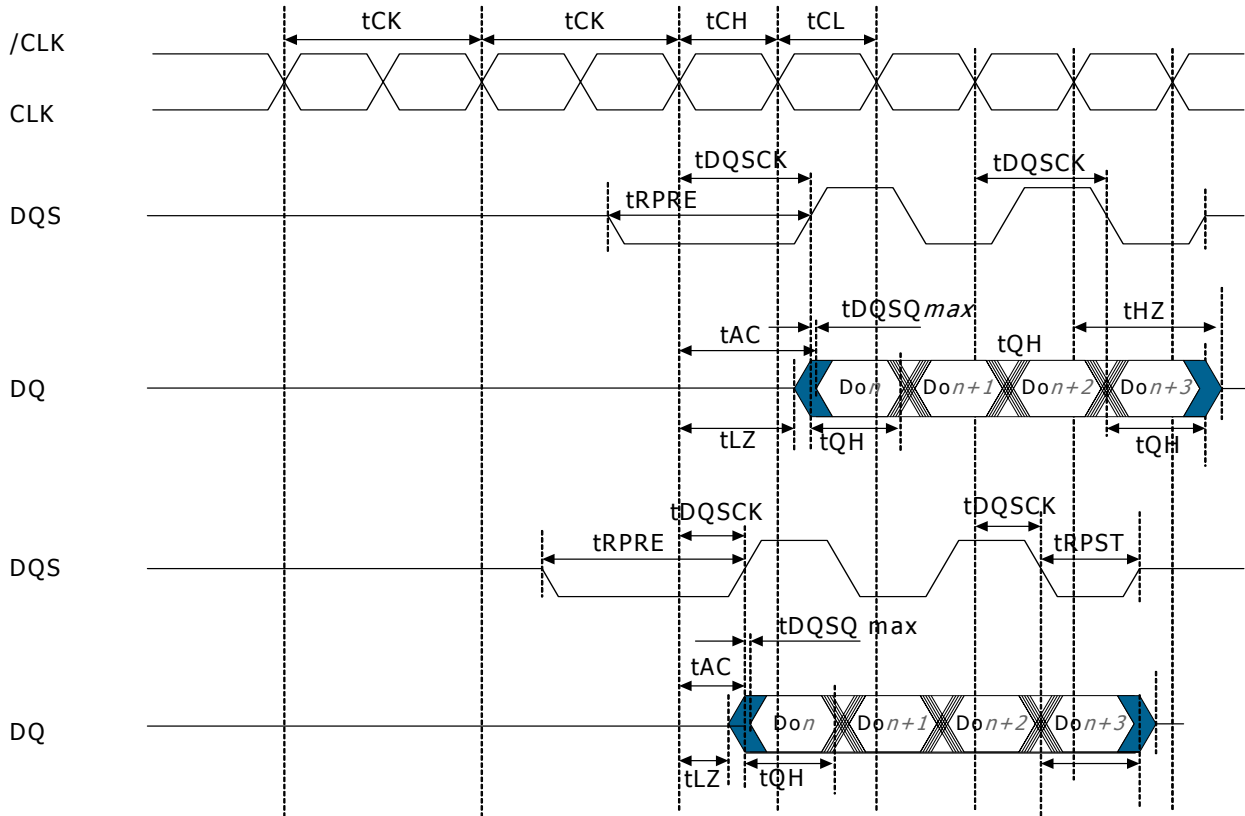

- 1) Do *n* : Data Out from column n
- 2) All DQ are valid tAC after the CK edge  
 All are valid tDQSQ after the DQS edge, regardless of tAC

Don't Care

**Basic Read Timing Parameter**

The first data-out element is edge aligned with the first rising edge of DQS and the successive data-out elements are edge aligned to successive edges of DQS. This is shown in next fig. with a CAS latency of 2 and 3. Upon completion of a read burst, assuming no other READ command has been initiated, the DQs will go to High-Z.

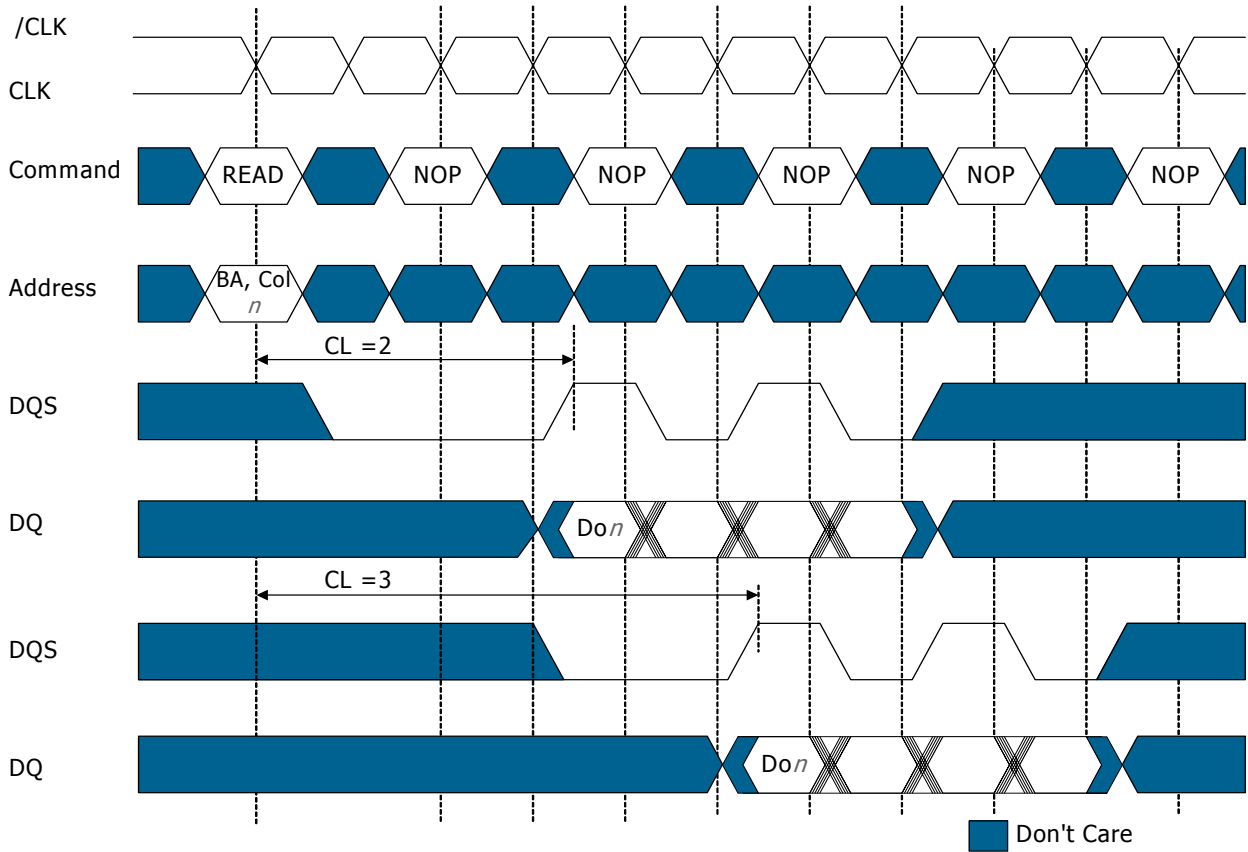

- 1) Do<sub>n</sub> : Data out from column n
- 2) BA, Col n = Bank A, Column n
- 3) Burst Length = 4 : 3 subsequent elements of Data Out appear in the programmed order following Do<sub>n</sub>
- 4) Shown with nominal t<sub>AC</sub>, t<sub>DQSCK</sub> and t<sub>DQSQ</sub>

Read Burst Showing CAS Latency

### READ to READ

Data from a read burst may be concatenated or truncated by a subsequent READ command. The first data from the new burst follows either the last element of a completed burst or the last desired element of a longer burst that is being truncated. The new READ command should be issued X cycles after the first READ command, where X equals

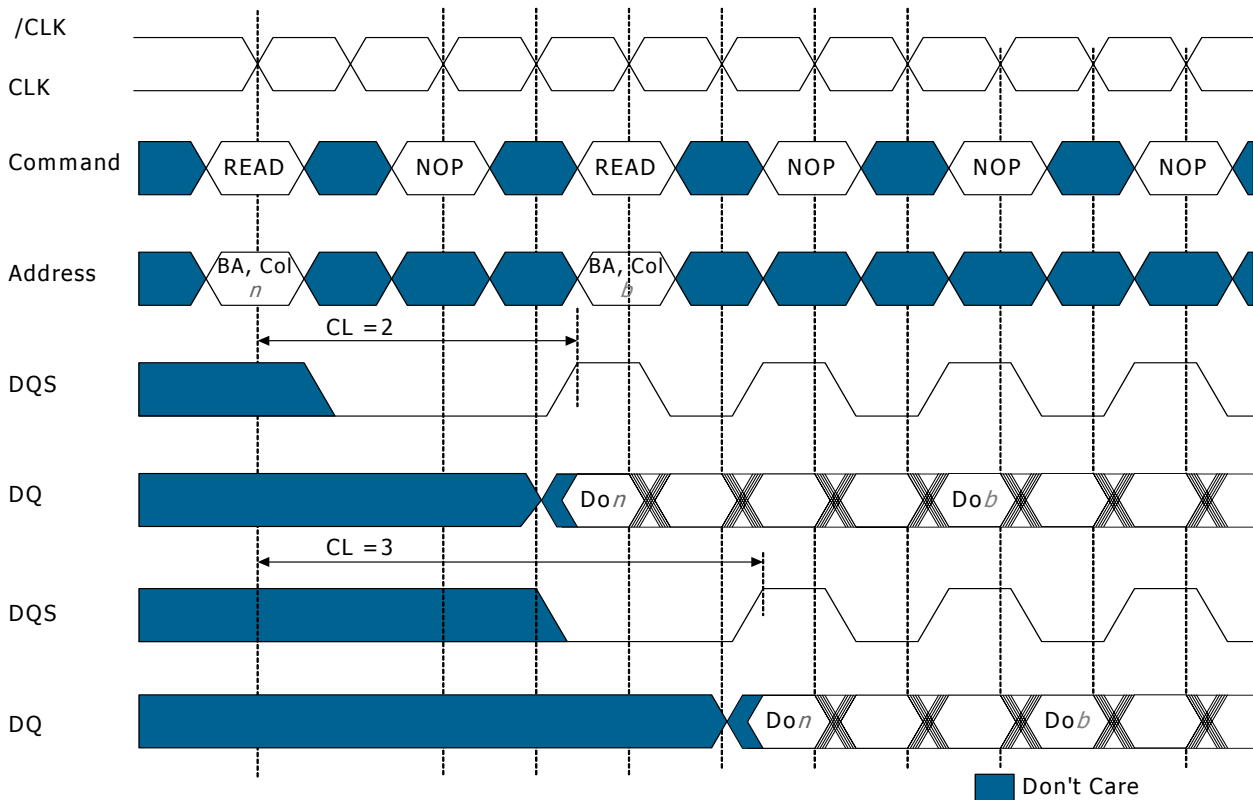

- 1)  $Do_n$  (or  $b$ ): Data out from column  $n$
- 2)  $BA, Col_n(b)$  = Bank A, Column  $n$  ( $b$ )
- 3) Burst Length = 4 : 3 subsequent elements of Data Out appear in the programmed order following  $Do_n(b)$
- 4) Shown with nominal  $t_{AC}$ ,  $t_{DQSCK}$  and  $t_{DQSQ}$

the number of desired data-out element pairs (pairs are required by the  $2n$  prefetch architecture).

### Consecutive Read Bursts

A READ command can be initiated on any clock cycle following a previous READ command. Non-consecutive Reads are shown in Figure. Full-speed random read accesses within a page or pages can be performed as shown in Fig.

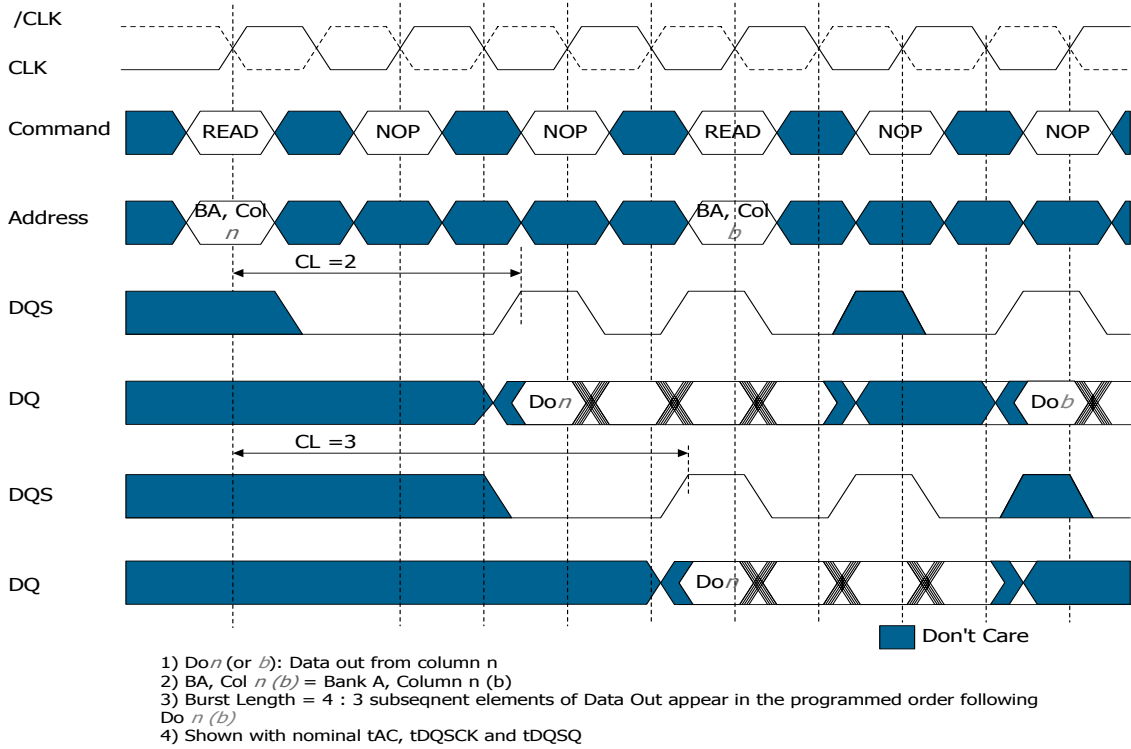

### Non-Consecutive Read Bursts

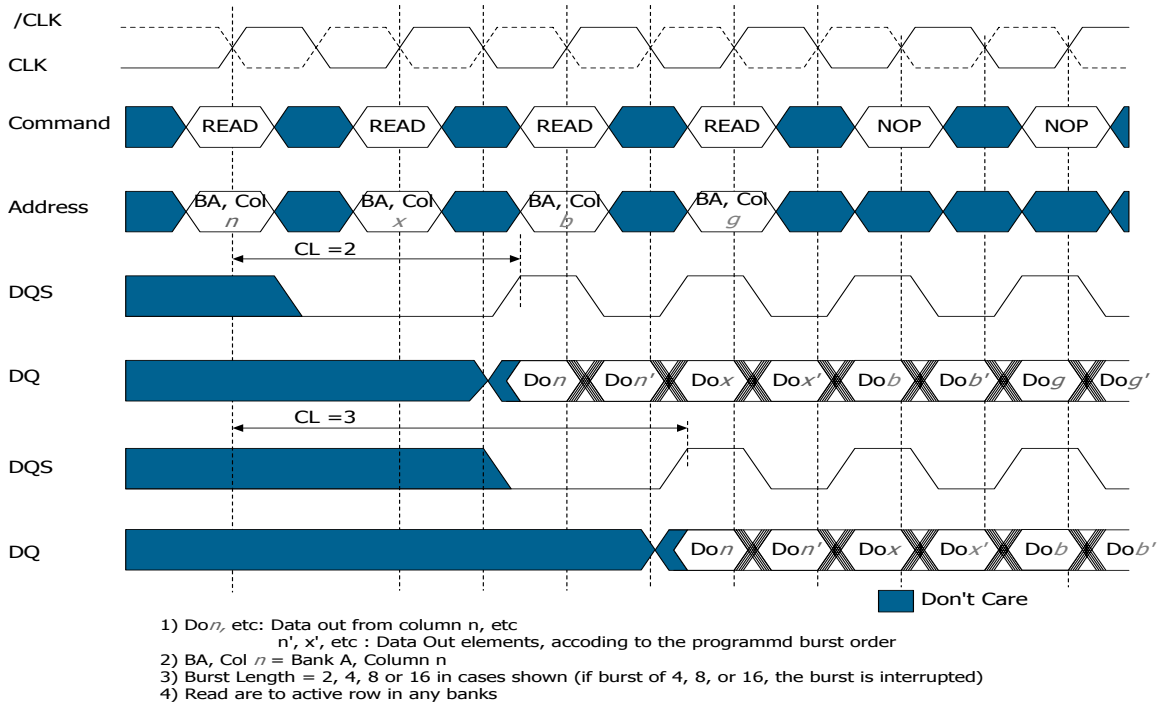

### Random Read Bursts

### READ BURST TERMINATE

Data from any READ burst may be truncated with a BURST TERMINATE command. The BURST TERMINATE latency is equal to the read (CAS) latency, i.e., the BURST TERMINATE command should be issued X cycles after the READ command where X equals the desired data-out element pairs.

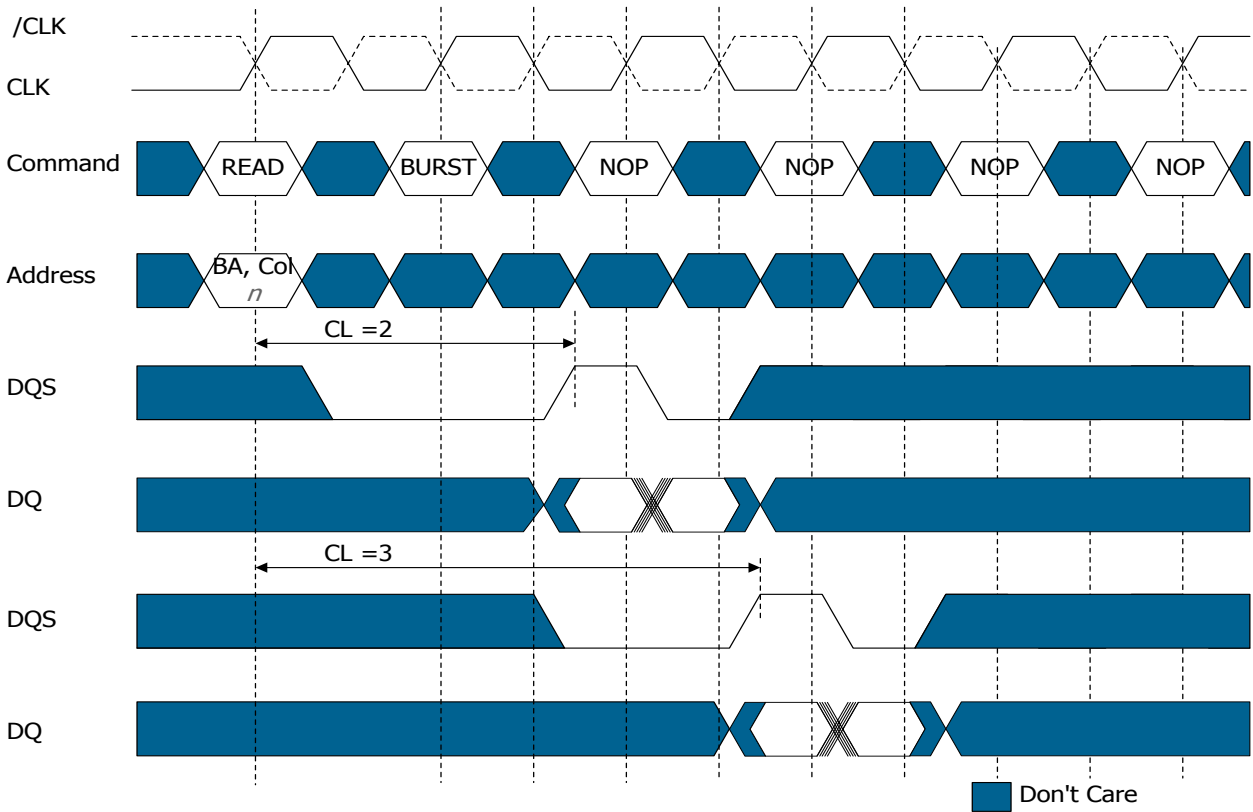

- 1) Do<sub>n</sub> : Data out from column n
- 2) BA, Col *n* = Bank A, Column n
- 3) Cases shown are bursts of 4, 8, or 16 terminated after 2 data elements
- 4) Shown with nominal tAC, tDQSK and tDQSQ

Terminating a Read Burst

### READ to WRITE

Data from READ burst must be completed or truncated before a subsequent WRITE command can be issued. If truncation is necessary, the BURST TERMINATE command must be used, as shown in next fig. for the case of nominal tDQSS.

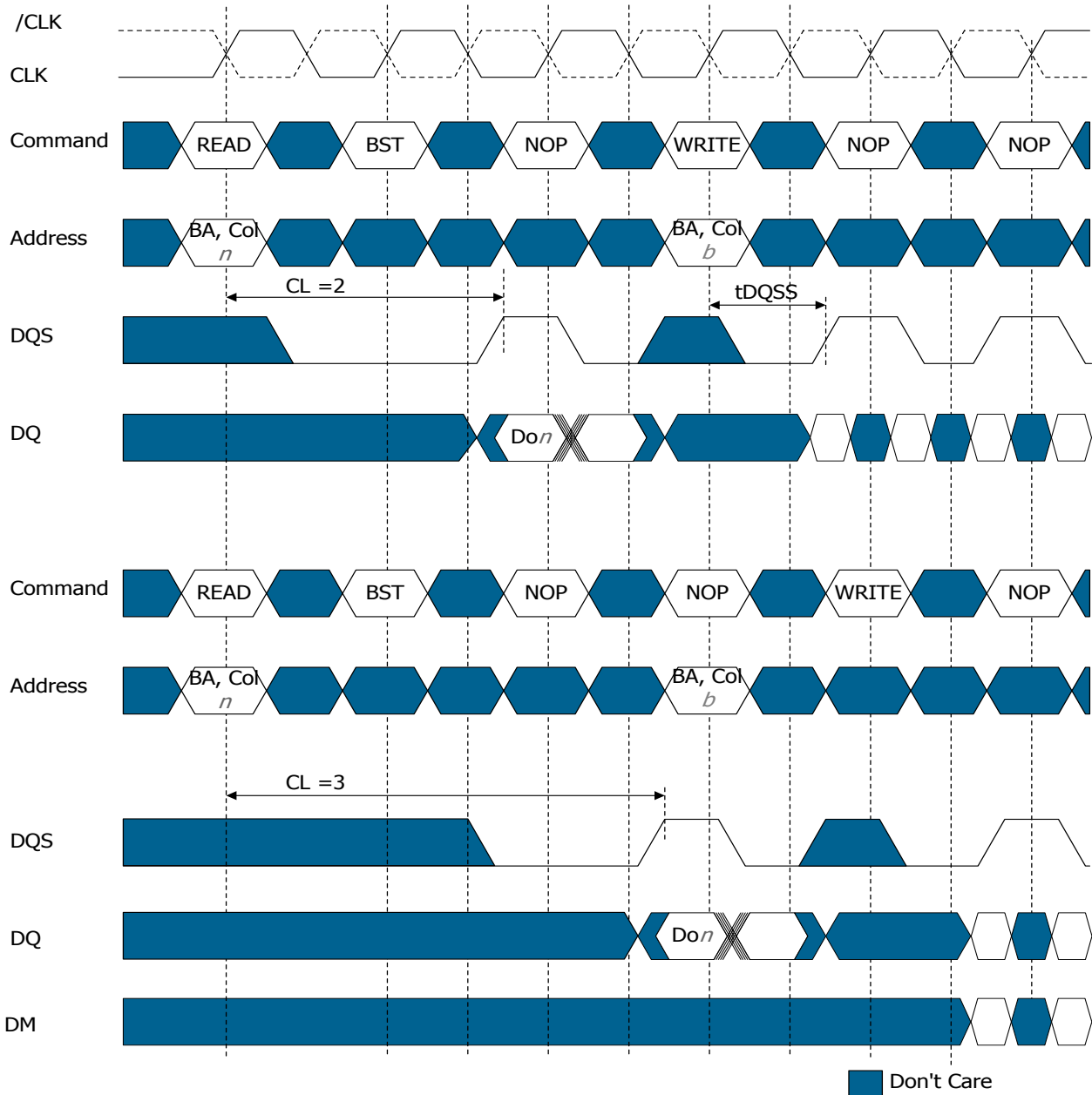

- 1) DO  $n$  = Data Out from column  $n$ ; DI  $b$  = Data In to column  $b$
- 2) Burst length = 4, 8 or 16 in the cases shown; if the burst length is 2, the BST command can be omitted
- 3) Shown with nominal tAC, tDQSCK and tDQSQ

### Read to Write

### READ to PRECHARGE

A Read burst may be followed by or truncated with a PRECHARGE command to the same bank (provided Auto Precharge was not activated). The PRECHARGE command should be issued X cycles after the READ command, where X equal the number of desired data-out element pairs.

Following the PRECHARGE command, a subsequent command to the same bank cannot be issued until tRP is met.

Note that part of the row precharge time is hidden during the access of the last data-out elements. In the case of a Read being executed to completion, a PRECHARGE command issued at the optimum time (as described above) provides the same operation that would result from Read burst with Auto Precharge enabled.

The disadvantage of the PRECHARGE command is that it requires that the command and address buses be available at the appropriate time to issue the command. The advantage of the PRECHARGE command is that it can be used to truncate bursts.

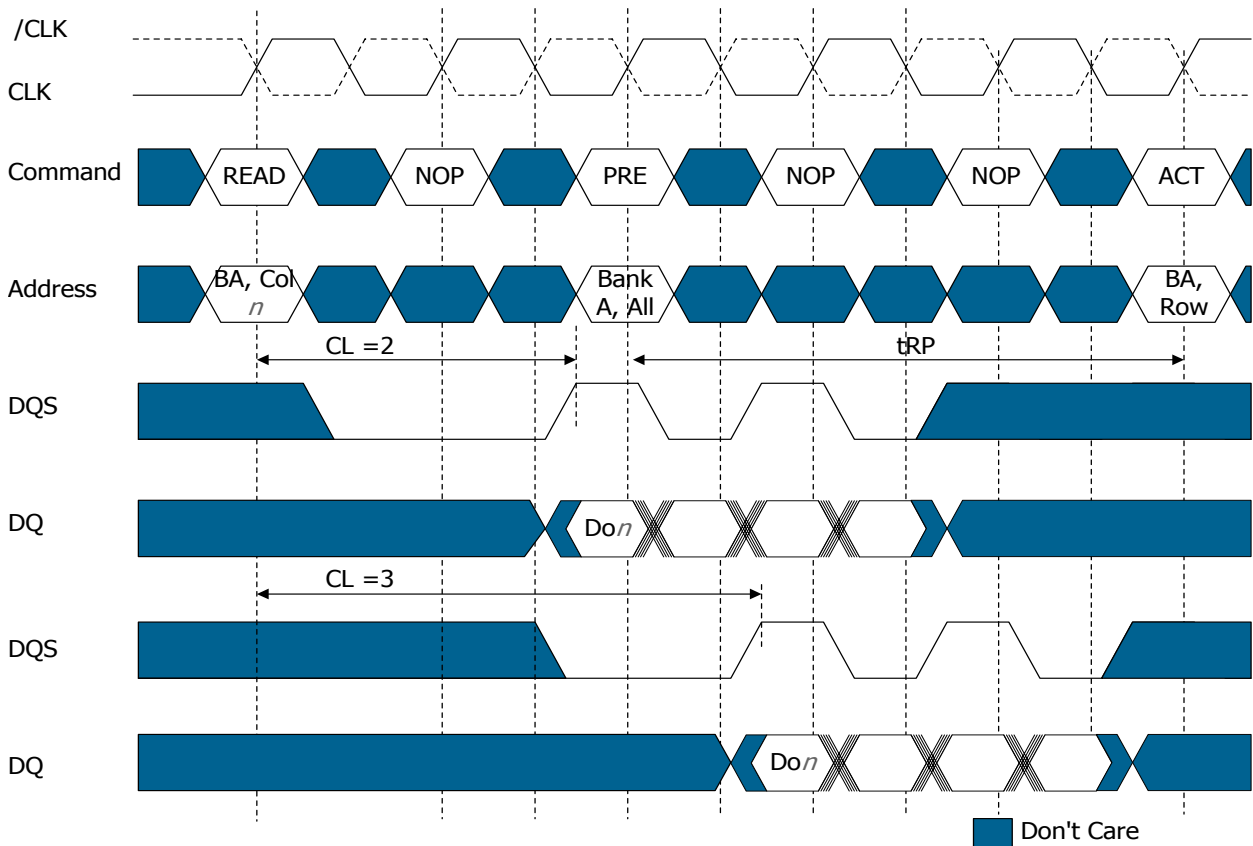

- 1) DO  $n$  = Data Out from column  $n$
- 2) Cases shown are either uninterrupted burst of 4, or interrupted bursts of 8 or 16
- 3) Shown with nominal tAC, tDQSK and tDQSQ
- 4) Precharge may be applied at (BL / 2) tCK after the READ command.
- 5) Note that Precharge may not be issued before tRAS ns after the ACTIVE command for applicable banks.
- 6) The ACTIVE command may be applied if tRC has been met.

### READ to PRECHARGE

### Write

Input data appearing on the data bus, is written to the memory array subject to the DM input logic level appearing coincident with the data. If a given DM signal is registered Low, the corresponding data will be written to the memory; if the DM signal is registered High, the corresponding data inputs will be ignored, and a write will not be executed to that byte / column location.

Basic Write timing parameters for DQs are shown in Figure; they apply to all Write operations.

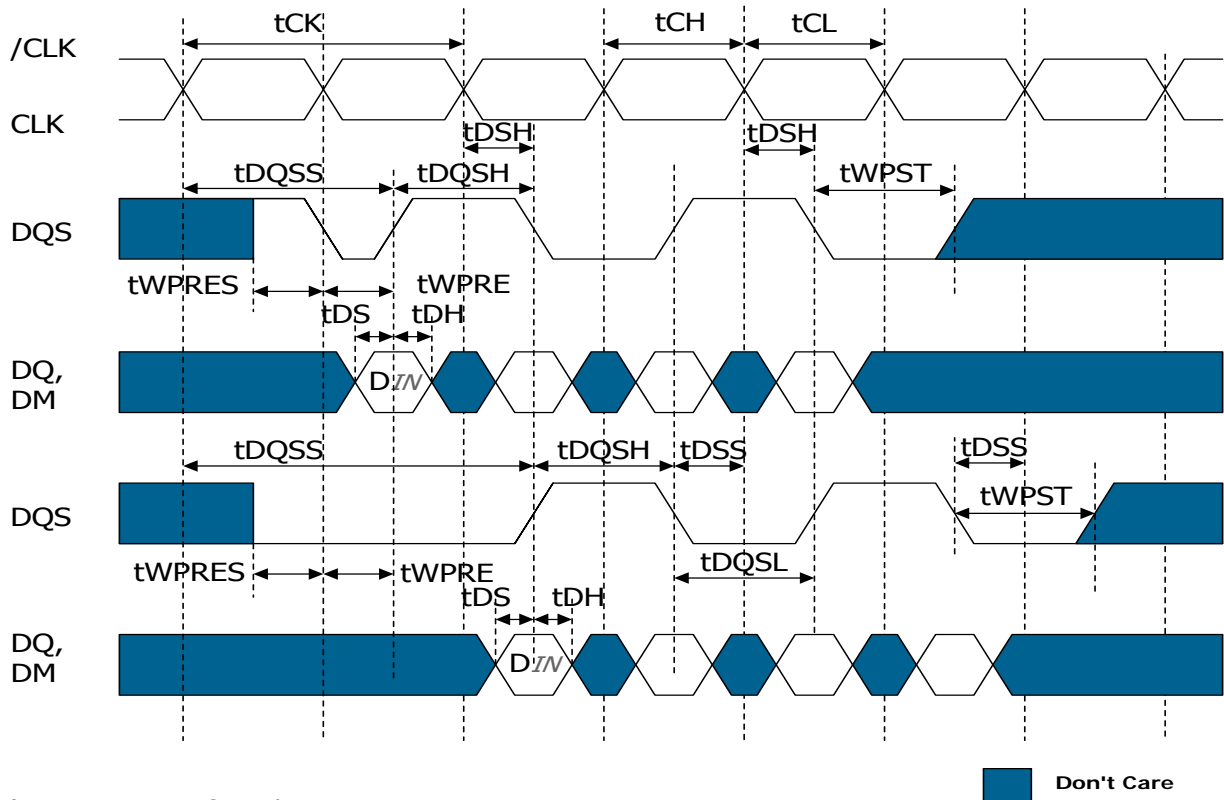

- 1)  $D_{IN}$ : Data in for column n
- 2) 3 subsequent elements of Data in are applied in the programmed order following  $D_{IN}$
- 3)  $t_{DQSS}$ : each rising edge of DQS must fall within the +/-25(percentage) Window of the corresponding positive clock edge

### Basic Write Timing Parameters

During Write bursts, the first valid data-in element will be registered on the first rising edge of DQS following the WRITE command, and the subsequent data elements will be registered on successive edges of DQS. The Low state of DQS between the WRITE command and the first rising edge is called the write preamble, and the Low state on DQS following the last data-in element is called the write postamble.

The time between the WRITE command and the first corresponding rising edge of DQS ( $t_{DQSS}$ ) is specified with a relatively wide range - from 75% to 125% of a clock cycle. Next fig. shows the two extremes of  $t_{DQSS}$  for a burst of 4. Upon completion of a burst, assuming no other commands have been initiated, the DQs will remain high-Z and any additional input data will be ignored.

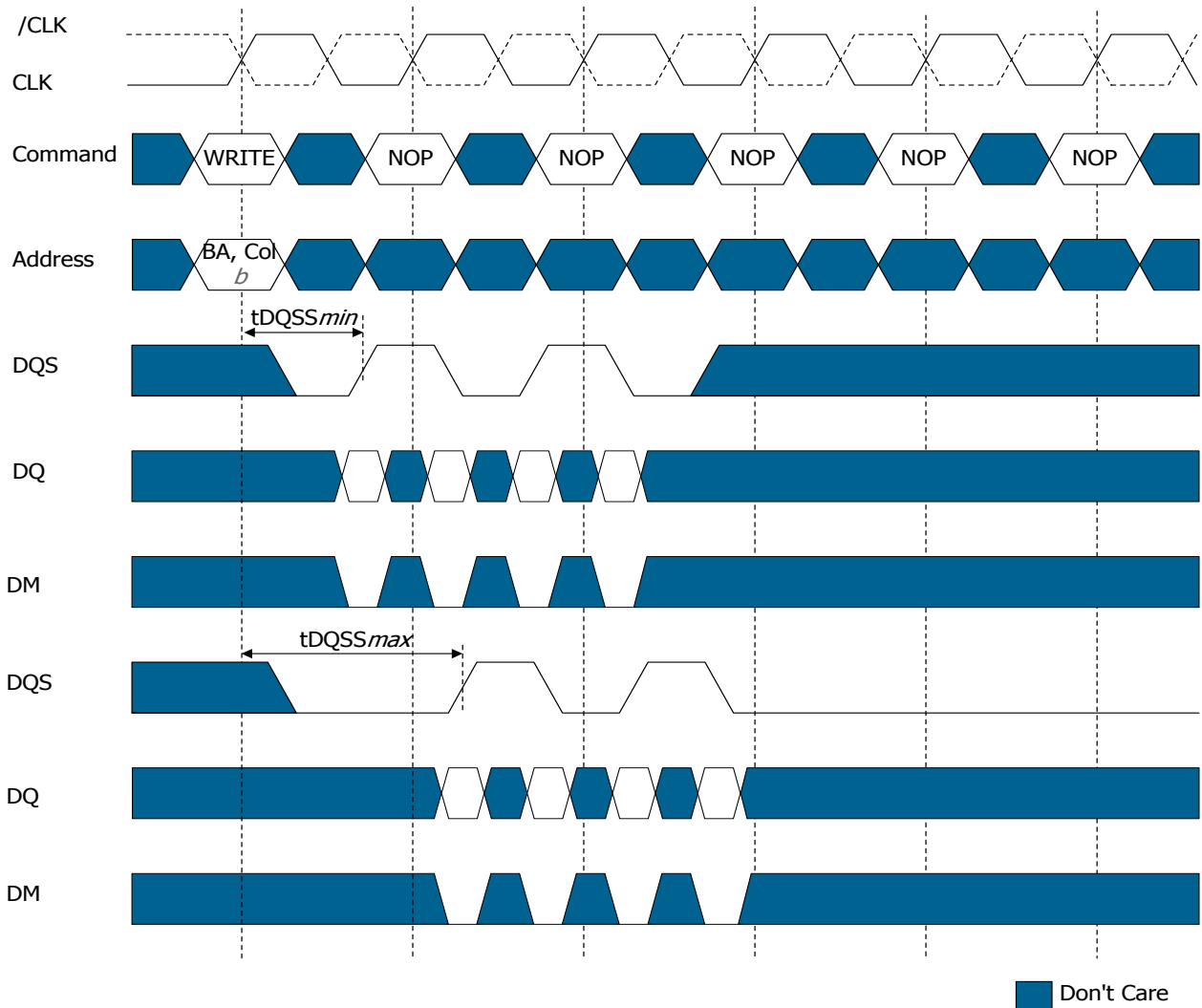

- 1) DO  $n$  = Data Out from column  $n$ ; DI  $b$  = Data In to column  $b$
- 2) Burst length = 4, 8 or 16 in the cases shown; if the burst length is 2, the BST command can be omitted
- 3) Shown with nominal  $tAC$ ,  $tDQCK$  and  $tDQSQ$

Write Burst (min. and max.  $tDQSS$ )

## WRITE to WRITE

Data for any WRITE burst may be concatenated with or truncated with a subsequent WRITE command. In either case, a continuous flow of input data, can be maintained. The new WRITE command can be issued on any positive edge of the clock following the previous WRITE command. The first data-in element from the new burst is applied after either the last element of a completed burst or the last desired data element of a longer burst which is being truncated. The new WRITE command should be issued X cycles after the first WRITE command, where X equals the number of desired data-in element pairs.

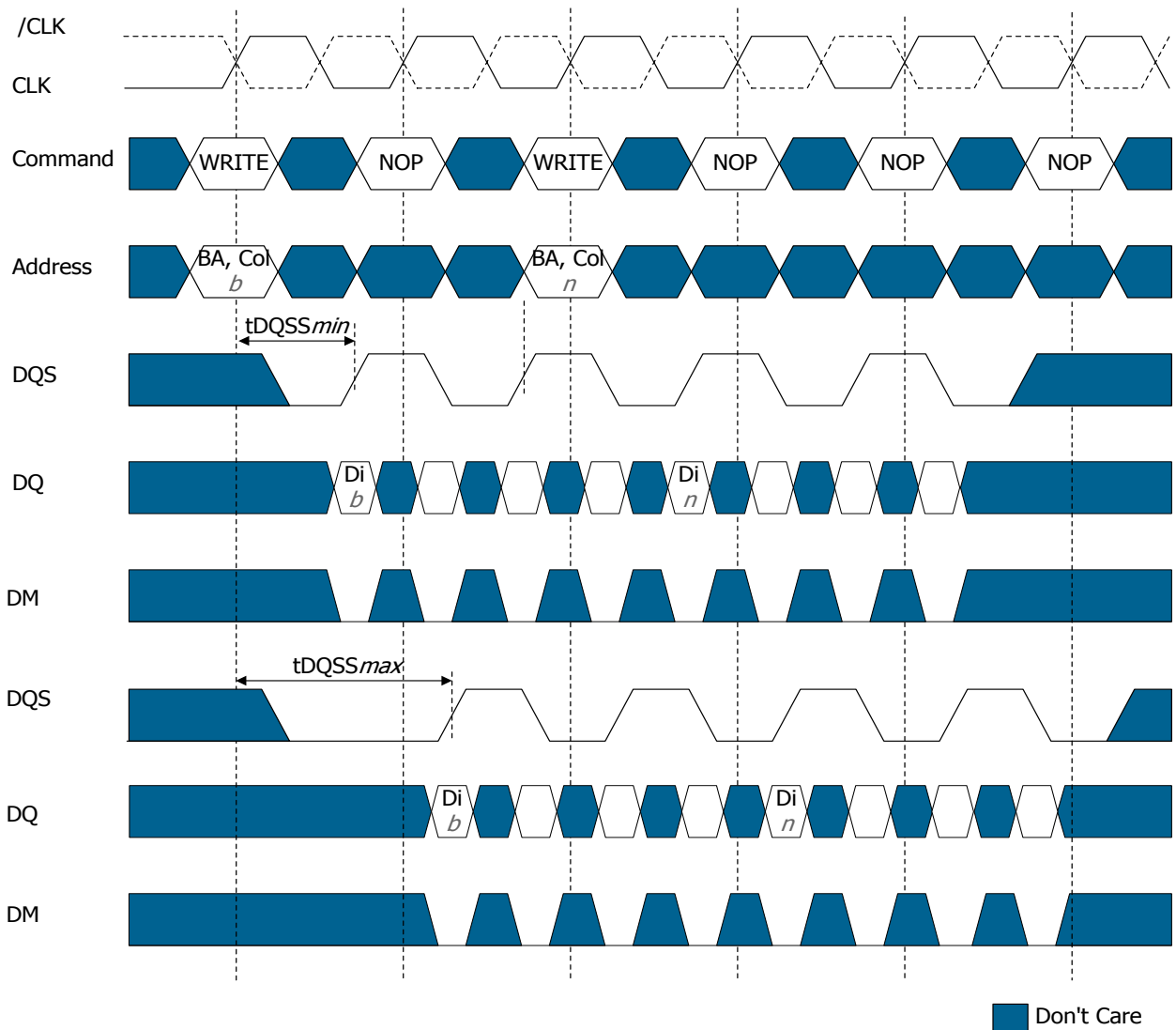

- 1)  $DI_{b(n)}$  = Data In to column b (column n)
- 2) 3 subsequent elements of Data In are applied in the programmed order following  $DI_b$ . 3 subsequent elements of Data In are applied in the programmed order following  $DI_n$ .
- 3) Non-interrupted bursts of 4 are shown.
- 4) Each WRITE command may be to any active bank

### Concatenated Write Bursts

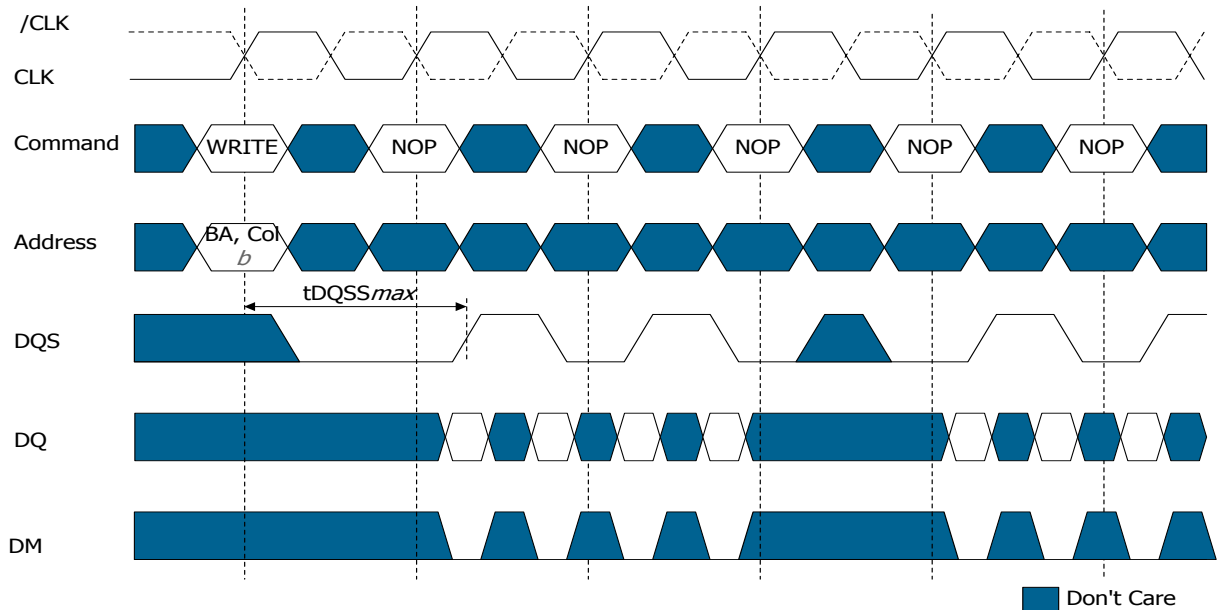

- 1) DI  $b(n)$  = Data In to column  $b$  (or column  $n$ ).
- 2) 3 subsequent elements of Data In are applied in the programmed order following DI  $b$ . 3 subsequent elements of Data In are applied in the programmed order following DI  $n$ .
- 3) Non-interrupted bursts of 4 are shown.
- 4) Each WRITE command may be to any active bank and may be to the same or different devices.

### Non-Concatenated Write Bursts

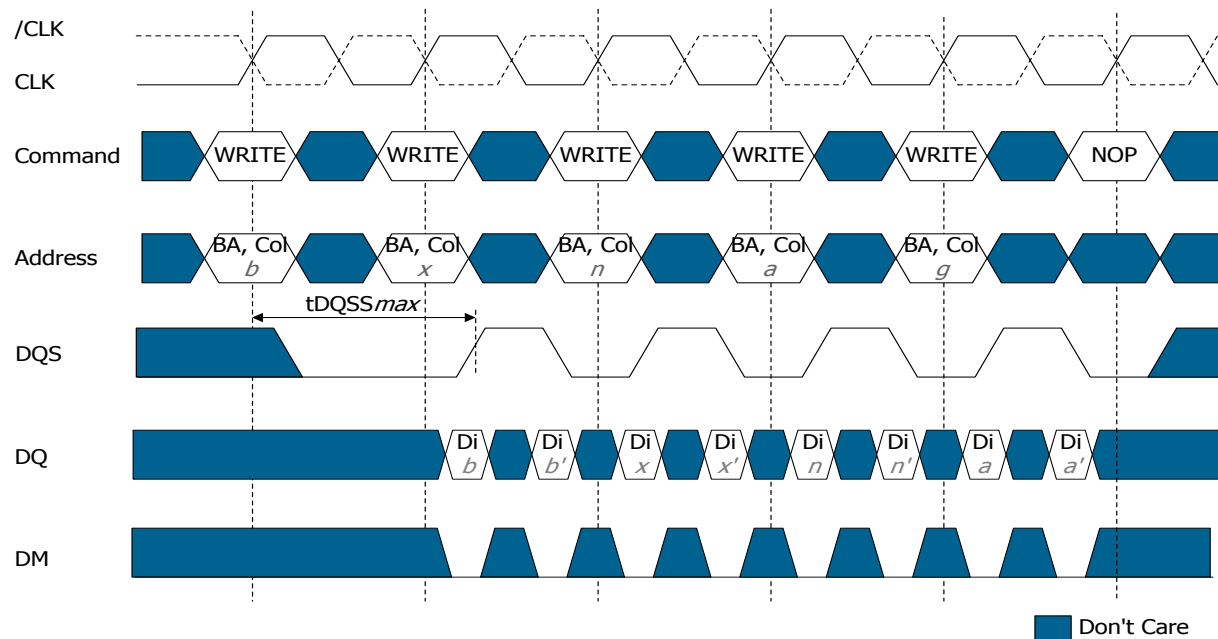

- 1) DI  $b$  etc. = Data In to column  $b$ , etc.  
       ;  $b'$ , etc. = the next Data In following DI  $b$ , etc. according to the programmed burst order
- 2) Programmed burst length = 2, 4, 8 or 16 in cases shown. If burst of 4, 8 or 16, burst would be truncated.
- 3) Each WRITE command may be to any active bank and may be to the same or different devices.

### Random Write Cycles

### WRITE to READ

Data for any Write burst may be followed by a subsequent READ command. To follow a Write without truncating the write burst,  $t_{WTR}$  should be met as shown in Figure.

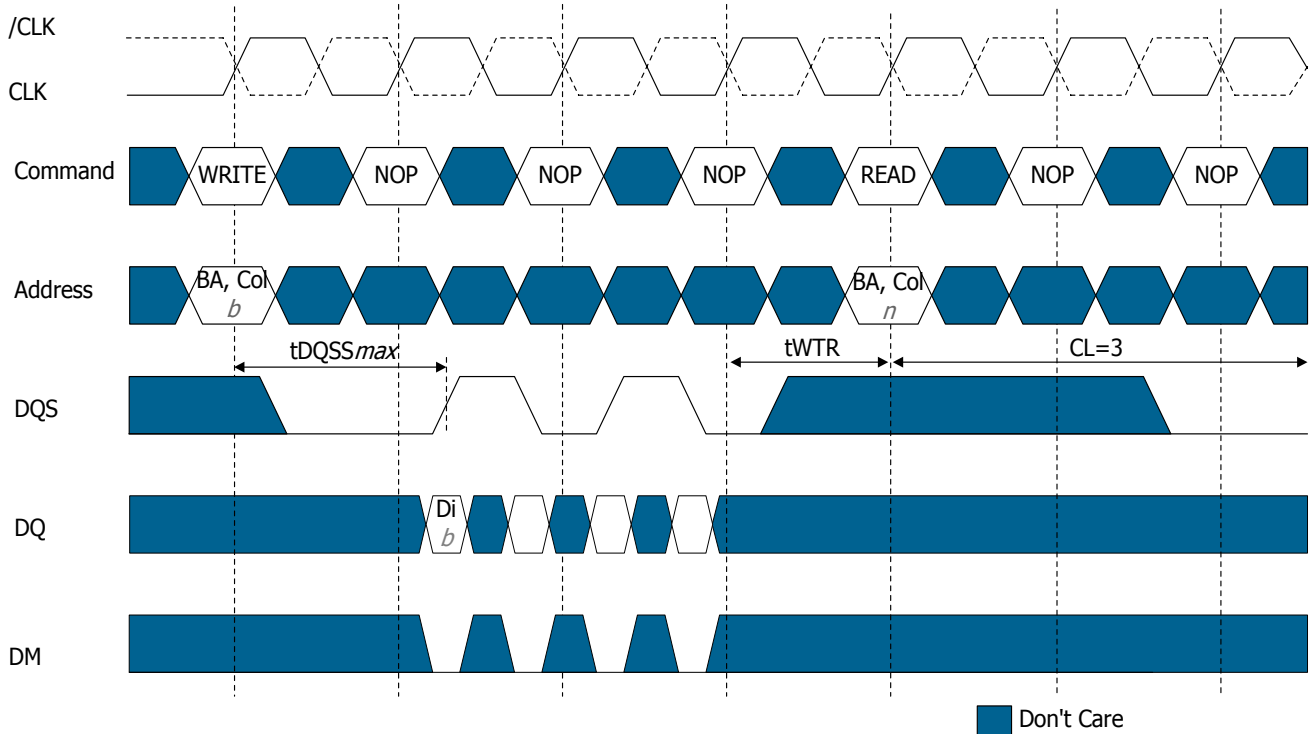

- 1)  $DI_b$  = Data In to column  $b$ . 3 subsequent elements of Data In are applied in the programmed order following  $DI_b$ .
- 2) A non-interrupted burst of 4 is shown.
- 3)  $t_{WTR}$  is referenced from the positive clock edge after the last Data In pair.
- 4) A10 is LOW with the WRITE command (Auto Precharge is disabled)
- 5) The READ and WRITE commands are to the same device but not necessarily to the same bank.

Data for any Write burst may be truncated by a subsequent READ command as shown in Figure. Note that the only data-in pairs that are registered prior to the  $t_{WTR}$  period are written to the internal array, and any subsequent data-in must be masked with DM.

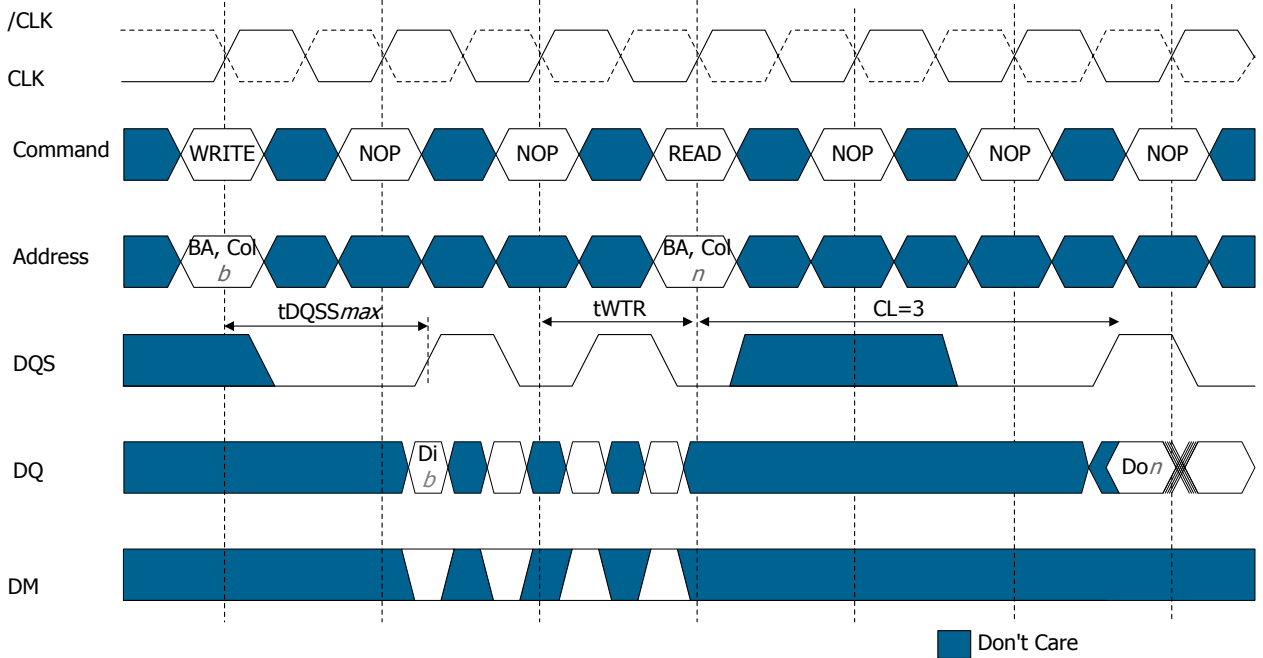

- 1) DI *b* = Data In to column *b*. DO *n* = Data Out from column *n*.
- 2) An interrupted burst of 4 is shown, 2 data elements are written. 3 subsequent elements of Data In are applied in the programmed order following DI *b*.
- 3) tWTR is referenced from the positive clock edge after the last Data In pair.
- 4) A10 is LOW with the WRITE command (Auto Precharge is disabled)
- 5) The READ and WRITE commands are to the same device but not necessarily to the same bank.

### Interrupting Write to Read

### WRITE to PRECHARGE

Data for any WRITE burst may be followed by a subsequent PRECHARGE command to the same bank (provided Auto Precharge was not activated). To follow a WRITE without truncating the WRITE burst,  $t_{WR}$  should be met as shown in Fig.

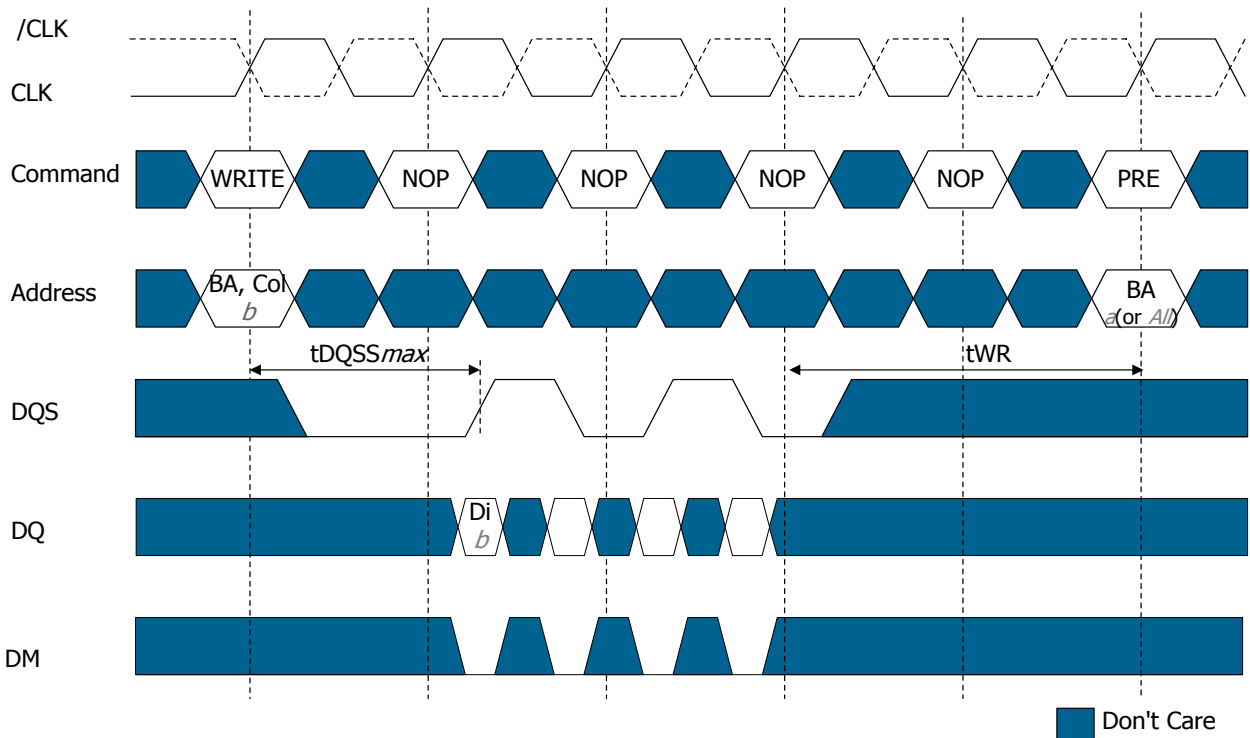

- 1) DI b (n) = Data In to column b (column n)
- 2) 3 subsequent elements of Data In are applied in the programmed order following DI b. 3 subsequent elements of Data In are applied in the programmed order following DI n.
- 3) Non-interrupted bursts of 4 are shown.
- 4) Each WRITE command may be to any active bank

### Non-Interrupting Write to Precharge

Data for any WRITE burst may be truncated by a subsequent PRECHARGE command as shown in Figure. Note that only data-in pairs that are registered prior to the  $t_{WR}$  period are written to the internal array, and any subsequent data-in should be masked with DM, as shown in next Fig. Following the PRECHARGE command, a subsequent command to the same bank cannot be issued until  $t_{RP}$  is met.

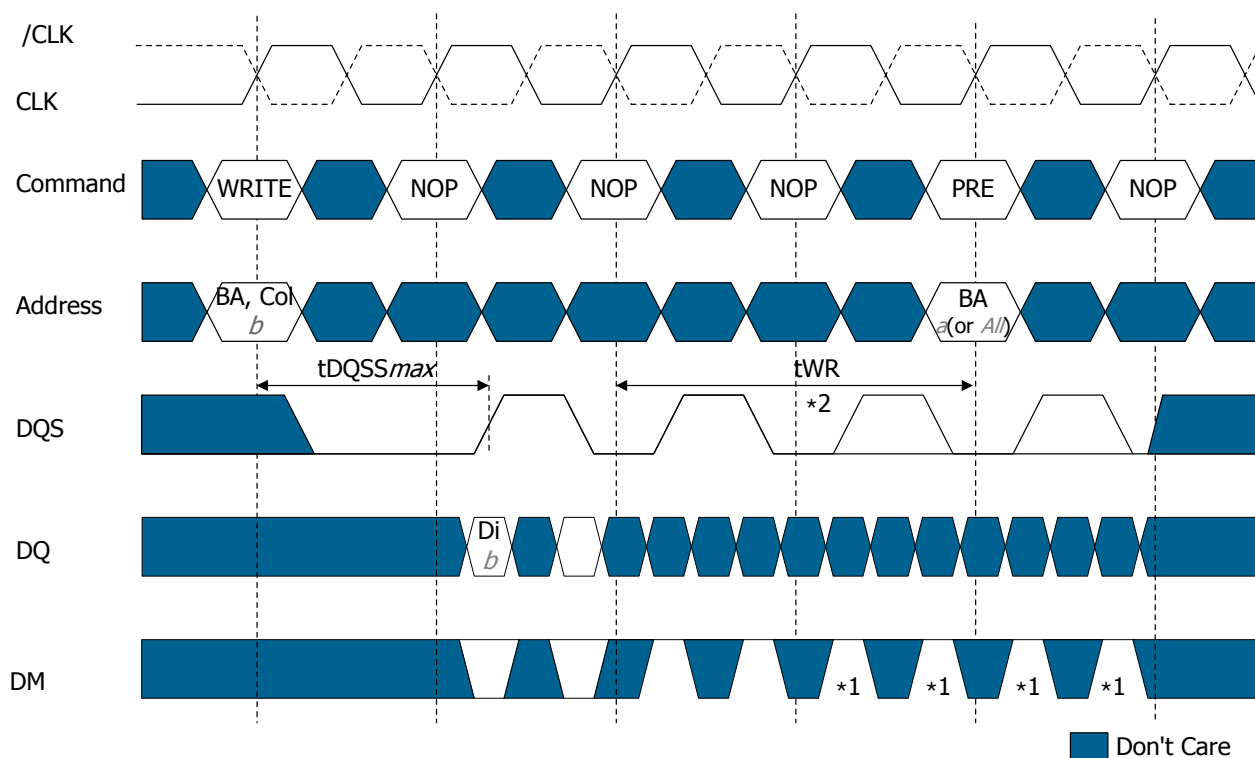

- 1) DI b = Data In to column b .
- 2) An interrupted burst of 4, 8 or 16 is shown, 2 data elements are written.
- 3)  $t_{WR}$  is referenced from the positive clock edge after the last desired Data In pair.
- 4) A10 is LOW with the WRITE command (Auto Precharge is disabled)
- 5) \*1 = can be Don't Care for programmed burst length of 4
- 6) \*2 = for programmed burst length of 4, DQS becomes Don't Care at this point

### Interrupting Write to Precharge

### BURST TERMINATE

The BURST TERMINATE command is used to truncate read bursts (with autoprecharge disabled). The most recently registered READ command prior to the BURST TERMINATE command will be truncated, as shown in the Operation section of this datasheet. Note the BURST TERMINATE command is not bank specific. This command should not be used to terminate write bursts.

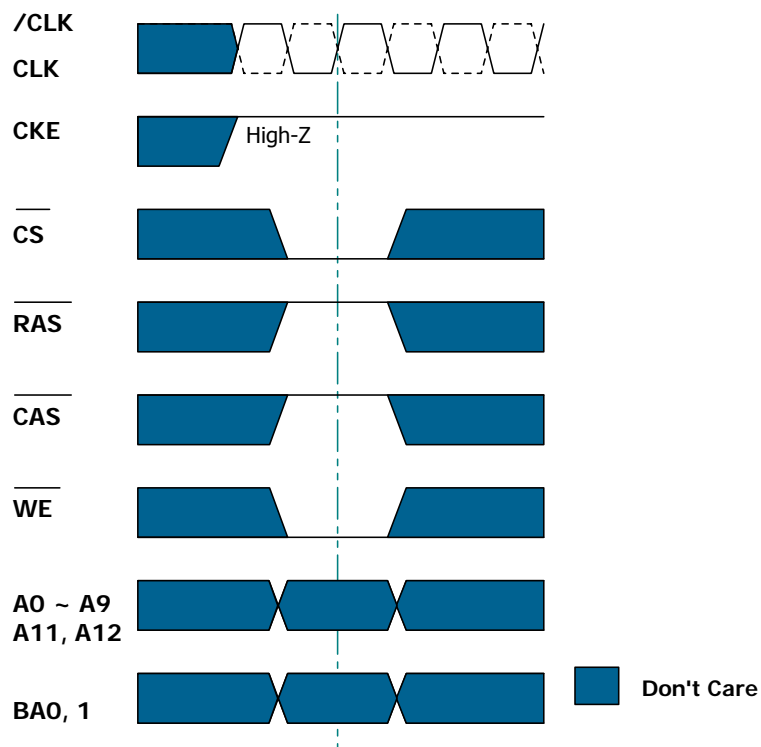

BURST TERMINATE COMMAND

### PRECHARGE

The PRECHARGE command is used to deactivate the open row in a particular bank or the open row in all banks. Another command to the same bank (or banks) being precharged must not be issued until the precharge time ( $t_{RP}$ ) is completed.

If one bank is to be precharged, the particular bank address needs to be specified. If all banks are to be precharged, A10 should be set high along with the PRECHARGE command. If A10 is high, BA0 and BA1 are ignored. A PRECHARGE command will be treated as a NOP if there is no open row in that bank, or if the previously open row is already in the process of precharging.

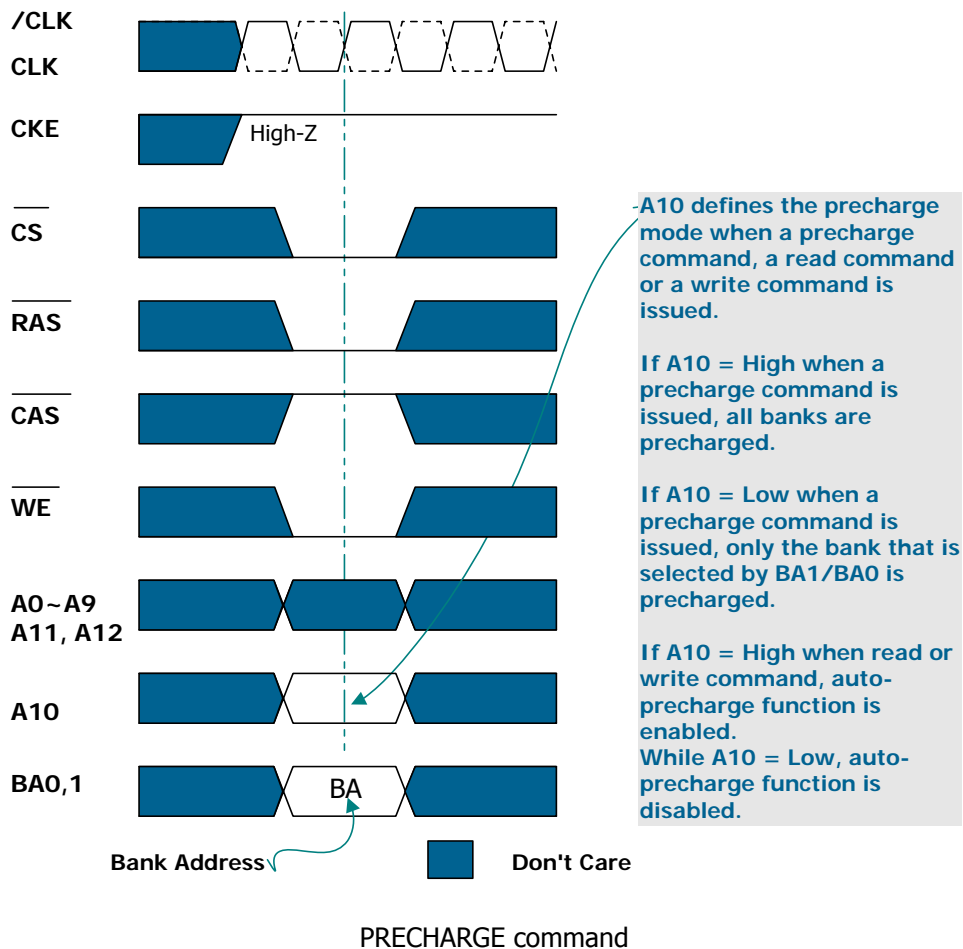

### AUTO PRECHARGE

Auto Precharge is a feature which performs the same individual bank precharge function as described above, but without requiring an explicit command.

This is accomplished by using A10 (A10=high), to enable auto precharge in conjunction with a specific Read or Write command. This precharges the bank/row after the Read or Write burst is complete.

Auto precharge is non persistent, so it should be enabled with a Read or Write command each time auto precharge is desired. Auto precharge ensures that a precharge is initiated at the earliest valid stage within a burst.

The user must not issue another command to the same bank until the precharge time ( $t_{RP}$ ) is completed.

## AUTO REFRESH AND SELF REFRESH

Mobile DDR devices require a refresh of all rows in any rolling 64ms interval. Each refresh is generated in one of two ways: by an explicit AUTO REFRESH command, or by an internally timed event in SELF REFRESH mode:

### - AUTO REFRESH.

This command is used during normal operation of the Mobile DDR. It is non persistent, so must be issued each time a refresh is required. The refresh addressing is generated by the internal refresh controller. The Mobile DDR requires AUTO REFRESH commands at an average periodic interval of  $t_{REFI}$ .

To allow for improved efficiency in scheduling and switching between tasks, some flexibility in the absolute refresh interval is provided. A maximum of eight AUTO REFRESH commands can be posted to any given Mobile DDR, and the maximum absolute interval between any AUTO REFRESH command and the next AUTO REFRESH command is  $8 * t_{REFI}$ .

### -SELF REFRESH.

This state retains data in the Mobile DDR, even if the rest of the system is powered down (even without external clocking). Note refresh interval timing while in Self Refresh mode is scheduled internally in the Mobile DDR and may vary and may not meet  $t_{REFI}$  time.

"Don't Care" except CKE, which must remain low. An internal refresh cycle is scheduled on Self Refresh entry. The procedure for exiting Self Refresh mode requires a series of commands. First clock must be stable before CKE going high. NOP commands should be issued for the duration of the refresh exit time ( $t_{XSR}$ ), because time is required for the completion of any internal refresh in progress.

The use of SELF REFRESH mode introduces the possibility that an internally timed event can be missed when CKE is raised for exit from self refresh mode. Upon exit from SELF REFRESH an extra AUTO REFRESH command is recommended. In the self refresh mode, two additional power-saving options exist. They are Temperature Compensated Self Refresh and Partial Array Self Refresh and are described in the Extended Mode Register section.

The Self Refresh command is used to retain cell data in the Mobile SDRAM. In the Self Refresh mode, the Mobile SDRAM operates refresh cycle asynchronously.

The Self Refresh command is initiated like an Auto Refresh command except CKE is disabled(Low). The Mobile DDR can accomplish a special Self Refresh operation by the specific modes(PASR) programmed in extended mode registers. The Mobile DDR can control the refresh rate automatically by the temperature value of Auto TCSR(Temperature Compensated Self Refresh) to reduce self refresh current and select the memory array to be refreshed by the value of PASR(Partial Array Self Refresh). The Mobile DDR can reduce the self refresh current( $IDD6$ ) by using these two modes.

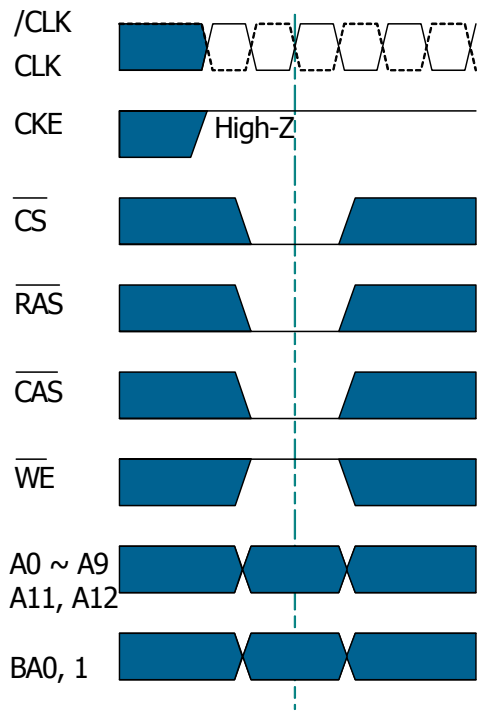

Auto-Refresh Command

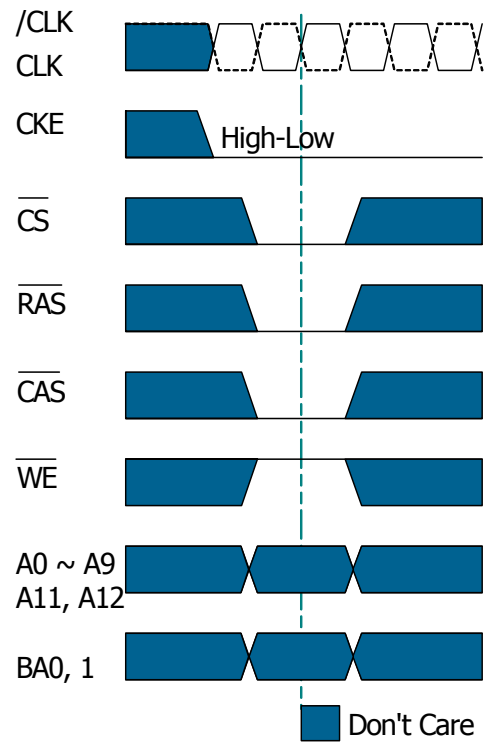

Self-Refresh Command

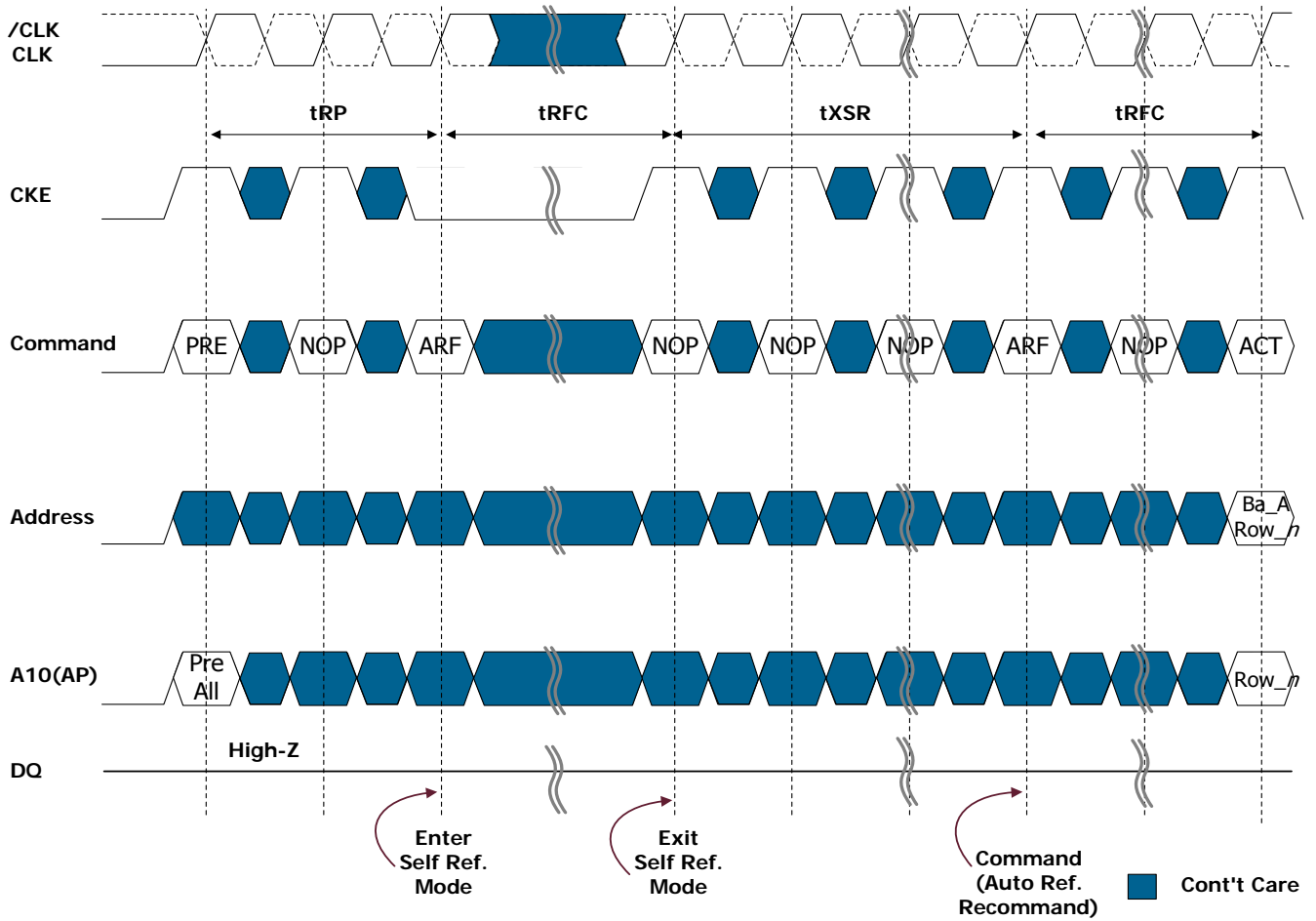

SELF-REFRESH ENTRY AND EXIT

### MODE REGISTER SET

The mode registers are loaded via the address bits.

BA0 and BA1 are used to select between the Mode Register and the Extended Mode Register. See the Mode Register description in the register definition section. The MODE REGISTER SET command can only be issued when all banks are idle and no bursts are in progress, and a subsequent executable command cannot be issued until tMRD is met.

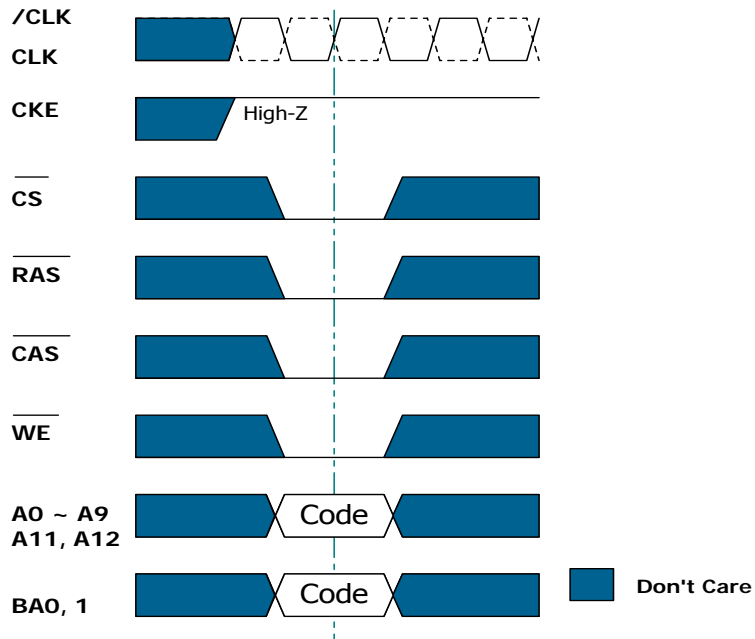

### MODE REGISTER SET COMMAND

Note:

BA0=BA1=Low loads the Mode Register, whereas BA0=Low and BA1=High loads the Extended Mode Register.

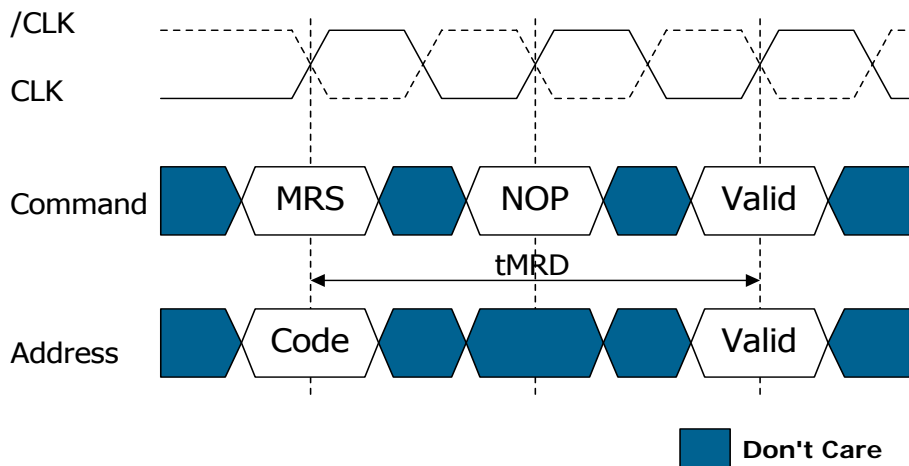

Code = Mode Register / Extended Mode Register selection  
 (BA0, BA1) and op-code (A0 - An)

### tMRD DEFINITION

### POWER DOWN

Power down occurs if CKE is set low coincident with Device Deselect or NOP command and when no accesses are in progress. If power down occurs when all banks are idle, it is Precharge Power Down.

If Power down occurs when one or more banks are Active, it is referred to as Active power down. The device cannot stay in this mode for longer than the refresh requirements of the device, without losing data. The power down state is exited by setting CKE high while issuing a Device Deselect or NOP command.

A valid command can be issued after tXP. For Clock stop during power down mode, please refer to the Clock Stop subsection in Operation section of this datasheet. (Page 57)

**NOTE:**

This case shows CKE low coincident with NO OPERATION.

Alternately POWER DOWN entry can be achieved with CKE low coincident with Device DESELECT.

### DEEP POWER-DOWN

The Deep Power-Down (DPD) mode enables very low standby currents. All internal voltage generators inside the LPDDR are stopped and all memory data is lost in this mode.

All the information in the Mode Register and the Extended Mode Register is lost. Next Figure, *DEEP POWER-DOWN COMMAND* shows the DEEP POWER-DOWN command. All banks must be in idle state with no activity on the data bus prior to entering the DPD mode. While in this state, CKE must be held in a constant low state.

To exit the DPD mode, CKE is taken high after the clock is stable and NOP command must be maintained for at least 200 us. After 200 us a complete re-initialization routing is required following steps 4 through 11 as defined for the initialization sequence. (Page 61, 62)

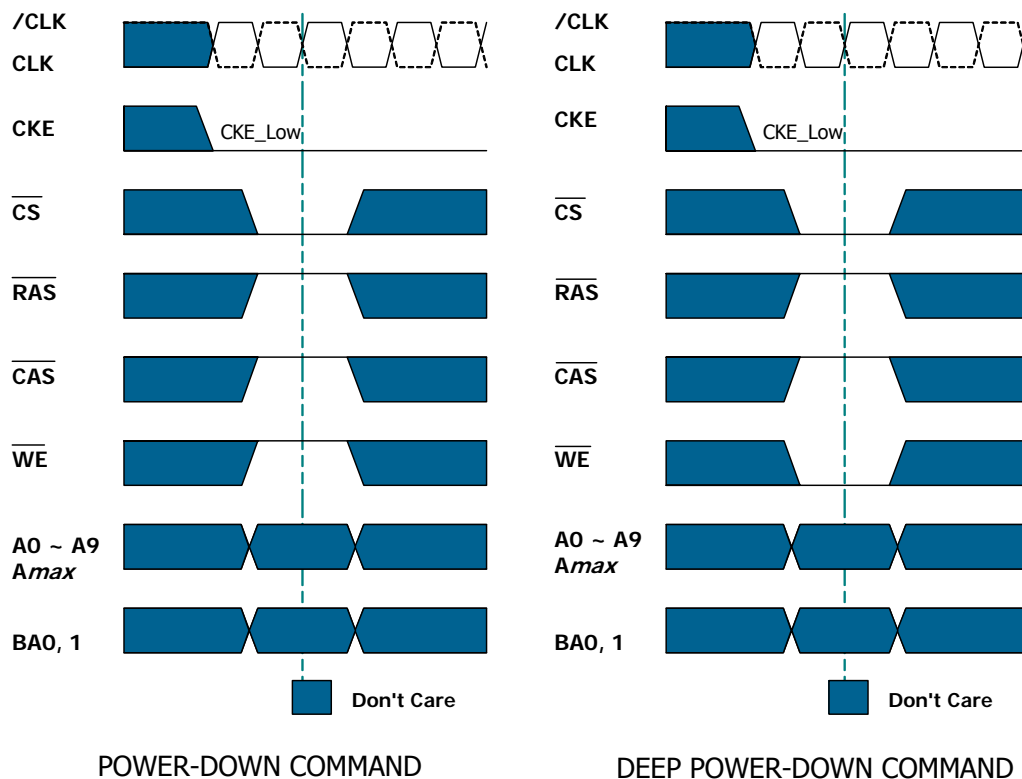

**Mobile DDR SDRAM Deep Power-Down Entry and Exit**

Before entering deep power down the DRAM must be in an all banks idle state with no activity on the data bus. Upon entering deep power down all data will be lost. While in deep power down CKE must be held in a constant low state. Upon exiting deep power down NOP command must be maintained for 200us. After 200us a complete initialization routine is required following steps 4 through 11 as defined for the initialization sequence. Steps follow (See Page46, 47)

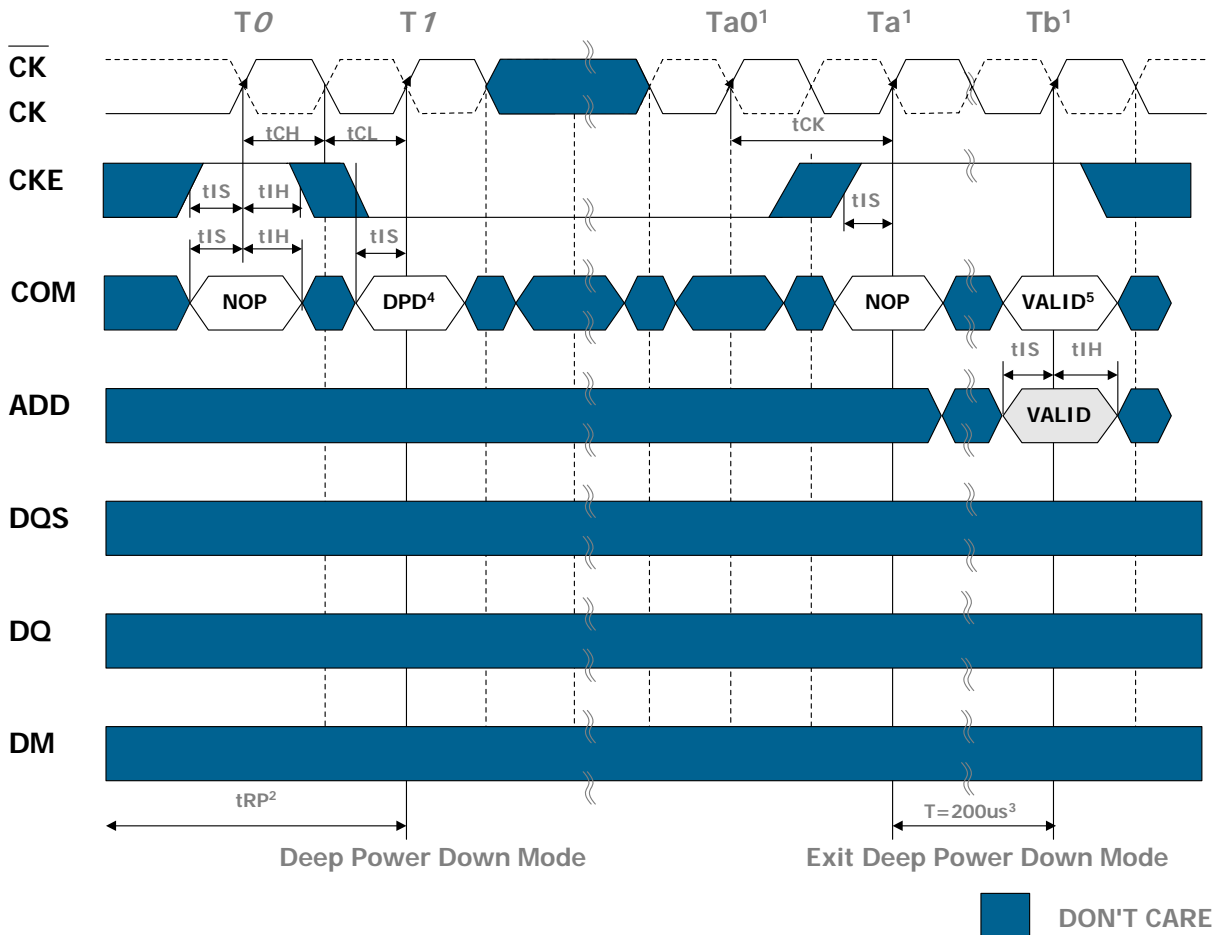

**Figure 5. Mobile DDR SDRAM Deep Power-Down Entry and Exit**

**Note**

1. Clock must be stable before exiting deep power down mode. That is, the clock must be cycling within specifications by Ta0.
2. Device must be in the all banks idle state prior to entering Deep Power Down mode.
3. 200us is required before any command can be applied upon exiting DPD.
4. DPD = Deep Power Down command.
5. Upon exiting Deep Power Down a precharge all command must be issued followed by two auto refresh commands and a load mode register sequence.

## FUNCTION OF Mobile DDR SDRAM

### POWER-UP SEQUENCE AND DEVICE INITIALIZATION

Mobile DDR SDRAM must be powered up and initialized in a predefined manner. Power must be applied to VDD and VDDQ(simultaneously). The clock signal must be started at the same time. After power up, an initial pause of 200 usec is required. And a precharge all command will be issued to the Mobile DDR. Then, 8 or more Auto refresh cycles will be provided. After the Auto refresh cycles are completed, a mode register set(MRS) command will be issued to program the specific mode of operation (Cas Latency, Burst length, etc.) And an extended mode register set command will be issued to program specific mode of self refresh operation(PASR). The following these cycles, the Mobile SDRAM is ready for normal operation. To ensure device functionality, there is a predefined sequence that must occur at device power up or if there is any interruption of device power. Steps follow (See Page60, 61)

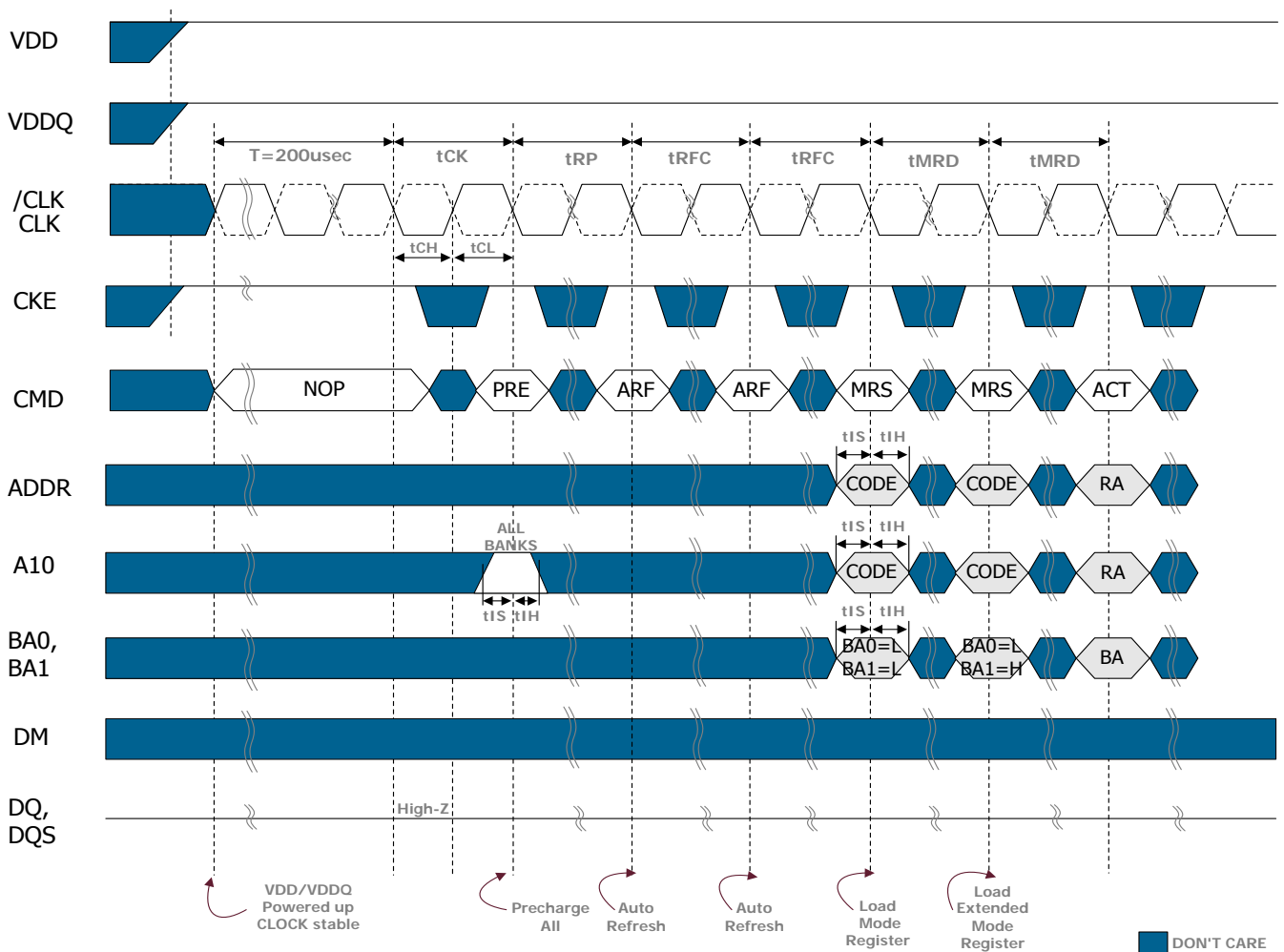
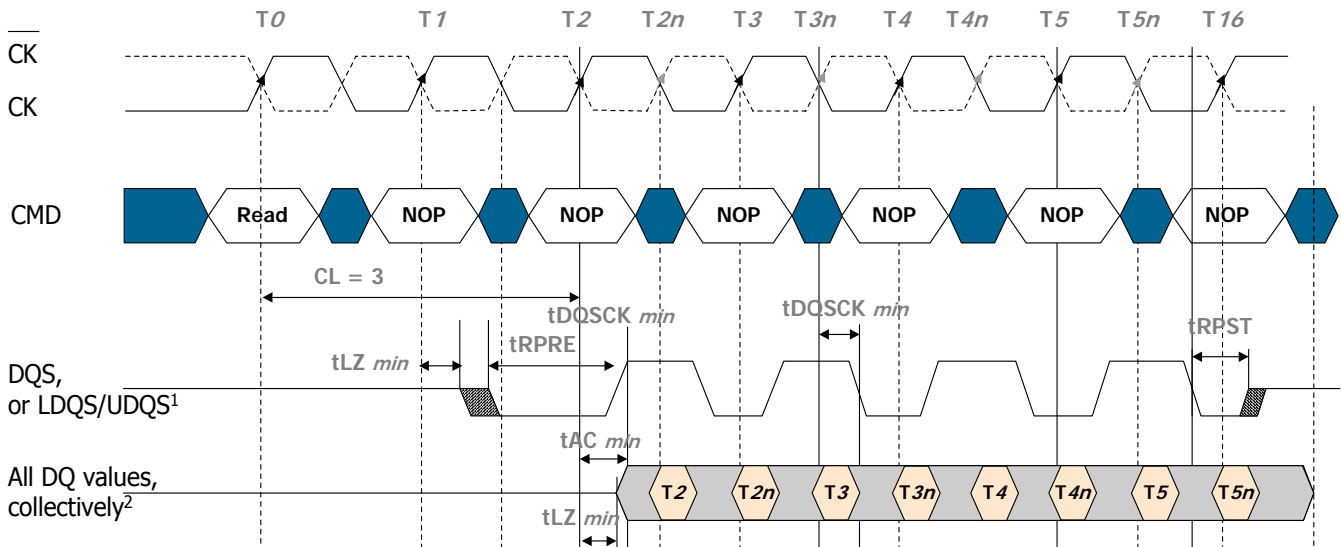

Figure 1. Initialization Waveform Sequence

**CAS LATENCY DEFINITION**

CAS latency definition of Mobile DDR SDRAM must be must be loaded when all banks are idle, and the controller must wait the specified time before initiating the subsequent operation.

CAS latency definition: with CL = 3 the first data element is valid at (2 \* tCK + tAC) after the clock at which the READ command was registered (See Figure 2)



**Figure 2. CAS LATENCY DEFINITION**

**NOTE**

1. DQ transitioning after DQS transition define tDQSQ window.
2. All DQ must transition by tDQSQ after DQS transitions, regardless of tAC.
3. tAC is the DQ output window relative to CK, and is the long term component of DQ skew.

### Clock Stop Mode

Clock stop mode is a feature supported by Mobile DDR SDRAM devices. It reduces clock-related power consumption during idle periods of the device.

Conditions: the Mobile DDR SDRAM supports clock stop in case:

- The last access command (ACTIVE, READ, WRITE, PRECHARGE, AUTO REFRESH or MODE REGISTER SET) has executed to completion, including any data-out during read bursts; the number of required clock pulses per access command depends on the device's AC timing parameters and the clock frequency;
- The related timing condition ( $t_{RCD}$ ,  $t_{WR}$ ,  $t_{RP}$ ,  $t_{RFC}$ ,  $t_{MRD}$ ) has been met;
- CKE is held HIGH.

When all conditions have been met, the device is either in "idle" or "row active" state, and clock stop mode may be entered with CK held LOW and  $\overline{CK}$  held HIGH. Clock stop mode is exited when the clock is restarted. NOPs command have to be issued for at least one clock cycle before the next access command may be applied. Additional clock pulses might be required depending on the system characteristics.

Figure1 illustrates the clock stop mode:

- Initially the device is in clock stop mode;
- The clock is restarted with the rising edge of  $T_0$  and a NOP on the command inputs;
- With  $T_1$  a valid access command is latched; this command is followed by NOP commands in order to allow for clock stop as soon as this access command has completed;
- $T_n$  is the last clock pulse required by the access command latched with  $T_1$ .
- The timing condition of this access command is met with the completion of  $T_n$ , therefore  $T_n$  is the last clock pulse required by this command and the clock is then stopped.

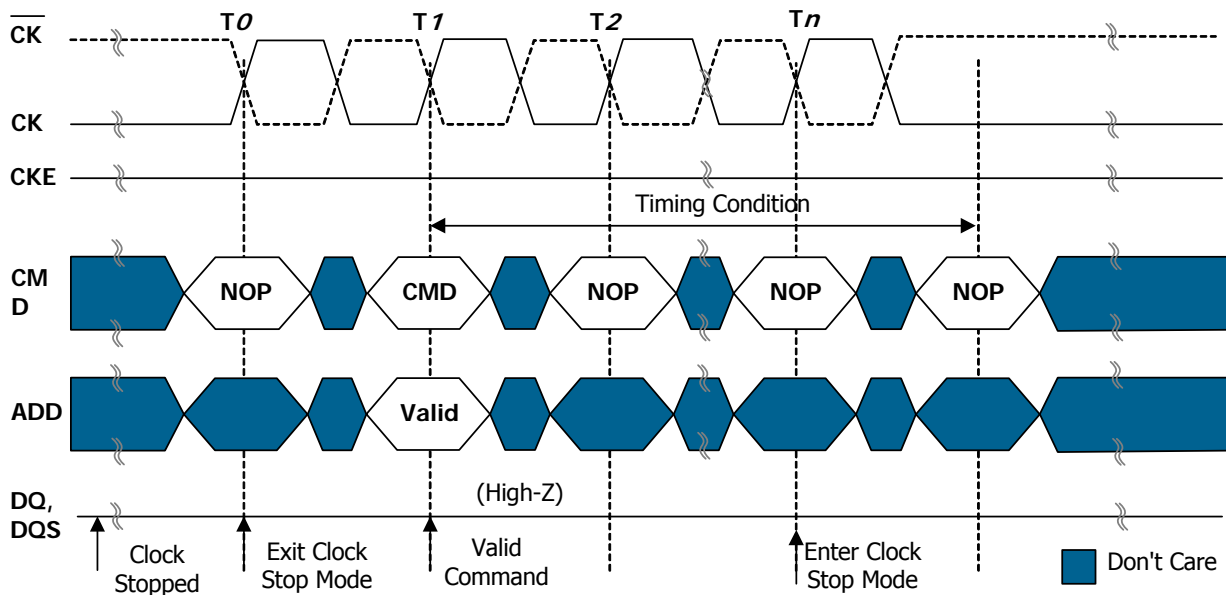
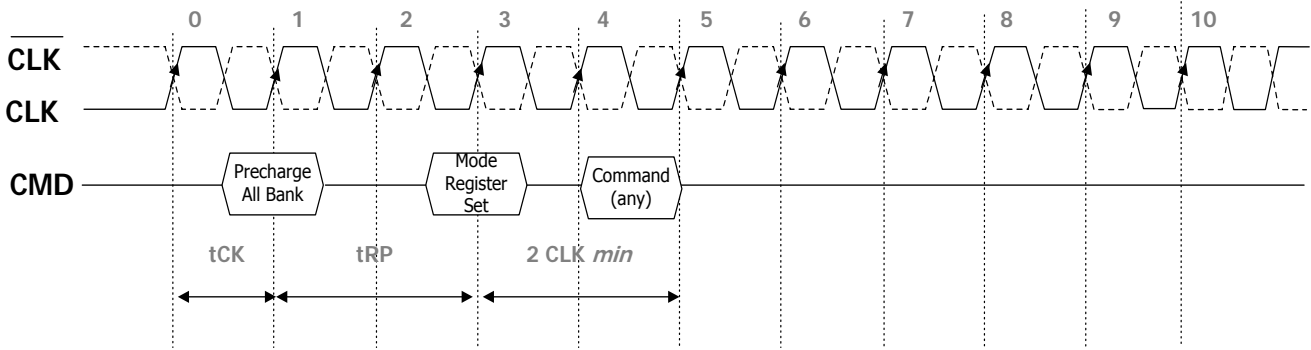

Figure 3. Clock Stop Mode

**Mode Register**

The mode register contains the specific mode of operation of the Mobile DDR SDRAM. This register includes the selection of a burst length( 2, 4, 8, 16), a cas latency(2, 3 or 4), a burst type. The mode register set must be done before any activate command after the power up sequence. Any contents of the mode register be altered by re-programming the mode register through the execution of mode register set command.



**Figure 4. Mode Register Set**

**BURST LENGTH**

Read and write accesses to the Mobile DDR SDRAM are burst oriented, with the burst length being programmable, as shown in Page10. The burst length determines the maximum number of column locations that can be accessed for a given READ or WRITE command. Burst lengths of 2, 4, 8 or 16 locations are available for both the sequential and the interleaved burst types.

**BURST TYPE**

Accesses within a given burst may be programmed to be either sequential or interleaved.

**CAS LATENCY**

The CAS latency is the delay between the registration of a READ command and the availability of the first piece of output data. The latency should be set to 3 clocks. If a READ command is registered at a clock edge  $n$  and the latency is 3 clocks, the first data element will be valid at  $n + 2tCK + tAC$ . If a READ command is registered at a clock edge  $n$  and the latency is 2 clocks, the first data element will be valid at  $n + tCK + tAC$ .

**Data mask<sup>1,2)</sup>**

Mobile DDR SDRAM uses a DQ write mask enable signal (DM) which masks write data.

Data masking is only available in the write cycle for Mobile DDR SDRAM. Data masking is available during write, but data masking during read is not available.

DM command masks burst write data with reference to data strobe signal and it is not related with read data. DM command can be initiated at both the rising edge and the falling edge of the DQS. DM latency for write operation is zero. For x16 data I/O, DDR SDRAM is equipped with LDM and UDM which control lower byte (DQ0~DQ7) and upper byte (DQ8~DQ15) respectively.

Note 1) : Mobile SDR can mask both read and write data, but the read mask is not supported by Mobile DDR.

2) : Differences in Functions and Specifications (next table)

| Item      | Mobile DDR      | Mobile SDR           |
|-----------|-----------------|----------------------|
| Data mask | Write mask only | Write mask/Read mask |

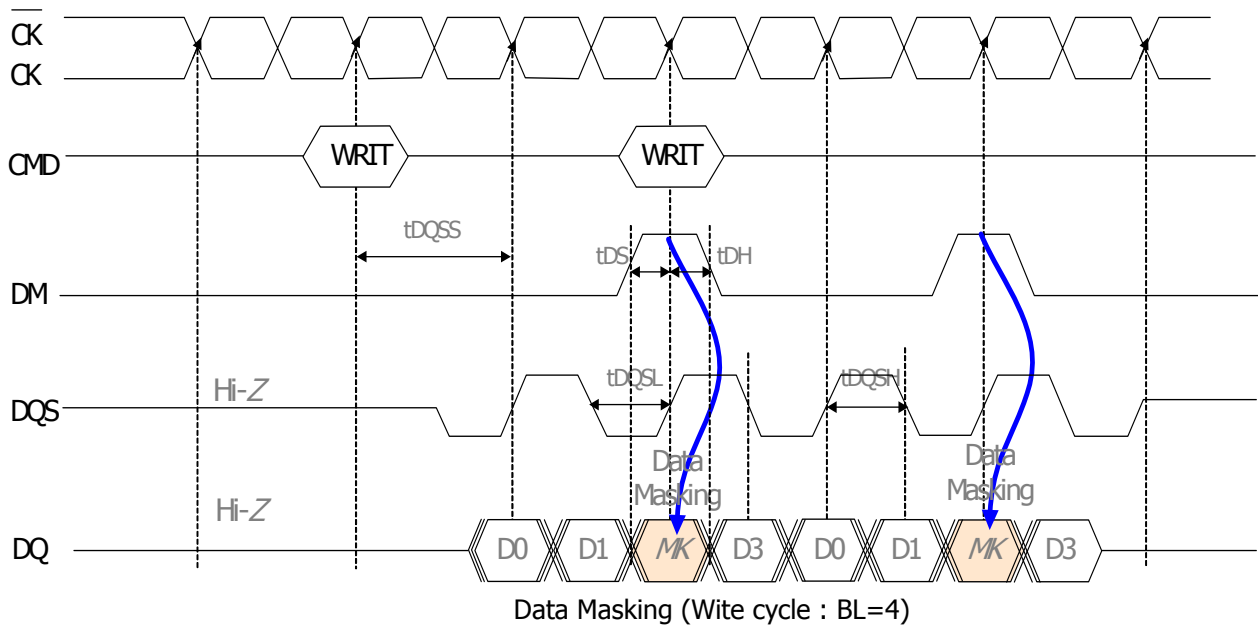

### **Extended Mode Register**

The Extended Mode Register contains the specific features of self refresh operation of the Mobile DDR SDRAM.

The Extended Mode Register is programmed via the MODE REGISTER SET command (with BA1=1 and BA0=0) and will retain the stored information until it is reprogrammed, the device is put in Deep Power-Down mode, or the device loses power. The Extended Mode Register should be loaded when all Banks are idle and no bursts are in progress, and subsequent operation should only be initiated after tMRD. Violating these requirements will result in unspecified operation.

The Extended Mode Register is written by asserting low on  $\overline{CS}$ ,  $\overline{RAS}$ ,  $\overline{CAS}$ ,  $\overline{WE}$  and high on BA0. The state of address pins A0 ~ A11 and BA1 in the same cycle as  $\overline{CS}$ ,  $\overline{RAS}$ ,  $\overline{CAS}$  and  $\overline{WE}$  going low are written in the extended mode register. The Extended Mode Register must be loaded when all banks are idle and no bursts are in progress, and the controller must wait the specified time before initiating any subsequent operation. Violating either of these requirements will result in unspecified operation.

This register includes the selection of partial arrays to be refreshed (half array, quarter array, etc.). The extended mode register set must be done before any activate command after the power up sequence. Any contents of the mode register be altered by re-programming the mode register through the execution of extended mode register set command.

### **PARTIAL ARRAY SELF-REFRESH (PASR)**

With PASR, the self refresh may be restricted to a variable portion of the total array. The whole array (default), 1/2 array, or 1/4 array could be selected.

### **DRIVE STRENGTH (DS)**

The drive strength could be set to full or half via address bits A5 and A6. The half drive strength is intended for lighter loads or point-to-point environments.

**Mobile DDR SDRAM Deep Power-Down Entry and Exit**

Before entering deep power down the DRAM must be in an all banks idle state with no activity on the data bus. Upon entering deep power down all data will be lost. While in deep power down CKE must be held in a constant low state. Upon exiting deep power down NOP command must be maintained for 200us. After 200us a complete initialization routine is required following steps 4 through 11 as defined for the initialization sequence. Steps follow

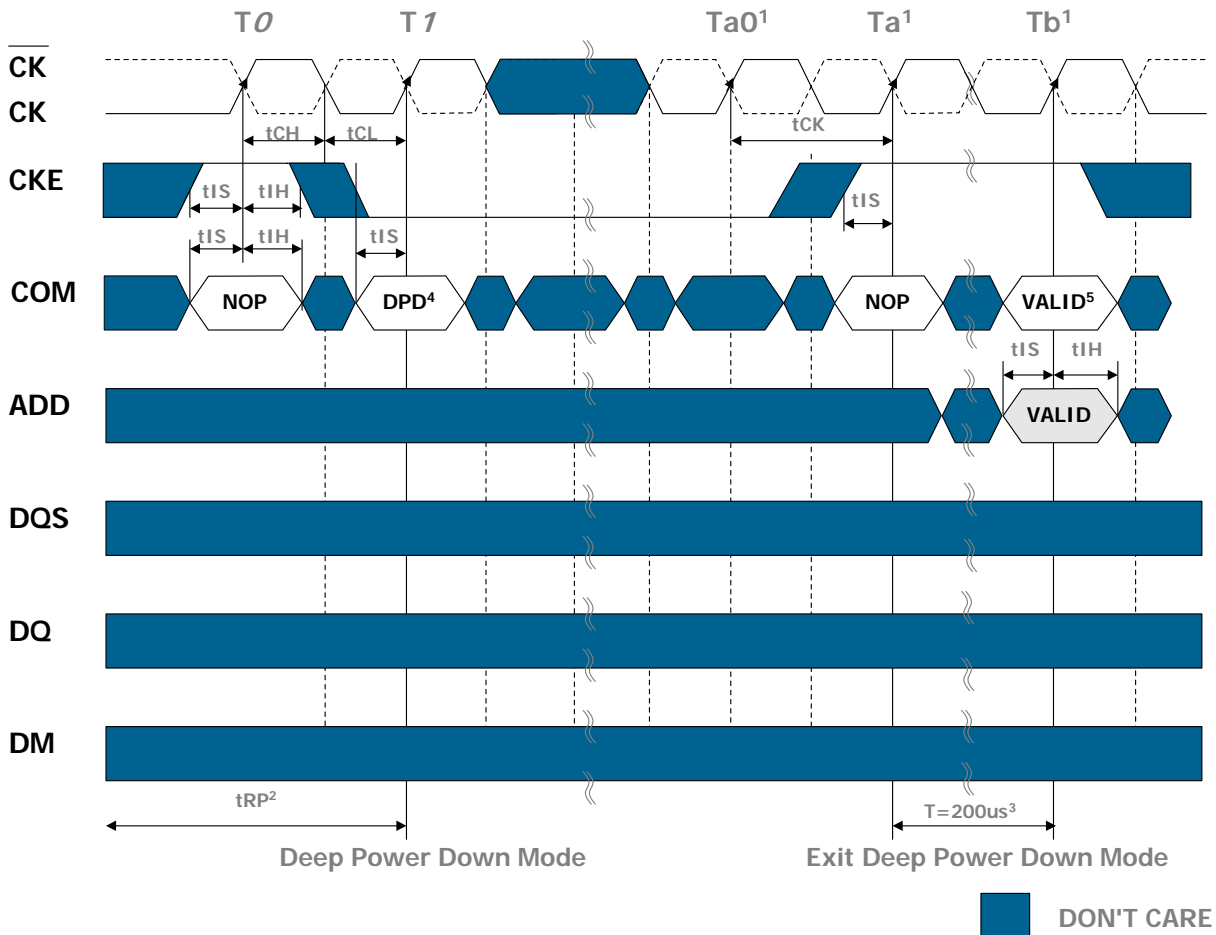

**Figure 5. Mobile DDR SDRAM Deep Power-Down Entry and Exit**

Note

1. Clock must be stable before exiting deep power down mode. That is, the clock must be cycling within specifications by Ta0.
2. Device must be in the all banks idle state prior to entering Deep Power Down mode.
3. 200us is required before any command can be applied upon exiting DPD.
4. DPD = Deep Power Down command.
5. Upon exiting Deep Power Down a precharge all command must be issued followed by two auto refresh commands and a load mode register sequence.

## Mobile DDR SDRAM Initialization and Entry and Exit Deep Power Down

### Initializing the Mobile DDR SDRAM

To ensure device functionality, there is a predefined sequence that must occur at device power up or if there is any interruption of device power.

- Steps follow:

- Step 1: Provide power, the device core power (VDD) and the device I/O power (VDDQ) must be brought up simultaneously to prevent device latch-up. Although not required, it is recommended that VDD and VDDQ are from the same power source. Also assert and hold CLOCK ENABLE (CKE) to a LVCMOS logic high level.
- Step 2: Once the system has established consistent device power and CKE is driven high, it is safe to apply stable clock.
- Step 3: There must be at least 200us of valid clocks before any command may be given to the DRAM. During this time NOP or DESELECT commands must be issued on the command bus.
- Step 4: Issue a PRECHARGE ALL command.
- Step 5: Provide NOPs or DESELECT commands for at least tRP time.
- Step 6: Issue an AUTO REFRESH command followed by NOPs or DESELECT command for at least tRFC time. Issue the second AUTO REFRESH command followed by NOPs or DESELECT command for at least tRFC time. Note as part of the initialization sequence there must be two auto refresh commands issued. The typical flow is to issue them at Step 6, but they may also be issued between steps 10 and 11.
- Step 7: Using the LMR command, load the base mode register. Set the desired operating modes.
- Step 8: Provide NOPs or DESELECT commands for at least tMRD time.
- Step 9: Using the LMR command, program the extended mode register for the desired operating modes. Note the order of the base and extended mode register programming is not important.
- Step 10: Provide NOP or DESELECT commands for at least tMRD time.
- Step 11: The DRAM has been properly initialized and is ready for any valid command.

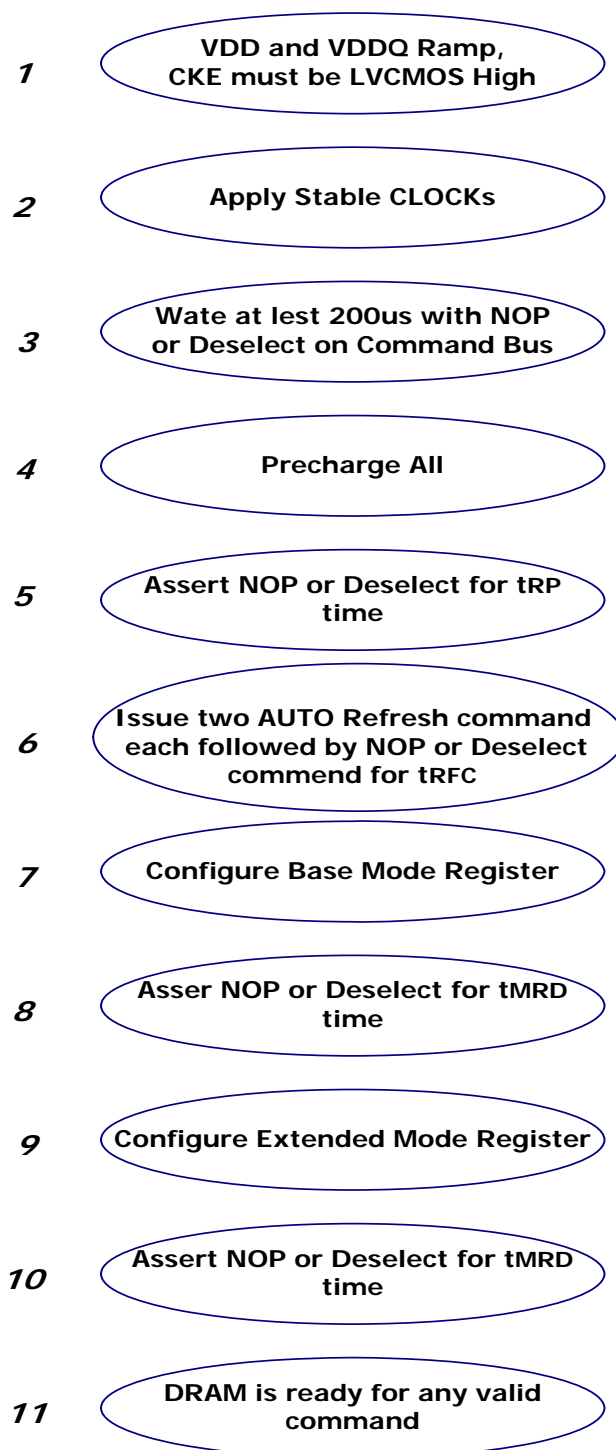

Figure 6. The Steps of Initializing (Mobile DDR SDRAM)

