

# Fibre Channel Dual Transformers

- Compliant with ANSI X3T11, Fibre Channel, FC-PH-3 for 1/4 & full speed applications, SMPTE
- Industrial temperature range -40 to +85° C
- For use with 150 ohm Twinax cable
- Designed to withstand infrared and vapor phase soldering
- Pick and place compatible
- Weight -- 1.0 grams

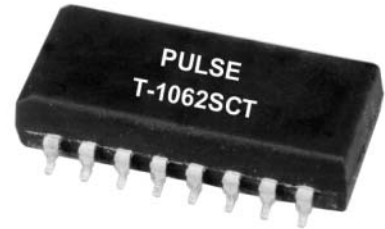

## ELECTRICAL CHARACTERISTICS; OPERATING TEMPERATURE -40 TO +85° C

Part No.	Turns Ratio ±5.0%	Primary Inductance OCL (µH, Min)	RiseTime (pS Max.) @ 20-80%	DC Resistance (W Max)	Hi-pot (Vrms Min)	Insertion Loss (Max)	Application Nominal Bit Rate (Mbaud)
T-330SCT	1CT:1CT	26.00 (@1.0 VRms,100KHz)	350.00	0.19	1,500	-1.50 dB (15 - 165 MHz)	265.625 (Quarter Speed)
T-1062SCT	1CT:1CT	3.75 (@10 mVRms,100KHz)	280.00	0.15	1,500	-2.00 dB (100 - 625 MHz)	1062.50 (Full Speed)
T-1250SCT	1CT:1CT	3.75	280.00	0.15	1,500	-2.00 dB	1250.00
T-1485SCT	1CT:1CT	3.75	280.00	0.15	1,500	-2.50 dB	1485.00 SMPTE

## MECHANICAL OUTLINE

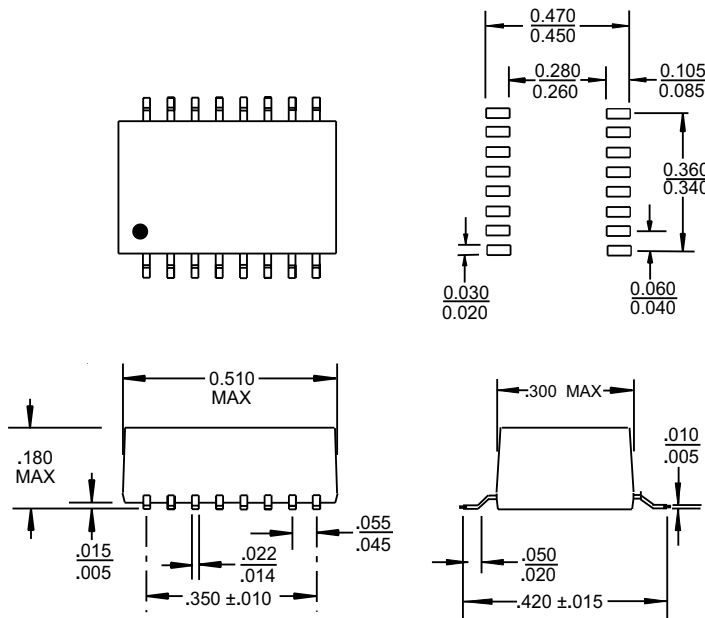

## SCHEMATIC

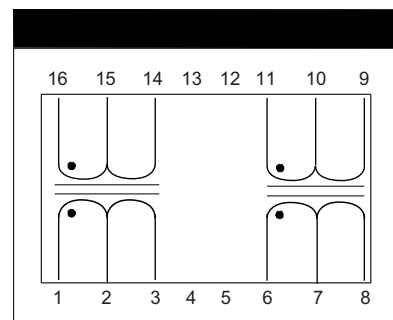



## APPLICATION

Pulse Specialty Components has designed Fibre Channel dual transformers specifically for point to point coupling to 150 ohm twinax cable. The isolation transformers protect the station from static charges that may develop on the cable and prevents ground loop currents from being transferred between stations. The devices have also been designed to provide common mode rejection within the transmission band and thus reduce EMI. The

wide bandwidth of these devices minimizes data dependent jitter by providing fast signal rise times. Low-end bandwidth also minimizes base-line wander, another contributor to jitter.

The dual package allows connection of both the transmit and receive channel, as shown in the application circuit below. Surface-mount packaging also allows a cost-effective solution.

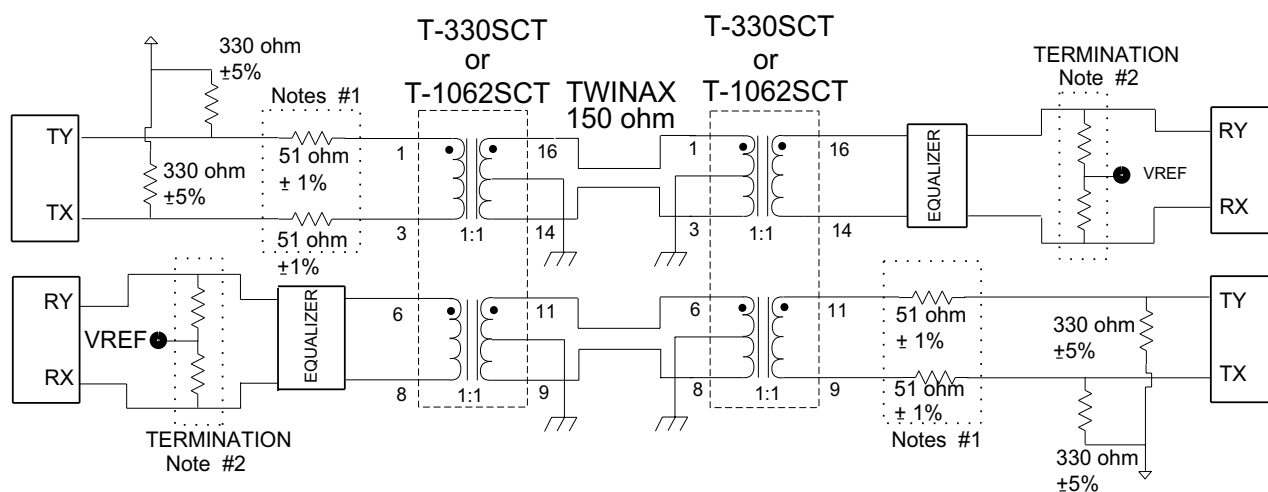

**Fig. 1: Typical Application Circuit**

Note 1 - The transformer, 51 ohm resistors, and the impedance of the driver are matched to achieve the best return loss (S11) for the transmitter of the 150 ohm system.

Note 2 - The total impedance of termination resistor network shall be 150 ohms.

Note 3 - When laying out PCB, transmission line methods must be utilized to maintain return loss and signal integrity. Transformer must be located within .50" of the DB9 connector.

Note 4 - It is recommended that the center tap (CT) of transformer(s), cable side, be connected to earth/chassis (cable shield) ground either directly or via a transient voltage suppressor (TVS) type component and earth/chassis ground should be "AC-coupled" to signal (digital) ground through a .027uF, 500V capacitor.