

MC68181*Product Preview***MC68181 ROAMING FLEX™ chip IC**

Roaming FLEX™ protocol is a multi-channel, multi-speed, high-performance protocol adopted by leading service providers worldwide as a de facto roaming paging standard. Roaming FLEX protocol gives service providers the increased capacity, added reliability, and enhanced pager battery performance needed today, coupled with the ability to control a PLL synthesized receiver to receive paging messages from a list of paging channels. It also provides an upward migration path to the service provider that is completely transparent to the end user.

The MC68181 Roaming FLEX chip IC is part of a total solution available from Motorola for providing Roaming FLEX capabilities in a low-power, low-cost system. The Roaming FLEX chip simplifies implementation of a Roaming FLEX paging device by interfacing with many standard paging receivers, and host microcontroller/microprocessors. The primary function of the Roaming FLEX chip is to process information received and demodulated from a radio paging channel, select messages addressed to the paging device, and communicate the message information to the host. The host interprets the message information in an appropriate manner (numeric, alphanumeric, binary, etc.) and handles all the I/O activity. The Roaming FLEX chip IC also operates the paging receiver in an efficient power consumption mode and enables the host to operate in a low power mode when message information for the paging device is not being received.

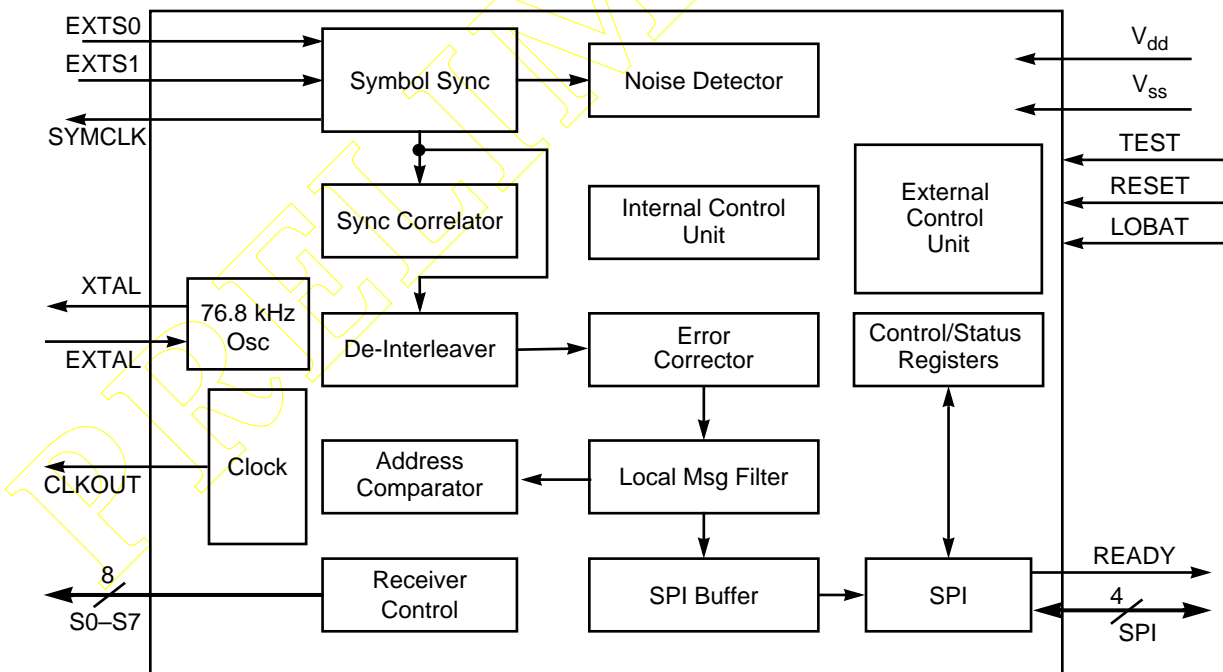

AA0813

Figure 1 Roaming FLEX chip IC Functional Block Diagram

This document contains information on a product under development. Motorola reserves the right to change or discontinue this product without notice.

FLEX chip FEATURES

- Roaming FLEX paging protocol signal processor
- Sixteen programmable user address words
- Sixteen fixed temporary addresses
- Sixteen operator messaging addresses
- 1600, 3200, and 6400 bits per second (bps) decoding
- Any-phase or single-phase decoding
- Uses standard Serial Peripheral Interface (SPI) in Slave mode
- Wide operating voltage range from 3.3 V down to 1.8 V
- Allows low current Stop mode operation of host processor
- Highly programmable receiver control
- Real time clock time base
- FLEX fragmentation, and group messaging support
- Real time clock over-the-air update support
- Compatible with synthesized receivers
- SSID and NID Roaming support
- Low battery indication (external detector)
- 32-pin Thin Quad Flat Pack (TQFP) package
- Backward compatible with standard FLEX chip Signal Processor MC68175
- Operating temperature range 0° to +70°C (32° to 158°F)

FLEX chip SYSTEM DESIGN

The Roaming FLEX™ chip IC connects to a receiver capable of converting a 4-level audio signal into a 2-bit digital signal (see **Figure 2**). The FLEX chip IC has eight receiver control lines used for tuning, warming up, and shutting down a receiver in stages. Dual bandwidth control signals for two post-detection filter bandwidths are used for receiving the two FLEX symbol rates. The FLEX chip interfaces to a back-end host MCU through a standard SPI, and provides a 38.4 kHz clock output capable of driving other devices. It has a 1 minute timer that offers low power support for time of day function on the host, and the ability to detect a low battery signal during the receiver control sequences.

All data communicated between the FLEX chip IC and the host MCU is transmitted on the SPI in 32-bit packets. Each packet consists of an 8-bit ID followed by 24 bits of information. The FLEX chip IC uses the SPI bus in Full Duplex mode, so whenever a packet communication occurs, the data in both directions is valid packet data.

PRODUCT DOCUMENTATION

The manual listed in **Table 1** is required for a complete description of the MC68181 and is necessary to design properly with the part. Documentation is available from a local Motorola distributor, a Motorola semiconductor sales office, a Motorola Literature Distribution Center, or through the Motorola DSP home page on the Internet.

Table 1 Additional Documentation

Document Name	Description	Order Number
MC68181 Technical Data	MC68181 features list and physical, electrical, timing, and package specifications	MC68181/D

FLEX, FLEXstack, and Mfax are trademarks of Motorola, Inc.



Motorola reserves the right to make changes without further notice to any products herein. Motorola makes no warranty, representation or guarantee regarding the suitability of its products for any particular purpose, nor does Motorola assume any liability arising out of the application or use of any product or circuit, and specifically disclaims any and all liability, including without limitation consequential or incidental damages. "Typical" parameters which may be provided in Motorola data sheets and/or specifications can and do vary in different applications and actual performance may vary over time. All operating parameters, including "Typicals" must be validated for each customer application by customer's technical experts. Motorola does not convey any license under its patent rights nor the rights of others. Motorola products are not designed, intended, or authorized for use as components in systems intended for surgical implant into the body, or other applications intended to support life, or for any other application in which the failure of the Motorola product could create a situation where personal injury or death may occur. Should Buyer purchase or use Motorola products for any such unintended or unauthorized application, Buyer shall indemnify and hold Motorola and its officers, employees, subsidiaries, affiliates, and distributors harmless against all claims, costs, damages, and expenses, and reasonable attorney fees arising out of, directly or indirectly, any claim of personal injury or death associated with such unintended or unauthorized use, even if such claim alleges that Motorola was negligent regarding the design or manufacture of the part. Motorola and  are registered trademarks of Motorola, Inc. Motorola, Inc. is an Equal Opportunity/Affirmative Action Employer.

How to reach us:

USA/Europe/Locations Not Listed:

Motorola Literature Distribution
P.O. Box 5405
Denver, Colorado 80217
1 (800) 441-2447
1 (303) 675-2140

Asia/Pacific:

Motorola Semiconductors H.K. Ltd.
8B Tai Ping Industrial Park
51 Ting Kok Road
Tai Po, N.T., Hong Kong
852-26629298

Japan:

Nippon Motorola Ltd
SPD, Strategic Planning Office
4-32-1, Nishi-Gotanda
Shinagawa-ku, Tokyo 141, Japan
81-3-5487-8488

Mfax™:

RMFAX0@email.sps.mot.com
TOUCHTONE (602) 244-6609
USA and Canada ONLY:
1 (800) 774-1848

Technical Resource Center:

1 (800) 521-6274

DSP Helpline

dsphelp@dsp.sps.mot.com

Internet:

<http://www.motorola.com/sps>



MOTOROLA