

# Subscriber Line Interface Circuit (SLIC)

## Key Features

- On-chip ringing generation
  - Balanced, up to 81 V<sub>Peak</sub>
  - Any waveform
  - 5REN ringing load
  - Automatic gain control of ring signal (AGC-R)
  - Short circuit safe
- Low on-hook power consumption in Active State (65 mW @ V<sub>Bat</sub> = -80 V)
- Automatic current controlled battery switching between on-hook battery (V<sub>Bat</sub>) and talk battery (V<sub>TBat</sub>)
- Pulse metering and on-hook transmission
- UL-1950 and MTU compliant on-hook line voltage
- 3.3 V compatible logic interface
- Silent or fast polarity reversal
- Programmable Ring-Trip current

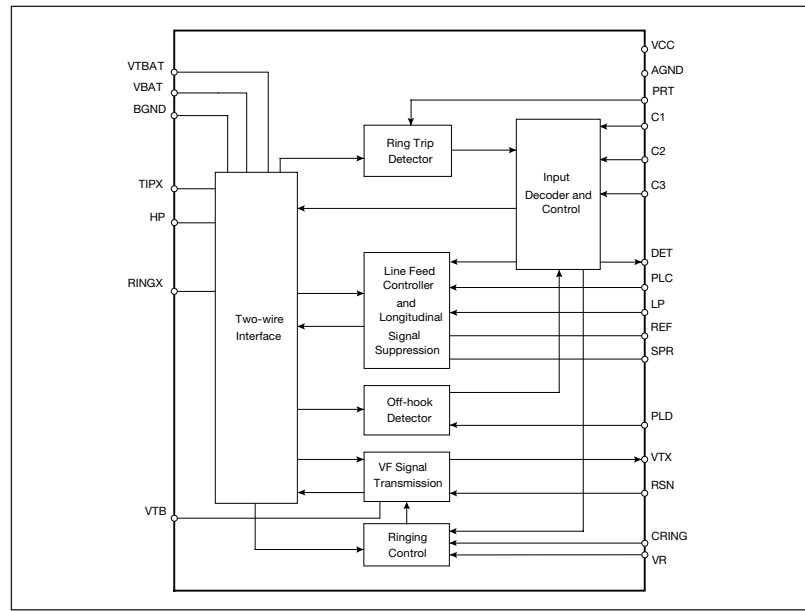

Figure 1. Block diagram.

## Description

The ringing FlexiSLIC™ PBL 387 74/1 Subscriber Line Interface Circuit (SLIC) is a 90 V bipolar integrated circuit for use in short loop applications. The PBL 387 74/1 SLIC has been optimized for low power consumption, low total line interface cost and for a high degree of flexibility in various applications.

The PBL 387 74/1 SLIC supplies a balanced, sinewave or trapezoidal ringing signal of up to 81 V<sub>Peak</sub> (85 V DC supply) to the subscriber line across a load of up to 5REN. The PBL 387 74/1 supplies programmable constant current to the subscriber loop, sourced from the talk battery. The On-Hook line voltage of 43 V to 56 V is derived from the battery. All battery switching is internal to the device and is automatic. To further reduce power consumption the automatic gain control for the ring signal (AGC-R) keeps the level always adjusted to the maximum, that can be sourced from the available battery.

The SLIC incorporates loop current, ground key and ring-trip detection functions. The PBL 387 74/1 is compatible with loop start and ground start signaling. Two- to four-wire and four- to two-wire voice frequency (vf) signal conversion is accomplished by the SLIC in conjunction with a standard codec. The line terminating impedance and balance impedance is programmable and may be complex or real for worldwide compliance.

Longitudinal balance specifications and other device characteristics are in compliance with Telcordia (Bell-core) and ITU-T requirements.

Tip and ring voltages are UL-1950 compliant; i.e. no two-wire line voltage exceeds 56 V. The PBL 387 74/1 SLIC is packaged in a surface mount 28-pin SOIC package.

## Maximum Ratings

Parameter	Symbol	Min	Max	Unit
<b>Temperature, Humidity</b>				
Storage temperature range	$T_{Stg}$	-55	+150	°C
Operating temperature range	$T_{Amb}$	-40	+110	°C
Operating junction temperature range, Note 1	$T_J$	-40	+140	°C
<b>Power supply, <math>-40^{\circ}\text{C} \leq T_{Amb} \leq +85^{\circ}\text{C}</math></b>				
$V_{CC}$ with respect to AGND	$V_{CC}$	-0.4	6.5	V
$V_{TB}$ with respect to AGND	$V_{TB}$	$V_{Bat}$	0.4	V
$V_{TBat}$ with respect to A/BGND	$V_{TBat}$	$V_{Bat}$	0.4	V
$V_{Bat}$ with respect to BGND, continuous	$V_{Bat}$	-85	0.4	V
<b>Power dissipation</b>				
Continuous power dissipation at $T_{Amb} \leq +85^{\circ}\text{C}$	$P_D$		1.5	W
Peak power dissipation @ $T_{Amb} = +85^{\circ}\text{C}$ , $t < 100\text{ ms}$ , $t_{Rep} > 1\text{ sec.}$	$P_{PD}$		4	W
<b>Ground</b>				
Voltage between AGND and BGND	$V_G$	-5	$V_{CC}$	V
<b>Digital inputs, outputs (C1, C2, C3, DET)</b>				
Input voltage	$V_{ID}$	-0.4	$V_{CC}$	V
Output voltage (DET not active)	$V_{OD}$	-0.4	$V_{CC}$	V
Output current (DET)	$I_{OD}$		30	mA
<b>Ring voltage, input (VR)</b>				
Input voltage	$V_R$	-1.1	$V_{CC}$	V
<b>TIPX and RINGX terminals, <math>-40^{\circ}\text{C} \leq T_{Amb} \leq +85^{\circ}\text{C}</math>, <math>V_{Bat} = -80\text{ V}</math></b>				
TIPX or RINGX current	$I_{TIPX}, I_{RINGX}$	-100	100	mA
TIPX or RINGX voltage, continuous (referenced to AGND)	$V_{TA}, V_{RA}$	$V_{Bat}$	2	V
TIPX or RINGX, pulse $< 10\text{ ms}$ , $t_{Rep} > 10\text{ s}$ , Note 2, Note 3	$V_{TA}, V_{RA}$	$V_{Bat} - 15$	5	V
TIPX or RINGX, pulse $< 1\text{ }\mu\text{s}$ , $t_{Rep} > 10\text{ s}$ , Note 2, Note 3	$V_{TA}, V_{RA}$	$V_{Bat} - 20$	10	V
TIP or RING, pulse $< 250\text{ ns}$ , $t_{Rep} > 10\text{ s}$ , Note 2, Note 3	$V_{TA}, V_{RA}$	$V_{Bat} - 25$	15	V

### Notes, Maximum Ratings

1. The circuit includes thermal protection. Operation above max. junction temperature may degrade device reliability.
2. With the diodes  $D_B$  and  $D_{TB}$  included, see figure 9.
3.  $R_{F1}$  and  $R_{F2} > 20\text{ }\Omega$  is required. Pulse is supplied to RING and TIP outside  $R_{F1}$  and  $R_{F2}$ .
4. The voltage of  $V_{TB}$  sets the maximum line length see figure 13. The diode  $D_{TB}$  is required see figure 9.

## Recommended Operating Condition

Parameter	Symbol	Min	Max	Unit
Ambient temperature	$T_{Amb}$	-40	+85	°C
$V_{CC}$ with respect to AGND	$V_{CC}$	4.75	5.25	V
$V_{TB}$ with respect to A/BGND, Note 4	$V_{TB}$	-32	-10	V
$V_{Bat}$ with respect to BGND	$V_{Bat}$	-80		V

### Electrical Characteristics

-40 °C ≤ T<sub>Amb</sub> ≤ +85 °C, V<sub>CC</sub> = +5 V ±5 %, V<sub>TBat</sub> = -32 V to -10 V, V<sub>Bat</sub> = -80 V, V<sub>R</sub> = 0.81 V<sub>pk</sub>, R<sub>LC</sub> = 18.7 kΩ, (I<sub>L</sub> = 26.8 mA), Z<sub>L</sub> = 600 Ω, R<sub>LD</sub> = 49.9 kΩ, R<sub>F1</sub> = R<sub>F2</sub> = 0, R<sub>Ref</sub> = 15.0 kΩ, R<sub>RT</sub> = 66.5 kΩ, C<sub>HP</sub> = 33 nF, C<sub>LP</sub> = 0.47 μF, R<sub>T</sub> = 120 kΩ, R<sub>RX</sub> = 120 kΩ, R<sub>VR</sub> = 200 kΩ, C<sub>VR</sub> = 0.47 μF.

Current definition: current is positive if flowing into a pin unless stated otherwise. Active state includes active normal and active reverse states unless otherwise specified.

Parameter	Ref fig	Conditions	Min	Typ	Max	Unit	
<b>Two-wire port</b>							
Overload level, V <sub>TRO</sub>	2	Active state					
Off-Hook, I <sub>LDC</sub> ≥ 10 mA		1% THD, Note 1	1.0			V <sub>Peak</sub>	
On-Hook, I <sub>LDC</sub> ≤ 5 mA			1.0			V <sub>Peak</sub>	
Metering, I <sub>LDC</sub> ≥ 10 mA		Z <sub>LM</sub> = 200 Ω, f = 16 kHz		0.7		V <sub>Peak</sub>	
Input impedance, Z <sub>TRX</sub>		Note 2		Z <sub>T</sub> /200		Ω	
Longitudinal impedance, Z <sub>LOT</sub> , Z <sub>LOR</sub>		0 < f < 100 Hz		20	35	Ω/wire	
Longitudinal current limit, I <sub>LOT</sub> , I <sub>LOR</sub>		active state	28			mA <sub>rms</sub> /wire	
Longitudinal to metallic balance, B <sub>LM</sub>		IEEE standard 455-1985, Z <sub>TRX</sub> = 736 Ω					
		0.2 kHz < f < 1.0 kHz	58	70		dB	
		1.0 kHz < f < 3.4 kHz	54	70		dB	
Longitudinal to metallic balance, B <sub>LME</sub>	3	active state					
		$B_{LME} = 20 \times \text{Log} \left  \frac{E_{LO}}{V_{TR}} \right $	0.2 kHz ≤ f ≤ 1.0 kHz	58	70		dB
		1.0 kHz < f < 3.4 kHz	54	70		dB	
Longitudinal to four-wire balance, B <sub>LFE</sub>	3	active state					
		$B_{LFE} = 20 \times \text{Log} \left  \frac{E_{LO}}{V_{TX}} \right $	0.2 kHz ≤ f ≤ 1.0 kHz	58	70		dB
		1.0 kHz < f < 3.4 kHz	54	70		dB	
Metallic to longitudinal balance, B <sub>MLE</sub>	4	active state					
		$B_{MLE} = 20 \times \text{Log} \left  \frac{V_{TR}}{V_{LO}} \right $ , E <sub>RX</sub> = 0	0.2 kHz < f < 3.4 kHz	40	58		dB

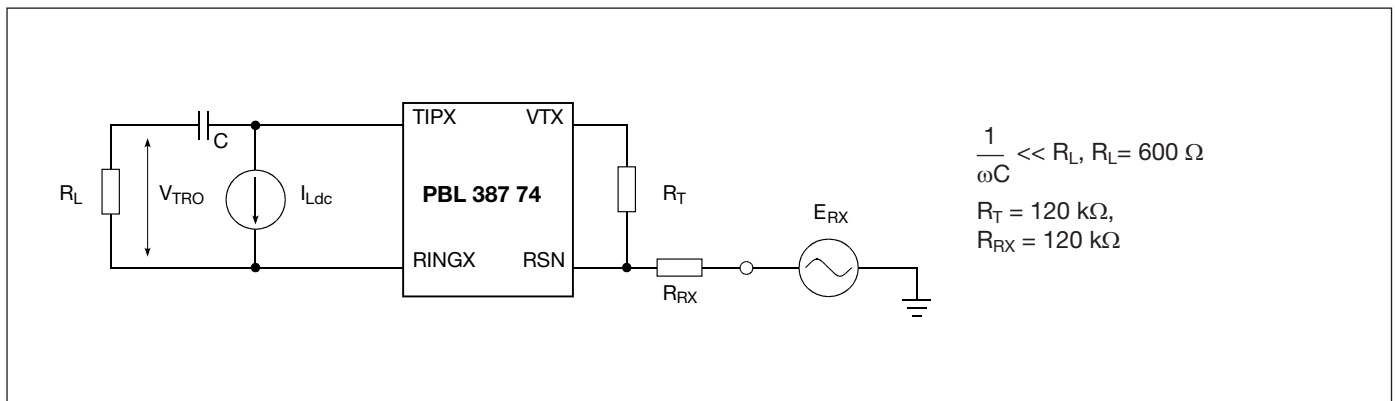

Figure 2. Overload level, V<sub>TRO</sub>, two-wire port.

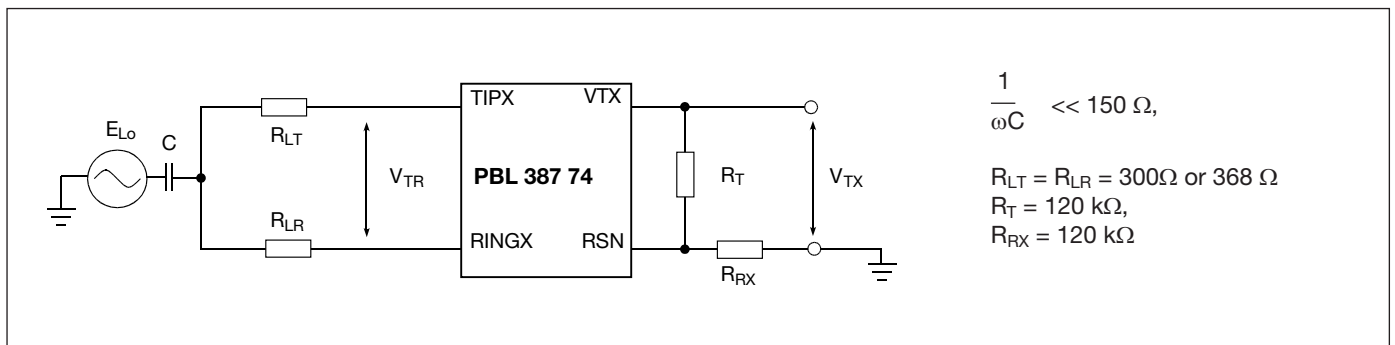

Figure 3. Longitudinal to metallic, B<sub>LME</sub>, and Longitudinal to four-wire, B<sub>LFE</sub>, balance.

Parameter	Ref fig	Conditions	Min	Typ	Max	Unit
Four-wire to longitudinal balance, $B_{FLE}$ $B_{FLE} = 20 \times \text{Log} \left  \frac{E_{RX}}{V_{Lo}} \right $	4	active state $0.2 \text{ kHz} < f < 3.4 \text{ kHz}$	40	58		dB
Two-wire return loss, $r$ $r = 20 \times \text{Log} \frac{ Z_{TRX} + Z_L }{ Z_{TRX} - Z_L }$		$0.2 \text{ kHz} < f < 0.5 \text{ kHz}$ $0.5 \text{ kHz} < f < 1.0 \text{ kHz}$ $1.0 \text{ kHz} < f < 3.4 \text{ kHz}$ , Note 3	25 27 23			dB dB dB
TIPX idle voltage, $V_{TI}$		active normal, $I_L = 0$		- 0.9		V
RINGX idle voltage, $V_{RI}$		active normal, $I_L = 0$		- 51		V
Open loop voltage, $ V_{TR \text{ Open}} $		active, $I_L = 0$	43	50	56	V
<b>Four-wire transmit port (VTX)</b>						
Overload level, $V_{TXO}$	5					
Off-hook, $I_L \geq 10\text{mA}$		Load impedance $> 20 \text{ k}\Omega$ ,	0.5			$V_{Peak}$
On-hook, $I_L \leq 5\text{mA}$		Load impedance $> 20 \text{ k}\Omega$ , 1% THD, Note 4	0.5			$V_{Peak}$
Output offset voltage, $\Delta V_{TX}$			-100		100	mV
Output impedance, $Z_{TX}$		$0.2 \text{ kHz} < f < 3.4 \text{ kHz}$		5	20	$\Omega$

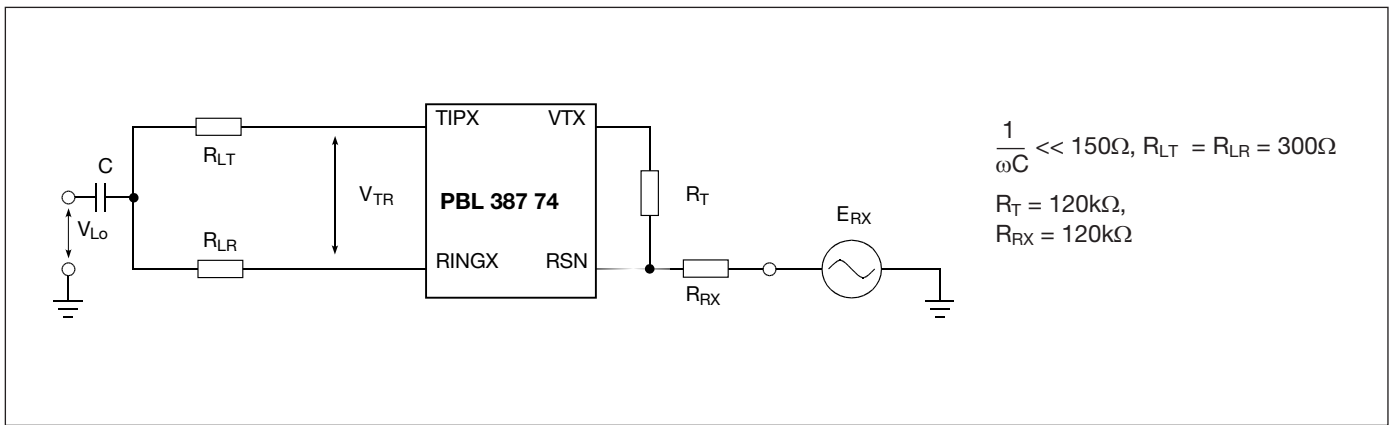

Figure 4. Metallic to longitudinal,  $B_{MLE}$  and four-wire to longitudinal balance,  $B_{FLE}$ .

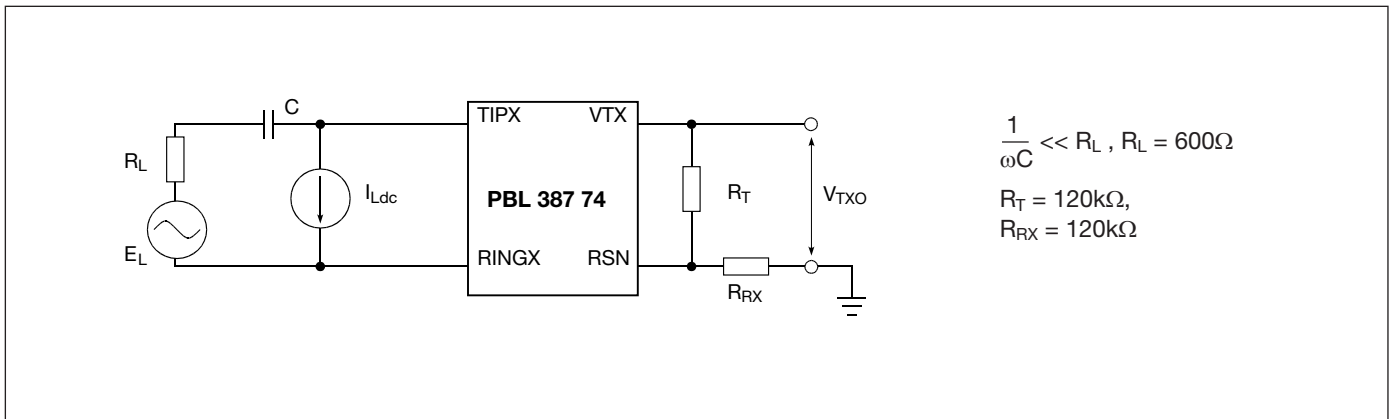

Figure 5. Overload level,  $V_{TXO}$ , four-wire transmit port.

Parameter	Ref fig	Conditions	Min	Typ	Max	Unit
<b>Four-wire receive port</b> (receive summing node = RSN)						
RSN dc offset voltage, $V_{RSNdc}$		$I_{RSN} = 0$ mA	-25		25	mV
RSN impedance		$0.2 \text{ kHz} < f < 3.4 \text{ kHz}$		10	50	$\Omega$
RSN current, $I_{RSN}$ , to metallic loop current, $I_L$ , gain, $\alpha_{RSN}$		$0.3 \text{ kHz} < f < 3.4 \text{ kHz}$		400		ratio
<b>Frequency response</b>						
Two-wire to four-wire, $g_{2-4}$	6	relative to 0 dBm, 1.0 kHz. $E_{RX} = 0$ V $0.3 \text{ kHz} < f < 3.4 \text{ kHz}$ $f = 8.0 \text{ kHz}, 12 \text{ kHz}, 16 \text{ kHz}$	-0.15 -0.5	-0.1	0.15 0.1	dB dB
Four-wire to two-wire, $g_{4-2}$	6	relative to 0 dBm, 1.0 kHz. $E_{LO} = 0$ V $0.3 \text{ kHz} < f < 3.4 \text{ kHz}$ $f = 8 \text{ kHz}, 12 \text{ kHz}, 16 \text{ kHz}$	-0.15 -1.0 -1.0	-0.2	0.15 0 0	dB dB dB
Four-wire to four-wire, $g_{4-4}$	6	relative to 0 dBm, 1.0 kHz. $E_{LO} = 0$ V $0.3 \text{ kHz} < f < 3.4 \text{ kHz}$	-0.15		0.15	dB
<b>Insertion loss</b>						
Two-wire to four-wire, $G_{2-4}$	6	0 dBm, 1.0 kHz, Note 5	-6.22	-6.02	-5.82	dB
$G_{2-4} = 20 \times \text{Log} \left  \frac{V_{TX}}{V_{TR}} \right $ , $E_{RX} = 0$						
Four-wire to two-wire, $G_{4-2}$	6	0 dBm, 1.0 kHz, Notes 5, 6	-0.2		0.2	dB
$G_{4-2} = 20 \times \text{Log} \left  \frac{V_{TR}}{E_{RX}} \right $ , $E_L = 0$						

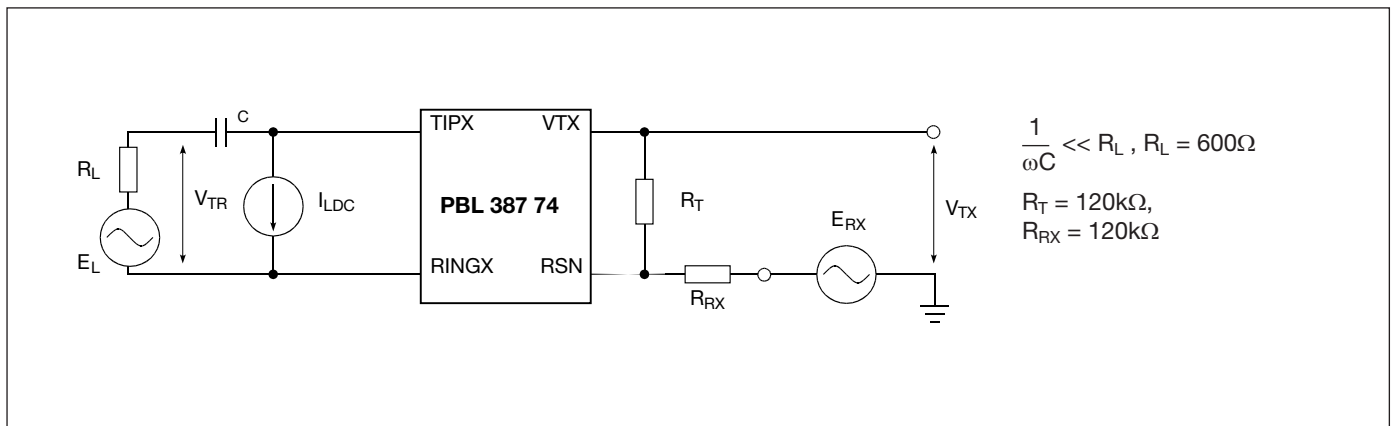

Figure 6. Frequency response, insertion loss, gain tracking.

Parameter	Ref fig	Conditions	Min	Typ	Max	Unit
<b>Gain tracking</b>						
Two-wire to four-wire $R_{LDC} \leq 2k\Omega$	6	Ref. -10 dBm, 1.0 kHz, Note 7 -40 dBm to +3 dBm -55 dBm to -40 dBm	-0.1 -0.2		0.1 0.2	dB dB
Four-wire to two-wire $R_{LDC} \leq 2k\Omega$	6	Ref. -10 dBm, 1.0 kHz, Note 7 -40 dBm to +3 dBm -55 dBm to -40 dBm	-0.1 -0.2		0.1 0.2	dB dB
<b>Noise</b>						
Idle channel noise at two-wire port (TIPX-RINGX)		C-message weighting Psophometrical weighting Note 8		7 -83	12 -78	dBmC dBmp
<b>Harmonic distortion</b>						
Two-wire to four-wire	6	0 dBm, 1.0 kHz test signal			-50	dB
Four-wire to two-wire		0.3 kHz < f < 3.4 kHz			-50	dB
<b>Battery feed characteristics</b>						
Constant loop current, $I_{LConst}$		$R_{LC} = \frac{500}{I_{LProg}} - \frac{10.4 \times \ln(32 \times I_{LProg})}{I_{LProg}}$ $18 < I_{LProg} < 30 \text{ mA}$	$0.94 \times I_{LProg}$	$I_{LProg}$	$1.06 \times I_{LProg}$	mA
<b>Tip open</b>						
Tip open state TIPX current, $I_{Leak}$	7	S = Closed; R = 7 k $\Omega$			-100	$\mu$ A
Tip open state RINGX current, $I_{LRTO}$	7	$R_{LRTO} = 0$ , $V_{BAT} = -80V$ $R_{LRTO} = 2.5 \text{ k}$ , $V_{BAT} = -80V$		$I_L$ 19		mA mA
Tip open state RINGX Voltage, $V_{RTO}$	7	$I_{LRTO} < 23 \text{ mA}$		-48.5		V
Tip voltage (ground start)	7	Active state, S = open Ring lead to Ground through 150 $\Omega$	-4	0		V
Tip voltage (ground start)	7	Active state, Tip lead to - 48 V through 7 k $\Omega$ (S = Closed) Ring lead to Ground through 150 $\Omega$	-6	0		V
Open circuit state loop current		$R_L = 0 \Omega$	-100	0	100	$\mu$ A
<b>Loop current detector</b>						
Programmable threshold, $I_{LTh}$		$I_{LTh} = \frac{500}{R_{LD}}$ , $I_{LTh} > 10 \text{ mA}$	$0.9 \times I_{LTh}$	$I_{LTh}$	$1.1 \times I_{LTh}$	mA

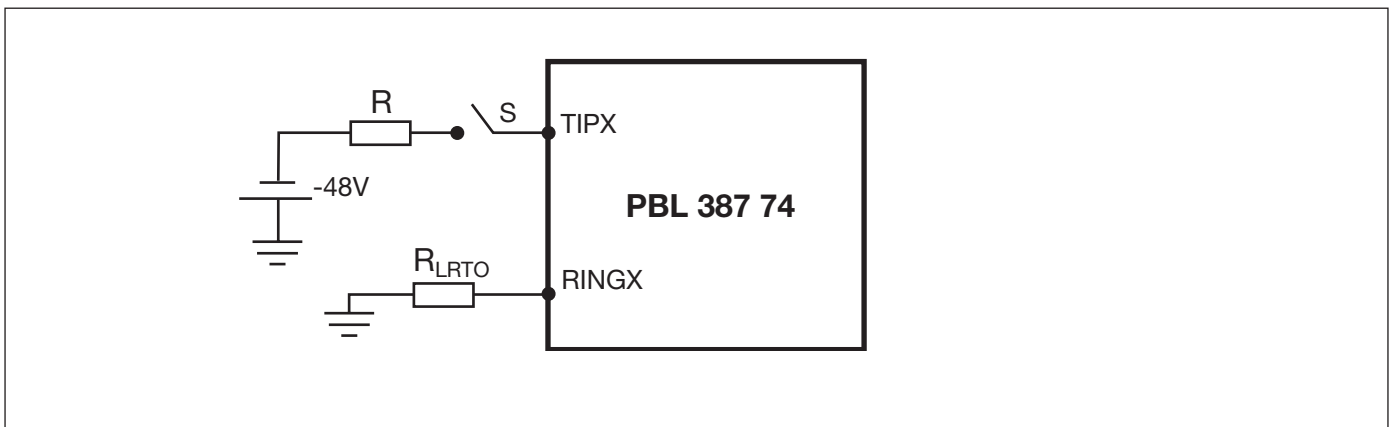

Figure 7. Tipx voltage.

Parameter	Ref fig	Conditions	Min	Typ	Max	Unit
<b>Ringing</b>						
$V_R$ input impedance			50			$M\Omega$
Input bias current $V_R$				7		nA
$V_R$ input voltage		Ref to AGND		0.81		$V_{Peak}$
Ring injection suppression		Active state, $R_L = 600 \Omega$		100		dB
Ringing gain		$V_R$ to two-wire, Note 9		94		ratio
Ringing voltage total distortion		$R_L = 1.4 \text{ k}\Omega - 40 \text{ k}\Omega$ , 25 Hz, Note 9		0.4	2	%
Voltage offset TIPX and RINGX		$ V_{Bat} /2 + 0.65$ , Note 9	-3	0	3	V
Common mode voltage TIPX and RINGX		$ V_{Bat} /2 + 0.65$	-0.4	0	0.4	V
<b>Ring-trip detector</b>						
Ring-trip current threshold, $I_{LRTh}$		Note 10	$0.92 \times I_{LRTh}$	$I_{LRTh}$	$1.08 \times I_{LRTh}$	mA
<b>Loop voltage measurement</b>						
Frequency		$f = \frac{10^6}{ V_{TR}  + 1}$		f		Hz
<b>Ground key detector and loop ground fault detector</b>						
Ground key detector threshold			9	15	19	mA
<b>Digital inputs (C1, C2, C3)</b>						
Input low voltage, $V_{IL}$			0		0.5	V
Input high voltage, $V_{IH}$			2.5		$V_{CC}$	V
Input low current, $ I_{IL} $		$V_{IL} = 0.5 \text{ V}$	-200			$\mu\text{A}$
Input high current, $ I_{IH} $		$V_{IH} = 2.5 \text{ V}$	-100			$\mu\text{A}$
<b>Detector output (DET)</b>						
Output low voltage, $V_{OL}$		$I_{OL} = 1 \text{ mA}$		0.1	0.6	V
Internal pull-up resistor to $V_{CC}$				10		$\text{k}\Omega$

Parameter	Ref fig	Conditions	Min	Typ	Max	Unit
<b>Power dissipation</b> ( $V_{\text{Bat}} = -80 \text{ V}$ , $V_{\text{TBat}} = -24 \text{ V}$ note 11)						
$P_1$		Open circuit state		16		mW
$P_2$		Active state Longitudinal current = 0 mA, $I_L = 0 \text{ mA}$		65		mW
$P_3$		Active state, $R_L = 300 \Omega$ (Off-hook)		0.50		W
$P_4$		Active state, $R_L = 600 \Omega$ (Off-hook)		0.29		W
$P_5$		Ringling state, $R_L = 7 \text{ k}\Omega$ (ac load $\approx 1 \text{ REN}$ ) Sine wave, 20 Hz, max. amplitude		0.36		W
<b>Power supply currents</b> ( $V_{\text{Bat}} = -80 \text{ V}$ )						
$V_{\text{CC}}$ current, $I_{\text{CC}}$		Open circuit state		1.4		mA
$V_{\text{TBat}}$ current, $I_{\text{TBat}}$		Open circuit state		0		mA
$V_{\text{TB}}$ current, $I_{\text{TB}}$		Open circuit state		-0.13		mA
$V_{\text{Bat}}$ current, $I_{\text{Bat}}$		Open circuit state		-0.07		mA
$V_{\text{CC}}$ current, $I_{\text{CC}}$		Active state, On-hook		2.4		mA
$V_{\text{TBat}}$ current, $I_{\text{TBat}}$		Active state, On-hook		0		mA
$V_{\text{TB}}$ current, $I_{\text{TB}}$		Active state, On-hook		-0.2		mA
$V_{\text{Bat}}$ current, $I_{\text{Bat}}$		Active state, On-hook		-0.6		mA
$V_{\text{CC}}$ current, $I_{\text{CC}}$		Ringling state, On-hook, No ring signal		7.1		mA
$V_{\text{TBat}}$ current, $I_{\text{TBat}}$		Ringling state, On-hook, No ring signal		0		mA
$V_{\text{TB}}$ current, $I_{\text{TB}}$		Ringling state, On-hook, No ring signal		-1		mA
$V_{\text{Bat}}$ current, $I_{\text{Bat}}$		Ringling state, On-hook, No ring signal		-2.7		mA
<b>Power supply rejection ratios</b>						
$V_{\text{CC}}$ to 2-wire port		Active State $f = 1 \text{ kHz}$ , $V_n = 100 \text{ mV}$	30	45		dB
$V_{\text{CC}}$ to 4-wire port		Active State $f = 1 \text{ kHz}$ , $V_n = 100 \text{ mV}$	36	51		dB
$V_{\text{TB}}$ to 2-wire port		Active State $f = 1 \text{ kHz}$ , $V_n = 100 \text{ mV}$	28.5	60		dB
$V_{\text{TB}}$ to 4-wire port		Active State $f = 1 \text{ kHz}$ , $V_n = 100 \text{ mV}$	34.5	66		dB
$V_{\text{Bat}}$ to 2-wire port		Active State $f = 1 \text{ kHz}$ , $V_n = 100 \text{ mV}$	40	60		dB
$V_{\text{Bat}}$ to 4-wire port		Active State $f = 1 \text{ kHz}$ , $V_n = 100 \text{ mV}$	46	66		dB
<b>Temperature guard</b>						
Junction threshold temperature, $T_{\text{JG}}$				155		$^{\circ}\text{C}$
<b>Thermal Resistance</b>						
Junction to pin, $\Theta_{\text{JP}}$				22		$^{\circ}\text{C}/\text{W}$
Junction to ambient, $\Theta_{\text{JA}}$				41.6		$^{\circ}\text{C}/\text{W}$

## Notes, Electrical characteristics

- The overload level is automatically expanded to needed signal level, maximum  $1.7 V_{Peak}$  when the signal level is  $> 1.0 V_{Peak}$ , and is specified at the two-wire port with the signal source at the four-wire receive port. For more information see section Adaptive overhead voltage.
- The two-wire impedance is programmable by selection of external component values according to:  

$$Z_{TRX} = Z_T / (|G_{2-4S} \times \alpha_{RSN}|)$$
 where:  
 $Z_{TRX}$  = impedance between the TIPX and RINGX terminals  
 $Z_T$  = programming network between the VTX and RSN terminals  
 $G_{2-4S}$  = transmit gain, nominally = 0.5  
 $\alpha_{RSN}$  = receive current gain, nominally 400 (current defined as positive flowing into the receive summing node, RSN, and when flowing from ring to tip). See section Transmission.
- Higher return loss values can be achieved by adding a reactive component to  $Z_T$ , the two-wire terminating impedance programming resistances, e.g. by dividing  $Z_T$  into two equal halves and connecting capacitors from the common points to ground.
- The overload level is automatically expanded as needed up to  $1.25 V_{Peak}$  (using the AOV function) when the signal level  $> 0.5 V_{Peak}$  and is specified at the four-wire transmit port, ( $V_{TX}$ ) with the signal source at the two-wire port. Note that the gain from the two-wire port to the four-wire transmit port is  $G_{2-4S} = 0.5$ .
- Secondary protection resistors  $R_{F1}$  and  $R_{F2}$  impact the insertion loss (refer to section Transmission). The specified insertion loss is for  $R_{F1} = R_{F2} = 40\Omega$ .
- The specified insertion loss tolerance does not include errors caused by external components.
- The level is specified at the four-wire receive port ( $E_{RX}$ , figure 6) and referenced to a  $600\Omega$  impedance level.
- The two-wire idle noise is specified with the four-wire receive port grounded ( $E_{RX} = 0$ , figure 6). The four-wire idle noise at VTX is the two-wire value reduced by 6 dB and is specified with the two-wire port terminated in  $600\Omega$  ( $R_L$ ). The VTX noise specification is referenced to a  $600\Omega$  impedance level.
- PBL 387 74/1 contains an Automatic Gain Control Ringing (AGC-R) unit. This unit controls the Gain in the ringing loop to keep an undistorted ringing signal due to variation in  $V_{BAT}$ ,  $V_R$  input signal amplitude and Voltage offset. For more information see section Ringing further on.
- See section Calculation of the ring-trip threshold for information about this.
- The  $V_{TBAT}$  voltage is optimized for  $R_L=600\Omega$ ,  $I_L = 26.8$  mA, no metering signal,  $R_F = 40$  and the current controlled battery switch. See section Optimizing  $V_{TB}$  for further information.

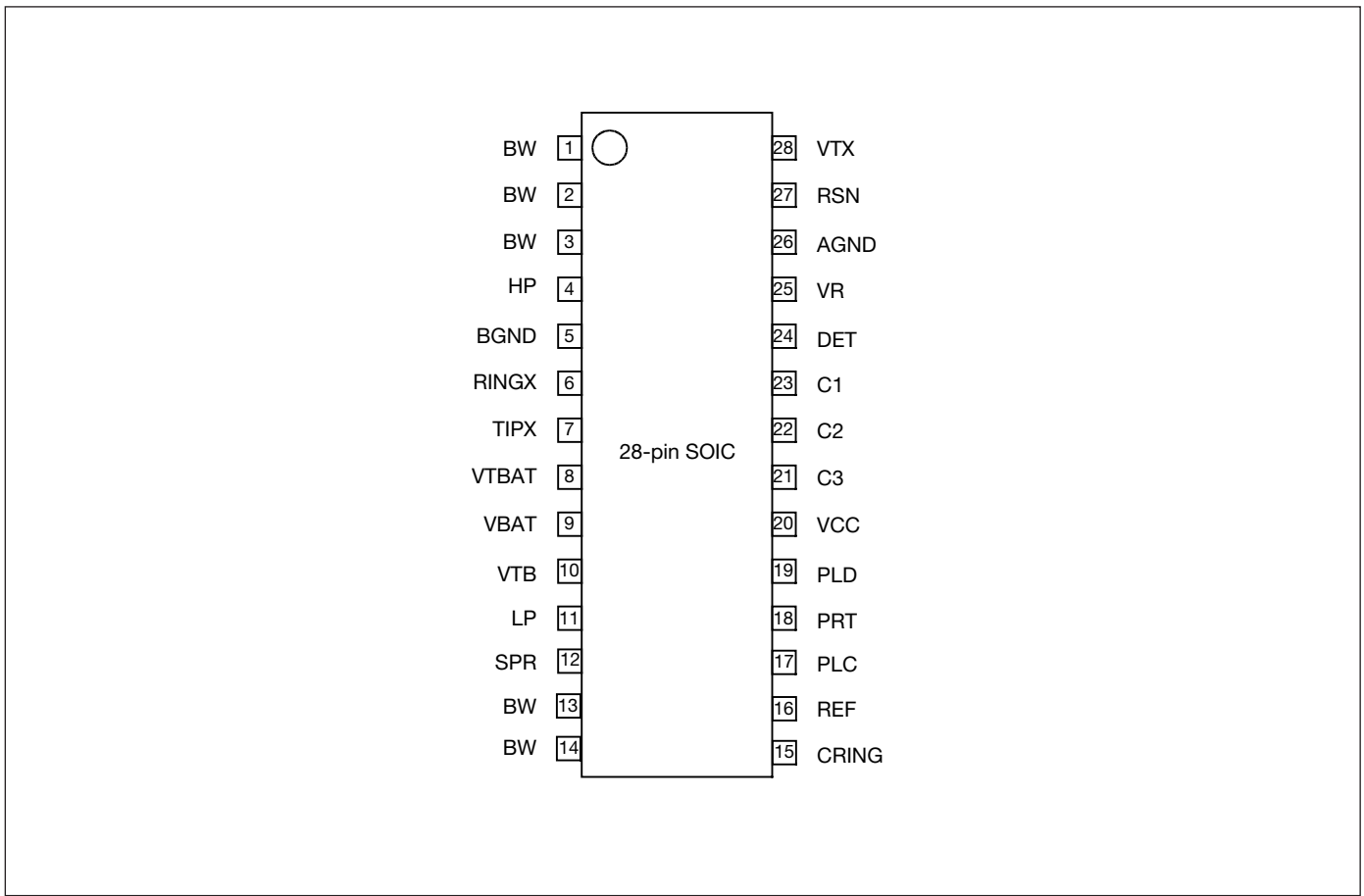

Figure 8. Pin configuration 28L-SOIC, top view.

## Pin Description

Pin	Symbol	Description
1	BW	<b>B</b> atwing (refer to Note, Pin Description)
2	BW	<b>B</b> atwing (refer to Note, Pin Description)
3	BW	<b>B</b> atwing (refer to Note, Pin Description)
4	HP	<b>H</b> igh <b>P</b> ass AC/DC separation capacitor $C_{HP}$ connects between this pin and TIPX.
5	BGND	<b>B</b> attery <b>G</b> round. Shall be tied together with AGND.
6	RINGX	The RINGX pin connects to the ring lead of the two-wire interface via over voltage protection components (and optional test access switch).
7	TIPX	The TIPX pin connects to the tip lead of the two-wire interface via over voltage protection components (and optional test access switch).
8	VTBAT	<b>T</b> alk <b>B</b> attery. The dc loop current is supplied to TIPX and RINGX from this battery voltage. Negative with respect to BGND.
9	VBAT	On-hook Ringing Battery supply voltage. Negative with respect to BGND.
10	VTB	Internal SLIC bias voltage. Connected to the talk battery supply. Refer to the application diagram in figure 9. May be connected to any voltage between -32 and -10 V.
11	LP	<b>L</b> ow <b>P</b> ass saturation guard filter capacitor $C_{LP}$ connects between this pin and VTBAT to filter out noise and improve PSRR.
12	SPR	<b>S</b> ilent <b>P</b> olarity <b>R</b> eversal. The polarity reversal time can be set with a capacitor connected between this pin and AGND.
13	BW	<b>B</b> atwing (refer to Note, Pin Description)
14	BW	<b>B</b> atwing (refer to Note, Pin Description)
15	CRING	The capacitor $C_{RING}$ connects between this pin and AGND. Required for the ring signal generation.
16	REF	A 15 k $\Omega$ resistor connected between this pin and AGND sets an internal SLIC reference current. The value must not be changed.
17	PLC	<b>P</b> rogrammable <b>L</b> ine <b>C</b> urrent. The constant current DC feed is programmed by a resistor connected from this pin to AGND.

18	PRT	Programmable Ring-trip Resistor RRT connected between this pin and AGND. Sets the ring-trip threshold. The capacitor C <sub>RT</sub> together with resistor R <sub>RT</sub> filters the ring-trip detector.
19	PLD	Programmable Loop Detector threshold. The loop detection threshold is programmed by a resistor, R <sub>LD</sub> , connected between this pin and AGND.
20	VCC	+5 V power supply.
21	C3	C1, C2, C3 are digital inputs, which control the SLIC operating states. Refer to table 1 for details.
22	C2	
23	C1	
24	DET	Detector output. Active low when indicating loop or ring-trip detection, active high when indicating ground key detection.
25	VR	Low voltage ringsignal input.
26	AGND	Analog Ground, shall be tied together with BGND.
27	RSN	Receive Summing Node. 400 times the current flowing out of this pin equals the metallic (transversal) current flowing from RINGX to TIPX. Programming networks for two-wire impedance and receive gain connect to the receive summing node.
28	VTX	Transmit vf output. The ac voltage difference between TIPX and RINGX, the ac metallic voltage, is reproduced at VTX with a gain of 0.5. The two-wire impedance programming network connects between VTX and RSN.

**Note:** A batwing is a package pin, which provides a low thermal resistance path to the silicon chip via the lead frame. By soldering the batwing pins to PCB copper foil the device can be efficiently cooled. Note that batwing pins are at the same voltage as the VBAT pin (substrate voltage).

## SLIC Operating States

State	C3	C2	C1	SLIC Operating State	Active detector (DET response)
0	0	0	0	TIPX & RINGX open circuit	No active detector (DET is set high)
1	0	0	1	Ringling	Ring-trip detector (DET active low)
2	0	1	0	Active	Loop current detector (DET active low)
3	0	1	1	Active	Loop voltage measurement (DET pulse train)
4	1	0	0	TIPX open circuit, RINGX active	Loop detector, RINGX current (DET active low)
5	1	0	1	Active	Ground key detector and loop ground fault detector (DET active high)
6	1	1	0	Active, reverse polarity	Loop current detector (DET active low)
7	1	1	1	Active, reverse polarity	Ground key detector and loop ground fault detector (DET active high)

Table 1. SLIC operating states.

## Functional Description and Applications Information

### Introduction

The Figure 9 diagram shows the PBL 387 74/1 in a typical application with a non-programmable, Combo I, codec. The PBL 387 74/1 can equally well be used with programmable codecs. This SLIC is suitable in short loop power sensitive application like, Cable modem, Voice over DSL, ISDN terminal adapter (NT1+), Voice over IP, Integrated Access Device (IAD), Residential Gateway or other short loop application. The component values chosen for the application diagram example yield a two-wire impedance of 600  $\Omega$ , resistive. The balance resistor is calculated for line impedance, ZL (compromise impedance), of 600  $\Omega$ , resistive. The two-wire to four-wire gain is set by  $R_{TX}$  and  $R_{FB}$  to produce the digital mW level at the PCM transmit bus.

RF1, RF2 and the clamp "OVP" make up the overvoltage protection network.

The ratio between  $R_{FB}$  and  $R_{TX}$  sets the transmit gain.

$C_{TC}$  and  $C_{RC}$  clamp fast transients that may bypass the OVP clamp and also filter high frequency interference (RFI filter).

$C_{HP}$  and  $C_{LP}$  are coupling capacitors within two SLIC feedback loops that control SLIC battery feed and SLIC voice frequency transmission.

$C_{TB}$ ,  $C_B$ ,  $C_{VCC}$  are power supply bypass capacitors.

$D_{TB}$  is a diode that is part of the battery switching function.

$D_B$  prevents reverse currents from the VB supply rail during application of negative over voltages.

$D_{BB}$	is normally reverse biased, but conducts supply VTB to the VBAT terminal in case the voltage $V_B$ would fail.
$R_T$	sets the two-wire impedance (note that $R_T$ may be replaced with a complex impedance, $Z_T$ , to implement complex terminating impedance).
$R_{RX}$	sets the receive gain.
$R_{LD}$	sets the loop current detector threshold.
$R_{LC}$	sets the constant dc loop current.
$R_{REF}$	sets a SLIC reference current (must be 15.0 k $\Omega$ , 1%, as specified).
$R_{RT}$	sets the ring trip loop current detector threshold.
$C_{RING}$	is used for the high voltage ringing signal AGC (automatic gain control) function.
$V_{TB}$	is the talk battery supply, i.e. the negative supply voltage that sources the loop current.
$V_B$	is the ringing battery, i.e. the negative supply voltage that is used to power the SLIC, while ringing the line. This battery is also used to provide on-hook voltage.

### Design supporting tools

The following supporting tools are available for the PBL 387 74/1:

- Test board, TB 215
- Pspice model PBL 387 74/1

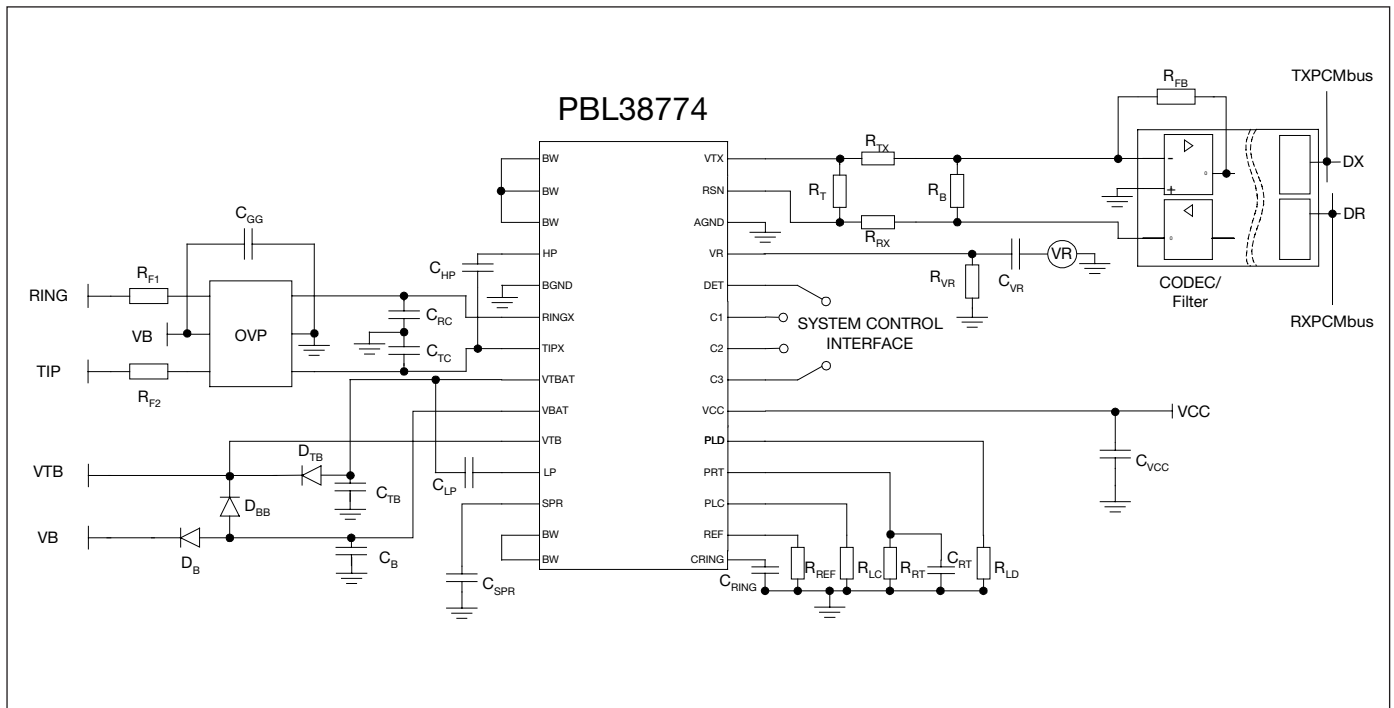

Figure 9. Single channel subscriber line interface with PBL 387 74/1 and Combo I type codec.

### PBL 387 74/1 components

#### RESISTORS :

(values according to IEC-63 E96 series)

R <sub>LD</sub>	= 49.9 kΩ	1%	1/10 W
R <sub>LC</sub>	= 18.7 kΩ	1%	1/10 W
R <sub>RT</sub>	= 61.9 kΩ	1%	1/10 W @ V <sub>BAT</sub> = 80 V
R <sub>REF</sub>	= 15 kΩ	1%	1/10 W
R <sub>T</sub>	= 105 kΩ	1%	1/10 W (for 600 Ω two-wire impedance with the R <sub>F1</sub> and R <sub>F2</sub> included.)
R <sub>RX</sub>	= 105 kΩ	1%	1/10 W (The gain is set to 1)
R <sub>VR</sub>	= 200 kΩ	1%	1/10 W
R <sub>TX</sub>	= 32.4 kΩ	1%	1/10 W
R <sub>B</sub>	= 57.6 kΩ	1%	1/10 W
R <sub>FB</sub>	= depending on codec		
R <sub>F1</sub> = R <sub>F2</sub>	= Line protection resistor, 40Ω 1% match, e.g. by Bourns TBD		

#### OPTIONAL CAPACITORS:

C <sub>TC</sub>	= 1.0 nF	100 V	20%
C <sub>RC</sub>	= 1.0 nF	100 V	20%
C <sub>SPR</sub>	= optional	10 V	20%

#### DIODES:

D<sub>B</sub> = D<sub>TB</sub> = D<sub>BB</sub> = TBD

#### OVP:

Secondary protection clamp (e.g. Bourns/Power Innovations TISP PBL3 or TISP 6NTP2A , which serves two lines). The ground terminals of the secondary protection should be connected to the common ground on the Printed Board Assembly with a track as short and wide as possible, preferably to a ground plane.

#### CAPACITORS:

(values according to IEC-63 E6 series)

C <sub>TB</sub>	= 150 nF	100 V	20%
C <sub>B</sub>	= 100 nF	100 V	20%
C <sub>VCC</sub>	= 100 nF	10 V	20%
C <sub>HP</sub>	= 33 nF	100 V	20%
C <sub>LP</sub>	= 470 nF	100 V	20%
C <sub>GG</sub>	= 220 nF	100 V	20%
C <sub>RING</sub>	= 470 nF	10 V	20%
C <sub>RT</sub>	= 10 nF	10 V	20%
C <sub>VR</sub>	= 470 nF	10 V	20%

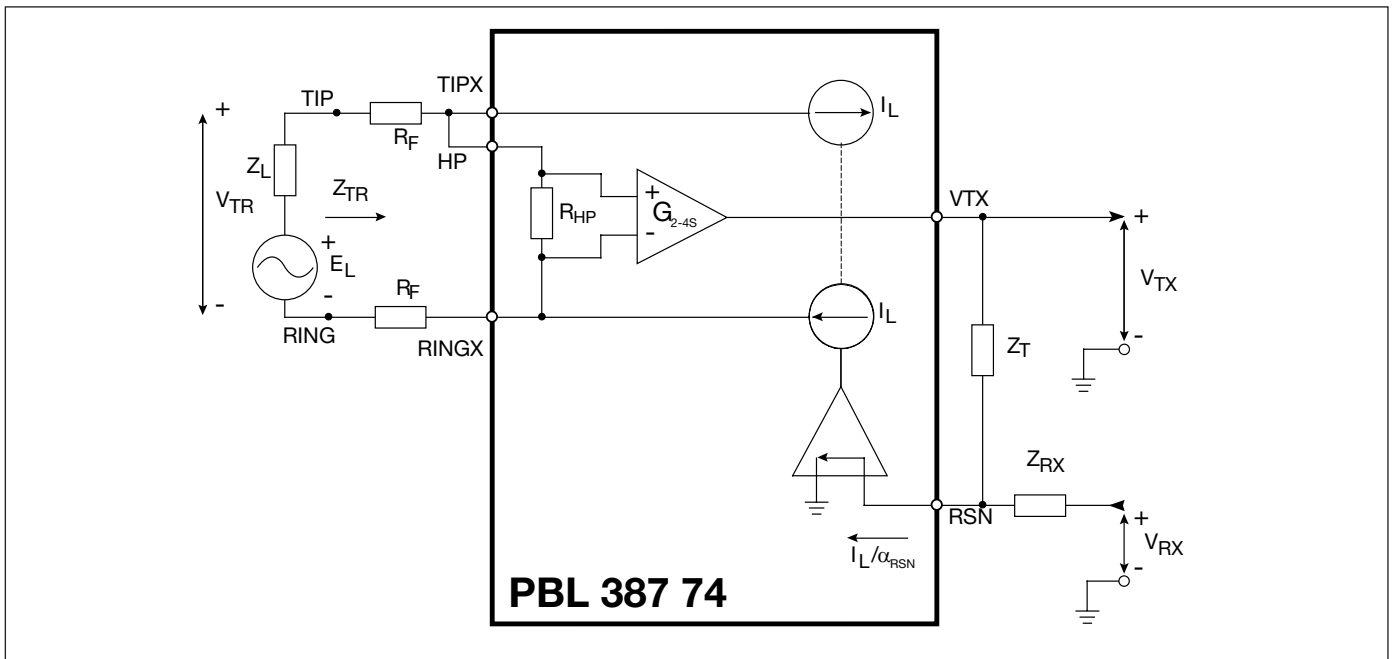

Figure 10. Simplified AC model of PBL 387 74/1.

## Transmission

### General

A simplified ac model of the transmission circuit is shown in figure 10. Circuit analysis yields:

$$V_{TR} = \frac{V_{TX}}{G_{2-4S}} + I_L \times 2R_F \quad (1)$$

$$\frac{I_L}{\alpha_{RSN}} = \frac{V_{TX}}{Z_T} + \frac{V_{RX}}{Z_{RX}} \quad (2)$$

$$V_{TR} = E_L - I_L \times Z_L \quad (3)$$

where:

- $V_{TX}$  is the ground referenced ac voltage at the  $V_{TX}$  terminal.
- $V_{TR}$  is the ac metallic voltage between tip and ring.
- $E_L$  is the line open circuit ac metallic voltage.
- $I_L$  is the ac metallic current.
- $R_F$  is a line over voltage protection resistor.
- $G_{2-4S}$  is the SLIC two-wire to four-wire gain (transmit direction) with a nominal value of 0.5.
- $Z_L$  is the total line impedance
- $Z_{RX}$  controls four- to two-wire gain.
- $Z_T$  determines the SLIC TIPX to RINGX ac impedance for signals at voice frequencies.
- $V_{RX}$  is the analog ground referenced receive signal.
- $\alpha_{RSN}$  is the receive summing node current to metallic loop current gain.  $\alpha_{RSN} = 400$
- $R_{HP}$  internal resistor, approx. 400 k $\Omega$

### Two-Wire Impedance

To calculate  $Z_{TR}$ , the impedance presented to the two-wire line by the SLIC including the line protection resistors  $R_F$ , let  $V_{RX} = 0$ .

From (1) and (2):

$$Z_{TR} = \frac{Z_T}{\alpha_{RSN} \times G_{2-4S}} + 2R_F \quad (4)$$

Thus with  $Z_{TR}$ ,  $G_{2-4S}$ ,  $\alpha_{RSN}$  and  $R_F$  known:

$$Z_T = \alpha_{RSN} \times G_{2-4S} \times (Z_{TR} - 2R_F) \quad (5)$$

### Two-Wire to Four-Wire Gain

From (1) and (2) with  $V_{RX} = 0$ :

$$G_{2-4} = \frac{V_{TX}}{V_{TR}} = \frac{Z_T/\alpha_{RSN}}{\frac{Z_T}{\alpha_{RSN} \times G_{2-4S}} + 2R_F} \quad (6)$$

### Four-Wire to Two-Wire Gain

From (1), (2) and (3) with  $E_L = 0$ :

$$G_{4-2} = \frac{V_{TR}}{V_{RX}} = -\frac{Z_T}{Z_{RX}} \times \frac{1}{G_{2-4S}} \times \frac{Z_L}{\frac{Z_T}{\alpha_{RSN} \times G_{2-4S}} + Z_L + 2R_F} \quad (7)$$

For applications where

$$\frac{Z_T}{\alpha_{RSN} \times G_{2-4S}} + 2R_F = Z_L$$

the expression for  $G_{4-2}$  simplifies to:

$$G_{4-2} = -\frac{Z_T}{Z_{RX}} \times \frac{1}{2 \times G_{2-4S}} \quad (8)$$

**Four-Wire to Four-Wire Gain**

From (1), (2) and (3) with  $E_L = 0$ :

$$G_{4-4} = \frac{V_{TX}}{V_{RX}} = - \frac{Z_T}{Z_{RX}} \times \frac{Z_L + 2R_F}{\frac{Z_T}{\alpha_{RSN} \times G_{2-4S}} + Z_L + 2R_F} \quad (9)$$

**Hybrid Function**

The PBL 387 74/1 SLIC may be used together with either software programmable or non-programmable codec/filters. When used together with programmable codec/filters the system controller permits adjustment of hybrid balance to accommodate different line impedances without change of hardware. In addition, the transmit and receive gains may be adjusted under software control. Please, refer to applicable programmable codec/filter data sheets for design information. The hybrid function can also be implemented utilizing the uncommitted amplifier in conventional non software programmable codec/filters. Please, refer to figure 11. Via impedance  $Z_B$  a current proportional to  $V_{RX}$  is injected into the summing node of the combination codec/filter amplifier. As can be seen from the expression for the four-wire to four-wire gain,  $G_{4-4}$ , a voltage proportional to  $V_{RX}$  is returned to  $V_{TX}$ . This voltage is converted by  $R_{TX}$  to a current flowing into the same summing node. These currents can be made to cancel by letting:

$$\frac{V_{TX}}{R_{TX}} = - \frac{V_{RX}}{Z_B} = 0 \quad (E_L = 0)$$

The four-wire to four-wire gain,  $G_{4-4}$ , includes the required phase shift and thus the balance network  $Z_B$  can be calculated from:

$$Z_B = -R_{TX} \times \frac{V_{RX}}{V_{TX}} = R_{TX} \times \frac{Z_{RX}}{Z_T} \times \frac{Z_T}{\alpha_{RSN} \times G_{2-4S}} + Z_L + 2R_F$$

When selecting the  $R_{TX}$  resistance value, make sure the load resistance on the VTX terminal is at least 20 kΩ, i.e.

$$\left| \frac{Z_T \times R_{TX}}{Z_T + R_{TX}} \right| = \geq 20 \text{ k} \Omega$$

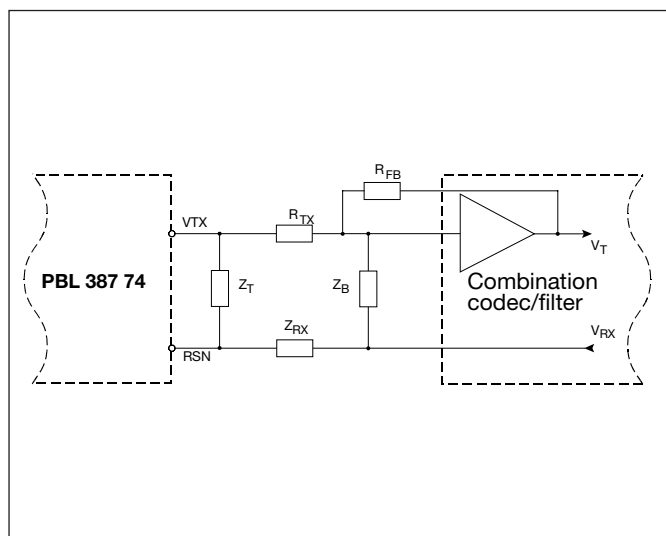

Figure 11. Hybrid function.

**Longitudinal impedance**

A feedback loop within the SLIC counteracts longitudinal voltages at the two-wire port by injecting longitudinal currents in opposing phase. Thus longitudinal disturbances will appear as longitudinal currents and the TIPX and RINGX terminals will experience very small longitudinal voltage excursions, leaving metallic voltages well within the SLIC common mode range.

The SLIC longitudinal impedance per wire,  $Z_{LoT}$  and  $Z_{LoR}$ , appears as typically 20 Ω to longitudinal disturbances. It should be noted that longitudinal currents may exceed the dc loop current without disturbing the vf transmission.

**Capacitors  $C_{TC}$  and  $C_{RC}$  (Optional)**

The primary function of the capacitors  $C_{TC}$  and  $C_{RC}$  is as a part of the overvoltage protection network. The overvoltage protection clamp may not respond quickly enough to very fast transients and therefore damaging voltages may reach the SLIC pins TIPX and RINGX.  $C_{TC}$  and  $C_{RC}$  will protect the SLIC by shunting such fast transients to ground.

$C_{TC}$  and  $C_{RC}$  may be utilized for RFI filtering when needed.  $C_{TC}$  and  $C_{RC}$  form RFI filters in conjunction with suitable series impedances (i.e. resistances, inductances). Resistors  $R_{F1}$  and  $R_{F2}$  may be sufficient, but series inductances can be added to form a second order filter. Current-compensated inductors (common mode chokes) are suitable since they impose little metallic impedance but high longitudinal impedance, therefore having minimum influence on two-wire transmission. Recommended values for  $C_{TC}$  and  $C_{RC}$  are 1 nF or less. Lower values implies less influence on the return loss and less degradation of the longitudinal balance caused by mismatching between  $C_{TC}$  and  $C_{RC}$ . On the other hand with lower values of  $C_{TC}$  and  $C_{RC}$  will decrease the attenuation of longitudinal induced radio frequencies. The influence of these capacitors on the two-wire terminating impedance must be considered when selecting a value for  $C_{TC} = C_{RC}$ .  $C_{TC}$  and  $C_{RC}$  contribute to a metallic impedance of  $1/(\pi \times f \times C_{TC}) = 1/(\pi \times f \times C_{RC})$ , a TIPX to ground impedance of  $1/(2 \times \pi \times f \times C_{TC})$  and a RINGX to ground impedance of  $1/(2 \times \pi \times f \times C_{RC})$ .

**Ac - dc separation capacitor,  $C_{HP}$**

The high pass filter capacitor connected between terminals HP and TIPX provides the separation of the ac and dc signals, such that only ac signals are forwarded to the VTXP and VTXM terminals.  $C_{HP}$  positions the low end frequency response break point of the ac feedback loop in the SLIC. The  $C_{HP}$  value of 33 nF will position the low end frequency response 3 dB break point of the ac loop at 12 Hz ( $f_{3dB}$ ) according to  $f_{3dB} = 1/(2 \times \pi \times R_{HP} \times C_{HP})$  where  $R_{HP} = 400 \text{ k} \Omega$ .

**Capacitor  $C_{LP}$**

The capacitor  $C_{LP}$ , which connects between the terminals LP and VTBAT, positions the high end frequency break point of the low pass filter in the dc feedback loop (battery feed controlling loop) of the SLIC. Both  $C_{LP}$  and  $C_{HP}$  influence the two-wire impedance at low frequencies (primarily below the vf band) by adding an impedance in parallel with the programmed two-wire impedance (set by  $R_{TM}$  and  $R_{TP}$  and/or

the Z-filter in the codec). The SLIC SPICE model includes the effects of  $C_{LP}$  and  $C_{HP}$  on the vf transmission. The  $C_{LP}$  value of 470 nF will position the high end frequency response 3 dB break point of the ac loop at 0.3 Hz ( $f_{3dB}$ ).

**Adaptive overhead voltage, AOV**

The Adaptive Overhead Voltage feature minimizes the SLIC power dissipation by permitting the TIPX and RINGX dc voltages to operate very close to the supply rails. When the SLIC detects a condition where the ac signal on TIPX/RINGX is approaching the supply rail and therefore would become distorted, the SLIC adjusts the overhead voltage, such that the TIPX/RINGX dc bias is moved away from the rails and thereby yielding enough peak signal swing for the ac signal. High level signal conditions such as when voice and metering signals are transmitted simultaneously are therefore automatically accommodated for the duration of the high level signal condition. This AOV system provides the designer with a flexible solution for different system requirements and possible future changes regarding voice, metering and other signal levels. There is no dc overhead level that must be set to a fixed value on account of worst case predicted peak ac signal value. Overhead voltage is defined as the voltage between TIPX and RINGX or RINGX and VTB (depending on selected state or used battery). The PBL387 74/1 will behave as a SLIC with fixed overhead voltage for signals in the 0-20 kHz range and with an amplitude less than  $1V_{Peak}$ . For signal amplitudes between  $1V_{Peak}$  and  $1.25 V_{Peak}$  the adaptive overhead function will expand the overhead voltage making it possible for the signal to propagate through the SLIC without distortion. The expansion of the overhead occurs instantaneously. When the signal amplitude decreases, the overhead returns to its initial value with a time constant of approximately one second. During operation the influence of the adaptive overhead function will not effect the SLIC performance in the constant

current region of operation. If, however, the SLIC is in the off-hook, constant voltage region of operation, then the influence of the adaptive headroom will be apparent as a slight decrease in line voltage (and hence line current) as the SLIC adjusts to accommodate the larger signal (e.g. voice + metering).

**Metering Applications**

Subscriber Pulse Metering (SPM), also known as Advice-of-Charge signaling (AOC), is used in several European countries to provide the subscriber with an accurate indication of the cost of a call in progress. Pulses of an out-of-speechband signal are sent at the same time as the speech signal down the telephone line, the rate of the pulses indicating the cost of the call - faster pulse rates indicate a more expensive call. An electronic meter at the subscriber counts the pulses as they arrive and indicates the call cost on a digital display. This meter is normally wired in parallel with the telephone circuit and also provides filtering of the signal so that the subscriber at the telephone does not hear it.

There are two frequencies used for SPM signaling: 12kHz and 16kHz. The frequency used depends on the national requirements. The frequency of the SPM signal must be quite accurate,  $\pm 0.5\%$  is typical. Furthermore the signal must be sinusoidal with  $<5\%$  total harmonic distortion. Pulse metering signals can be applied to the two-wire line via the PBL 387 74/1 SLIC by connecting the pulse-metering source through coupling capacitor ( $C_{TTX}$ ) and resistor ( $R_{TTX}$ ) to the RSN node. The capacitor in series isolates the RSN input from any dc voltage that may be superimposed on the metering signal. The signal level of metering has to be included when optimizing talk battery  $V_{TB}$ . It is possible to mix speech and metering up to  $1.7 V_{Peak}$  using the AOV function. The metering signal gain can be calculated from the equation:

$$G_{4-2TTX} = \frac{V_{TRTTX}}{V_{RTTX}} = - \frac{Z_T}{Z_{TTX}} \times \frac{1}{G_{2-4S}} \times \frac{Z_{LTTX}}{\alpha_{RSN} \times G_{2-4S} + Z_{LTTX} + 2R_F}$$

where

- $V_{TRTTX}$  is the desired metering voltage between the TIP and RING terminals
- $V_{RTTX}$  is the metering voltage injected via the resistor  $R_{TTX}$
- $Z_{LTTX}$  is the line impedance seen by the 12 or 16 kHz metering signal, typically 200  $\Omega$
- $G_{2-4S}$  is the transmit gain through the SLIC (0.5).

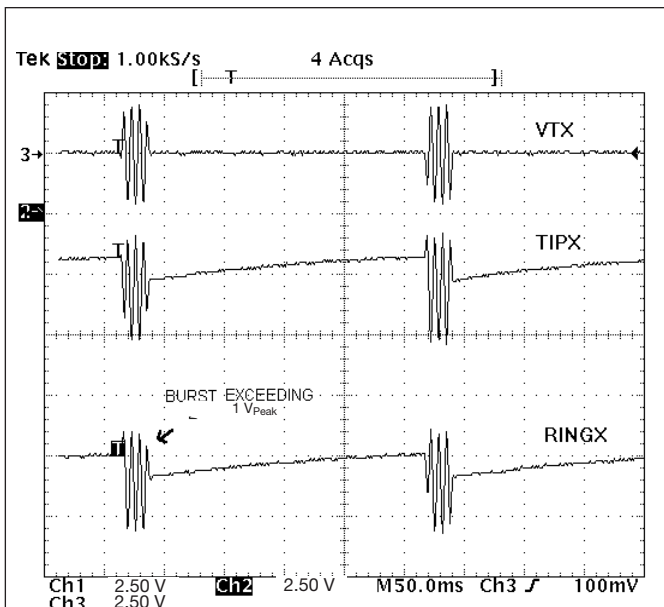

Figure 12. The AOV function. (Observe that burst is undersampled)

## Battery Feed and Automatic Battery Switching

To reduce short loop power dissipation a second lower battery voltage, Off-hook or Talk battery, must be connected to the device via an external diode at terminal VBAT. The SLIC automatically switches between the two battery supply voltages without need for external control. The silent battery switching to VBAT occurs when the line current is below 5.5 mA. This means that the current in On-hook, VBAT, battery is limited to 6 mA in the Active state. The On-hook voltage is derived from VBAT with the range of -43 V to -56 V at the TIPX and RINGX wires @  $V_{\text{Bat}} \geq -48 \text{ V}$ .

**Constant current feed region** (figure 13, curve segment A-B-C)

For TIPX to RINGX voltages  $V_{\text{TR}} < |V_{\text{TB}}| - 5.7 \text{ V}$   
where

$V_{\text{TR}}$  = the tip to ring dc voltage

$V_{\text{TB}}$  = the talk battery voltage

5.7 V = the voltage drop from  $|V_{\text{TB}}|$  to the line voltage at point C in the graph of figure 13, calculated according to:

$$0.7 \text{ V} + 3.7 \text{ V} + (27 \text{ mA} \times 2 \times 25 \text{ } \Omega) \approx 5.7 \text{ V}$$

The PBL 387 74/1 emulates constant current loop feed. The constant current value is adjustable between 18 mA and 30 mA by setting a value for resistor  $R_{\text{LC}}$ :

$$R_{\text{LC}} = \frac{500}{I_{\text{LProg}}} - \frac{10.4 \times \ln(32 \times I_{\text{LProg}})}{I_{\text{LProg}}}$$

which may be approximated by

$$R_{\text{LC}} \approx \frac{500}{I_{\text{LProg}}}$$

where

$I_{\text{LProg}}$  desired constant current in A

$R_{\text{LC}}$  programming resistance in  $\Omega$

$\ln()$  natural logarithm

**Resistive feed region** (figure 13, curve segment C-D-E)

For  $V_{\text{TR}} > |V_{\text{TB}}| - 5.7 \text{ V}$  the PBL 387 74/1 emulates resistive loop feed with feed resistance equal to  $2 \times 25 \text{ } \Omega$ . The slope of the resistive feed region is made steep to extend the constant current region as close to the talk battery voltage ( $V_{\text{TBat}}$ ) as possible.

**On-hook region** (figure 13, curve segment E-G-H-J)

For loop currents  $I_{\text{L}} < 5.5 \text{ mA}$  the PBL 387 74/1 automatically switches to feed loop current from the ring battery,  $V_{\text{Bat}}$ . The switch from talk battery,  $V_{\text{TBat}}$ , to ring battery,  $V_{\text{Bat}}$ , occurs without hysteresis at point E in figure 13. For loop currents  $I_{\text{L}}$  within the on-hook range  $0 \text{ mA} < I_{\text{L}} < 5.0 \text{ mA}$  (curve segment G-H-J) the line voltage remains nearly constant. This feature maintains a high on-hook voltage in the presence of dc line leakage currents or when a subscriber device consumes some current from the battery

feed, e.g. to power displays. The On-hook voltage tracks the  $V_{\text{BAT}}$  voltage up to  $|54.5| \text{ V}$ ,  $V_{\text{TROpen}} = |V_{\text{Bat}}| - 4.5 \text{ V}$ . For  $V_{\text{BAT}}$  higher than  $|54.5| \text{ V}$  the On-hook voltage is limited to  $|50| \text{ V}$  typical.

In the presence of leakage currents  $I_{\text{LLk}} < 5 \text{ mA}$  during on-hook: (Figure 13, curve segment G-H-J)

$$V_{\text{TROon-hook}} = V_{\text{TROpen}} - I_{\text{LLk}} \times R_{\text{Feed}} \text{ where } R_{\text{Feed}} = 2 \times 25 \text{ } \Omega$$

### Optimizing $V_{\text{TB}}$

To optimize  $V_{\text{TB}}$  with actual load on the line:

$$V_{\text{TB}} = (R_{\text{LMax}} + R_{\text{FEED}} + 2R_{\text{F}}) \times I_{\text{LProg}} + V_{\text{F}} + 3.7$$

where:

$R_{\text{Lmax}}$  is the maximum loop length including On-hook phone load

$R_{\text{Feed}}$   $2 \times 25 \text{ } \Omega$

$R_{\text{F}}$  is the resistance of one fuse resistor.

$I_{\text{LProg}}$  is the programmed line current

$V_{\text{F}}$  is the forward voltage of  $D_{\text{TB}}$  Normal value is 0.7 V

Example:  $R_{\text{Lmax}} = 600 \text{ } \Omega$ ,  $R_{\text{F}} = 40 \text{ } \Omega$ ,  $I_{\text{LProg}} = 26.8 \text{ mA}$

This will give a  $V_{\text{TB}}$  of 24 V.

### Silent Polarity Reversal

#### Polarity reversal time.

The reversal time is set by a capacitor,  $C_{\text{SPR}}$ , connected between the pin SPR and AGND. The silent polarity reversal time is the same in both directions. To calculate the silent polarity reversal time use the following formula:

$$t_{\text{r}} = C_{\text{SPR}} \times 9500$$

The reversal time is measured between the 10% and 90% values of the line voltage. The reversal time is independent of line load and line current.

#### Polarity reversal set-up time.

The set-up time is defined as the time from setting the C1, C2 and C3 inputs to the reversal state until the reversal actually commences on TIPX and RINGX.

The polarity reversal set-up time is different in the two directions, active to reversal state and reversal to active state.

The set-up time is calculated from the following expressions:

Active normal state to active reversal state:

$$t_{\text{Act} \rightarrow \text{Rev}} = C_{\text{SPR}} \times 17500$$

Active reversal state to active normal state:

$$t_{\text{Rev} \rightarrow \text{Act}} = C_{\text{SPR}} \times 15500$$

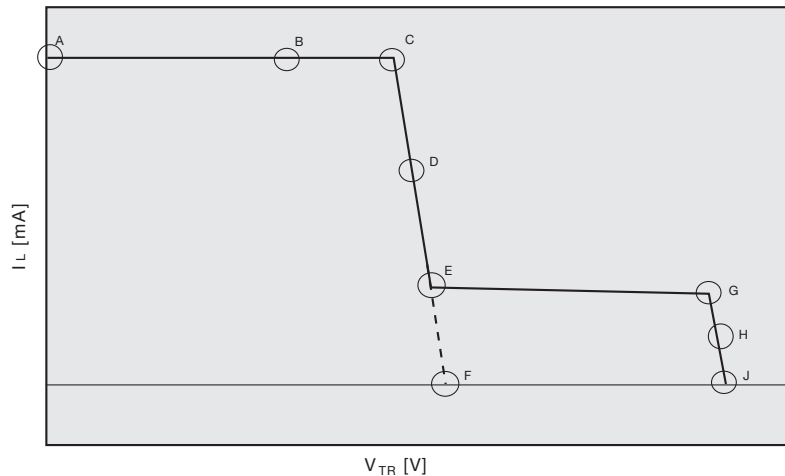

- A:  $I_L (@V_{TR}=0) = I_{Lconst} = I_{LProg}$        $R_{LC} = \frac{500}{I_{LProg}} - \frac{10.4 \times \ln(32 \times I_{LProg})}{I_{LProg}}$
- B,C:  $I_L = I_{Lconst}$ ,  $V_{TR}(@C) = V_{App} - R_{FEED} \times I_{LProg}$
- D:  $R_{FEED} = 2 \times 25 \Omega$
- E:  $I_L \approx 5.5 \text{ mA}$ ,  $V_{TR} = V_{App} - R_{FEED} \times 5.5 \text{ mA}$
- F:  $V_{App} (@I_L = 0) = V_{TB} - V_F^* - 3.7 \text{ V}$       \*  $V_F$  is the forward voltage drop across diode  $D_{TB}$
- G:  $I_L \approx 5 \text{ mA}$
- H:  $R_{FEED} = 2 \times 25 \Omega$
- J: The On-hook voltage tracks the  $V_{BAT}$  voltage up to  $|54.5| \text{ V}$ ,  $V_{TROpen} = |V_{Bat}| - 4.5 \text{ V}$ .  
For  $V_{BAT} > |54.5| \text{ V}$ ,  $V_{TROpen} = 50 \text{ V}$ .

Figure 13. Battery feed characteristics.

## Ringing Voltage

When designing PBL 387 74/1 the object was to design a robust ringing SLIC that supports balanced ringing and that handles the high power dissipation and the different fault conditions that may occur when ringing. For power handling see section Power control.

Figure 14 shows a high level schematic of the ring loop. The ring loop in the PBL 387 74/1 is designed as a voltage amplifier. An internal feedback loop from the two-wire to the input sets a predetermined voltage gain. The voltage gain is adjusted to 94 by the AGC-R when ringing. The power amplifiers are of the current feed type that makes it possible to provide a reliable control of the ringing current. This arrangement makes it possible to add a control device, including an Automatic Gain Control unit, that provides protecting functions, such as:

**Automatic Gain Control-Ringing, AGC-R:** If the amplifiers that supply Tip and Ring are forced to saturation due to i.e. variations of the  $V_{Bat}$  voltage or the  $V_R$  input signal level, the AGC-R will decrease the output signal. The shape of the output signal is kept undistorted. This function guarantees a low output impedance, approximately  $2 \times 20 \Omega$ , and also allows variations in the input signal and the  $V_{Bat}$  voltage.

**Current limit:** At off-hook or in fault conditions, i.e. Tip and Ring are shorted, the control device will limit the ringing current to approximately 10 mA above the programmed ring-trip threshold.

**Foreign voltage protection:** The control device will detect if Tip and/or Ring are shorted to e.g. ground. The output voltage will be shut off to keep the power down. The detector output will be high.

**Temperature management:** If the chip temperature exceeds 155 °C the control device will reduce the output voltage until the chip temperature equals 155 °C, and increase it again when the temperature drops. The detector output, DET, is forced to a logic low level when the temperature guard is active.

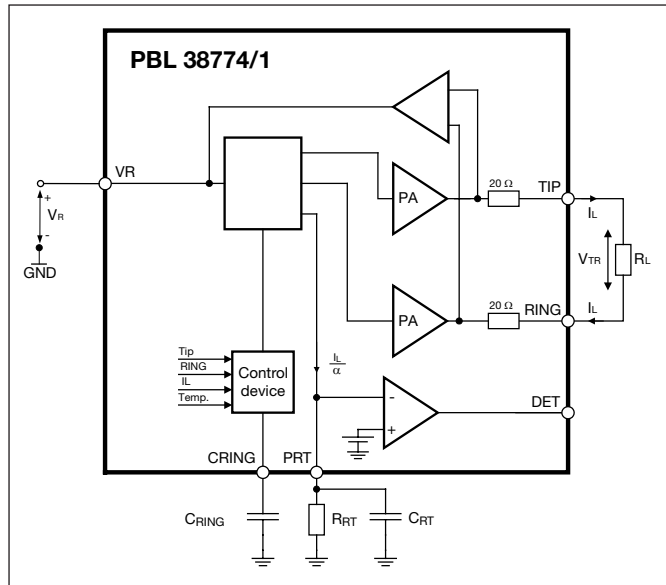

Figure 14. Ring loop schematic.

The VR pin is a high impedance input. The voltage VR has a reference to AGND. This input has to have a resistor,  $R_{VR} = 200 \text{ k}\Omega$ , connected to ground, and a capacitor,  $C_{VR} = 470 \text{ nF}$ , in series to decouple the DC component. The input handles any waveform, e.g. sinusoidal, trapezoid or square-wave shaped signals, since the SLIC acts like a linear amplifier. When using a square-wave input signal it has to be filtered and therefore add a capacitor of 10 nF parallel with the  $R_{VR}$  resistor. A DC-offset can be obtained by adding a DC part to the input signal. The capacitor  $C_{RING}$  forms a low pass filter that is an essential part of the control device. The control is used to control e.g. the applied output voltage, the ringing current or the chip temperature. The resistor  $R_{RT}$  is a programming resistor that sets the ring-trip detector threshold. The current through the resistor is a rectified version of the line current divided by a factor. The capacitor  $C_{RT}$  filters the ring-trip detection device. PRT-pin is connected to the negative input of an OP-amplifier. The positive input is connected to a reference voltage. The output of the OP-amplifier is connected to the detector output DET. When the voltage over the resistor  $R_{RT}$  exceeds the reference voltage the detector output changes state.

The ring injection will be describes in more detail with figure 15 and 16. Figure 15 shows a ring sequence with an off-hook at time t1. The first diagram shows the voltage applied to the input, VR, together with the voltages at TIPX and RINGX pins. The voltage of the TIP wire follows the voltage of the VR pin. The second diagram shows the rectified current,  $I_L/\alpha$  through the resistor  $R_{RT}$ . The dotted line represent the programmed ring-trip threshold,  $I_{LTH}/\alpha$ . The third diagram shows the voltage on the detector output. Before time t1, the phone supposed to be on-hook. The ring voltage is applied symmetrically around a fixed voltage,  $V_{Bat}/2$ , to the load. As long as the telephone is on-hook the rectified current  $I_L/\alpha$  will not exceed

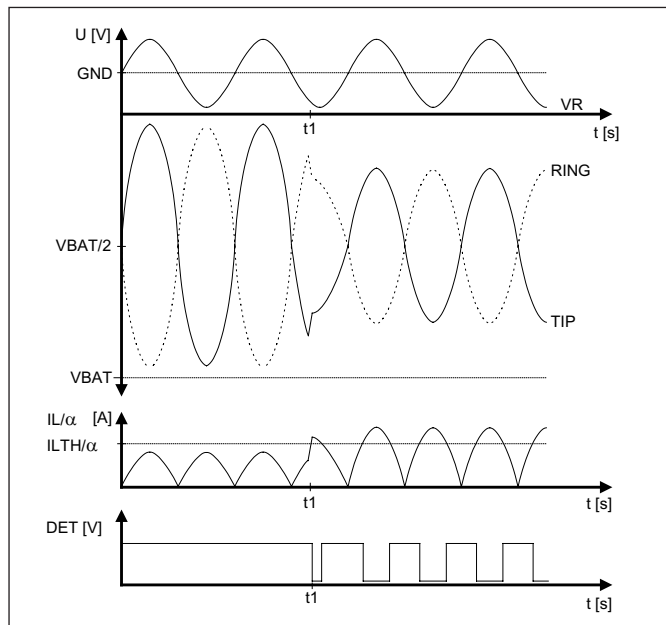

Figure 15. Off-hook during ringing.

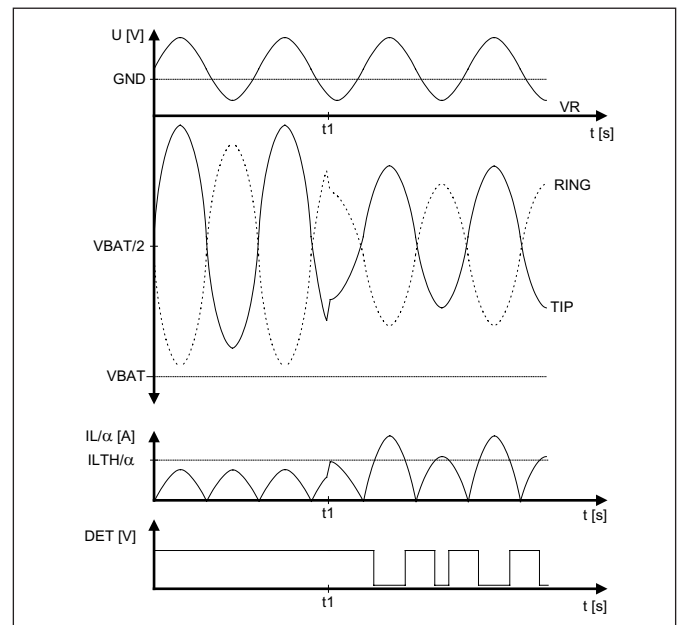

Figure 16. Off-hook during Ringing with an applied DC offset.

$I_{LTH}/\alpha$ . The DET output will be high. The control device will make sure that the voltage over the load is as high as possible without saturating the power amplifiers. When the telephone goes off-hook, at time  $t_1$ , the impedance of the load will decrease. The line current will increase and the control device will reduce the line current to a maximum of approximately 10 mA above the programmed ring-trip threshold,  $I_{LTH}$ . When the rectified current,  $I_L/\alpha$  exceeds or equals to  $I_{LTH}/\alpha$  the detector output, DET, will change to a logic low level, i.e. an off-hook. The voltage of the load will be reduced as a result of the control device limiting the line current. The figure 16 illustrates ringing with a DC offset. This method is useful when trying to extend the ring-trip capability. When programming the ring-trip threshold there must be some margin so that no false ring-trip occurs when ringing at high REN. In on-hook the DC voltage will not have any effect on the load since there is no DC path, but when the telephone goes off-hook there will be a DC path and the extra voltage will give a high ring current. This arrangement makes it possible to set a higher ringtrip threshold value and thereby gives a larger margin between the ring current in on-hook, with low RENs, and the ring current in off-hook. To keep the same amplitude on the AC signal, as when ringing without DC offset, the battery has to be increased by the same value as the programmed dc offset. The signal to VR-pin is supplies with a positive DC offset to AGN. The signal on the Tip-wire will be applied with a positive DC offset to the fixed voltage  $V_{Bat}/2$ . The signal on the Ring-wire will be applied with a negative dc offset.

### Calculation of the input signal

The VR input have to be connected to a signal generator or via impedance in all states. The following equations are valid for ring load between 0.25 and 5 REN. The optimal signal at VR pin is calculated as follows:

$$VR_{PK} = \frac{|V_{Bat}| - 3.5}{94.4} \quad (17)$$

Where:

$VR_{PK}$  is the peak value at the VR pin.

$V_{Bat}$  is the voltage of the VBAT pin.

Example:  $V_{Bat} = 80V$

This will give:  $VR_{PK} = 0.81 V_{PK}$

With DC-offset:

$$VR_{DC} = \frac{VR_{DCT-R}}{109.6} \quad (18)$$

$$VR_{PK+DC} = \frac{|V_{Bat}| - 3.5}{94.4} - VR_{DC} \quad (19)$$

Where:

$VR_{DC}$  is the positive DC offset in respect to GND at VR pin.

$VR_{DCT-R}$  is the DC voltage difference between the TIP and RING wires.

$VR_{PK+DC}$  is the peak value of the AC-signal to be superimposed to the DC-voltage  $VR_{DC}$ .

Example:  $V_{Bat} = -80V$ ,  $VR_{DCT-R} = 10V$

This will give:  $VR_{DC} = 0.091V$  and  $VR_{PK+DC} = 0.718V_{PK}$

### Calculation of the ring-trip threshold

The ring-trip threshold is calculated according to the equation:

$$R_{RT} = 3750 \times \frac{Z_{Bellmin} + 40 + 2 \times R_F + R_{Lmin}}{|V_{Bat}| \times \alpha_{Max} - 3.5} \quad (20)$$

With DC-offset:

$$R_{RT} = 3750 \times \frac{Z_{Bellmin} + 40 + 2 \times R_F + R_{Lmin}}{|V_{Bat}| \times \alpha_{Max} - 3.5 - VR_{DCT-R}} \quad (21)$$

Where:

40 is the resistance of the SLICs internal resistors connected in series with output amplifiers see figure 14.

$R_{RT}$  is the resistor value of the resistor connected between the PRT-pin and GND.

$V_{Bat}$  is the voltage of the VBAT pin.

$\alpha_{Max}$  is the variation of the battery. 2% will give an  $\alpha=1.02$ .

$Z_{Bellmin}$  is the minimum resistance of the bell in on-hook.

Typical 1400  $\Omega$  for 5 REN.

$R_F$  is the resistance of one fuse resistor.

$R_{Lmin}$  is the resistance of the minimum loop length.

$VR_{DCT-R}$  is the DC voltage difference between the Tip and Ring wire.

Example:  $V_{Bat} = -80V$ ,  $Z_{BellMin} = 1300\Omega$ ,  $\alpha_{Max} = 0\%$ ,

$R_F = 40\Omega$ ,  $VR_{DCT-R} = 0$ ,  $R_{Lmin} = 0\Omega$ ,

This will give:  $R_{RT} = 69.6k\Omega$  and a Ring-trip current threshold,

$$I_{LRth} = 57.5 \text{ mA}$$

$$I_{LRth} = \frac{4000}{R_{RT}} \quad (22)$$

## Power Dissipation Considerations

### Thermal design considerations

The thermal resistance,  $\Theta_{Ja}$ , of the PBL387 74/1 in a 28-pin SOIC package is 41.6  $^{\circ}C/W$ . The junction to ambient thermal resistance value,  $\Theta_{Ja}$ , is extracted using the SEMI standard G38-0996 and is representative of the natural airflow as seen in an application with a multilayer board. In this device the thermal resistance is lowered by using batwing pins, i.e. pins that are thermally and electrically shorted to the die. This also means that the potential of the batwing pins are the same as the substrate potential, i.e. the  $V_{Bat}$  potential. To reduce the thermal resistance in critical applications these batwing pins must be used. Typical demanding applications involves high ring voltages, high DC-offset, high REN numbers, high line currents together with high talk battery and used in high ambient temperatures. In these type of applications the batwing pins shall be soldered to a large metal layer using thermal conducting vias, i.e. small vias that will be filled with solder during the soldering process. The metal layer shall be of the order of 1sq inch and most effective is to use an outer layer, which can be cooled by convection. The PBL387 74/1 has a thermal shutdown protection at a typical temperature,  $T_{JG}$  of 155  $^{\circ}C$ , see Analog temperature guard.

There are three situations where high power dissipation occurs.

1. Ringing power dissipation on-hook
2. Ringing power dissipation off-hook
3. Off-hook power dissipation

### 1. Ringing power dissipation on-hook

The power dissipation can be calculated by the following formula:

$$P_{\text{RNG}} = P_{\text{R}} \times \frac{t_{\text{R}}}{t_{\text{R}} + t_{\text{A}}} + P_{\text{A}} \times \frac{t_{\text{A}}}{t_{\text{R}} + t_{\text{A}}}$$

where:

$P_{\text{RNG}}$	Average power during ringing.
$P_{\text{R}}$	Power in Ring state.
$P_{\text{A}}$	Power in Active state P2 in the specification typical around 65 mW
$t_{\text{R}}$	Time in Ring state
$t_{\text{A}}$	Time in Active state

Ringing is normally applied with a defined ring cadence with burst and silent intervals where the SLIC is switched between the ring and active state. Typically the time  $t_{\text{A}}$  is four times the time  $t_{\text{R}}$ . In some applications the time for the ringing and silent periods are equal, and the SLIC will dissipate more power.

The power dissipation in the SLIC for the burst can be calculated using:

$$P_{\text{R}} = P_{\text{S}} - P_{\text{Out}} =$$

For a sinusoidal shaped ring signal:

$$= \frac{2}{\pi} \times V_{\text{BAT}} \times \frac{V_{\text{Ring}}}{Z_{\text{Loop}}} - \frac{V_{\text{Ring}}^2 \times \cos\Theta_{\text{L}}}{2Z_{\text{Loop}}} + P_{\text{RingBias}}$$

where:

$P_{\text{S}}$	Supply power
$P_{\text{Out}}$	Output power
$V_{\text{BAT}}$	potential at pin
$V_{\text{Ring}}$	peak to peak voltage between tip and ring during ringing
$P_{\text{RingBias}}$	power dissipation in ring state without load, typical value 0.3 W
$Z_{\text{Loop}}$	total line impedance, including fuse and the telephone impedance (in this case the on-hook resistance)

$Z_{\text{Loop}}$  can be calculated using:

$$Z_{\text{Loop}} = \sqrt{(R_{\text{Line}} + R_{\text{Bell}} + 2R_{\text{F}})^2 + \left(\frac{1}{2\pi \times f_{\text{Ring}} \times C_{\text{Bell}}}\right)^2}$$

where:

$R_{\text{Line}}$	line resistance, typical 0-500 $\Omega$ .
$R_{\text{Bell}}$	total bell resistance
$R_{\text{F}}$	fuse and protection resistance, typical 40 $\Omega$ .
$f_{\text{Ring}}$	ring frequency
$C_{\text{Bell}}$	total bell capacitance

$$\Theta_{\text{L}} = -\alpha \tan \left( \frac{1/(2\pi \times f_{\text{Ring}} \times C_{\text{Bell}})}{R_{\text{CU}} + R_{\text{Bell}} + 2R_{\text{F}}} \right)$$

Example:

Calculate the SLIC power dissipation and junction temperature when  $V_{\text{Bat}} = -80$  V, 5REN, line resistance = 0  $\Omega$ , protection resistance =  $2 \times 40$   $\Omega$  and ring cadence is 1:1.

Ambient temperature is 85  $^{\circ}\text{C}$ .

Typical values in North America can be for 5 REN:

$$R_{\text{Bell}} = 1386 \Omega, C_{\text{Bell}} = 40 \mu\text{F}, f_{\text{Ring}} = 20 \text{ Hz.}$$

$$Z_{\text{Loop}} = \sqrt{(0 + 1386 + 2 \times 40)^2 + \left(\frac{1}{2\pi \times 20 \times 40 \times 10^{-6}}\right)^2} = 1479 \Omega$$

$$V_{\text{Ring}} = V_{\text{BAT}} - 3.5 = 76.5 \text{ V}$$

The phase shift is very small so  $\cos(\Theta_{\text{L}})$  is very near one and the formula above is simplified to:

$$P_{\text{R}} = \frac{2}{\pi} \times V_{\text{Bat}} \times \frac{V_{\text{Ring}}}{Z_{\text{Loop}}} - \frac{V_{\text{Ring}}^2}{2Z_{\text{Loop}}} + P_{\text{RingBias}} =$$

$$= \frac{2}{\pi} \times 80 \times \frac{76.5}{1479} - \frac{76.5^2}{2958} + 0.3 = 0.96 \text{ W}$$

$$P_{\text{RNG}} = 0.96 \times \frac{1}{1+1} + 0.065 \times \frac{1}{1+1} = 0.51 \text{ W}$$

The  $\Theta_{\text{ja}} = 41.6$   $^{\circ}\text{C}/\text{W}$  and ambient temperature = 85  $^{\circ}\text{C}$ .

$$T_{\text{j}} = 0.51 \times 41.6 + 85 = 106.2 \text{ }^{\circ}\text{C}$$

which is less than the thermal protection at 155  $^{\circ}\text{C}$ .

### 2. Ringing power dissipation off-hook

Using the same formula as above and 300  $\Omega$  as the off-hook load the result will indicate several Watts of power dissipation. In that case the SLIC will limit the current to approx. 10 mA above the programmed ring-trip threshold, see section Calculation of the ring-trip threshold. If the system do not force the SLIC in to Active state the temperature guard will be activated and the detector output, DET, will stay low.

### 3. Off-hook power dissipation

The maximum off-hook power dissipation is dependent on the  $V_{\text{TB}}$  voltage, the line current  $I_{\text{L}}$  and the loop resistance  $R_{\text{Loop}}$ . The power dissipation in the SLIC can be calculated using:

$$P_{\text{Off-hook}} = P_{\text{S}} - P_{\text{Out}} = V_{\text{TB}} \times I_{\text{L}} + P_{\text{q}} - I_{\text{L}}^2 \times R_{\text{Loop}}$$

$P_{\text{S}}$	Supply power
$P_{\text{Out}}$	Output power
$I_{\text{L}}$	programmed line current
$P_{\text{q}}$	quiescent power, approx 65 mW
$R_{\text{Loop}}$	the total line resistance, including fuse and the telephone impedance, in this case the off-hook resistance

Example:

Calculate the SLIC power dissipation and junction temperature when  $V_{\text{TB}} = -24$  V, Programmed line current 27 mA, Off-hook resistance = 200  $\Omega$ , line resistance = 0  $\Omega$ , protection resistance =  $2 \times 40$   $\Omega$ . Ambient temperature is 85  $^{\circ}\text{C}$ .

$$P_{\text{Off-hook}} = 24 \times 0.027 + 0.065 - (0.027)^2 \times (200 + 0 + 2 \times 40) = 0.51 \text{ W}$$

The junction temperature is calculated like the previous example.

## Loop Monitoring Functions

The loop current, ground key and ring-trip detectors report their status through a common output, DET. The particular detector to be connected to the detector pin, DET, is selected via the three bit control interface C1, C2 and C3. Please refer to section Control Inputs for a description of the control interface.

### Detector Output (DET)

The PBL 387 74/1 SLIC incorporates a detector output driver designed as an open collector (npn), an internal 10 k $\Omega$  pull-up resistor to VCC. The emitter of the drive transistor is connected to AGND. The logic high, 1, level is 5 V and the logic low, 0, is AGND.

### Loop Current Detector

The loop current detector indicates that the telephone is off-hook and that dc current is flowing in the loop by setting the output pin DET to a logic low level when selected. The loop current detector threshold value,  $I_{LTh}$ , where the loop current detector changes state, is programmable with the  $R_{LD}$  resistor.  $R_{LD}$  connects between pin PLD and ground and is calculated according to:

$$R_{LD} = \frac{500}{I_{LTh}}$$

The loop current detector is internally filtered and is not influenced by the ac signal at the two-wire side. In the Tip Open Circuit state the DET output changes to logic low state when the RINGX current exceeds  $I_{LTh}$ .

### Ground Key Detector, Loop Ground Fault Detector

The ground key detector circuit senses the difference between TIPX and RINGX currents. When triggered the output pin DET is set to a logic high level. The detector is triggered when the difference exceeds the internally set and fixed current threshold. Diagnostics: loop ground faults can be detected by the ground key detector.

### Loop voltage measurement

The loop voltage,  $V_{TR}$  (V), is presented at the DET output as a pulse train with a repetition frequency,  $f_V$  (Hz), which is inversely proportional to the voltage according to:

$$f_V = \frac{10^6}{(|V_{TR}| + 1)}$$

The loop voltage measurement commences when commanding the SLIC into the loop voltage measurement state from any other state (refer to Table 1, SLIC operating states). Loop diagnostic purposes and setting line card gain are two examples of uses for the loop voltage information.

## Control Inputs

The PBL 387 74/1 SLIC has three digital control inputs, C1, C2 and C3. A decoder in the SLIC interprets the control input condition and determining the commanded operating state. C1, C2 and C3 are internal pull-up inputs. The logic inputs are compatible with a 3.3V logic interface.

### Open circuit state (C3, C2, C1 = 0,0,0)

In the Open Circuit State the TIPX and RINGX line drive amplifiers as well as other circuit blocks are powered down. This causes the SLIC to present a high impedance to the line. Power dissipation is at a minimum and no detectors are active. DET output is set high.

### Ringling state (C3, C2, C1 = 0,0,1)

The low voltage ringing signal, which is connected to VR, is amplified and appears at TIPX and RINGX as a balanced high voltage ring signal. The ring-trip detector monitors hook status and sets the DET output low when off-hook line status is detected.

### Active state (C3, C2, C1 = 0,1,0)

TIPX is the terminal closest to ground and sources loop current while RINGX is the more negative terminal and sinks loop current. The loop current detector is activated. The loop current detector indicates off-hook with a logic low level present at the detector output.

### Active state, loop voltage measurement

(C3, C2, C1 = 0,1,1)

A frequency inversely proportional to the line voltage will appear at the DET output when the PBL 387 74/1 is set to the active, loop voltage measurement state.

### TIPX open state (C3, C2, C1 = 1,0,0)

In the TIPX open state the TIPX pin is set to present a high impedance, while the RINGX lead is active and able to sink current. The DET output monitors RINGX current level and changes to low state when the RINGX current exceeds the threshold current set by  $R_{LD}$  (pin PLD). This operating state is used for interfaces which require ground start signaling.

### Active state, ground key and Loop Ground Fault

Detector (C3, C2, C1 = 1,0,1)

TIPX is the terminal closest to ground and sources loop current while RINGX is the more negative terminal and sinks loop current. The ground key detector is activated. The ground key detector will indicate active ground key with a logic high level present at the detector output. This state is also used for a diagnostic function as loop ground faults can be detected by the ground key detector

### Active polarity reversal state, loop current detector (C3, C2, C1 = 1,1,0)

TIPX and RINGX polarity is reversed compared to the Active State: RINGX is the terminal closest to ground and sources loop current while TIPX is the more negative terminal and sinks current. The loop current detector is activated. The loop current detector will indicate off-hook with a logic low level present at the detector output.

### Active polarity reversal state, ground key detector and Loop Ground Fault Detector (C3, C2, C1 = 1,1,1)

TIPX and RINGX polarity is reversed compared to the Active State: RINGX is the terminal closest to ground and sources loop current while TIPX is the more negative terminal and sinks current. The ground key detector is activated. The ground key detector will indicate active ground key with a logic high level present at the detector output. This state is also used for a diagnostic function as loop ground faults can be detected by the ground key detector.

## Overtemperature and Overvoltage Protection

### Analog temperature guard

The varying environmental conditions in which SLICs operate in conjunction with fault conditions may lead to the chip maximum temperature limitation being exceeded. The PBL 387 74/1 SLIC reduces the dc line current and the longitudinal current when the chip temperature reaches approximately 155°C and increases the line current again automatically when the chip temperature drops. Due to the linear nature of the chip temperature regulation (e.g. dc loop current partially reduced) a talk path may still be functional while the temperature guard is active. The detector output, DET, is forced to a logic low level while the temperature guard is active.

### Overvoltage protection - general

PBL 387 74/1 must be protected against foreign voltages on the telephone line. Overvoltages can result from lightning, ac power contact, induction and other causes. Refer to Maximum Ratings, TIPX and RINGX terminals, for maximum continuous and transient voltages that the SLIC TIPX and RINGX terminals can withstand. Overvoltage protection consists of primary protection located outside of the line card (e.g. gas tubes in a main distribution frame) and secondary protection (series line resistors and solid state clamping devices such as diodes and thyristors) located on the linecard printed circuit board.

### Secondary protection

The circuit shown in figure 9 utilizes series resistors ( $R_{F1}$ ,  $R_{F2}$ ) together with a programmable overvoltage protector (OVP, e. g. Power Innovations TISP PBL3 or TISP6NTP2AD) as secondary protection.

The TISP PBL3 is a dual forward-conducting buffered p-gate overvoltage protector. The protector gate references the protection (clamping) voltage to the negative supply voltage (i.e. the battery voltage,  $V_{BAT}$ ). As the protection voltage will track the negative supply voltage the overvoltage stress on the SLIC is minimized. Positive overvoltages are clamped to ground by a diode. Negative overvoltages are initially clamped close to the SLIC negative supply rail voltage and the protector will crowbar into a low voltage on-state condition, by firing an internal thyristor.

A gate decoupling capacitor,  $C_{GG}$ , is needed to carry enough charge to supply a high enough current to quickly turn on the thyristor in the protector.  $C_{GG}$  should be placed close to the overvoltage protection device. Without the capacitor even the low inductance in the track to the  $V_{BAT}$  supply will limit the current and delay the activation of the thyristor clamp. The line protection resistors  $R_{F1}$  and  $R_{F2}$  serve the dual purposes of being non- destructing energy dissipators when transients are clamped and of being fuses when the line is exposed to a power cross. If longitudinal balance requirements permit, PTC resistors may be used for  $R_{F1}$  and  $R_{F2}$ . Note, however, that it is important to use fixed resistors in series with PTCs since PTCs are capacitive. Fast transients will therefore experience much less PTC impedance than do slower transients. Relying only on PTCs as the current limiting element could therefore result in excessive fast transient current through the clamp, with possible clamp current overload and resulting inability to protect the SLIC. A value of approximately 40  $\Omega$  for each of  $R_{F1}$  and  $R_{F2}$  limits the peak overvoltage transient current to a value that is compatible with the clamping device (OVP block in figure 9.) capability. Higher resistance values for  $R_{F1}$  and  $R_{F2}$  than 40  $\Omega$  will require more stringent matching of the  $R_{F1}$  and  $R_{F2}$  resistors and will also have a much greater impact on terminating impedance, gains and dc loop resistance. Lower resistance values for  $R_{F1}$  and  $R_{F2}$  than 40  $\Omega$  will result in peak clamp currents that may exceed the capability of standard clamping devices.

## Power-up Sequence

No special power-up sequence is necessary except that ground has to be present before all other power supply voltages. The digital inputs C1, C2 and C3 are internal pull-up terminals.

## Printed Circuit Board Layout

Care in Printed Circuit Board (PCB) layout is essential for proper function. The components connection RSN input should be placed in close proximity to that pin, such that no interference is injected into the receive summing node (RSN). Ground plane surrounding the RSN pin is advisable. Analog Ground (AGND) should be connected to Battery Ground (BGND) near the SLIC package.  $R_{LC}$  and  $R_{REF}$  should be connected to AGND with short leads. Pin LP and HP are sensitive to leakage currents. The CLP connection between pins LP and VBAT should be as short as possible.  $C_B$  and  $C_{TB}$  must be connected near the pins VBAT and VBAT with short vias to ground. The batwing pins are internally connected to VBAT and used for transferring the heat from the chip to the printed circuit board. It is therefore advisable to implement a PCB layout that facilitates heat conduction away from the batwing pins.

**Mechanical drawing**

All dimensions are in mm

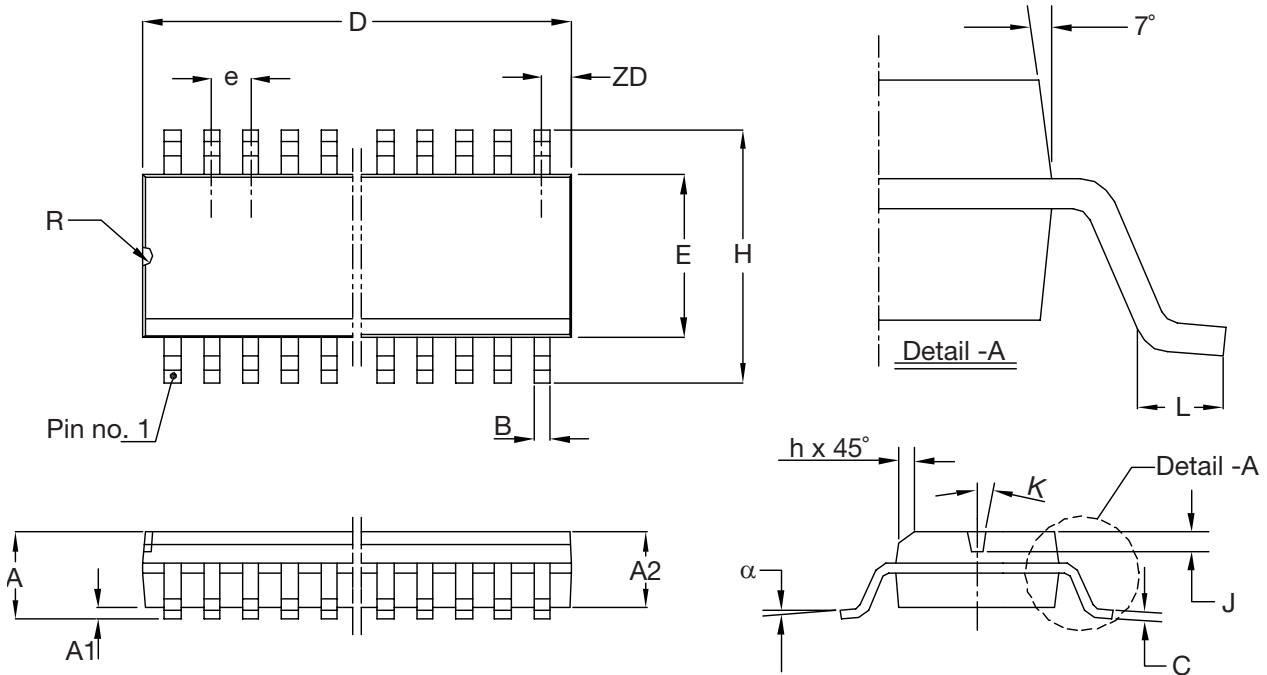

SOIC 28LD		
DIM	Min	Max
A	2.44	2.64
A1	0.10	0.30
A2	2.24	2.44
B	0.36	0.46
C	0.23	0.32
D	17.73	17.93
E	7.40	7.60
e	1.27 BSC	
H	10.11	10.51
h	0.31	0.71
J	0.53	0.73
K	7° BSC	
L	0.51	1.01
R	0.63	0.89
alpha	0°	8°
ZD	0.66 REF	

Figure 17. Mechanical drawing.

## Ordering Information

Package	Temp. Range	Part No.
28-pin SOIC Tape & Reel	-40° - +85° C	PBL 387 74/1SOD or SOA

Information given in this data sheet is believed to be accurate and reliable. However no responsibility is assumed for the consequences of its use nor for any infringement of patents or other rights of third parties which may result from its use. No license is granted by implication or otherwise under any patent or patent rights of Ericsson Microelectronics AB. These products are sold only according to Ericsson Microelectronics general conditions of sale, unless otherwise confirmed in writing.

Specifications subject to change without notice.

This product is an original Ericsson product protected by US, European and other patents.

**Ericsson Microelectronics**  
SE-164 81 KISTA, Sweden  
Phone: +46 8 757 5000  
[www.ericsson.com/microelectronics](http://www.ericsson.com/microelectronics)

For local sales contacts, please refer to our website  
or call: Int. +46 8 757 4700, Fax: +46 8 757 4776

Preliminary Data Sheet

EN/LZT 146 138 R1A  
© Ericsson Microelectronics AB, January 2002