

DESCRIPTION

The NE584 is a Cathode Driver for multiplexed, 7-segment gas discharge displays.

The display segments are driven by floating current sources maintaining uniform brightness across the display panel with a minimum of system components as shown in the Display Drivers illustration. A current feedback circuit is included to adjust the anode voltage steady under optimum load conditions. The maximum voltage ripple is typically held to less than 1V.

FEATURES

- Capable of driving up to 9 segments
- 1 external resistor provides for current programming
- Minimum component count for system cost effectiveness
- Segment current programmability for optimum operation of all character sizes
- Internal current limiting protection
- Internal feedback network ensures optimum operating conditions
- High system reliability
- Compatible with MOS and TTL inputs

ABSOLUTE MAXIMUM RATINGS

PARAMETER	RATING	UNIT
V_{B-} Supply voltage		V
V_{B-} Negative	-110	
V_{CC} Logic	+15	
V_{IN} Input voltage	+15	V
I_P Program current	1	mA
T_J Junction temperature	150	°C
T_A Ambient operating temperature range	0 to 70	°C
T_S Storage temperature range	-65 to 150	°C
T_{sold} Soldering temperature (10sec)	300	°C
P_D Power dissipation at 25°C		mW
Plastic DIP—22 and 24 pin	1000	
Cerdip—22 and 24 pin	1200	

DISPLAY DRIVERS

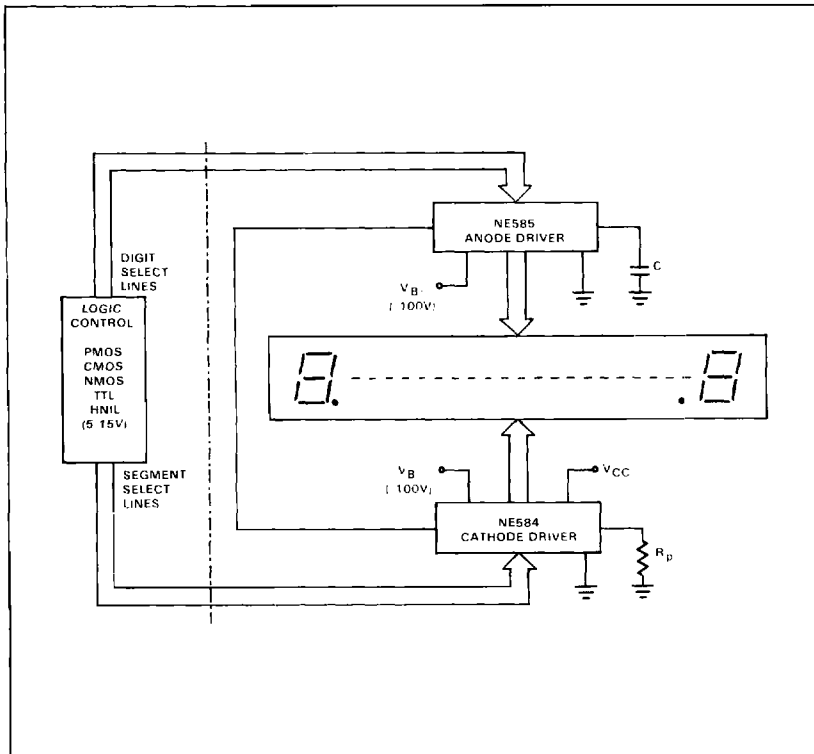

PIN CONFIGURATION

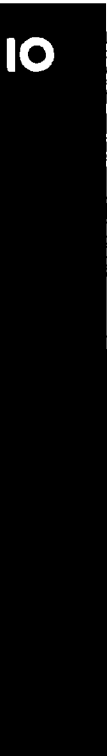
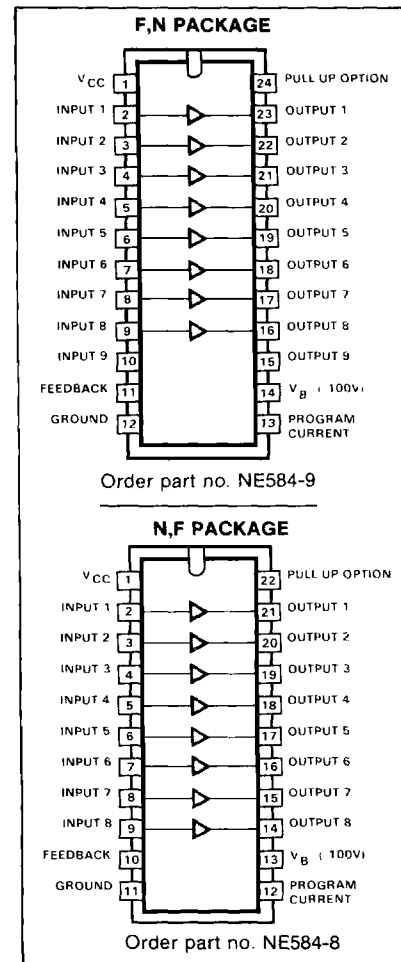

DC ELECTRICAL CHARACTERISTICS $V_{B-} = -100V$, $V_{CC} = 5$ to $15V$

PARAMETER	TEST CONDITIONS	LIMITS			UNIT
		Min	Typ	Max	
V_{B-} Supply voltage	Operating voltage range	-90	-100	-110	V
V_{IH} High V_{IL} Low	For TTL type inputs	2.6		1.1	V
I_I Input current	$V_{IN} = 2.6V$ $V_{IN} = 6V$ $V_{IN} = 15V$	115 340	60 230 680	200 460 1360	μA
I_{IH} High I_{IL} Low	For MOS type inputs	90		5	
Current ratio between any 2 outputs	$T_A = 25^\circ C$, $I_P = 200$ or $600\mu A$.9	1	1.1	mA
Output current to program current ratio	$I_P = 200$ or $600\mu A$ $T_A = 25^\circ C$ $T_A = 0-70^\circ C$	4.5 4	5 5	5.5 6	mA
V_{OUT} Output voltage On	$I_P = 100\mu A$, $I_{Seg} = 450\mu A$ $I_P = 100\mu A$, $I_{Seg} = 1\mu A$ $I_P = 600\mu A$, $I_{Seg} = 2.7mA$ $I_P = 600\mu A$, $I_{Seg} = 1\mu A$		5 1 14 3		V
Off On breakdown Off breakdown	With respect to V_{B-} $I_P = 400\mu A$, $I_{Seg} = 3mA$ $I_{Seg} = 10\mu A$	90	$V_{B-} + 40$ $V_{B-} + 55$		
Output leakage current Off	$I_{OUT} = V_{B-} + 90V$			10	μA
I_f Feedback current	$I_P = 200\mu A$, $V_{IN} \geq 3.5V$, $I_{Seg} = 0$ 1 segment on 8 segments on	140 1.1	200 1.6	260 2.1	μA mA
Propagation delay	$C_{OUT} = 15pF$		5		μs
I_{CC} Power supply current I_{B-} Logic Negative	All inputs low, $V_{FB} = 15V$, $I_P = 100\mu A$, $V_{CC} = 15V$		1	3 2	mA
Pull up option current	$V_{CC} = 5V$. Pin 24 or 22 = 0V		0.6		mA

EQUIVALENT SCHEMATIC

