

**DUAL OPERATIONAL AMPLIFIERS****AZ4558****General Description**

The AZ4558 consists of two high performance operational amplifiers. The IC features high gain, high input resistance, excellent channel separation, wide range of operating voltage and internal frequency compensation. It can work with $\pm 18V$ maximum power supply voltage.

The AZ4558 is specifically suitable for applications in differential-in, differential-out as well as in potential-metric amplifiers and where gain and phase matched channels are mandatory.

The AZ4558 is available in DIP-8 and SOIC-8 package.

Features

- Internal Frequency Compensation
- Large Signal Voltage Gain with 100 dB Typical
- High Input Resistance with $5M\Omega$ Typical
- Maximum Power Supply Voltages: $\pm 18V$
- Compatible with NJM 4558
- Low Input Voltage Noise with $10nV/\sqrt{Hz}$ at 1KHz

Applications

- Audio AC-3 Decoder System
- Audio Amplifier

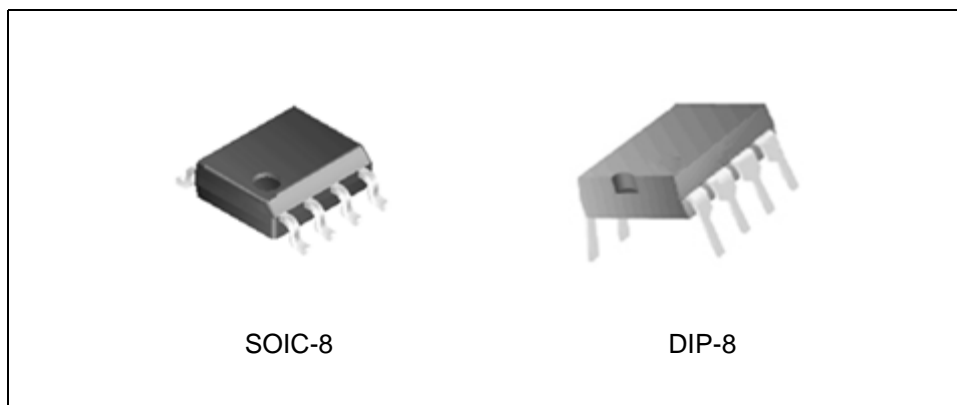

Figure 1. Package Types of AZ4558



DUAL OPERATIONAL AMPLIFIERS

AZ4558

Pin Configuration

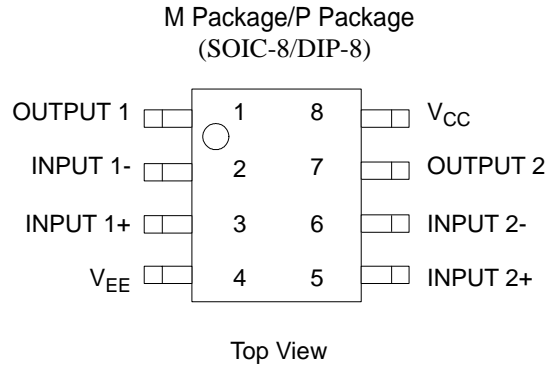

Figure 2. Pin Configuration of AZ4558

Functional Block Diagram

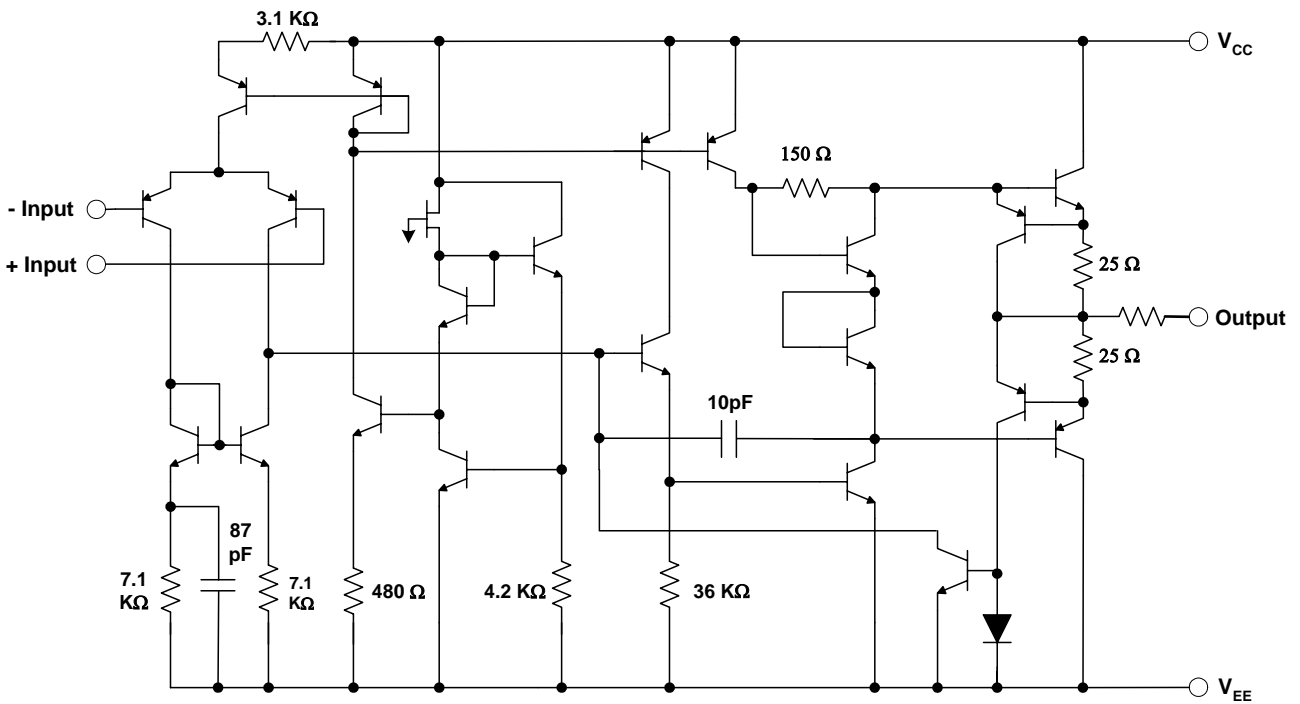

Figure 3. Representative Schematic Diagram of AZ4558 (Each Amplifier)



DUAL OPERATIONAL AMPLIFIERS

AZ4558

Ordering Information

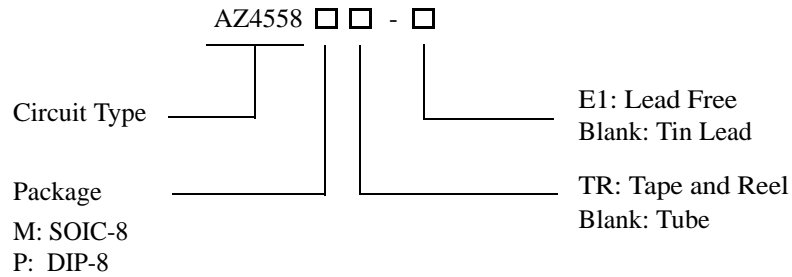

Package	Temperature Range	Part Number		Marking ID		Packing Type
		Tin Lead	Lead Free	Tin Lead	Lead Free	
SOIC-8	-40 to 85°C	AZ4558M	AZ4558M-E1	4558M	4558M-E1	Tube
		AZ4558MTR	AZ4558MTR-E1	4558M	4558M-E1	Tape & Reel
DIP-8	-40 to 85°C	AZ4558P	AZ4558P-E1	AZ4558P	AZ4558P-E1	Tube

BCD Semiconductor's Pb-free products, as designated with "E1" suffix in the part number, are RoHS compliant.

**DUAL OPERATIONAL AMPLIFIERS****AZ4558****Absolute Maximum Ratings (Note 1)**

Parameter	Symbol	Value		Unit
Power Supply Voltage	V_{CC}	+20		V
	V_{EE}	-20		
Input Voltage	V_I	± 15		V
Differential Input Voltage	V_{ID}	± 30		V
Operating Junction Temperature	T_J	150		$^{\circ}\text{C}$
Storage Temperature Range	T_{STG}	-65 to 150		$^{\circ}\text{C}$
Lead Temperature (Soldering 10s)	T_L	260		$^{\circ}\text{C}$
Power Dissipation	P_D	DIP-8	800	mW
		SOIC-8	500	

Note 1: Stresses greater than those listed under "Absolute Maximum Ratings" may cause permanent damage to the device. These are stress ratings only, and functional operation of the device at these or any other conditions beyond those indicated under "Recommended Operating Conditions" is not implied. Exposure to "Absolute Maximum Ratings" for extended periods may affect device reliability.

Recommended Operating Conditions

Parameter	Min	Max	Unit
Supply Voltage	± 4	± 18	V
Operating Temperature Range	-40	85	$^{\circ}\text{C}$



DUAL OPERATIONAL AMPLIFIERS

AZ4558

Electrical Characteristics

Operating Conditions: $V_{CC}=+15V$, $V_{EE}=-15V$, $T_A=25^{\circ}C$ unless otherwise specified.

Parameter	Conditions	Min	Typ	Max	Unit
Input Offset Voltage			0.5	6	mV
Input Bias Current	$V_{CM}=0V$		25	250	nA
Input Offset Current	$V_{CM}=0V$		2.5	100	nA
Input Resistance		0.3	5		MΩ
Supply Current	$R_L=\infty$, Over full temperature range		3.3	5.7	mA
Large Signal Voltage Gain	$R_L \geq 2K$, $V_O = \pm 10V$	85	100		dB
Common Mode Rejection Ratio	$R_S \leq 10k\Omega$	80	92		dB
Power Supply Rejection Ratio	$R_S \leq 10k\Omega$	80	95		dB
Output Current	Source $V_+=1V, V_-=0V, V_O=2V$		50		mA
	Sink $V_+=0V, V_-=1V, V_O=2V$		50		mA
Output Voltage Swing	$R_L \geq 2K\Omega$	± 10	± 13		V
	$R_L \geq 10K\Omega$	± 12	± 14		
Slew Rate	$R_L=2K\Omega, C_L=100pF$		1.3		V/ μS
Equivalent Input Noise Voltage Density	$R_S=50\Omega, f=1KHz$		10		nV/ \sqrt{Hz}
Gain Bandwidth Product	$R_L=2K\Omega, f=10KHz$		3.4		MHz



DUAL OPERATIONAL AMPLIFIERS

AZ4558

Typical Performance Characteristics

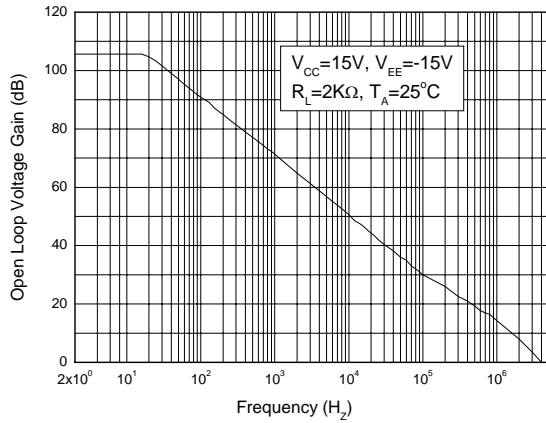

Figure 4. Open Loop Voltage Gain vs. Frequency

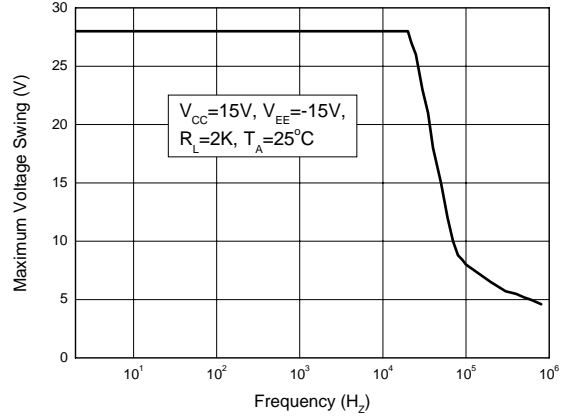

Figure 5. Maximum Output Voltage Swing vs. Frequency

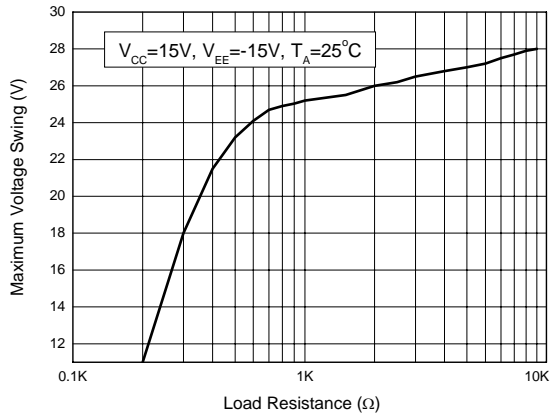

Figure 6. Maximum Output Voltage Swing vs. Load Resistance

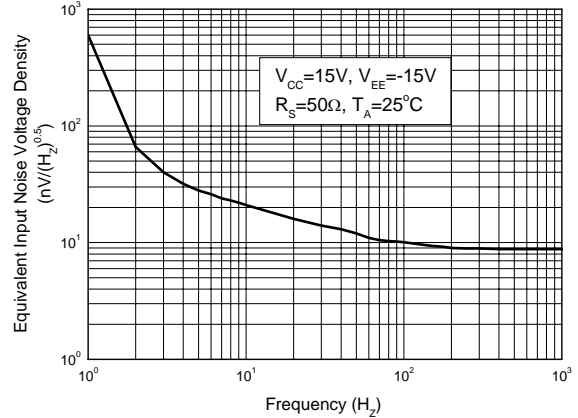

Figure 7. Equivalent Input Noise Voltage Density vs. Frequency



DUAL OPERATIONAL AMPLIFIERS

AZ4558

Typical Performance Characteristics (Continued)

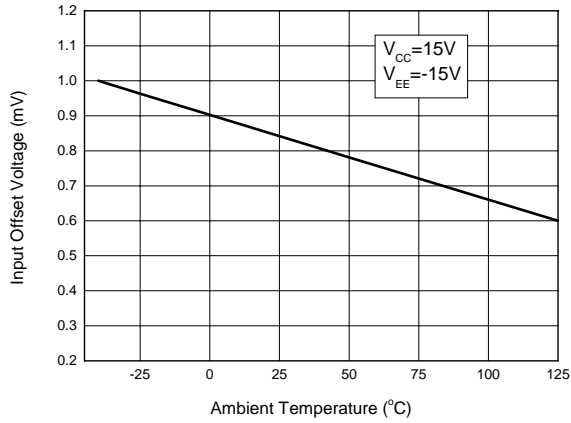

Figure 8. Input Offset Voltage vs. Temperature

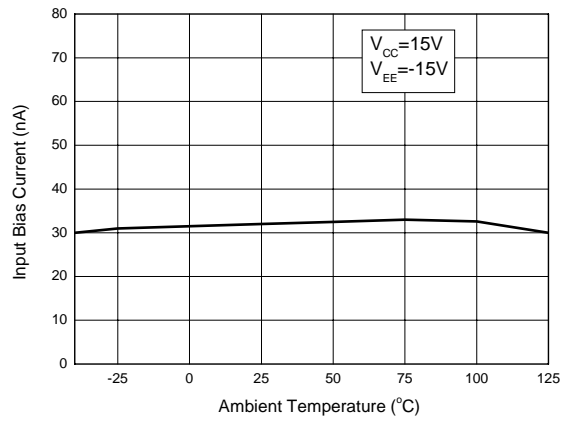

Figure 9. Input Bias Current vs. Temperature

Typical Application

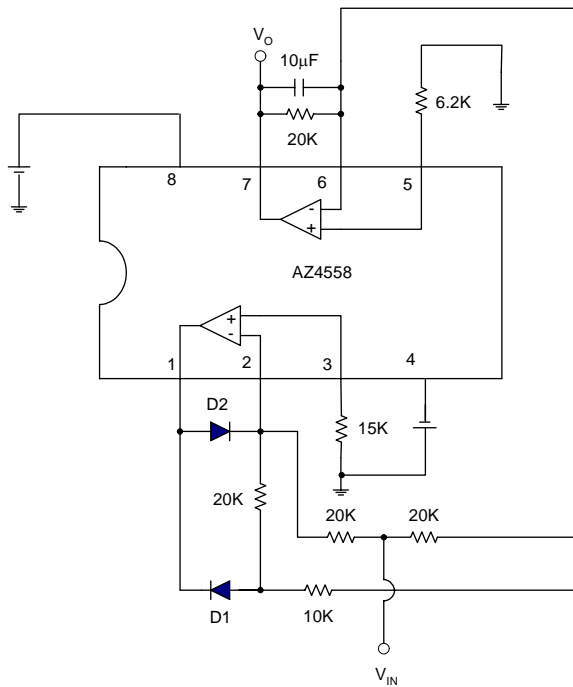

Figure 10. Application of AZ4558 in an AC/DC Converter



DUAL OPERATIONAL AMPLIFIERS

AZ4558

Mechanical Dimensions

DIP-8

Unit: mm(inch)

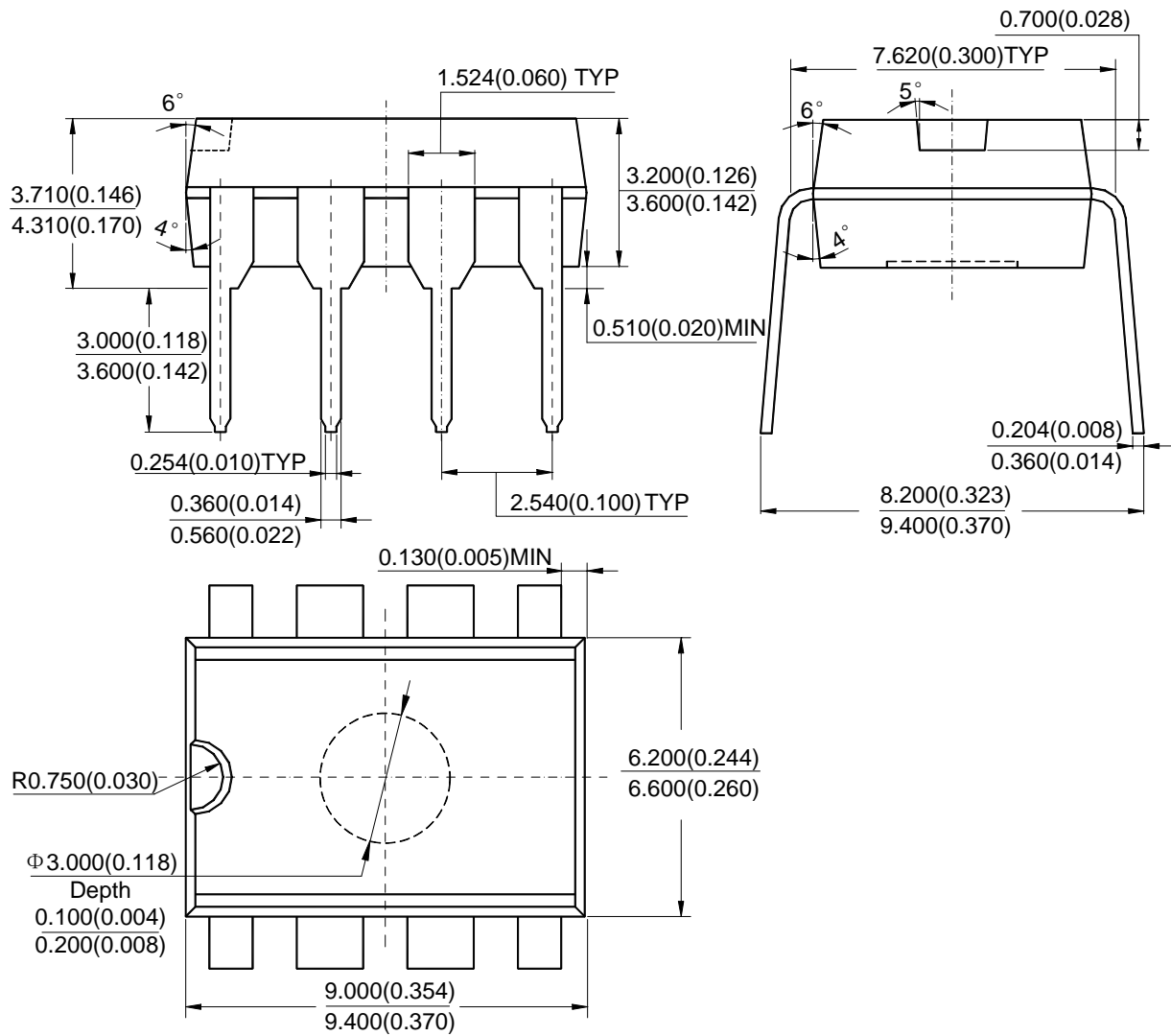



BCD Semiconductor Manufacturing Limited

<http://www.bcdsemi.com>

IMPORTANT NOTICE

BCD Semiconductor Manufacturing Limited reserves the right to make changes without further notice to any products or specifications herein. BCD Semiconductor Manufacturing Limited does not assume any responsibility for use of any its products for any particular purpose, nor does BCD Semiconductor Manufacturing Limited assume any liability arising out of the application or use of any its products or circuits. BCD Semiconductor Manufacturing Limited does not convey any license under its patent rights or other rights nor the rights of others.

MAIN SITE

BCD Semiconductor Manufacturing Limited
- Wafer Fab
Shanghai SIM-BCD Semiconductor Manufacturing Limited
800, Yi Shan Road, Shanghai 200233, China
Tel: +86-21-6485 1491, Fax: +86-21-5450 0008

BCD Semiconductor Manufacturing Limited
- IC Design Group
Advanced Analog Circuits (Shanghai) Corporation
8F, Zone B, 900, Yi Shan Road, Shanghai 200233, China
Tel: +86-21-6495 9539, Fax: +86-21-6485 9673

REGIONAL SALES OFFICE

Shenzhen Office
Shanghai SIM-BCD Semiconductor Manufacturing Co., Ltd. Shenzhen Office
Advanced Analog Circuits (Shanghai) Corporation Shenzhen Office
Room E, 5F, Noble Center, No.1006, 3rd Fuzhong Road, Futian District, Shenzhen 518026, China
Tel: +86-755-8826 7951
Fax: +86-755-8826 7865

Taiwan Office
BCD Semiconductor (Taiwan) Company Limited
4F, 298-1, Rui Guang Road, Nei-Hu District, Taipei, Taiwan
Tel: +886-2-2656 2808
Fax: +886-2-2656 2806

USA Office
BCD Semiconductor Corporation
30920 Huntwood Ave. Hayward, CA 94544, U.S.A
Tel : +1-510-324-2988
Fax: +1-510-324-2788