

DESCRIPTION

The Silicon Systems 73M2910 high performance microcontroller is based on the industry standard 8-bit 8052 implemented in Silicon Systems' advanced submicron CMOS process. The processor has the same attributes of the 8052 including Instruction cycle time, UART, timers, interrupts, 256 bytes of on-chip RAM and programmable I/O. The architecture has been optimized for low power portable modem or communication applications by integrating unique features with the core CPU.

The main feature is a user friendly HDLC packetizer, accessed through the special function registers. It has a serial I/O, hardware support for 16- and 32-bit CRC, zero insert/delete control, a dedicated interrupt and a clear channel mode for by-passing the packetizer.

Other features include additional user programmable I/O with programmable bank select and chip select logic, designed to eliminate board level glue logic. It also includes two general purpose input ports with programmable wakeup capability.

For devices that require non-multiplexed address and data buses, eight latched outputs for the low byte of the address are available.

(continued)

FEATURES

- 8052 Compatible Instruction set
- 34 MHz Operation @ 4.5 – 5.5V
- 44 MHz Operation @ 4.75 – 5.5V (2910A)
- 22 MHz Operation @ 3.3 – 5.5V
- HDLC Support logic (Packetizer, 16 and 32 CRC, zero ID)
- 24 pins for user programmable I/O ports
- 8 pins programmable chip select logic or I/O for memory mapped peripheral eliminating glue logic
- 3 external Interrupt sources (programmable polarity)
- 16 dedicated latched address pins
- Multiplexed data/address bus
- Instruction cycle time identical to 8052
- Buffered oscillator (or OSC/2) output pin
- 1.8432 MHz UART clock available
- Bank select circuitry to support up to 128K of external program memory
- 100-Lead TQFP package available for PCMCIA applications
- Also available in 100-Lead QFP package



BLOCK DIAGRAM

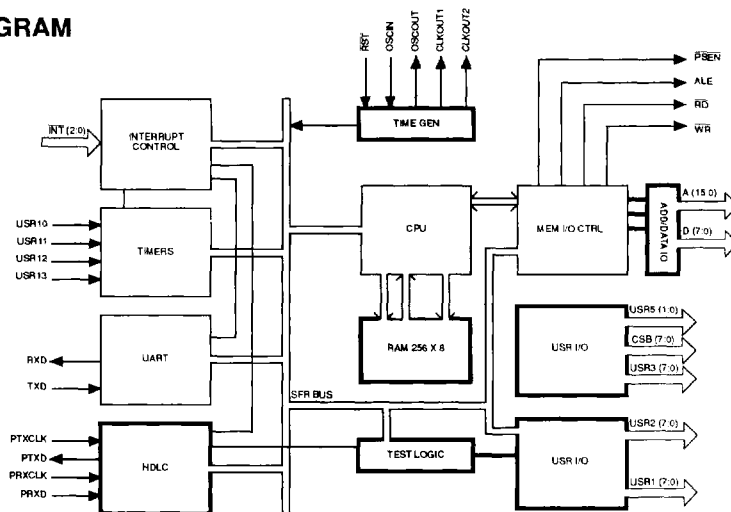

SSI 73M2910/2910A

Microcontroller

DESCRIPTION (continued)

The 73M2910 has two extra interrupt sources, an external interrupt and a HDLC interrupt. The HDLC interrupt has two registers associated with it; the HDLC Interrupt Register which is used to determine the source of the interrupt, and the HDLC Interrupt Enable Register that enables the source of the interrupt.

The state of the external interrupts can be read through a register allowing the interrupt pins to be used as inputs. The interrupt pins INT0 and INT1 can be either negative edge, positive edge or level triggered. The INT2 pin is always edge triggered.

Two buffered clock outputs have been added to support peripheral functions such as UARTs, modems and other clocked devices. The main internal processor clock frequency can be divided by 2 for power conservation in functional modes that only require half the clock speed.

Additional internal special function registers are used for firmware control over the HDLC Packetizer, the clocks and the programmable I/O ports.

To accommodate processor peripherals when operating at 22 MHz the processor's timing has been altered somewhat to allow more address setup time for slower peripheral program ROM and memory mapped peripherals. This can offer the system designers an advantage when using higher (22 MHz) oscillator frequencies.

For low power applications the 73M2910 operates from 3 to 5 volts at 22 MHz and supports two power conservation modes: Idle and Power-down. In the Power-down state the total current consumption is less than 10 μ A at room temperature.

This device is offered in small form factor 100-lead TQFP packages for PCMCIA applications and 100-lead QFP packages.

DEVELOPER'S NOTE:

The 73M2910 is also available in a 100-pin PGA package for system developers. The PGA package is more convenient and reliable for development emulation systems than the other package styles. Emulation systems for the 73M2910 are available through Signum Systems, 171 E. Thousand Oaks Blvd., #202, Thousand Oaks, CA 91360 (805) 371-4608.

8052 REFERENCE

This Document will describe the features unique to the 73M2910. Please refer to an 8052 Programmer's Guide, Architectural Overview and Hardware Description for details on the instruction set, timers, UART, interrupt control, and memory structure.

REGISTER DESCRIPTION

INTERRUPTS

The core chip provides 8 sources of interrupt; 3 external interrupts, 3 timer interrupts, a serial port interrupt, and an HDLC interrupt. An external interrupt and an HDLC interrupt are unique to the 73M2910. They do not exist in a normal 8052 product. Previously unused bits in the IE and IP registers are now serving functions for these additional interrupt sources. The interrupt vector addresses are as follows:

SOURCE	VECTOR ADDRESS
$\overline{INT0}$ (IE0)	003H
TF0	00BH
$\overline{INT1}$ (IE1)	013H
TF1	01BH
RI + TI	023H
TF2 + EXF2	02BH
$\overline{INT2}$ - ADDED INTERRUPT	033H
HDLC - ADDED INTERRUPT	03BH

4

The external interrupt sources, $\overline{INT}(2:0)$, come from dedicated input pins. The apparent polarity of these pins is individually controlled by bits in a special interrupt direction register, IDIR (address A9). The interrupt pins $\overline{INT1}$ and $\overline{INT0}$ can be either edge or level generated interrupts as indicated by bits 1 and 3 in the TCON register (address 88). Pin $\overline{INT2}$ is always an edge generated interrupt. A flag is set when a falling transition (rising if IDIR bit 2 is set) on this pin is detected. This flag is automatically cleared when the interrupt is processed.

INTERRUPT ENABLE REGISTER (IE) SFR ADDRESS A8

Bit Addressable
Reset State 00h

BIT 7	BIT 6	BIT 5	BIT 4	BIT 3	BIT 2	BIT 1	BIT 0
EA	EX2	ET2	ES	ET1	EX1	ET0	EX0

Note: BIT 6 differs from the 8052. This is a reserved bit in the 8052 and is used as a mask bit for external interrupt 2 in the core implementation. When BIT 6 is set to a 0, external interrupt 2 is disabled.

The mask bit for the HDLC interrupt source is BIT 0 of the HDLC control register.

INTERRUPT PRIORITY REGISTER (IP) SFR ADDRESS B8

Bit Addressable
Reset State 00h

BIT 7	BIT 6	BIT 5	BIT 4	BIT 3	BIT 2	BIT 1	BIT 0
PHDLC	PX2	PT2	PS	PT1	PX1	PT0	PX0

Note: BIT 6 and BIT 7 differ from the 8052. These are reserved bits in the 8052 and are used to determine the priority of external interrupt 2 and the HDLC in the core implementation. When BIT 6 is set to a 1, the interrupt is set to the higher priority level.

SSI 73M2910/2910A

Microcontroller

REGISTER DESCRIPTION (continued)

EXTERNAL INTERRUPT DIRECTION REGISTER (IDIR) SFR ADDRESS 92

Byte Addressable

Reset State 00h

BIT 7	BIT 6	BIT 5	BIT 4	BIT 3	BIT 2	BIT 1	BIT 0
0	0	$\overline{\text{INT2}}$	$\overline{\text{INT1}}$	$\overline{\text{INT0}}$	INTD2	INTD1	INTD0

These bits determine the polarity of the corresponding external signals INT(2:0) which will result in an interrupt and will also allow the user to directly read the logic level at the pads INT(2:0).

BITS(5:3) INT(2:0)

BITS(5:3) are read only bits that reflect the logic value at the corresponding pin. The value is not affected by BITS(2:0).

BITS(2:0) Interrupt Polarity Control

If the bit is set to a 0, a falling edge will trigger the interrupt. If the bit is set to a 1, a rising edge will trigger the interrupt. Also, if the bit is set to a 1, level generated interrupts will occur when the corresponding pin is high and the internal pin signal to the timer controls will be inverted.

Bits 6 and 7 will always be read as 0's.

CLOCK CONTROL REGISTER SFR ADDRESS DA

Byte Addressable

Reset State 00h

BIT 7	BIT 6	BIT 5	BIT 4	BIT 3	BIT 2	BIT 1	BIT 0
Activity	CLK1 CTRL1	MCLK CTRL	CLK2EN	CLK2 CTRL1	CLK2 CTRL0	CLK1EN	CLK1 CTRL0

These bits determine the behavior at the CLK1OUT and CLK2OUT pins and allow the user to divide the main internal processor clock frequency by two for power conservation.

BIT 7

BIT 7 is an activity bit. It is cleared by a read of this register. If the activity bit is set it will prevent the 73M2910 from entering Sleep mode.

BIT 6

When BIT 6 = 1, CLK1OUT will be OSC/1.5 if bit 1 is a 1 and bit 0 is 0.

BIT 5	CLOCK OUT
0	OSC
1	OSC/2

BIT 5 Master Clock Control

When BIT 5 is set to a 1 the internal processor clock is the oscillator frequency divided by 2. If this bit is a 0, the processor clock is the same frequency as the oscillator's.

SSI 73M2910/2910A Microcontroller

BIT 4 Clock 2 Output Enable

BIT 4 enables the clock at the CLOCK 2 output pin if it is set to a 1. The CLOCK 2 pin output is held to a 0, by writing this bit to a 0. This will reduce system power if the clock pin is not used or if a power reduction mode is required.

BIT 3 BIT 2 Clock 2 Output Control

These bits determine the oscillator divisor for the CLOCK 2 output pin. They were designed to provide a 1.8432 MHz clock for an external UART given an oscillator frequency of 11.0592 MHz, 22.1184 MHz, 18.432 MHz, or 13.824 MHz.

BIT 3	BIT 2	CLK 2 OUT	OSC FREQUENCY
0	0	OSC/7.5	13.824 MHz
0	1	OSC/6	11.059 MHz
1	0	OSC/12	22.118 MHz
1	1	OSC/10	18.432 MHz

BIT 1 CLOCK 1 Output Enable

BIT 1 enables the clock at the clock 1 output pin if it is set to a 1. The clock pin output is held to a 0, by writing a 0 to this bit. This will reduce system power if the clock pin is not used or if a power reduction mode is required.

BIT 6 is cleared to a 0 upon a reset.

BIT 0 Clock 1 Output Control

BIT 0 controls the frequency of the clock 1 output pin. The clock output is either the oscillator's output signal divided by two or a buffered oscillator output signal

POWER SAVING MODES

Low Power Modes

The SSI 73M2910 supports two power conservation modes, which are controlled by the PCON.1 and PCON.0 control bits of the PCON register.

If PCON.0 is set, the SSI 73M2910 will go into a power saving mode where the oscillator is running, clocks are supplied to the UART, timers, HDLC, and interrupt blocks, but no clocks are supplied to the CPU. Instruction processing and activity on the address and data ports is halted. Normal operation is resumed when an unmasked interrupt is requested or when a reset occurs.

If PCON.1 is set, the SSI 73M2910 goes into its lowest power mode where the oscillator is halted. The total current consumption in this state should be less than 10 μ A. The SSI 73M2910 will start its oscillator and begin to return to normal operation when either a reset occurs, when a falling (rising if corresponding direction bit is set) edge of an unmasked external interrupt from pins $\overline{INT}(2:0)$ is detected, or when the $USR5(1:0)$ pins change to a state according to the USR 5 port register. Edges used in wakeup modes are not filtered in the SSI 73M2910, so the user must be cautious of noise or small glitches inadvertently waking up the chip. From the time the edge that results in the wake up occurs, to the point at which an instruction is executed, depends on the oscillator start-up time. Three good oscillator pulses must be detected before the main internal clocks are generated.

During Power Down mode, both the ALE and \overline{PSEN} pins are pulled high since these signals often provide the output enable and chip enable for the ROM (active low). This ensures that the external components are in their lowest power state.

SSI 73M2910/2910A

Microcontroller

REGISTER DESCRIPTION (continued)

USER PROGRAMMABLE I/O

Port Control USR1, USR2, USR3, USR4, USR5

The core chip provides 32 user I/O pins. Each pin is programmed separately as either an input or as an output by a bit in a direction register. If the bit in the direction register is set to a 1, the I/O control will treat the corresponding pin as an input. If it is a 0, the pin will be treated as an output whose value is determined by the port data register. The USR1 and USR2 port registers are accessed through the internal SFR bus. The USR3 and USR4 ports are accessed through the external memory bus by a MOVX instruction. The USR4 port provides the user with an automatic chip select function if selected by the user. If the user does not require some (or any) of the chip select pin options, he may program the USR4 port pins to operate in the same way as USR3 port pins.

The USR DATA register contents determine pin values if chosen as an output. When reading from the DATA register's SFR address, the pin logic values are returned as data except when the port address is the destination address for a read-modify-write instruction. In this case, the latched register values are returned as data. When reading data from a DATA register that is mapped in the external memory space, the pin values are always returned as data.

The USR5 register allows for 2 additional input pins. In normal operation these pins can be used as general purpose inputs. In Power Down mode, the user can program either rising or falling transitions or logical combinations of these pins to wake up the chip.

USER 1 PORT

USR1 DATA SFR Address 90

Bit Addressable

Reset State 00h

BIT 7	BIT 6	BIT 5	BIT 4	BIT 3	BIT 2	BIT 1	BIT 0
USR1 7	USR1 6	USR1 5	USR1 4	USR1 3	USR1 2	USR1 1	USR1 0

Bits in this register will be asserted on the USR1(7:0) pins if the corresponding direction register bit is a 0. Reading this SFR's address will return data reflecting the values of pins USR1(7:0) except when address 90h is the destination address for a read-modify-write instruction. In this case, the latched register values are returned as data.

USR1 port signals are also used as timer controls. In applications where the external signals are required for timer count modes, the corresponding port pin should be configured as an input.

USR1 BIT0 = TIMER 0 T0 PIN
USR1 BIT1 = TIMER 1 T1 PIN
USR1 BIT2 = TIMER 2 T2EX PIN
USR1 BIT3 = TIMER 2 T2 PIN

USR1 Port Direction (DIR1) SFR Address 91

Byte Addressable

Reset State FFh

BIT 7	BIT 6	BIT 5	BIT 4	BIT 3	BIT 2	BIT 1	BIT 0
DIR1 7	DIR1 6	DIR1 5	DIR1 4	DIR1 3	DIR1 2	DIR1 1	DIR1 0

This register is used to designate the USR1 pins as either inputs or outputs. If the register bit is reset to a 0, the corresponding USR1 pin is programmed as an output that will be driven by the corresponding USR1 DATA register bit. If the register bit is a 1, the corresponding pin will be treated as an input.

After a reset, the USR1 pins will present a high impedance output state and the input values will not be driven from the pin, but will be driven to a 1 internally. The pins will assume normal I/O operation once the processor has written the port direction register. This feature will ensure a low current state at reset (you don't want to drive out against external inputs, and you don't want floating inputs).

USER2 PORT

USR2 Port Data SFR Address D8

Bit Addressable

Reset State 00h

BIT 7	BIT 6	BIT 5	BIT 4	BIT 3	BIT 2	BIT 1	BIT 0
USR2 7	USR2 6	USR2 5	USR2 4	USR2 3	USR2 2	USR2 1	USR2 0

Bits in this register will be asserted on the USR2(7:0) pins if the corresponding direction register bit is a 0. Reading this SFR's address will return data reflecting the values of pins USR2(7:0) except when address D8h is the destination address for a read-modify-write instruction. In this case, the latched register values are returned as data.

USR2 Port Direction (DIR2) SFR Address D9

Byte Addressable

Reset State FFh

BIT 7	BIT 6	BIT 5	BIT 4	BIT 3	BIT 2	BIT 1	BIT 0
DIR2 7	DIR2 6	DIR2 5	DIR2 4	DIR2 3	DIR2 2	DIR2 1	DIR2 0

This register is used to designate the USR2 pins as either inputs or outputs. If the register bit is reset to a 0, the corresponding USR2 pin is programmed as an output that will be driven by the corresponding USR2 I/O DATA register bit. If the register bit is a 1, the corresponding pin will be treated as an input.

After a reset, the USR2 pins will present a high impedance output state and the input values will not be driven from the pin, but will be driven to a 1 internally. The pins will assume normal I/O operation once the processor has written the port direction register. This feature will ensure a low current state at reset (you don't want to drive out against external inputs, and you don't want floating inputs).

USR3 Port Data External address 0000

Byte Addressable

Reset State 00h

BIT 7	BIT 6	BIT 5	BIT 4	BIT 3	BIT 2	BIT 1	BIT 0
USR3 7	USR3 6	USR3 5	USR3 4	USR3 3	USR3 2	USR3 1	USR3 0

Bits in this register will be asserted on the USR3(7:0) pins if the corresponding direction register bit is a 0. Reading this SFR's address will return data reflecting the values of pins USR3(7:0).

If the bank select feature is chosen, USR3 PIN7 acts as address bit 17 and USR3 data bit 7 is ignored.

SSI 73M2910/2910A

Microcontroller

REGISTER DESCRIPTION (continued)

USR3 I/O Port Direction (DIR3) External Address 0001

Byte Addressable

Reset State FFh

BIT 7	BIT 6	BIT 5	BIT 4	BIT 3	BIT 2	BIT 1	BIT 0
DIR3 7	DIR3 6	DIR3 5	DIR3 4	DIR3 3	DIR3 2	DIR3 1	DIR3 0

This register is used to designate the USR3 pins as either inputs or outputs. If the register bit is reset to a 0, the corresponding USR3 pin is programmed as an output that will be driven by the corresponding USR3 DATA register bit. If the register bit is a 1, the corresponding pin will be treated as an input.

After a reset, the USR3 pins will present a high impedance output state and the input values will not be driven from the pin, but will be driven to a 1 internally. The pins will assume normal I/O operation once the processor has written the USR3 port direction register. This feature will ensure a low current state at reset (you don't want to drive out against external inputs, and you don't want floating inputs).

If the bank select feature is chosen, USR3 PIN7 is forced to be an output.

Bank Select (BNKSEL) External Address 0002

Byte Addressable

Reset State 00h

BIT 7	BIT 6	BIT 5	BIT 4	BIT 3	BIT 2	BIT 1	BIT 0
B7	B6	B5	B4	B3	BSEN	BS1	BS0

This register is used to accommodate systems where more than 64 Kbytes (up to 128 Kbytes) of program memory are required. USR3 PIN 7 acts as an address pin, A16, if BSEN is set to a 1 and if the processor is fetching an instruction and not data memory. If BSEN is set to a 1, A15 is also modified during instruction fetches as shown. If BSEN is a 0, no alterations to address bit A15 are made, and USR3 PIN 7 is a function of USER3 bit 7 and DIR3 bit 7.

Bits (7-3) are general purpose read/write register bits.

A15 is the value of the 16th address bit as it appears at pin A15.

A15' is the address from port 2 internal logic, the value that will appear as the most significant address bit if no bank select feature is chosen.

A16 is the value of the 17th and MSB of the instruction address seen at the USR3 7 port pin, if the bank select feature is selected. If the bank select feature is not selected, USR3 7 acts as a normal USR3 I/O port pin.

SSI 73M2910/2910A Microcontroller

BSEN	BS1	BS0	A15'	A15	A16	ADDRESS
0	*	*	0	0	USR37	0K - 32K
0	*	*	1	1	USR37	32K - 64K
1	0	0	0	0	0	0K - 32K
1	0	0	1	1	0	32K - 64K
1	0	1	0	0	0	0K - 32K
1	0	1	1	0	1	64K - 96K
1	1	0	0	0	0	0K - 32K
1	1	0	1	1	1	96K - 128K
1	1	1	0	0	0	0K - 32K
1	1	1	1	0	1	64K - 96K

* = Don't care.

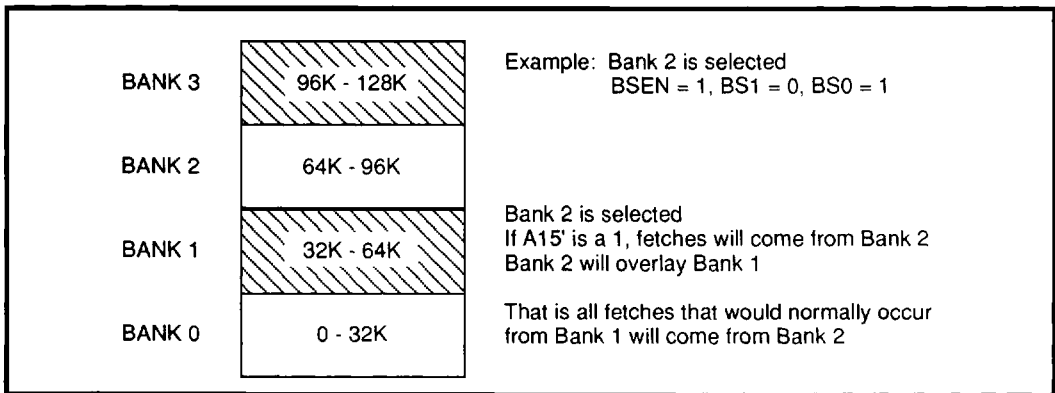

4

FIGURE 8: Bank Select

SSI 73M2910/2910A

Microcontroller

REGISTER DESCRIPTION (continued)

USER4 PORT

USR4 Port Data External Address 0003

Byte Addressable
Reset State 00h

BIT 7	BIT 6	BIT 5	BIT 4	BIT 3	BIT 2	BIT 1	BIT 0
USR4 7	USR4 6	USR4 5	USR4 4	USR4 3	USR4 2	USR4 1	USR4 0

Bits in this register will be asserted on the USR4(7:0) pins if the corresponding direction register bit is a 0 and if the corresponding bit in the chip select enable register, 0005, is set to a 0. Reading this register will return data reflecting the values of pins USR4(7:0).

USR4 I/O Port Direction (DIR4) External Address 0004

Byte Addressable
Reset State FFh

BIT 7	BIT 6	BIT 5	BIT 4	BIT 3	BIT 2	BIT 1	BIT 0
DIR4 7	DIR4 6	DIR4 5	DIR4 4	DIR4 3	DIR4 2	DIR4	1 DIR4 0

This register is used to designate the USR4 pins as either inputs or outputs. If the register bit is reset to a 0, the corresponding USR4 pin is programmed as an output that will be driven by the corresponding USR4 I/O DATA register bit if the corresponding bit in the chip select enable register, 0005, is set to a 0. If the register bit is a 1, the corresponding pin will be treated as an input only if the corresponding bit in register 0005 is set to a 0.

After a reset, the USR4 pins will act as chip select outputs.

USR4 Port Chip Select Enable (CSEN) External Address 0005

Byte Addressable
Reset State FFh

BIT 7	BIT 6	BIT 5	BIT 4	BIT 3	BIT 2	BIT 1	BIT 0
CSEN 7	CSEN 6	CSEN 5	CSEN 4	CSEN 3	CSEN 2	CSEN 1	CSEN 0

This register is used to designate the USR4 pins as either user programmable I/Os or as chip select (CS0B - CS7B) functions on a pin by pin basis. This feature is designed to help reduce external glue logic for peripheral memory mapped devices. The chip select function is programmed by setting the appropriate bits in the CSEN register. When a chip select pin is enabled by setting the corresponding CSEN bit to a 1, all data and direction information from registers 0003 and 0004 for this bit are ignored and the selected port becomes an output. If the bit is reset to a 0, the pin will be treated as a normal programmable user I/O pin as defined by registers 0003 and 0004.

The chip select pins have a defined memory map. The intent is that the outputs can be wire ORed together for a flexible selection of peripheral chip selects. All chip selects will be disabled (forced to a logic 1. It is assumed that all chip selects are active low) after the read or write is completed, and the appropriate chip select will be enabled as the next new external addresses is asserted. After a reset, the CSB pull-up devices are all enabled, that is, all chip select outputs are high. Users must account for this if these pins are intended to be general purpose I/Os.

SSI 73M2910/2910A Microcontroller

The chip selects partition a 64K memory space as follows:

CHIP SELECT PIN	ADDRESS	# BYTES
RESERVED FOR INTERNAL USE	0000H - 00FFH	256
CS0 (USR4.0)	0100H - 01FFH	256
CS1 (USR4.1)	0200H - 03FFH	512
CS2 (USR 4.2)	0400H - 07FFH	1K
CS3 (USR 4.3)	0800H - 0FFFH	2K
CS4 (USR 4.4)	1000H - 1FFFH	4K
CS5 (USR 4.5)	2000H - 3FFFH	8K
CS6 (USR 4.6)	4000H - 7FFFH	16K
CS7 (USR 4.7)	8000H - FFFFH	32K

Note: You can't read from external addresses 0000H-00FFH. These are reserved for SSI 73M2910 internally defined registers

USER5 PORT

USR5 Port Register External Address 0006

Byte Addressable

Reset State 60h

BIT 7	BIT 6	BIT 5	BIT 4	BIT 3	BIT 2	BIT 1	BIT 0
USR5EN	USR50	USR51	POL50	POL51	ACTE0	ACTE1	AND01

This register allows user programmable wakeup capability. If this is not required, this register can be used to read external signals at the USR51 and USR50 pins.

Bit 7 USR5 Input Port Enable

Bit 7 is used to enable the USR51 and USR50 input circuitry. If this bit is a 0, the USR5 pad circuitry is driven to a known level internally and any signal level at the chip pin is ignored. When set to a 1 the pad circuitry is enabled and the values of these pins are reflected in BITS 6 and 7. If these pins are not connected at the board level, this bit should remain at a 0 to keep the pad circuitry from drawing unnecessary current.

The USR5 register can be programmed such that a transition (bit 4 determines rising or falling) of USR50, a transition (bit 3 determines rising or falling) of USR51, or the logical combination of USR50(B) (bit 4 determines high or low level) AND USR51(B) (bit 3 determines high or low level) can wakeup the processor from its Power Down mode.

BIT 6 USR50

BIT 6 reflects the value of chip pin USR50 if the USR5EN bit is set to a 1.

BIT 5 USR50

BIT 5 reflects the value of chip pin USR51 if the USR5EN bit is set to a 1.

SSI 73M2910/2910A

Microcontroller

REGISTER DESCRIPTION (continued)

BIT 4 USR50 Polarity

BIT 4 determines which edge or level is used in the wakeup detection circuit. A low level selects a rising transition and the true pin value of USR50 to the wakeup combinatorial circuit. When this bit is set to a 1, a falling transition and complemented USR50 value is presented to the wakeup combinatorial circuit.

BIT 3 USR51 Polarity

BIT 3 determines which edge or level is used in the wakeup detection circuit. A low level selects a rising transition and the true pin value of USR51 to the wakeup combinatorial circuit. When this bit is set to a 1, a falling transition and complemented USR51 value is presented to the wakeup combinatorial circuit.

BIT 2 USR50 Edge Activity Enabled

When BIT 2 is set to a 1, a transition of USR50 of the appropriate level as dictated by BIT 4, will wake up the processor. If this bit is reset to a 0, edge activity on this pin is ignored.

BIT 1 USR51 Edge Activity Enabled

When BIT 1 is set to a 1, a transition of USR50 of the appropriate level as dictated by BIT 3, will wake up the processor. If this bit is reset to a 0, edge activity on this pin is ignored.

BIT 0 Combinatorial and of USR50 and USR51 Level Enabled

When BIT 0 is set to a 1, the value USR50 or its complimented value as dictated by BIT 3, ANDed with the value USR51 or its complimented value as dictated by BIT 2, will wake up the processor. If this bit is reset to a 0, the levels of USR50 and USR51 are ignored.

USR50	USR51	BIT 4	BIT 3	BIT 2	BIT 1	BIT 0	WAKEUP
*	*	*	*	0	0	0	NO
0-1	*	0	*	1	*	*	YES
1-0	*	1	*	1	*	*	YES
*	0-1	*	0	*	1	*	YES
*	1-0	*	1	*	1	*	YES
0	0	1	1	*	*	1	YES
1	0	0	1	*	*	1	YES
0	1	1	0	*	*	1	YES
1	1	0	0	*	*	1	YES

* = Don't care.

SSI 73M2910/2910A Microcontroller

HDLC CONTROL REGISTER 0

HDLC Control Register 0 (HDLC0) SFR Address C0

Bit Addressable Reset State 00XX 0000 b

Bits 5 and 4 are read only bits

BIT 7	BIT 6	BIT 5	BIT 4	BIT 3	BIT 2	BIT 1	BIT 0
WRXD	WPTXD	TXD R	PRXD R	RXD CTRL1	RXD CTRL0	PTX CTRL1	PTX CTRL0

This register controls the basic set-up of the DTE and modem pins RXD, TXD, PRXD, and PTXD.

BIT 7 WRXD

BIT 7 allows the processor to write directly to the SSI 73M2910 RXD output pin. The value of BIT 7 will appear at the PTXD pin only if BIT 1 is a 1 and BIT 0 is a 0.

BIT 6 WPTXD

BIT 6 allows the processor to write directly to the SSI 73M2910 PTXD output pin. The value of BIT 6 will appear at the PTXD pin only if BIT 1 is a 1 and BIT 0 is a 0.

BIT 5 TXD

BIT 5 is a read only bit that reflects the value at the SSI 73M2910 TXD input pin.

BIT 4 PRXD

BIT 4 is a read only bit that reflects the value at the SSI 73M2910 PRXD input pin.

BIT 3 BIT 2 RXD Control

BIT 3 and BIT2 control the source of the SSI 73M2910 RXD output pin. This output goes to the DTE's RS232 interface. The source of this signal can be the core's UART TXD output, the PRXD output from a modem peripheral (clear channel), the DTE's TXD(echo), or the value written into bit 7 of this register.

BIT 3	BIT 2	RXD OUTPUT
0	0	UART TXD OUTPUT
0	1	PRXD BUFFERED (CLEAR CHANNEL)
1	0	TXD BUFFERED (ECHO)
1	1	WRXD (BIT 7)

BIT 1 BIT 0 PTXD Control

BIT 1 and BIT0 control the source of the SSI 73M2910 PTXD output pin. This output goes to the modem's TX data input. The source of this signal can be the core's HDLC TX output, the DTE's TXD output (clear channel), or the value written into bit 6 of this register.

BIT 1	BIT 0	PTXD Output
0	0	HDLC TX Output
0	1	TXD Buffered (Clear Channel)
1	0	WPTXD (BIT 6)
1	1	0

SSI 73M2910/2910A

Microcontroller

REGISTER DESCRIPTION (continued)

HDLC CONTROL REGISTER 1

HDLC Control Register 1 (HDLC1) SFR Address C1

Byte Addressable

Reset State 00h

BIT 7	BIT 6	BIT 5	BIT 4	BIT 3	BIT 2	BIT 1	BIT 0
HDLC RST	CCITT	CRC PRE	RXCRC 32	RXCRC 16	TXCRC CTRL	ZERO ID	HDLC EN

This register controls the basic set-up of the HDLC block. This register will be written during initialization and not during normal message processing.

BIT 7 HDLC Software Reset

When BIT 7 is a 1, the HDLC circuit is reset and held in a low power state and no interrupts from the HDLC circuitry will be generated. When a 0 is written to this bit, the HDLC circuit will behave according to its control bits. BIT 7 and the power on reset signal are OR'ed together to form a reset signal for the HDLC block.

BIT 7 is cleared to a 0 upon a power up reset.

BIT 6 CRC Type Control

BIT 6 selects the CRC algorithm used in the 16 bit CRC calculation. There are two types of 16-bit CRCs commonly used, CRC16 and the CCITT 16-bit CRC. If this bit is set to a 1, the CCITT type is selected.

BIT 6 is cleared to a 0 upon a reset.

BIT 5 CRC Preset Value

BIT 5 selects the reset value for the CRC generator and receiver. If this bit is set to a 1, the CRC generator and receiver are initialized to ones and if this bit is reset to a 0, they are initialized to 0s. This bit should be set to a 1 for most CCITT polynomials.

BIT 5 is cleared to a 0 upon a reset.

BIT 4 BIT 3 RX CRC Control

BIT 4 and BIT 3 determine the type of CRC remainder that will be checked at the end of a received frame. There is a 16-bit CRC, and a 32-bit CRC that the HDLC block can support. If both BIT 4 and BIT 3 are reset, bits 7 and 6 of the HDLC STATUS register will be held to a 0. If both BIT 4 and BIT 3 are 1s, a special CRC search mode is enabled where both bits 7 and 6 of the HDLC status register are enabled. This mode is used during a connection to determine which CRC is used by the initiating modem. If the 16-bit CRC remainder is not matched at the end of the received frame, then BIT 6 of the HDLC STATUS register is set. If the 32-bit CRC remainder is not matched at the end of the received frame, then BIT 7 of the HDLCSTATUS register is set. Once the correct CRC type is established during a connection, either BIT 4 or BIT 3 should be set to a 1 enabling the appropriate INVALID CRC status bit.

BIT 4	BIT 3	CRC TYPE
0	0	NO CRC Check
0	1	Enable CRC16 Status
1	0	Enable CRC32 Status
1	1	Enable CRC16 Status and CRC32 Status

BIT 2 TXCRC Control

BIT 2 controls the CRC type to be transmitted. If BIT 2 is reset to a 0, a 16-bit CRC will be transmitted with the SEND CRC command. If BIT 2 is set to a 1, a 32 bit CRC will be transmitted.

BIT 1 Zero Insert/Delete Control

When BIT 1 is set to a 1, a 0 will be transmitted if either the SEND DATA or SENDCRC bits of the HDLCTX CONTROL are set after five consecutive 1s have been transmitted. Also, when this bit is set, a 0 will be removed from the received data stream if it immediately follows a pattern of a 0 followed by five consecutive ones. If BIT 1 is reset to a 0, no 0s will be inserted during transmission, and no 0s will be deleted during reception.

BIT 1 is cleared to a 0 upon a reset.

BIT 0 HDLC Interrupt Enable

When BIT 0 is reset to a 0, the HDLC will be prevented from generating an interrupt. The status bits that indicate the source of the interrupt can still be set allowing the HDLC block to be serviced in a polled mode.

BIT 0 is cleared to a 0 upon reset.

HDLC TX Control Resister (HTXC) SFR Address C2

Byte Addressable

Reset State 00h

BIT 7	BIT 6	BIT 5	BIT 4	BIT 3	BIT 2	BIT 1	BIT 0
0	0	0	DIV16 CLK	SEND ABORT	SEND CRC	SEND DATA	SEND FLAG

This register is used to control the source of data that appears on the PTXD pin. Bits are shifted out on every rising edge of the PTXCLK pin input. If no control bits are set, or more than 1 TX CONTROLbit is set, the PTXD pin will go to a binary 1.

BIT 7 - BIT 5 Always 0

BIT 4 16X Clock Select

Under normal synchronous operation, the PTXCLK and PRXCLK are used to receive and transmit data PRXD and PTXD. The clock rate is equal to the data rate. In asynchronous modes, a clock 16 times the bit rate is provided at PTXCLK and PRXCLK.

When BIT 4 is set to a 1 for asynchronous operation, the clocks at the PTXCLK and PRXCLK pins are divided by 16 to provide transmit and receive shift clocks. An internal clock for sampling incoming PRXD data is synchronized by detecting any falling edge on the PRXD data pin. The rising edge of this internal clock, which used to sample incoming data, is delayed from the falling data edge by 8 PRXCLK periods and will continue at this phase and at a PRXCLK/16 frequency until another falling PRXD edge is detected.

If BIT 4 is reset to a 0, the rising edge of PTXCLK is used to sample the data at PRXD, and the falling edge of PTXCLK is used to shift new data onto PTXD.

BIT 3 is cleared to a 1 upon a reset.

SSI 73M2910/2910A

Microcontroller

REGISTER DESCRIPTION (continued)

BIT 3 Abort

When BIT 3 is set to a 1, a series of consecutive ones will immediately be transmitted through the PTXD pin on every falling edge of PTXCLK. The message will have been aborted after 2 TX ready interrupts are received. No zeros will be inserted during the abort transmission.

BIT 3 is cleared to a 1 upon a reset.

BIT 2 Send CRC

When BIT 2 is set, the bytes in the TX CRC generator will be inverted and serially transmitted to the PTXD output on the falling edge on PTXCLK as soon as the present data byte transmission is completed. If BIT 1 of the HDLC control register is a 0, a 0 will be inserted into the CRC data stream after five consecutive ones are transmitted. As soon as the last bit of the CRC is sent, a series of Flags will be automatically sent until another TX control bit is set. No TX Ready interrupts will be generated during the transmission of the CRC bytes. A TX Ready interrupt will be generated as the first bit of each Flag byte is transmitted indicating that the CRC transmission has been completed. This should be cleared by a dummy write to the TX DATA register.

BIT 2 will be cleared to a 0 upon a reset.

BIT 1 Send Data

When BIT 1 is set, the data in the TX data register will be serially transmitted through the PTXD pin on every falling edge of PTXCLK, LSB first. If BIT 1 of the HDLC control register is a 0, a 0 will be inserted into the data stream after five consecutive 1s are transmitted. After all eight data register bits have been sent, the HDLC will continue to send data by loading the parallel serial transmit register with new transmit register data, unless either a TX underrun is detected or one of the other TX control bits has been set. This bit will be cleared by the HDLC circuitry as soon as a TX underrun is detected. A TXRDY interrupt will be generated at as the first data of each data byte is transmitted. BIT 1 will be cleared to a 0 upon a reset.

BIT 0 Send Flag

When BIT 0 is set, a pattern of 7E will be transmitted to the PTXD output as soon as either the next data byte or CRC has completed transmission. No 0s will be inserted during the flag transmission. When BIT 0 is reset back to a 0, the HDLC circuitry will complete the flag byte in progress and then transmit according to bits in the TX CONTROL register. TX Ready interrupts will be generated as each byte of flag transmission is initiated.

BIT 0 will be cleared to a 0 upon a reset.

HDLC STATUS REGISTER

HDLC Status Register (HSTAT) SFR Address C3

Byte Addressable
Reset state 00h
Read only register

If any of the HDLC status bits are set, BIT 1 of the HDLC INTERRUPT register (NEW STATUS) will be set if the corresponding bit in the HDLC INTERRUPT ENABLE register is set.

BIT 7	BIT 6	BIT 5	BIT 4	BIT 3	BIT 2	BIT 1	BIT 0
INVAL CRC32	INVAL CRC16	TX UNDRN	RX OVRN	INVAL FLAG	ABORT DET	IDLE DET	FLAG DET

BIT 7 Invalid CRC32

BIT 7 will be set if the CRC search mode or the 32-bit CRC is enabled by the HDLC control register and an incorrect remainder for the 32-bit CRC is detected at the last received byte prior to receiving a flag.

BIT 7 will be cleared upon a reset and is cleared by a read of the HDLCSTAT register.

BIT 6 Invalid CRC16

BIT 6 will be set if the CRC search mode or the 16-bit CRC is enabled by the HDLC CONTROL register and an incorrect remainder for the 16-bit CRC is detected at the last received byte prior to receiving a flag.

BIT 6 will be cleared upon a reset and is cleared by a read of the HDLC STAT register.

BIT 5 TX Underrun

When BIT 5 is set, a transmit underrun condition has been detected. This is a condition where the HDLC has finished transmitting a message byte, but no new data has been loaded into the TX DATA register, and no other transmit control bit has been set. This bit will be set only if the SEND DATA bit, BIT 1 of the TXCONTROL register is set. The transmit data is double buffered since the TX data register is downloaded into a TX serial register when the HDLC begins to transmit a new data byte. At the time of loading the TX serial register, a TX READY interrupt is generated. This interrupt must be serviced by either loading a new data byte (the next data byte to be transmitted) into the TX data register, or by setting another TX control bit, before the current data byte has completed transmission (at which point another TX READY interrupt would be generated). If a TX UNDERRUN is detected, the HDLC will abort the current transmission by sending continuous ones and will reset the SEND DATA control bit in the TX CONTROL register.

BIT 5 will be cleared upon a reset and is cleared by a read of the HDLCSTAT register.

BIT 4 RX Overrun

When BIT 4 is set, a receive overrun condition has been detected. This is a condition where the HDLC has received a new byte, but the last received data byte has not yet been read from the RX data register. As soon as a new data byte has been received in an eight bit serial register, it is loaded into the RX data register and a NEW RX DATA interrupt is generated. If this interrupt is not serviced by reading the RX data register during the time another new data byte is received, the RX OVERRUN status bit will be set. The new received data will not overwrite the older unread data.

BIT 4 will be cleared upon a reset and is cleared by a read of the HDLCSTAT register.

BIT 3 Invalid Flag

When BIT 3 is set, an invalid flag has been detected. This is a condition where a 7E pattern with no inserted 0s is detected, and this pattern did not originate on a byte boundary. Note, two consecutive flags may share a 0, so that the second (or subsequent) flag may not appear to be on a byte boundary. This condition does not result in an invalid flag indication.

BIT 3 will be cleared upon a reset and is cleared by a read of the HDLC STAT register.

BIT 2 Abort Detect

When BIT 2 is set, an abort condition has been detected. This is a condition where seven consecutive ones, with no inserted zeros, are received after an active state. BIT 2 will be cleared upon a reset and is cleared by a read of the HDLC STAT register.

SSI 73M2910/2910A

Microcontroller

REGISTER DESCRIPTION (continued)

BIT 1 Idle Detect

When BIT 1 is set, the first indication of an idle state is detected. An idle state is declared when 15 consecutive ones, with no inserted zeros, are received after an active state.

BIT 1 will be cleared upon a reset and is cleared by a read of the HDLC STAT register.

BIT 0 Flag Detect

When BIT 0 is set, the HDLC has received a 7E pattern with no inserted 0's. BIT 0 will be cleared upon a reset and is cleared by a read of the HDLCSTAT register.

HDLC INTERRUPT ENABLE REGISTER

HDLC Interrupt Enable Register (HIE) SFR Address C4

Byte Addressable

Reset state 00h

If the bit is set, the corresponding interrupt source is enabled.

BIT 7	BIT 6	BIT 5	BIT 4	BIT 3	BIT 2	BIT 1	BIT 0
TX RDY IE	RX RDY IE	TX RDY EN	RX RDY EN	INVAL FLG IE	ABORT IE	IDLE IE	FLAG IE

BIT 7 Transmitter Ready Interrupt Enable

When BIT 7 is set, an HDLC interrupt will be generated if BIT 0 (TX RDY) of the HDLC INTERRUPT register is also set. If BIT 7 is reset to a 0, no HDLC interrupt indication will be given as TX RDY is set. This interrupt enable allows the TX RDY to be a polled bit. Note that BIT 5 of this register is a pre-mask to the TX RDY bit, that is, it will prevent the TX RDY bit from ever being set.

BIT 7 will be cleared upon a reset.

BIT 6 Receiver Ready Interrupt Enable

When BIT 6 is set, an HDLC interrupt will be generated if BIT 1 (RXRDY) of the HDLC INTERRUPT register is also set. If BIT 6 is reset to a 0, no HDLC interrupt indication will be given as RX RDY is set. This interrupt enable allows the RX RDY to be a polled bit. Note that BIT 4 of this register is a pre-mask to the RX RDY bit, that is, it will prevent the RX RDY bit from ever being set.

BIT 6 will be cleared upon a reset.

BIT 5 Transmit Ready Enable

BIT 5 is used to enable the TX RDY and TX UNDERRUN interrupt sources. When BIT 5 is set, the transmitter ready indication will set BIT 0 of the HDLC interrupt register. The TX RDY indication will go active as the first bit of a message byte is being transmitted, except during CRC transmission. Also, if this bit is set, the TX underrun condition will result in a NEW STATUS interrupt. If BIT 5 is reset to a 0, BIT 0 of the HDLC INTERRUPT register will not be set, and no corresponding HDLC interrupt will be generated. Also, a Tx underrun condition, as indicated by BIT 5 of the HDLC STATUS register, will not result in an HDLC interrupt or in setting the NEW STATUS interrupt bit.

BIT 5 will be cleared upon a reset.

BIT 4 Receiver Ready Enable

BIT 4 is used to enable the RX RDY and RX OVERRUN interrupt sources. When BIT 4 is set, the receiver ready indication will set BIT 1 of the HDLC INTERRUPT register. The RX RDY indication will go active when a data byte (a byte that is not a flag, idle, or an abort pattern) is loaded into the RX DATA register. Also, if this bit is set, the RX overrun condition will result in a NEW STATUS interrupt. If BIT 4 is reset to a 0, BIT 1 of the HDLC INTERRUPT register will not be set, and no corresponding HDLC interrupt will be generated. Also, a Rx overrun condition, as indicated by BIT 4 of the HDLC STATUS register, will not result in a HDLC interrupt or in setting the NEW STATUS interrupt bit.

BIT 4 will be cleared upon a reset.

BIT 3 Invalid Flag Interrupt Enable

When BIT 3 is set, a HDLC interrupt will be generated if BIT 3 (INVALID FLAG) of the HDLC STATUS register is also set. If BIT 3 is reset to a 0, BIT 2 (NEW STATUS) of the HDLC INTERRUPT register will not be set as a result of an invalid flag boundary detection and no HDLC interrupt will be generated.

BIT 3 will be cleared upon a reset.

BIT 2 Abort Detect Interrupt Enable

When BIT 2 is set, a HDLC interrupt will be generated if BIT 2 (ABORT DETECT) of the HDLC STATUS register is also set. If BIT 2 is reset to a 0, BIT 2 (NEW STATUS) of the HDLC INTERRUPT register will not be set as a result of an abort pattern detection and no HDLC interrupt will be generated.

BIT 2 will be cleared upon a reset.

BIT 1 Idle Detect Interrupt Enable

When BIT 1 is set, an HDLC interrupt will be generated if BIT 1 (IDLE DETECT) of the HDLC STATUS register is also set. If BIT 1 is reset to a 0, BIT 2 (NEW STATUS) of the HDLC INTERRUPT register will not be set as a result of an idle pattern detection and no HDLC interrupt will be generated.

BIT 1 will be cleared upon a reset.

BIT 0 Flag Detect Interrupt Enable

When BIT 0 is set, a HDLC interrupt will be generated if BIT 0 (FLAG DETECT) of the HDLC STATUS register is also set. If BIT 0 is reset to a 0, BIT 2 (NEW STATUS) of the HDLC INTERRUPT register will not be set as a result of a flag pattern detection and no HDLC interrupt will be generated.

BIT 0 will be cleared upon a reset.

HDLC INTERRUPT REGISTER

HDLC Interrupt Register (HINT) SFR Address C5

Byte Addressable
Read Only register
Reset State 00h

BIT 7	BIT 6	BIT 5	BIT 4	BIT 3	BIT 2	BIT 1	BIT 0
0	0	0	0	0	NEW STAT	DATA RDY	TX RDY

This register is used to determine the source of HDLC interrupts. If one or more of these register bits are set, the HDLC interrupt will go active if BIT 0 of the HDLC CONTROL register is set to a 1.

SSI 73M2910/2910A

Microcontroller

REGISTER DESCRIPTION (continued)

BIT 2 New Status

When BIT 2 is set, an unmasked HDLC status bit from the HDLC STATUS register is set. BIT 2 will be cleared upon a reset and is cleared by a read of the HDLC STATUS register.

BIT 1 Data Ready

When BIT 1 is set, a new received byte has been loaded into the RX DATA register. Note, received bits that are flag, abort, or idle patterns are not considered data, and will not be loaded into the RX DATA register. All inserted 0s have been removed from this byte. The RX DATA register must be read prior to the completed reception of the next data byte.

BIT 1 will be cleared upon a reset and is cleared by a read of the RX DATA register.

BIT 0 TX READY

BIT 0 is set if any TX control bit is set as the first bit of data, flag or an idle byte is being transmitted. While transmitting the current byte, the HDLC state machines are ready for commands pertaining to the next byte to be transmitted. A new data byte must be loaded into the TX DATA register to clear the TX READY status bit. BIT 0 will be cleared upon a reset and is cleared by writing to the TX DATA register.

RX DATA REGISTER

RX Data Register (RXD) SFR Address C6

Byte Addressable
Reset state XXh
Read Only

BIT 7	BIT 6	BIT 5	BIT 4	BIT 3	BIT 2	BIT 1	BIT 0
RX DAT7	RX DAT6	RX DAT5	RX DAT4	RX DAT3	RX DAT2	RX DAT	RX DAT0

BIT 7 - BIT 0 Received Data Byte

BIT 7 through BIT 0 is the received data byte (LSB is received first) with all inserted 0s removed. A DATA READY interrupt will be generated when a new data byte is received. Reading this register will clear the DATA READY interrupt.

TX DATA REGISTER

TX Data Register (TXD) SFR Address C7

Byte Addressable
Reset state XXh
Write Only

BIT 7	BIT 6	BIT 5	BIT 4	BIT 3	BIT 2	BIT 1	BIT 0
TX DAT7	TX DAT6	TX DAT5	TX DAT4	TX DAT3	TX DAT2	TX DAT1	TX DAT0

BIT 7 - BIT 0 Transmit Data Byte

BIT 7 through BIT 0 will be transmitted at the next byte boundary (LSB first) if the TX CONTROL SEND DATA bit is set. The HDLC will insert all necessary 0s. A TX READY interrupt will be generated when a new data byte can be loaded into the TX DATA register. Writing this register will clear the TX READY interrupt.

SSI 73M2910/2910A Microcontroller

REGISTER	ADDRESS	BIT 7	BIT 6	BIT 5	BIT 4	BIT 3	BIT 2	BIT 1	BIT 0
HDLC CONTROL 0	C0	WRXD	WPTXD	TXD	PRXD	RXD CTRL1	RXD CTRL0	PTXD CTRL1	PTX CTRL0
HDLC CONTROL 1	C1	RESET	CCITT	CRC PRE	RXCRC32	RXCRC16	TXCRC32	ZERO ID	HDLC EN
TX CONTROL	C2	0	0	0	DIV16 CLK	SEND ABORT	SEND CRC	SEND DATA	SEND FLAG
HDLC STATUS	C3	INVAL CRC32	INVAL CRC16	TX UNDERRUN	RX UNDERRUN	INVAL FLAG	ABORT DETECT	IDLE DETECT	FLAG DETECT
HDLC INT ENABLE	C4	TX RDY IE	RX RDY IE	TX RDY EN	RX RDY EN	INVAL FLAG IE	ABORT IE	IDLE IE	FLAG IE
HDLC INT SOURCE	C5	0	0	0	0	0	NEW STATUS	RX READY	TX READY
RX DATA	C6	RXDAT7	RXDAT6	RXDAT5	RXDAT4	RXDAT3	RXDAT2	RXDAT1	RXDAT0
TX DATA	C7	TXDAT7	TXDAT6	TXDAT5	TXDAT4	TXDAT3	TXDAT2	TXDAT1	TXDAT0

FIGURE 9: HDLC SFR Registers

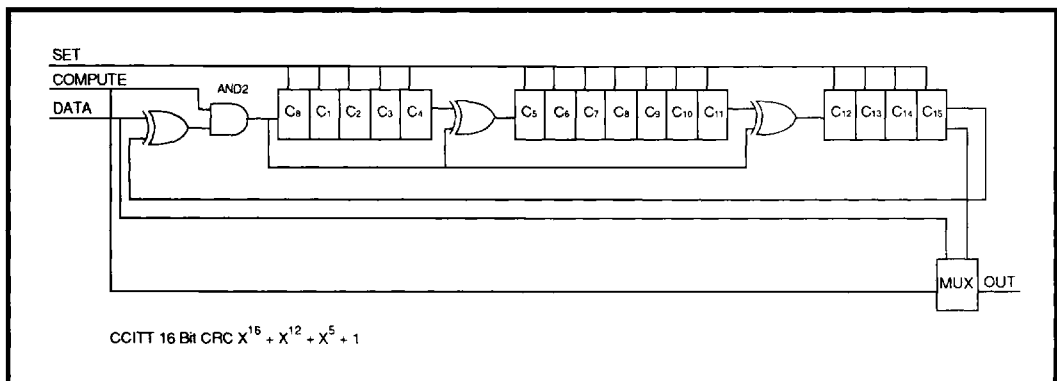

FIGURE 10: CCITT Type

The CRC check field is generated by the transmitter. The computation starts with the first transmitted bit after the opening flag and stops at the last data bit prior to the frame check sequence bytes, and excludes inserted 0s. The CRC generating logic is initialized to all ones. The bits are shifted in and operated on by the generating polynomial, $X^{16} + X^{12} + X^5 + 1$. During CRC transmission, the bytes in the CRC generating logic are inverted and transmitted, high order bit first.

The receiver also initializes its CRC computation logic to all ones after the beginning flag. Its polynomial generator (also $X^{16} + X^{12} + X^5 + 1$) should see the same value as the transmitter's polynomial generator as the last data bit is received. Note the receiver's polynomial generator does not process inserted 0s. After the bytes are received in the frame check sequence, a remainder of 1111 0000 1011 1000 (X^0 through X^{15} , respectively) should be detected in the receiver's polynomial generator. If this is not the case, it is assumed that the preceding frame was in error and an invalid CRC is declared.

SSI 73M2910/2910A Microcontroller

REGISTER DESCRIPTION (continued)

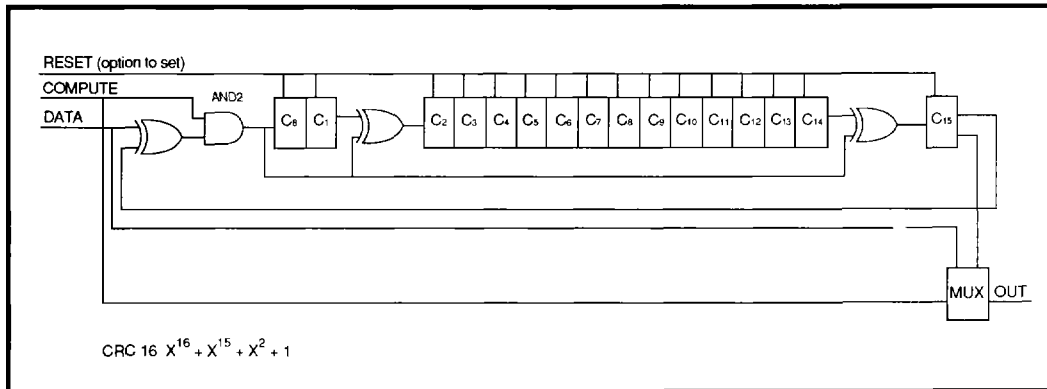

FIGURE 11: CRC 16

The CRC check field is generated by the transmitter. The computation starts with the first transmitted bit after the opening flag and stops at the last data bit prior to the frame check sequence bytes, and excludes inserted 0s. The CRC generating logic is initialized to all 0s. The bits are shifted in and operated on by the generating polynomial, $X^{16} + X^{12} + X^5 + 1$. During CRC transmission, the bytes in the CRC generating logic are transmitted, high order bit first.

The receiver also initializes its CRC computation logic to all ones after the beginning flag. Its polynomial generator (also $X^{16} + X^{12} + X^5 + 1$) should see the same value as the transmitter's polynomial generator as the last data bit is received. Note the receiver's polynomial generator does not process inserted 0s. After the bytes are received in the frame check sequence, a remainder of 1111 0000 1011 1000 should be detected in the receiver's polynomial generator. If this is not the case, it is assumed that the preceding frame was in error and an invalid CRC is declared.

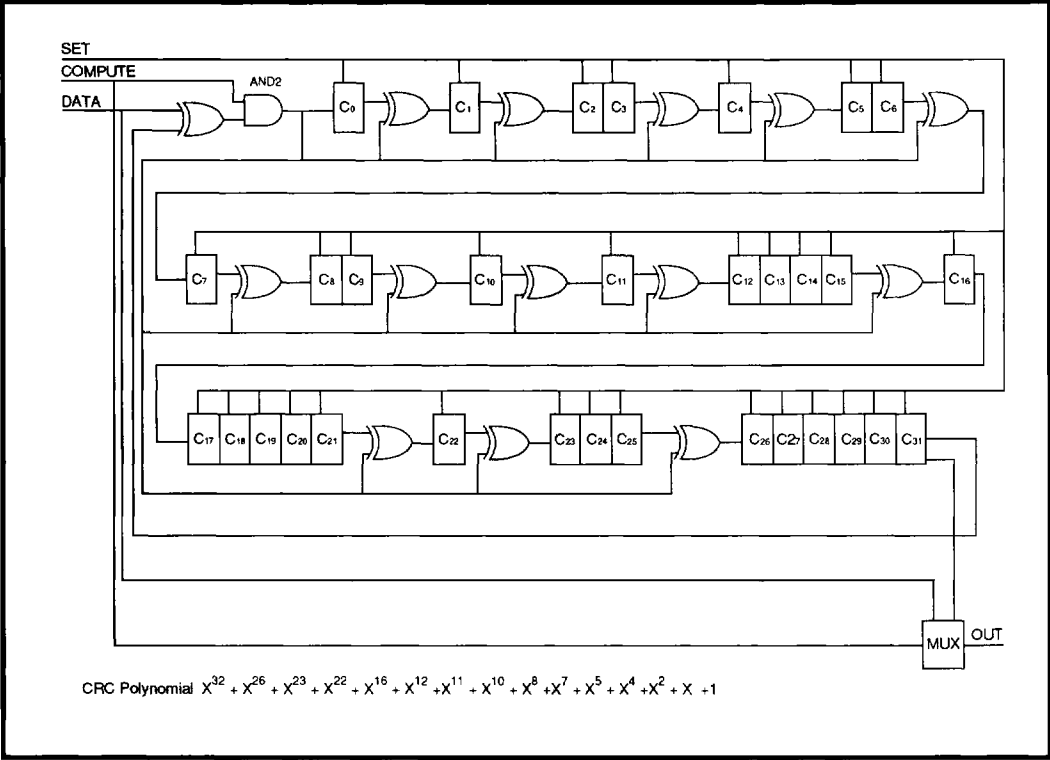

FIGURE 12: 32 Bit CRC

The CRC check field is generated by the transmitter. The computation starts with the first transmitted bit after the opening flag and stops at the last data bit prior to the frame check sequence bytes, and excludes inserted 0s. The CRC generating logic is initialized to all ones. The bits are shifted in and operated on by the generating polynomial, $X^{32} + X^{26} + X^{23} + X^{22} + X^{16} + X^{12} + X^{11} + X^{10} + X^8 + X^7 + X^5 + X^4 + X^2 + X + 1$. During CRC transmission, the bytes in the CRC generating logic are inverted and transmitted, high order bit first. The receiver also initializes its CRC computation logic to all

ones after the beginning flag. Its polynomial generator should see the same value as the transmitter's polynomial generator as the last data bit is received. Note the receiver's polynomial generator does not process inserted 0s. After the bytes are received in the frame check sequence, a remainder of 1101 1110 1011 1011 0010 0000 1110 0011 (X^0) through X^{32} , respectively) should be detected in the receiver's polynomial generator. If this is not the case, it is assumed that the preceding frame was in error and an invalid CRC is declared.

SSI 73M2910/2910A

Microcontroller

PIN DESCRIPTION

NAME	TYPE	DESCRIPTION
PSEN	O	Program store enable. This output occurs only during a fetch to external program memory.
RESET	I	Input which is used to initialize the processor.
VND	GND	Negative digital voltage ground
OSCIN	I	Crystal input for internal oscillator, also input for external source.
OSCOU	O	Crystal oscillator output.
VPD	I	Positive digital voltage (+5V Digital Supply)
CLKOUT1	O	Clock output programmable either OSC/2, OSC/1 or logic 0.
CLKOUT2	O	Clock output 1.8432 MHz clock for an external UART given an oscillator frequency of 11.0592 MHz, 22.1184 MHz, 18.432 MHz, or 13.824 MHz.
TXD	I	Serial input port to 73M2910 from DTE same as RXD UART input.
RXD	O	Serial output port of 73M2910 UART to DTE.
PTXCLK	I	Input clock used to transmit data PTXD.
PTXD	O	HDLC Packetizer TX output. This pin can also be programmed to the DTE's TXD output (clear channel) or the value written into bit 6 of the HDLC control register. Connects to modem device TXD.
PRXCLK	I	Input clock used to receive data PRXD.
PRXD	I	Serial input port (from modem device).
INT(0)-INT(2)	I	External interrupt 0, 1 and 2.
USR1(0) -USR1(7)	I/O	User programmable I/O port.
USR2(0) -USR2(7)	I/O	User programmable I/O port.
USR3(0) -USR3(7)	I/O	User programmable I/O port. If the bank select feature is chosen, USR (7) acts as address bit 17 and USR3 data bit 7 is ignored. Register BNKSEL bit 2 (BSEN) enables bank select, bit 1 (BS1) and bit 0 (BS0) select the appropriate bank.
USR4(0) -USR4(7)	I/O	User programmable I/O port also Chip select enable.
USR5(0) - USR5(1)	I/O	General purpose input port, can also be used for wakeup.
RD	O	Output strobe activated during a bus read. Can be used to enable data onto the bus from an external device. Used as a read strobe to external data memory.
WR	O	Output strobe during a bus write. Used as a write strobe to external data memory.
ALE	O	Address Latch Enable output pulse for latching the low byte of the address during accesses to external memory.
AD(0)-AD(7)	I/O	Data bus lines-I/O for devices that require multiplexed address and data bus.
A(0)-A(15)	O	Address bus lines-output latched address for devices that require separate data and address bus.
NO CONNECTS		No connections, leave open.

SSI 73M2910/2910A Microcontroller

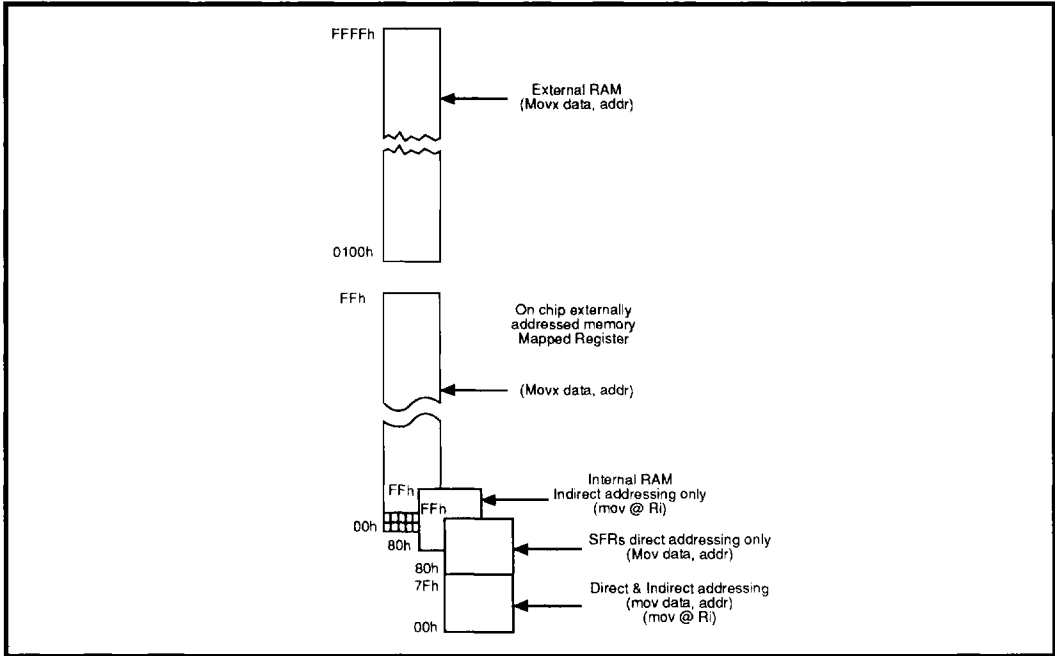

FIGURE 1: Memory Map

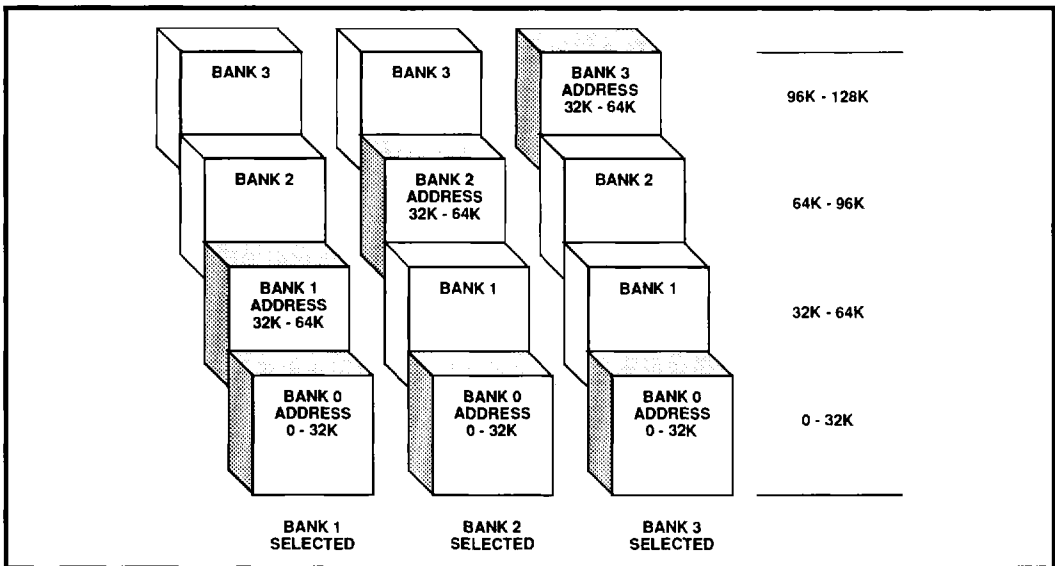

FIGURE 2: 128K of Bank-Selected Program Memory

SSI 73M2910/2910A Microcontroller

ELECTRICAL SPECIFICATIONS

ABSOLUTE MAXIMUM RATINGS

Recommended conditions apply unless otherwise specified.

PARAMETER	RATING
Supply Voltage	-0.5 to +7.0V
Pin Input Voltage	-0.5 to $V_{CC} + 0.5V$
Storage Temperature	-55 to +150°C

RECOMMENDED OPERATING CONDITIONS

Supply Voltage	4.5 to 5.5V
Oscillator Frequency	DC to 33 MHz
Supply Voltage	4.75 to 5.5V
Oscillator Frequency	DC to 44 MHz
Supply Voltage	3.0 to 5.5V
Oscillator Frequency	DC to 22 MHz
Operating Temperature	-40 to +85°C

4

DC CHARACTERISTICS

PARAMETER	CONDITION	MIN	NOM	MAX	UNIT
Input Low Voltage (Except OSCIN, RESET, TEST)	V_{IL}	-0.5		$0.2 V_{CC} - 0.1$	V
Input Low Voltage OSCIN, RESET, TEST	V_{IL}	-0.5		$0.2 V_{CC}$	V
Input High Voltage (Except OSCIN, RESET, TEST)	V_{IH}	$0.5 V_{CC}$		$V_{CC} - 0.5$	V
Input High Voltage OSCIN, RESET, TEST	V_{IH}	$0.7 V_{CC}$		$V_{CC} + 0.5$	V
Output Low Voltage (Except OSCOUT)	V_{OL} $I_{OL} = 3.2 \text{ mA}$			0.45	V
Output Low Voltage OSCOUT	V_{OL} $I_{OL} = 1.5 \text{ mA}$			0.7	V
Output High Voltage (Except OSCOUT)	V_{OH} $I_{OH} = -3.2 \text{ mA}$	$V_{CC} - 0.45$			V
Output High Voltage OSCOUT	V_{OH} $I_{OH} = 1.5 \text{ mA}$	$V_{CC} - 0.7$			V
Input Leakage Current	I_{IL} $V_{SS} < V_{IN} < V_{CC}$			± 10	μA
Maximum Power Supply Normal Operation	I_{DD1} 22MHz 30 pF/pin			40	mA
Maximum Power Supply Idle Mode	I_{DD2} 22 MHz			10	mA

SSI 73M2910/2910A

Microcontroller

ELECTRICAL SPECIFICATIONS (continued)

DC CHARACTERISTICS

PARAMETER	CONDITION	MIN	NOM	MAX	UNIT
Maximum Power Supply Power Down Mode	IDD3			10	μA
Pin Capacitance	CIO @1 MHz			10	pF

AC TIMING

Oscillator Frequency	FOSC	0		22.2	MHz
Oscillator Period	TOSC	45			ns
ALE Pulse Width	TLHLL	2TOSC - 10			ns
Address Valid To ALE low	TAVLL	TOSC			ns
Address Valid ALE low	TLLAX	TOSC - 10			ns
ALE low to $\overline{\text{PSEN}}$ low	TLLPL	TOSC - 10			ns
$\overline{\text{PSEN}}$ Pulse width low	TPLPH	3TOSC - 20			ns
$\overline{\text{PSEN}}$ Low to Valid Inst In	TPLIV			3TOSC - 50	ns
Address to Valid Inst In	TAVIV			5TOSC - 50	ns
Input Instr Hold- $\overline{\text{PSEN}}$ Hi	TPXIX	0			ns
$\overline{\text{PSEN}}$ Instr Float- $\overline{\text{PSEN}}$ Hi	TPXIZ			20+	ns
$\overline{\text{PSEN}}$ Low to Address HIZ	TPLAZ			10	ns
$\overline{\text{RD}}$ Pulse Width	TRLRH	6TOSC - 20			ns
$\overline{\text{WR}}$ Pulse Width	TWLWH	6TOSC - 20			ns
$\overline{\text{RD}}$ Low to Valid Data In	TRLDV			5TOSC - 50	ns
Data Hold After $\overline{\text{RD}}$	TRHDX	0			ns
Data Float After $\overline{\text{RD}}$	TRHDZ			20+	ns
ALE Low to Valid Data In	TLLDV			8TOSC - 50	ns
ALE low to $\overline{\text{RD}}$ or $\overline{\text{WR}}$ low	TLLWL	3TOSC - 20		3TOSC + 20	ns
Data Valid to $\overline{\text{WR}}$ low	TQVWX	TOSC			ns
Data Hold After $\overline{\text{WR}}$ Hi	TWHQX	TOSC - 10			ns
$\overline{\text{RD}}$ low to Address Float	TRLAZ			10	ns

SSI 73M2910/2910A Microcontroller

AC TIMING (continued)

The SSI 73M2910 timing is very similar to the 8051 except in AD(7:0), the multiplexed address data port known as port 0 in the 8051. Its timing has been altered somewhat to allow more address setup time for peripheral program ROM and memory mapped peripherals. This is important at 22 MHz operation. The 8052 has a "dead" cycle of one oscillator period between the time PSEN goes high, indicating that the instruction ROM will release the AD(7:0) bus, to the time the processor will assert address on the AD(7:0) bus. This dead time of one whole oscillator cycle has been shortened to approximately 15 ns after the PSEN (or RD) signal is sensed to be high.

The timing specification for TPXIZ and TRHDZ of a maximum of 20 ns can be violated at the expense of increased operating current. The SSI 73M2910 will begin asserting the AD(7:0) bus approximately 20 ns after PSEN or RD go high. This should be ample time for the control signals in the peripheral device to turn off their pad drivers. If the peripheral device does not release the bus promptly, there will be a short time where there is contention on the AD(7:0) bus between the processor and peripheral. This should not prevent proper operation, but it will increase operating current slightly.

SSI 73M2910/2910A Microcontroller

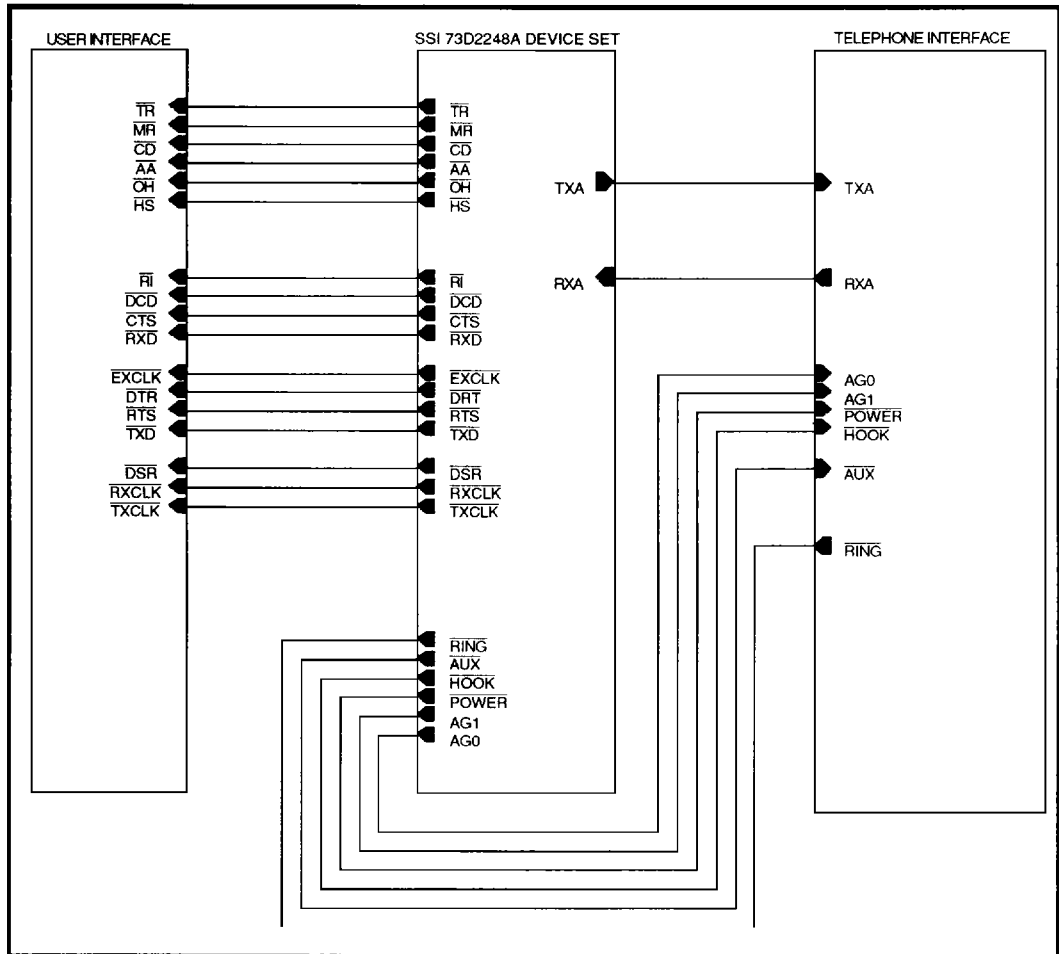

FIGURE 13: Modem Block Diagram

SSI 73M2910/2910A Microcontroller

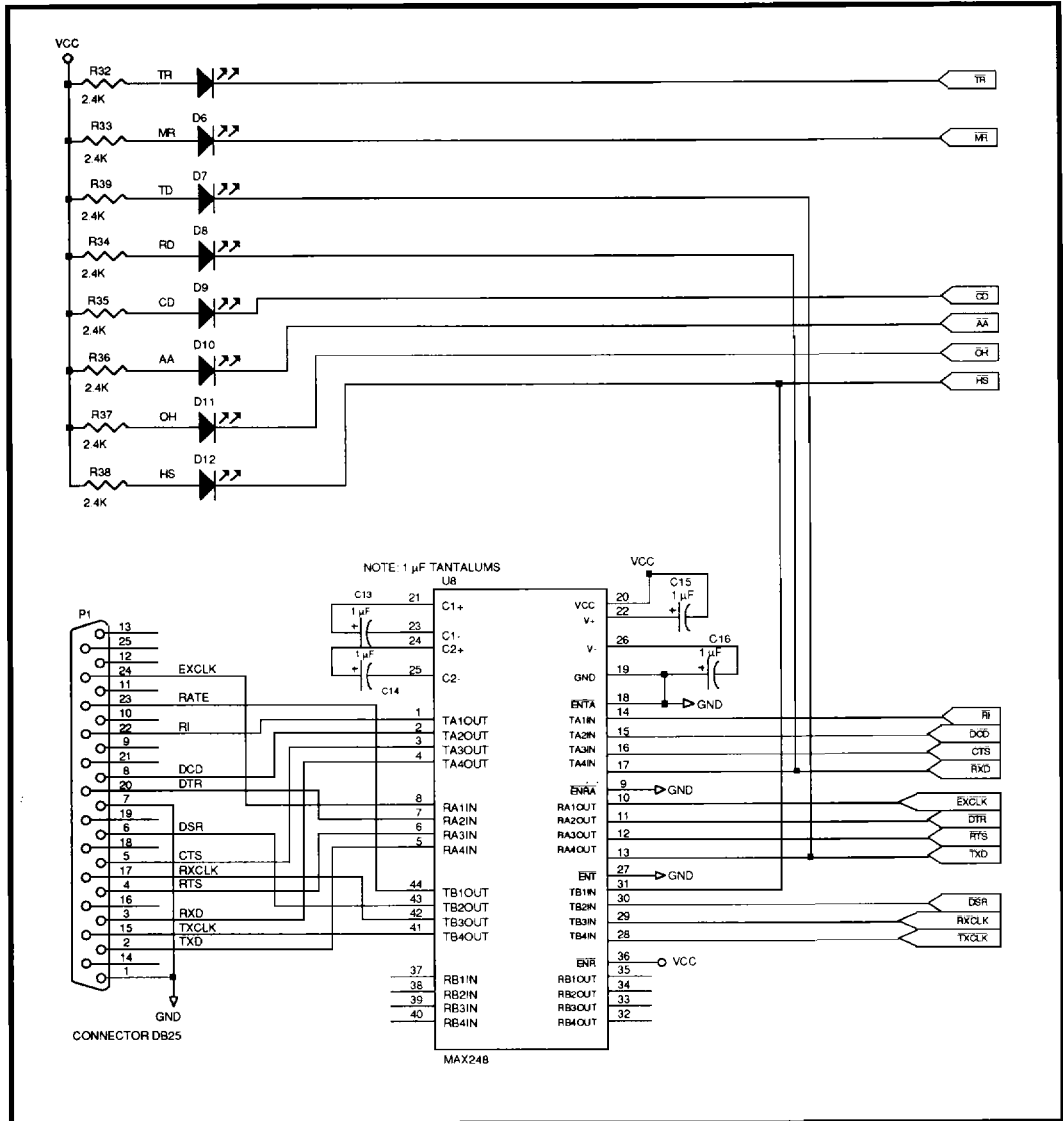

FIGURE 14: Display and User Interface

SSI 73M2910/2910A Microcontroller

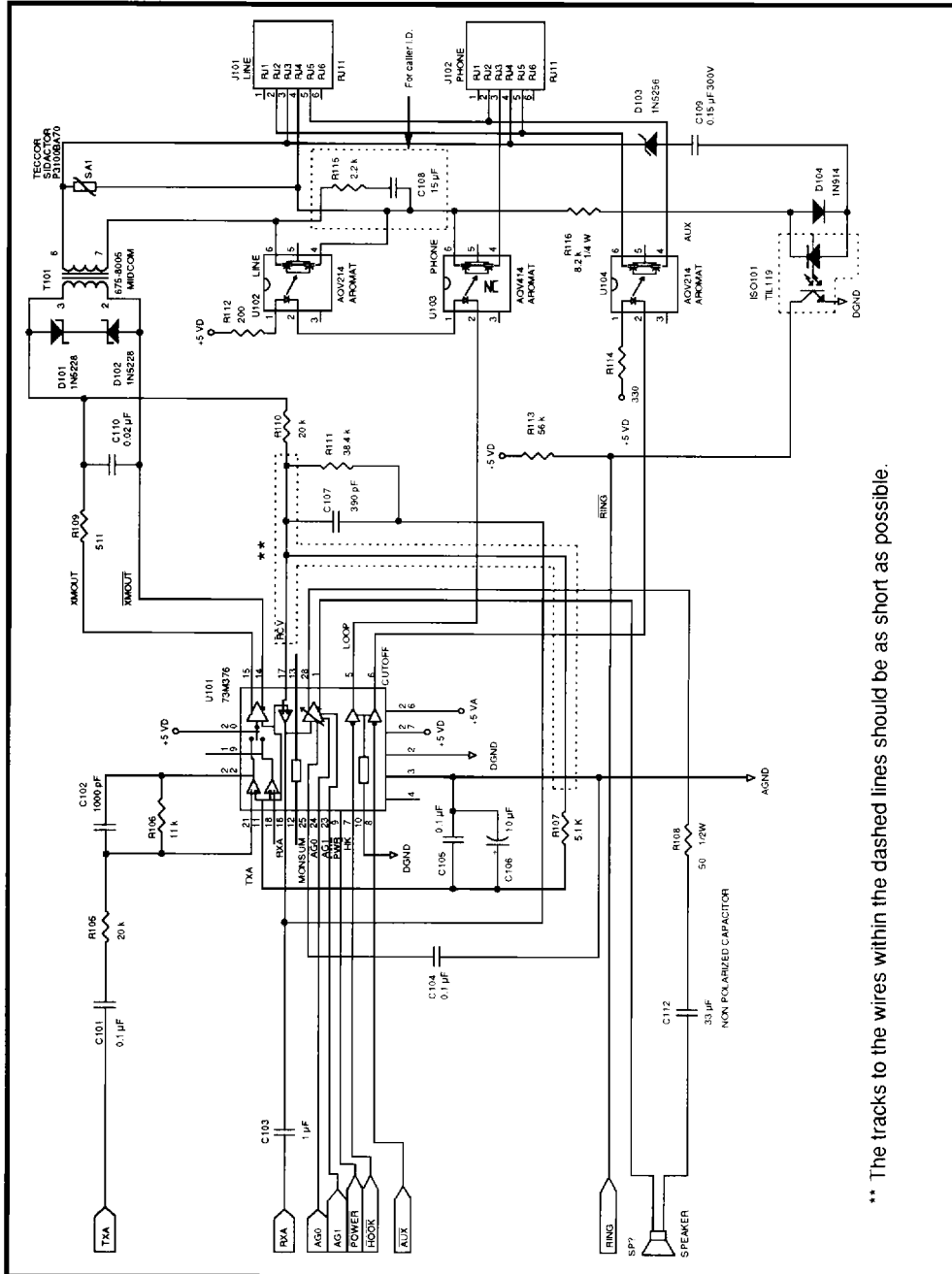
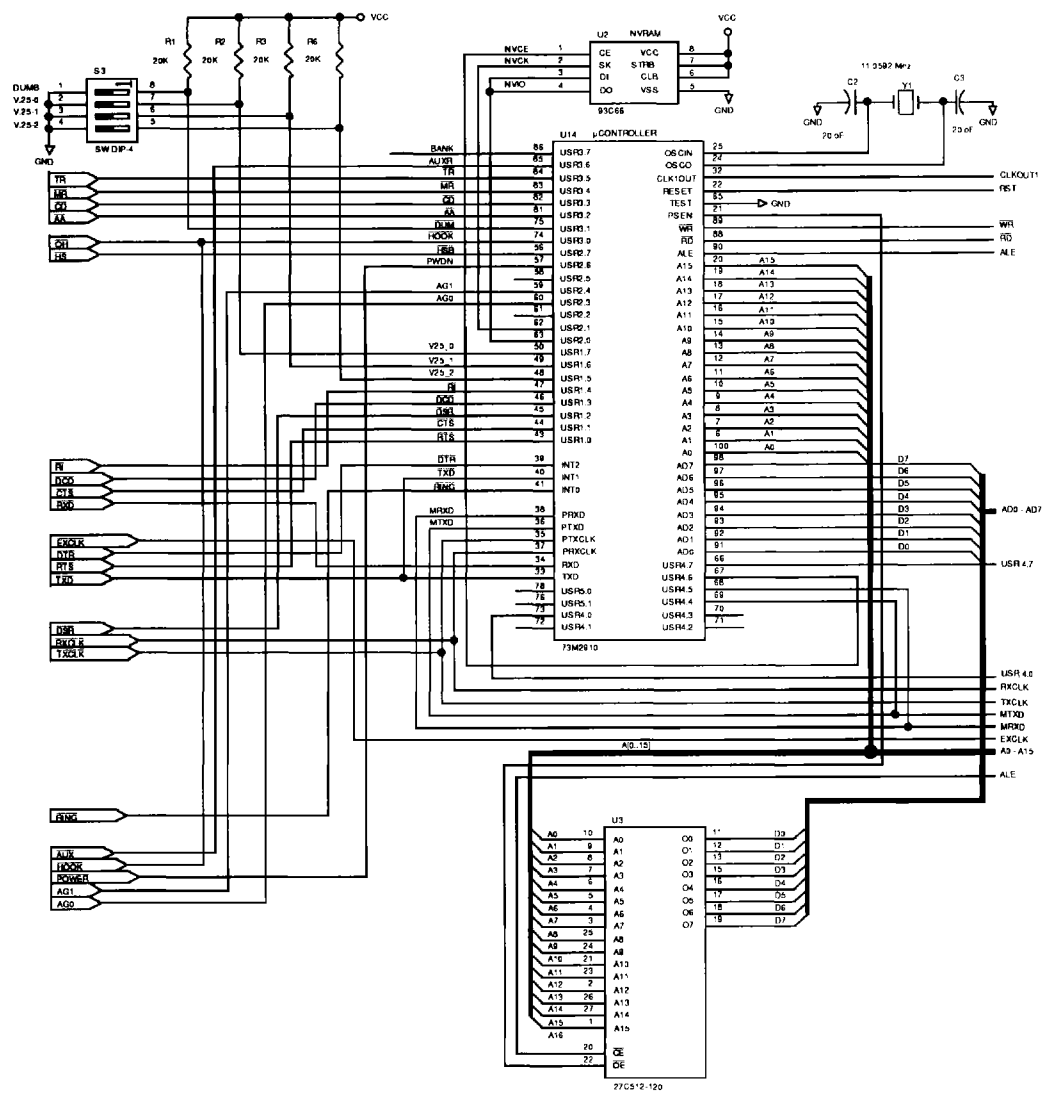

FIGURE 15: Telephone Interface

SSI 73M2910/2910A Microcontroller



4

FIGURE 16A: SSI 73D2248A Modem System Interconnect - Front End

SSI 73M2910/2910A Microcontroller

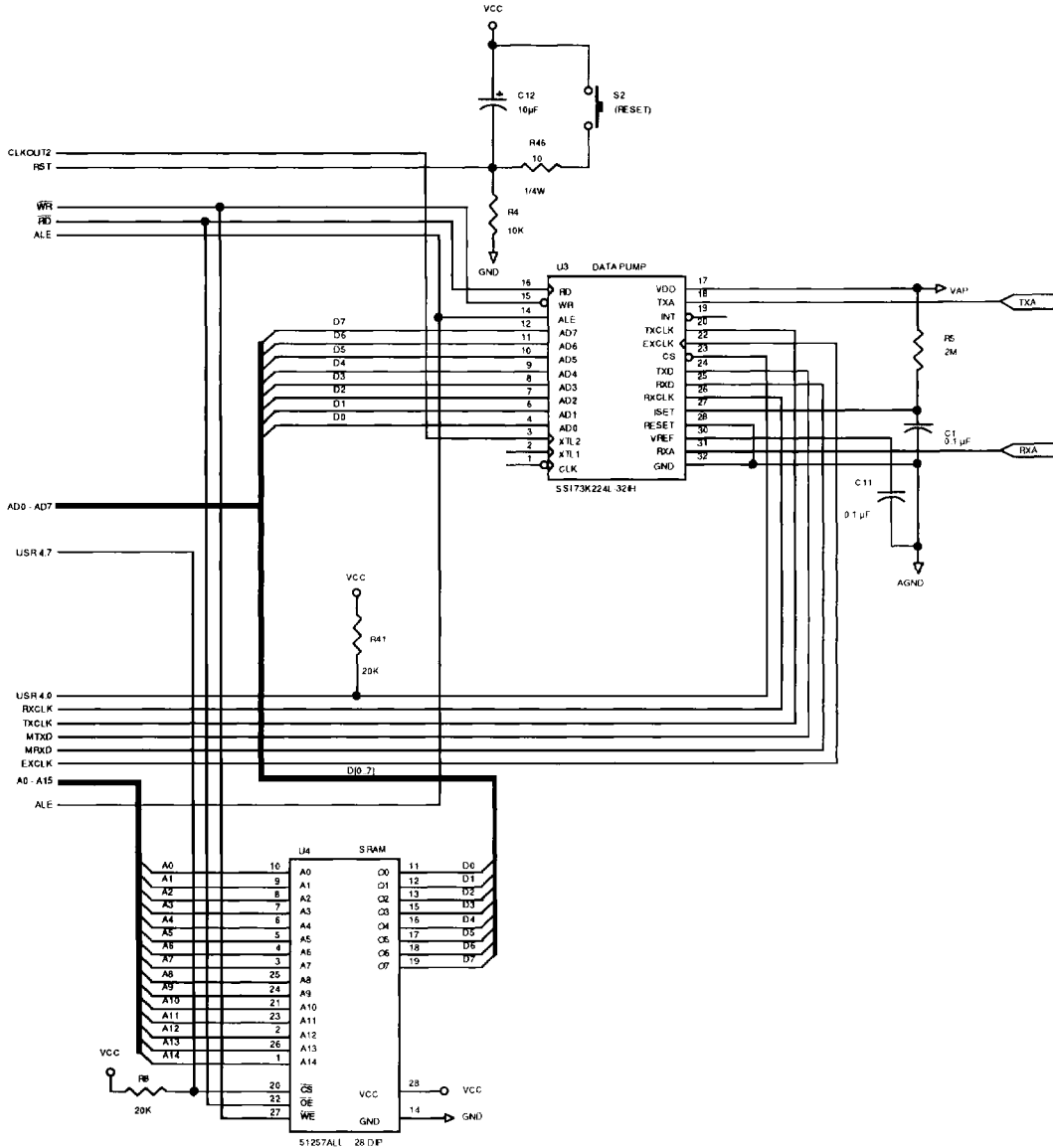

FIGURE 16B: SSI 73D248A Modem System Interconnect - Back End

SSI 73M2910/2910A Microcontroller

100-Pin PGA (For development purposes only; not a production package.)

BOND PRD	PIN #	SIGNAL NAME
1	B2	NO CONNECT
2	B1	NO CONNECT
3	C1	USR26
4	C2	USR27
5	D2	USR25
6	D1	USR24
7	E2	USR23
8	E1	USR22
9	F3	USR21
10	F2	USR20
11	F1	VPD
12	G2	GND
13	G2	USR47
14	G1	USR46
15	H1	USR45
16	H2	USR44
17	H3	USR43
18	J1	USR42
19	J2	USR41
20	K1	USR40
21	K2	USR30
22	L1	USR31
23	M1	USR51
24	L2	NO CONNECT
25	N1	NO CONNECT
26	M2	NO CONNECT
27	N2	NO CONNECT
28	M3	USR50
29	N3	USR32
30	M4	USR33
31	N4	USR34
32	M5	USR35
33	N5	USR36
34	L6	USR37
35	M6	GND
36	N6	\overline{RD}

BOND PRD	PIN #	SIGNAL NAME
37	M7	\overline{WR}
38	L7	ALE
39	N7	D0
40	N8	D1
41	M8	D2
42	L8	D3
43	N9	D4
44	M9	D5
45	N10	D6
46	M10	D7
47	N11	VPD
48	N12	A0
49	M11	NO CONNECT
50	N13	NO CONNECT
51	M12	NO CONNECT
52	M13	NO CONNECT
53	L12	NO CONNECT
54	L13	A1
55	K12	A2
56	K13	A3
57	J12	A4
58	J13	A5
59	H11	A6
60	H12	A7
61	H13	A8
62	G12	A9
63	G11	A10
64	G13	A11
65	F13	A12
66	F12	A13
67	F11	A14
68	E13	A15
69	E12	PSEN
70	D13	RESET
71	D12	GND
72	C13	OSCOUT

SSI 73M2910/2910A Microcontroller

100-Pin PGA (continued)

BOND PRD	PIN #	SIGNAL NAME
73	B13	OSCIN
74	C12	NO CONNECT
75	A13	NO CONNECT
76	B12	NO CONNECT
77	A12	CLK2OUT
78	B11	VPD
79	A11	CLK1OUT
80	B10	TXD
81	A10	RXD
82	B9	PTXCLK
83	A9	PTXD
84	C8	PRXCLK
85	B8	PRXD
86	A8	INT2

BOND PRD	PIN #	SIGNAL NAME
87	B7	INT1
88	C7	INT0
89	A7	GND
90	A6	USR10
91	B6	USR11
92	C6	USR12
93	A5	USR13
94	B5	USR14
95	A4	USR15
96	B4	USR16
97	A3	USR17
98	A2	NO CONNECT
99	B3	NO CONNECT
100	A1	NO CONNECT

100-Pin PGA (For development purposes only; not a production package.)

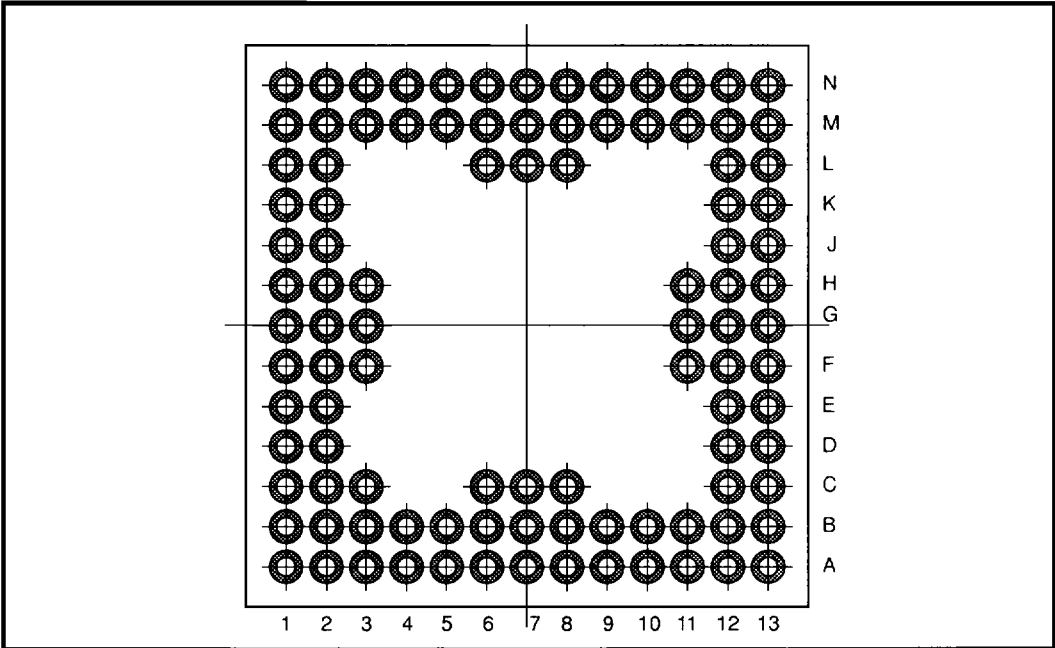
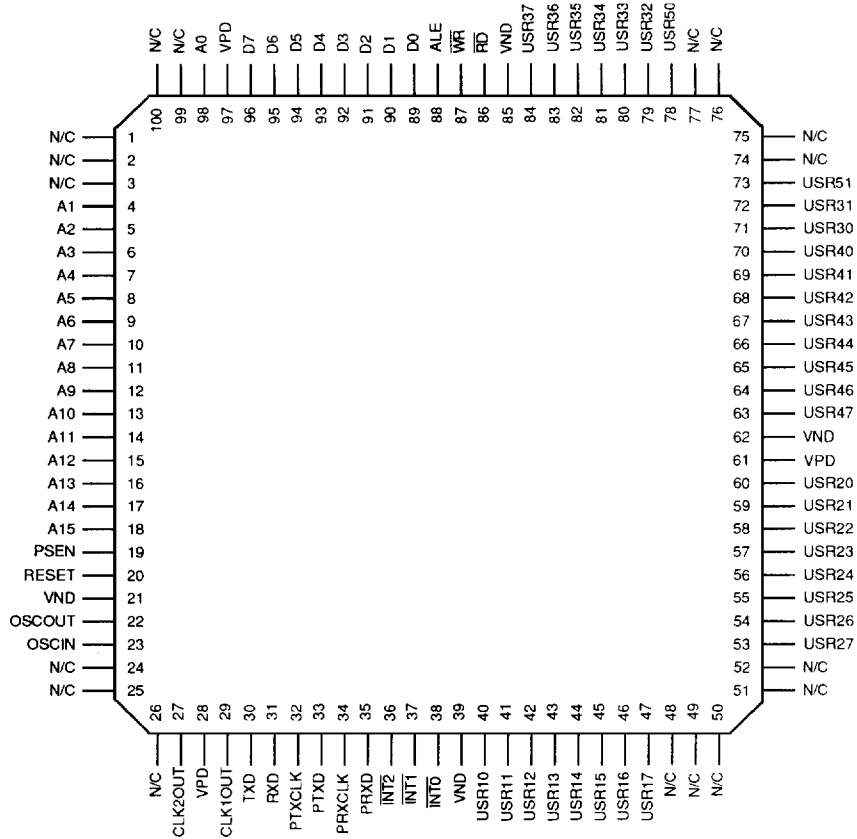

FIGURE 17: 100-Pin Plug-In Package

SSI 73M2910/2910A Microcontroller

PACKAGE PIN DESIGNATIONS

(Top View)



100-Lead TQFP

CAUTION: Use handling procedures necessary for a static sensitive component.

SSI 73M2910/2910A Microcontroller

PACKAGE PIN DESIGNATIONS

(Top View)

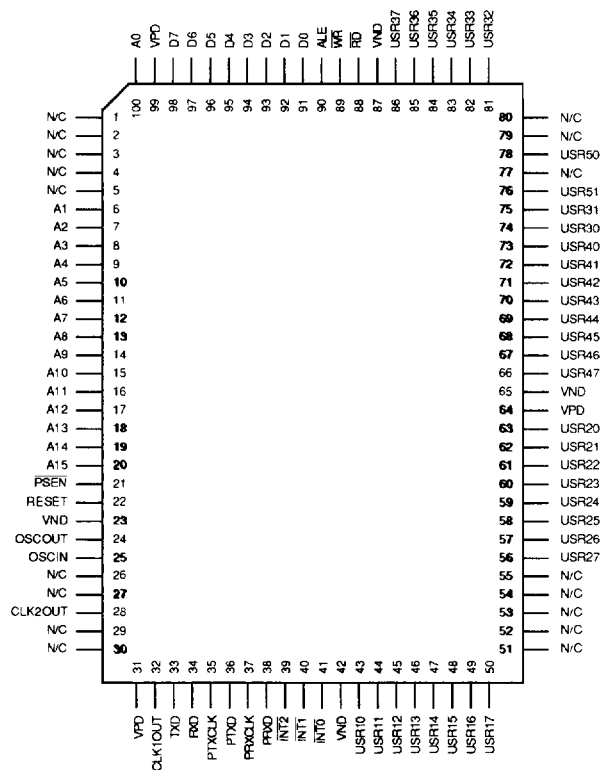

100-Lead QFP

CAUTION: Use handling procedures necessary for a static sensitive component.

No responsibility is assumed by Silicon Systems for use of this product nor for any infringements of patents and trademarks or other rights of third parties resulting from its use. No license is granted under any patents, patent rights or trademarks of Silicon Systems. Silicon Systems reserves the right to make changes in specifications at any time without notice. Accordingly, the reader is cautioned to verify that the data sheet is current before placing orders.

Silicon Systems, Inc., 14351 Myford Road, Tustin, CA 92680-7022 (714) 573-6000, FAX (714) 573-6914