

FEATURES

- Monolithic SONET/SDH Transport Overhead Terminating Transceiver for use in STS-1, STS-3 (STM-1), or STS-12 (STM-4) line interface applications.
- Operates in one of four modes: STS-1 bit serial mode, STS-1 byte serial mode, STS-3/STM-1 byte serial mode, or STS-12/STM-4 byte serial mode.
- Provides independent control of the transmit and receive operating modes.
- Performs byte interleaved multiplexing of lower rate drop side SONET/SDH data streams. STS-3 to STS-1, STM-4 to STM-1 and STS-12 to STS-3 multiplexing modes are supported.
- Processes byte serial data at 6.48 Mbyte/s, 19.44 Mbyte/s or 77.76 Mbyte/s depending on the mode selected.
- Frames to the receive stream by monitoring the status of the upstream pattern detector provided by available Serial to Parallel / Parallel to Serial front end devices.
- Optionally inserts the framing bytes (A1, A2) and the STS identification bytes (C1) into the transmit stream.
- Optionally descrambles the receive STS-1, STS-3/STM-1 or STS-12/STM-4 stream. Optionally scrambles the transmit STS-1, STS-3/STM-1 or STS-12/STM-4 stream.
- Calculates and compares the bit interleaved parity error detection codes (B1, B2) for the receive stream. Calculates and inserts B1 and B2 in the transmit stream.
- Optionally inserts line far end block errors (FEBE) into the Z2 growth byte based on received B2 errors.
- Accumulates near end errors (B1, B2) and far end errors (Z2) for performance monitoring purposes.
- Extracts the order wire channels (E1, E2) of the receive stream and serializes them at 64 kbit/s. Optionally inserts the order wire channels into the transmit stream.
- Extracts the data communication channels (D1-D3, D4-D12) and serializes them at 192 kbit/s (D1-D3) and 576 kbit/s (D4-D12). Optionally inserts the data communication channels into the transmit stream.
- Extracts the section user channel (F1) and serializes it at 64 kbit/s. Optionally inserts the section user channel into the transmit stream.

- Extracts the automatic protection switch (APS) channel (K1, K2) and serializes it at 128 kbit/s.
- Detects loss of signal (LOS), out of frame (OOF), loss of frame (LOF), far end receive failure (FERF), line alarm indication signal (AIS), and protection switching byte failure alarms.
- Inserts FERF and AIS in the transmit stream.
- Provides loss of signal insertion, framing pattern error insertion, and coding violation insertion (B1 and B2) for diagnostic purposes.
- Provides a transmit and receive ring control port, allowing alarm and maintenance signal control and status to be passed between mate STTXs for applications in ring-based add drop multiplexers.
- Low power +5 Volt 0.8 micron CMOS with TTL/CMOS compatible inputs and outputs.
- 180 pin CPGA package or 208 pin copper slugged PQFP package.

APPLICATIONS

- OC-N to OC-M multiplexers
- SONET/SDH add drop multiplexers
- SONET/SDH terminal multiplexers
- Broadband ISDN user network interfaces
- ATM Transmission systems
- SONET/SDH test equipment

REFERENCES

- American National Standard for Telecommunications - Digital Hierarchy - Optical Interface Rates and Formats Specification, ANSI T1.105-1991.
- Bell Communications Research - SONET Transport Systems: Common Generic Criteria, TR-NWT-000253, Issue 2, December, 1991.

APPLICATION EXAMPLES

The following two diagrams shown the STTX used in an ATM application as an STS-3c/STM-1 to STS-12/STM-4 multiplexer using four PM5345 SUNI-155 ATM interface chips, and in an add-drop multiplexer application using four PM5344 SPTX path termination chips instead of the SUNI-155 chips to achieve access to circuit-switched bandwidth. Serial to Parallel / Parallel to Serial conversion, clock recovery and clock synthesis is available from a number of commercial sources.

622 Mbit/s SONET/SDH Asynchronous Transfer Mode Multiplexer

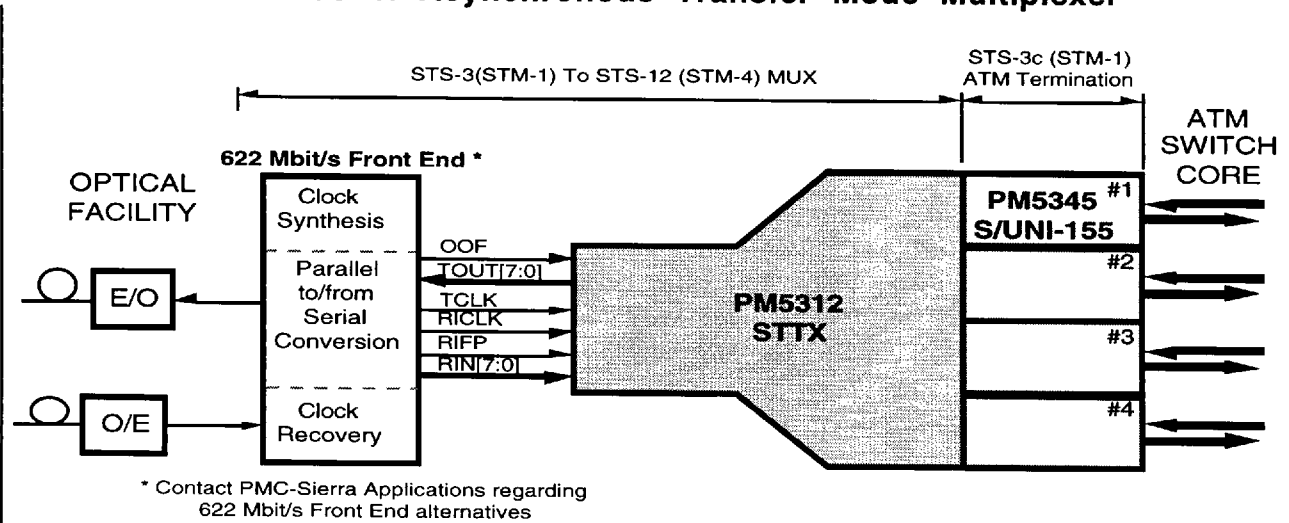

622 Mbit/s SONET/SDH Add-Drop Multiplexer Aggregate Interface

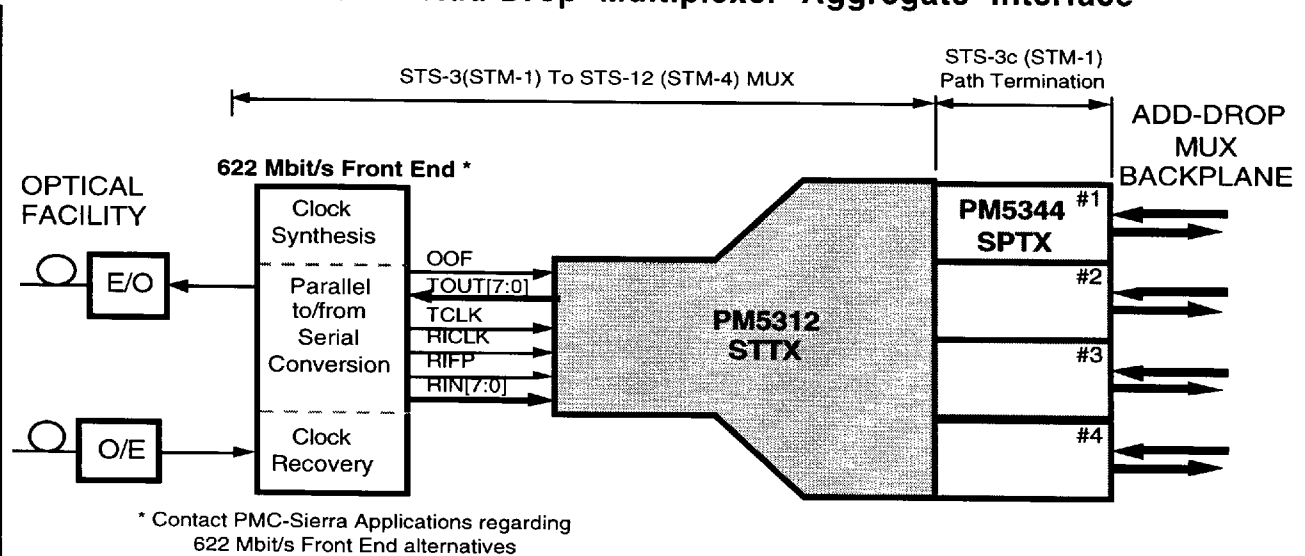

BLOCK DIAGRAM

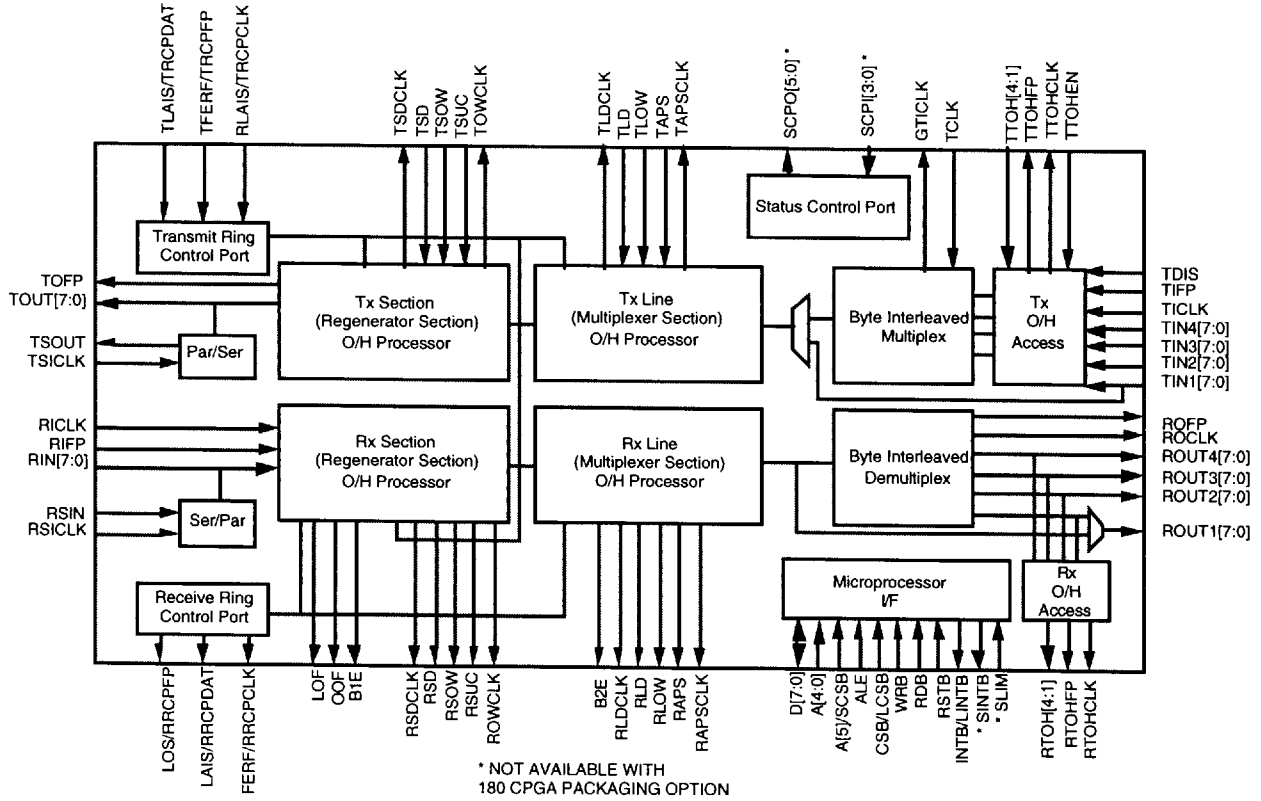

DESCRIPTION

The PM5312 STTX SONET/SDH Transport Overhead Terminating Transceiver processes the transport overhead (regenerator and multiplexer section overhead) of STS-1, STS-3/STM-1, and STS-12/STM-4 streams and optionally provides byte interleaved multiplexing of lower rate streams.

The STTX may be used on the line side of four PM5344 SPTX SONET/SDH Path Terminating Transceiver devices to implement a full SONET/SDH path transmission system capable of terminating 12 STS-1 or four STS-3/STM-1 channels.

In a similar fashion, the STTX may be used on the line side of four PM5345 SUNI Saturn User Network Interface devices to implement an Asynchronous Transfer Mode (ATM) Multiplexer which takes four logical ATM streams operating at 155 Mbit/s and synchronously multiplexes them into a single 622 Mbit/s stream.

PIN DIAGRAM

The STTX is available in a 180 pin CPGA package with 100 mil pin spacing.

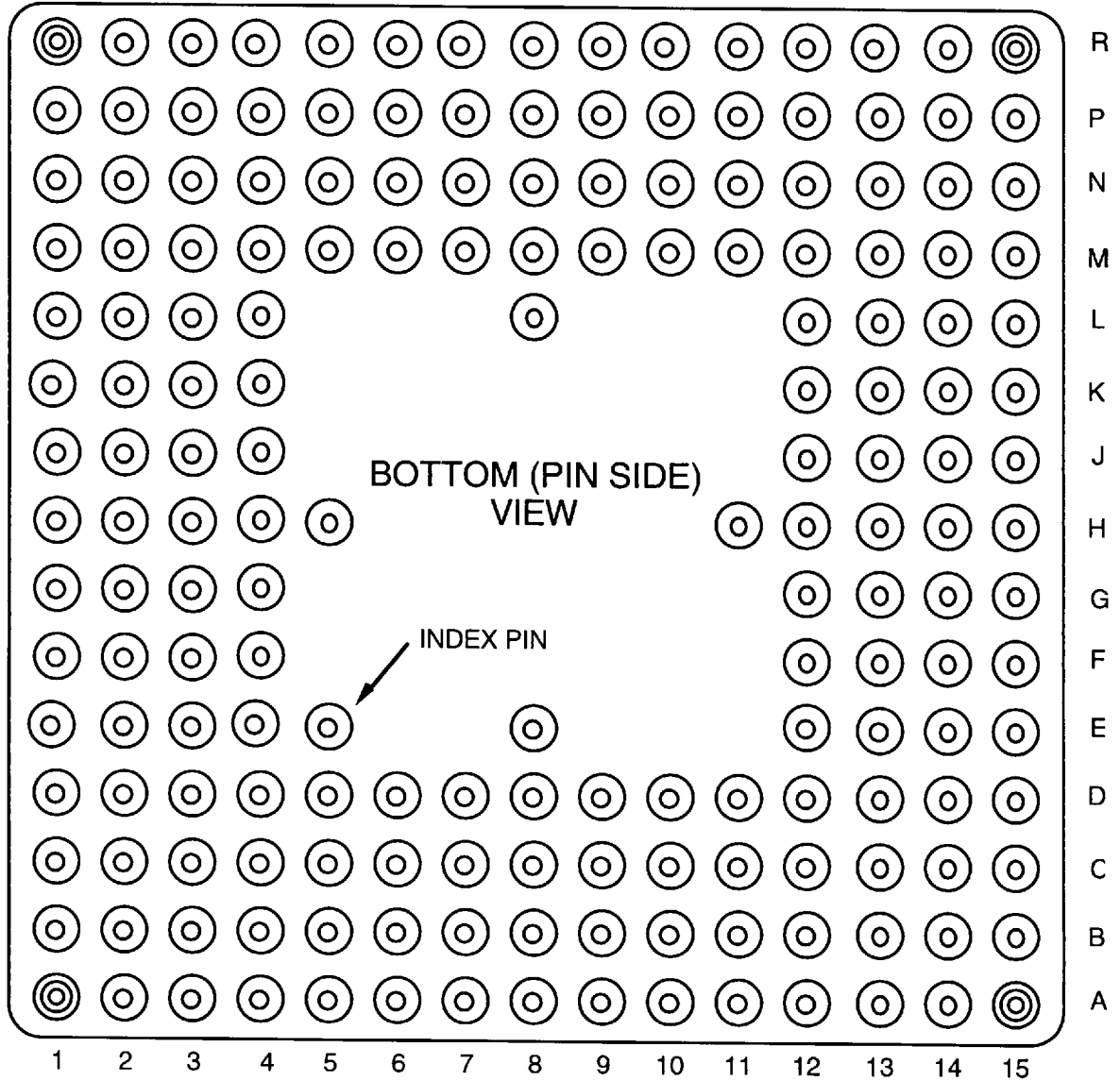

The STTX is also available in a 208 pin slugged PQFP package having a body size of 28 mm by 28 mm and a pin pitch of 0.5 mm.

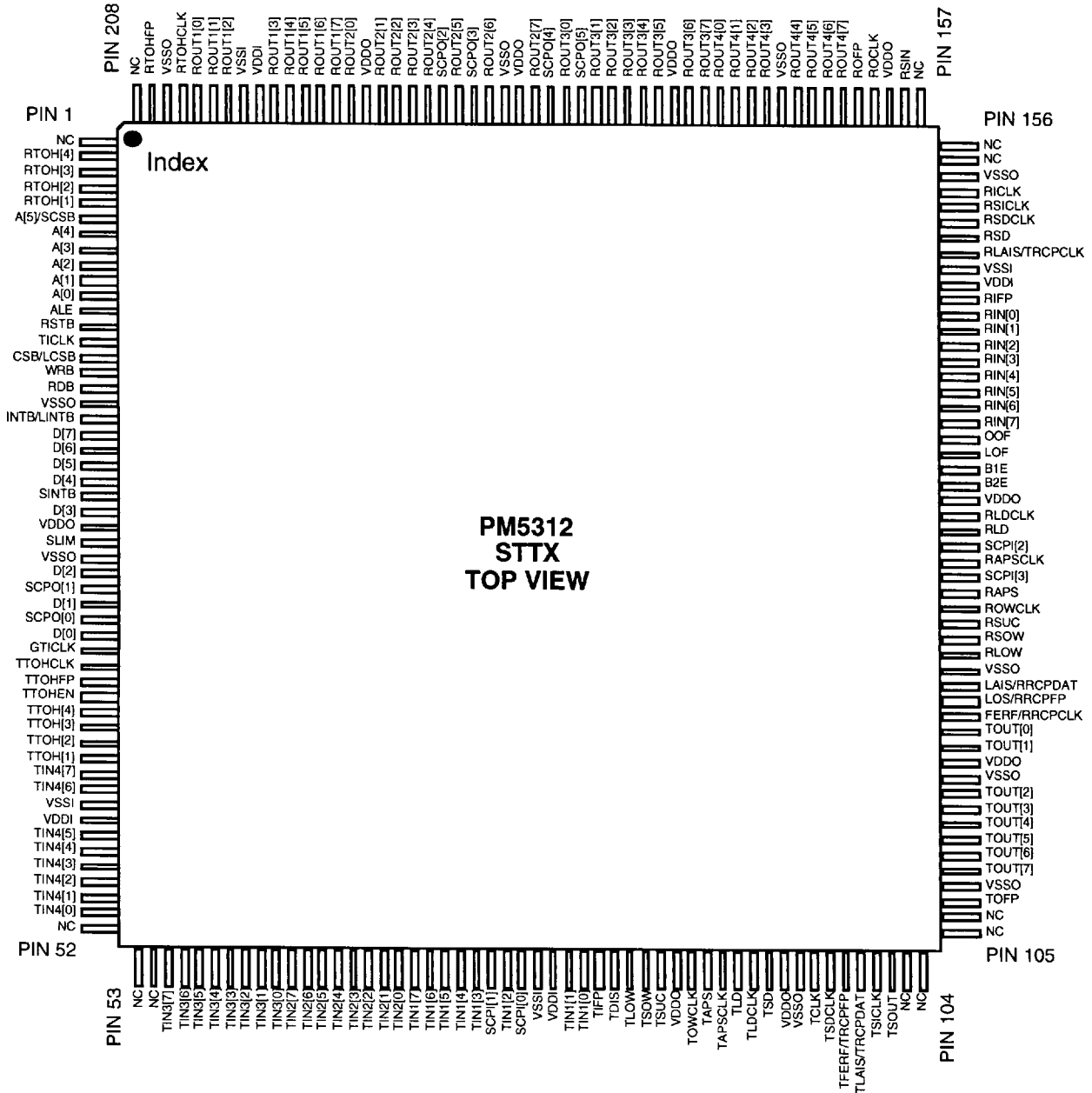

PIN DESCRIPTION

Pin Name	Pin Type	CPGA Pin No.	PQFP Pin No.	Function
RICLK <i>RVCLK</i>	Input	E4	153	<p>The receive incoming clock (RICLK) provides timing for processing the byte serial receive stream, RIN[7:0]. RICLK is nominally a 6.48 MHz (STS-1), 19.44 MHz (STS-3/STM-1), or 77.76 MHz (STS-12/STM-4) 50% duty cycle clock, depending on the selected operating mode. RIN[7:0], and RIFP are sampled on the rising edge of RICLK.</p> <p><i>The receive vector clock (RVCLK) is used during STTX production test to verify internal functionality.</i></p>
RIN[7] RIN[6] RIN[5] RIN[4] RIN[3] RIN[2] RIN[1] RIN[0]	Input Input Input Input Input Input Input Input	E1 G3 G4 F2 D1 E2 C1 B1	138 139 140 141 142 143 144 145	<p>The receive incoming stream (RIN[7:0]) carries the scrambled STS-1, STS-3/STM-1, or STS-12/STM-4 stream in byte serial format. RIN[7] is the most significant bit (corresponding to bit 1 of each serial PCM word, the first bit transmitted). RIN[0] is the least significant bit (corresponding to bit 8 of each serial PCM word, the last bit transmitted). RIN[7:0] is sampled on the rising edge of RICLK.</p>
RIFP	Input	D2	146	<p>The active high receive incoming framing position (RIFP) signal indicates the frame alignment in the incoming stream, RIN[7:0]. RIFP is sampled on the rising edge of RICLK.</p>
RSICLK	Input	B2	152	<p>The receive serial incoming clock (RSICLK) provides timing for processing the bit serial receive stream, RSIN. RSICLK is nominally a 51.84 MHz, 50% duty cycle clock. RSIN is sampled on the rising edge of RSICLK. RSICLK is divided by eight to produce ROCLK when the bit serial STS-1 mode is selected. RSICLK should be disabled when the bit serial STS-1 interface is not used.</p>
RSIN	Input	C4	158	<p>The receive incoming serial stream (RSIN) carries the scrambled STS-1 stream in bit serial format. RSIN is sampled on the rising edge of RSICLK.</p>

RLAIS/ TRCPCLK	Input	E3	149	<p>The receive line AIS insertion (RLAIS) signal controls the insertion of line AIS in the receive outgoing streams, ROUT1[7:0], ROUT2[7:0], ROUT3[7:0], and ROUT4[7:0] when the ring control port is disabled. When RLAIS is high, line AIS is inserted in the outgoing streams. Line AIS is also optionally inserted automatically upon detection of loss of signal, loss of frame, or line AIS in the incoming stream. RLAIS is sampled on the rising edge of RICLK.</p> <p>The transmit ring control port clock (TRCPCLK) signal provides timing for the transmit ring control port when the ring control port is enabled (the enabling and disabling of the ring control port is controlled by a bit in the Master Control Register). TRCPCLK is nominally a 3.24 MHz, 50% duty cycle clock and is normally connected to the RRCCLK output of a mate STTX in ring-based add-drop multiplexer applications. TRCPFP and TRCPDAT are sampled on the rising edge of TRCPCLK.</p>
OOF	Output	G2	137	<p>The out of frame (OOF) signal is set high while the STTX is unable to find a valid framing pattern (A1, A2) in the incoming stream. OOF is set low when a valid framing pattern is detected. OOF is updated on the rising edge of RICLK.</p>
LOF	Output	F1	136	<p>The loss of frame (LOF) signal is set high when an out of frame state persists for 3 ms. LOF is set low when an in frame state persists for 3 ms. LOF is updated on the rising edge of RICLK.</p>

LOS/ RRCPPF	Output	L1	120	<p>Loss of signal (LOS) is active when the ring control port is disabled. Loss of signal (LOS) is set high when a violating period ($20 \pm 2.5 \mu\text{s}$) of consecutive all zeros patterns is detected in the incoming stream. LOS is set low when two valid framing words (A1, A2) are detected, and during the intervening time ($125 \mu\text{s}$), no violating period of all zeros patterns is observed. LOS is updated on the rising edge of RICLK.</p> <p>The receive ring control port frame position (RRCPPF) signal identifies bit positions in the receive ring control port data (RRCPDAT) when the ring control port is enabled (the enabling and disabling of the ring control port is controlled by a bit in the Master Control Register). RRCPPF is high during the filtered K1, K2 bit positions, the change of APS value bit position, the protection switch byte failure bit position, and the send AIS and send FERF bit positions in the RRCPDAT stream. RRCPPF is normally connected to the TRCPFP input of a mate STTX in ring-based add-drop multiplexer applications. RRCPPF is updated on the falling edge of RRCPCLK.</p>
B1E	Output	G1	135	<p>The B1 error clock (B1E) is a return to zero signal that pulses once for every section bit interleaved parity error (B1) detected in the incoming stream. Up to eight pulses may occur on B1E per frame.</p>

LAIS/ RRCPCDAT	Output	K2	121	<p>The line alarm indication (LAIS) signal is active when the ring control port is disabled. LAIS is set high when line AIS is detected in the incoming stream. LAIS is declared when a 111 binary pattern is detected in bits 6, 7, and 8 of the K2 byte for three or five consecutive frames. LAIS is removed when any pattern other than 111 is detected in bits 6, 7, and 8 of the K2 byte for three or five consecutive frames. This alarm indication is also available through register access. LAIS is updated on the rising edge of RICK.</p> <p>The receive ring control port data (RRCPCDAT) signal contains the receive ring control port data stream when the ring control port is enabled (the enabling and disabling of the ring control port is controlled by a bit in the Master Control Register). The receive ring control port data consists of the filtered K1, K2 byte values, the change of APS value bit position, the protection switch byte failure status bit position, the send AIS and send FERF bit positions, and the line FEBE bit positions. RRCPCDAT is normally connected to the TRCPCDAT input of a mate STTX in ring-based add-drop multiplexer applications. RRCPCDAT is updated on the falling edge of RRCPCCLK.</p>
B2E	Output	H1	134	<p>The B2 error clock (B2E) is a return to zero signal that pulses once for every line bit interleaved parity error (B2) detected in the incoming stream. Up to 8 (STS-1), 24 (STS-3/STM-1), or 96 (STS-12/STM-4) pulses may occur on B2E, per frame.</p>
RSDCLK	Output	D3	151	<p>The receive section DCC clock (RSDCLK) is a 192 kHz clock used to update the RSD output. RSDCLK is generated by gapping a 216 kHz clock.</p>
RSD	Output	C2	150	<p>The receive section DCC (RSD) signal contains the section data communications channel (D1, D2, D3) extracted from the incoming stream. RSD is updated on the falling edge of RSDCLK.</p>

ROWCLK	Output	J1	126	The receive order wire clock (ROWCLK) is a 64 kHz clock used to update the RSOW, RSUC, and RLOW outputs. ROWCLK is generated by gapping a 72 kHz clock.
RSOW	Output	J3	124	The receive section order wire (RSOW) signal contains the section order wire channel (E1) extracted from the incoming stream. RSOW is updated on the falling edge of ROWCLK.
RSUC	Output	J2	125	The receive section user channel (RSUC) signal contains the section user channel (F1) extracted from the incoming stream. RSUC is updated on the falling edge of ROWCLK.
RLOW	Output	K1	123	The receive line order wire (RLOW) signal contains the line order wire channel (E2) extracted from the incoming stream. RLOW is updated on the falling edge of ROWCLK.
RLDCLK	Output	H5	132	The receive line DCC clock (RLDCLK) is a 576 kHz clock used to update the RLD output. RLDCLK is generated by gapping a 2.16 MHz clock.
RLD	Output	H4	131	The receive line DCC (RLD) signal contains the line data communications channel (D4 - D12) extracted from the incoming stream. RLD is updated on the falling edge of RLDCLK.
RAPSCLK	Output	H3	129	The receive automatic protection switch channel clock (RAPSCLK) is a 128 kHz clock used to update the RAPS output. RAPSCLK is generated by gapping a 144 kHz clock.
RAPS	Output	H2	127	The receive automatic protection switch channel (RAPS) signal carries the automatic protection switch channel (K1, K2) extracted from the incoming stream. RAPS is updated on the falling edge of RAPSCLK.

RTOH[4]	Output	D13	2	<p>The receive transport overhead bus (RTOH[4:1]) contains the receive transport overhead bytes (A1, A2, C1, B1, E1, F1, D1-D3, H1-H3, B2, K1, K2, D4-D12, Z1, Z2, and E2) extracted from the incoming stream. When STS-12/STM-4 mode is selected, RTOH[1] contains the transport overhead from STS-3/STM-1 #1, RTOH[2] contains the transport overhead for STS-3/STM-1 #2, RTOH[3] contains the transport overhead for STS-3/STM-1 #3, and RTOH[4] contains the transport overhead for STS-3/STM-1 #4. When STS-3/STM-1 mode or STS-1 mode are selected, the complete transport overhead is extracted on RTOH[1]. RTOH[4:1] is updated on the falling edge of RTOHCLK.</p>
RTOH[3]	Output	E12	3	
RTOH[2]	Output	C13	4	
RTOH[1]	Output	A15	5	
RTOHCLK	Output	B14	205	<p>The receive transport overhead clock (RTOHCLK) is nominally a 5.184 MHz clock that provides timing to process the extracted receive transport overhead bus, RTOH[4:1]. RTOHCLK is a gapped 6.48 MHz clock when accessing the transport overhead of STS-3/STM-1 streams. RTOHCLK is a gapped 2.16 MHz clock when accessing the transport overhead of an STS-1 stream.</p>
RTOHFP	Output	D12	207	<p>The receive transport overhead frame position (RTOHFP) signal is used to locate the individual receive transport overhead bits in the transport overhead bus, RTOH[4:1]. RTOHFP is set high while bit 1 (the most significant bit) of the first framing byte (A1) is present in the RTOH[4:1] stream. RTOHFP is updated on the falling edge of RTOHCLK.</p>

ROCLK	Output	C3	160	<p>The receive outgoing clock (ROCLK) provides timing for updating the demultiplexed byte serial STS-1 or STS-3/STM-1 outputs, ROUT1[7:0], ROUT2[7:0], ROUT3[7:0], and ROUT4[7:0] when 1:3 or 1:4 byte interleaved multiplexing is enabled. ROCLK is nominally a 6.48 MHz, or 19.44 MHz clock, depending on the demultiplexing mode selected. ROCLK remains inactive when demultiplexing is bypassed.</p> <p>When the bit serial STS-1 receive interface is enabled, ROCLK becomes the generated byte serial clock. ROCLK is a 6.48 MHz clock that is generated by dividing the receive serial incoming clock (RSICLK) by eight. ROCLK must be connected externally to the receive incoming clock (RICKL) when processing a bit serial STS-1 stream.</p>
ROUT1[7] ROUT1[6] ROUT1[5] ROUT1[4] ROUT1[3] ROUT1[2] ROUT1[1] ROUT1[0]	Output Output Output Output Output Output Output Output	A12 B11 A13 A14 B12 C11 B13 C12	195 196 197 198 199 202 203 204	<p>The receive outgoing #1 bus, (ROUT1[7:0]), carries demultiplexed STS-1 or STS-3/STM-1 streams in byte serial format. ROUT1[7] is the most significant bit (corresponding to bit 1 of each serial PCM word, the first bit received). ROUT1[0] is the least significant bit (corresponding to bit 8 of each serial PCM word). ROUT1[7:0] is updated on the falling edge of ROCLK.</p> <p>ROUT1[7:0] contains the entire descrambled outgoing stream and is updated on the rising edge of RICKL when demultiplexing is bypassed, or when the bit serial STS-1 mode is selected. Note that demultiplex bypass is supported for STS-3 mode only.</p>
ROUT2[7] ROUT2[6] ROUT2[5] ROUT2[4] ROUT2[3] ROUT2[2] ROUT2[1] ROUT2[0]	Output Output Output Output Output Output Output Output	D8 A8 A9 A10 B9 A11 C9 B10	182 185 187 189 190 191 192 194	<p>The receive outgoing #2 bus, (ROUT2[7:0]), carries demultiplexed STS-1 or STS-3/STM-1 streams in byte serial format. ROUT2[7] is the most significant bit (corresponding to bit 1 of each serial PCM word, the first bit received). ROUT2[0] is the least significant bit (corresponding to bit 8 of each serial PCM word). ROUT2[7:0] is updated on the falling edge of ROCLK.</p>

ROUT3[7]	Output	A5	171	The receive outgoing #3 bus, (ROUT3[7:0]), carries demultiplexed STS-1 or STS-3/STM-1 streams in byte serial format. ROUT3[7] is the most significant bit (corresponding to bit 1 of each serial PCM word, the first bit transmitted). ROUT3[0] is the least significant bit (corresponding to bit 8 of each serial PCM word). ROUT3[7:0] is updated on the falling edge of ROCLK.
ROUT3[6]	Output	B6	172	
ROUT3[5]	Output	A6	174	
ROUT3[4]	Output	C7	175	
ROUT3[3]	Output	B7	176	
ROUT3[2]	Output	A7	177	
ROUT3[1]	Output	B8	178	
ROUT3[0]	Output	C8	180	
ROUT4[7]	Output	B3	162	The receive outgoing #4 bus, (ROUT4[7:0]), carries demultiplexed STS-3/STM-1 streams in byte serial format. ROUT4[7] is the most significant bit (corresponding to bit 1 of each serial PCM word, the first bit transmitted). ROUT4[0] is the least significant bit (corresponding to bit 8 of each serial PCM word). ROUT4[7:0] is updated on the falling edge of ROCLK. ROUT4[7:0] is not used when demultiplexing an STS-3 stream into three STS-1 streams.
ROUT4[6]	Output	A2	163	
ROUT4[5]	Output	A3	164	
ROUT4[4]	Output	C5	165	
ROUT4[3]	Output	C6	167	
ROUT4[2]	Output	B4	168	
ROUT4[1]	Output	B5	169	
ROUT4[0]	Output	A4	170	
ROFP	Output	A1	161	<p>The active high receive outgoing frame position (ROFP) signal is set high once per frame in the byte position immediately following the C1 bytes in the ROUT1[7:0], ROUT2[7:0], ROUT3[7:0], and ROUT4[7:0] STS-1 or STS-3/STM-1 streams. ROFP is updated on the falling edge of ROCLK.</p> <p>ROFP is also used to mark the alignment of the RSOW, RSUC, RLOW and RAPS bit streams.</p> <p>ROFP is updated on the rising edge of RICKL when demultiplexing is bypassed, or when the bit serial STS-1 mode is selected. Note that demultiplex bypass is supported for STS-3 mode only.</p>

TCLK TVCLK	Input	N5	97	<p>The transmit clock (TCLK) provides timing for multiplexing the byte serial incoming streams, TIN1[7:0], TIN2[7:0], TIN3[7:0] and TIN4[7:0], into a higher rate stream. TCLK is nominally a 6.48 MHz, 19.44 MHz or 77.76 MHz 50% duty cycle clock, depending on the operating mode selected. When multiplexing is bypassed, or when STS-1 mode is selected, the incoming stream, TIN1[7:0], is sampled on the rising edge of TCLK.</p> <p><i>The transmit vector clock (TVCLK) is used during STTX production test to verify internal functionality.</i></p>
GTICKL	Output	J14	34	<p>The generated transmit clock (GTICKL) is used in contra-directional timing-based systems to provide timing for upstream circuitry. GTICKL is a divide by four of the high speed multiplex clock (TCLK) when STS-3 to STS-12 multiplexing is enabled. GTICKL is a divide by three of TCLK when STS-1 to STS-3 multiplexing is enabled. GTICKL must be connected directly to TICKL for these contra-directional multiplexing applications. GTICKL is a divide by eight of the transmit serial incoming clock (TSICKL) when the bit serial STS-1 mode is enabled. GTICKL must be connected directly to TCLK for these contra-directional STS-1 applications.</p>
TICKL	Input	D15	14	<p>The transmit incoming clock (TICKL) provides timing to sample the byte serial incoming streams prior to multiplexing. TICKL is synchronous with, but arbitrarily phase aligned to TCLK. TICKL is nominally a 6.48 MHz, or 19.44 MHz clock. TIN1[7:0], TIN2[7:0], TIN3[7:0], TIN4[7:0], TDIS, and TIFP are sampled on the rising edge of TICKL.</p>
TSICKL	Input	M5	101	<p>The transmit serial incoming clock (TSICKL) provides timing for updating the bit serial outgoing stream when STS-1 mode is selected. TSICKL is nominally a 51.84 MHz, 50% duty cycle clock. TSOUT is updated on the rising edge of TSICKL. TSICKL should be disabled when the bit serial STS-1 interface is not used.</p>

TIN1[7] TIN1[6] TIN1[5] TIN1[4] TIN1[3] TIN1[2] TIN1[1] TIN1[0]	Input	R10 N9 P9 R9 P8 N8 R8 R7	71 72 73 74 75 77 81 82	<p>The transmit incoming #1 bus, (TIN1[7:0]), carries STS-1 or STS-3/STM-1 streams in byte serial format. TIN1[7] is the most significant bit (corresponding to bit 1 of each serial PCM word, the first bit transmitted). TIN1[0] is the least significant bit (corresponding to bit 8 of each serial PCM word). TIN1[7:0] is sampled on the rising edge of TICLK.</p> <p>TIN1[7:0] contains the entire incoming stream and is sampled on the rising edge of TCLK when multiplexing is bypassed, or when the STS-1 mode is selected. Note that multiplex bypass is supported for STS-3 mode only.</p>
TIN2[7] TIN2[6] TIN2[5] TIN2[4] TIN2[3] TIN2[2] TIN2[1] TIN2[0]	Input	M10 N10 P12 P11 R12 R11 P10 M9	63 64 65 66 67 68 69 70	<p>The transmit incoming #2 bus, (TIN2[7:0]), carries STS-1 or STS-3/STM-1 streams in byte serial format. TIN2[7] is the most significant bit (corresponding to bit 1 of each serial PCM word, the first bit transmitted). TIN2[0] is the least significant bit (corresponding to bit 8 of each serial PCM word). TIN2[7:0] is sampled on the rising edge of TICLK.</p>
TIN3[7] TIN3[6] TIN3[5] TIN3[4] TIN3[3] TIN3[2] TIN3[1] TIN3[0]	Input	N12 M11 N13 R15 P13 R14 R13 N11	55 56 57 58 59 60 61 62	<p>The transmit incoming #3 bus, (TIN3[7:0]), carries STS-1 or STS-3/STM-1 streams in byte serial format. TIN3[7] is the most significant bit (corresponding to bit 1 of each serial PCM word, the first bit transmitted). TIN3[0] is the least significant bit (corresponding to bit 8 of each serial PCM word). TIN3[7:0] is sampled on the rising edge of TICLK.</p>
TIN4[7] TIN4[6] TIN4[5] TIN4[4] TIN4[3] TIN4[2] TIN4[1] TIN4[0]	Input	P15 M14 L13 N14 M13 P14 L12 M12	42 43 46 47 48 49 50 51	<p>The transmit incoming #4 bus, (TIN4[7:0]), carries STS-3/STM-1 streams in byte serial format. TIN4[7] is the most significant bit (corresponding to bit 1 of each serial PCM word, the first bit transmitted). TIN4[0] is the least significant bit (corresponding to bit 8 of each serial PCM word). TIN4[7:0] is sampled on the rising edge of TICLK. TIN4[7:0] is not used when multiplexing three STS-1 streams to an STS-3 stream.</p>

TIFP	Input	R6	83	<p>The active high transmit incoming framing position (TIFP) signal indicates the frame alignment for incoming streams. A high level on TIFP marks the byte immediately following the C1 bytes in the transmit STS-1 or STS-3 (STM-1) streams, TIN1[7:0], TIN2[7:0], TIN3[7:0], and TIN4[7:0]. TIFP is sampled on the rising edge of TICLK.</p> <p>TIFP is sampled on the rising edge of TCLK when multiplexing is bypassed, or when the bit serial STS-1 mode is selected. Note that multiplex bypass is supported for STS-3 mode only.</p>
TDIS	Input	P7	84	<p>The active high transmit disable (TDIS) signal selectively disables overwriting each of the STS-1 or STS-3 (STM-1) streams with the corresponding overhead byte. TDIS is sampled on the rising edge of TICLK.</p> <p>TDIS is sampled on the rising edge of TCLK when multiplexing is bypassed, or when the bit serial STS-1 mode is selected. Note that TDIS takes precedence over the values shifted in on the transmit transport overhead interface (TTOH[4:1]) using TTOHEN.</p> <p>In general, the value on TIN[7:0] passes through transparently if TDIS is high. Three exceptions exist:</p> <ol style="list-style-type: none"> 1) Bits 6 to 8 of the K2 byte may be overwritten by an active FERF indication ("110") regardless of the state of TDIS. 2) If TDIS is high during the section BIP byte (B1), the TIN[7:0] value becomes an error mask for the generated section BIP. 3) If TDIS is high during the line BIP bytes (B2), the TIN[7:0] value becomes an error mask for the generated line BIP.

TTOH[4] TTOH[3] TTOH[2] TTOH[1]	Input	K14 M15 L14 N15	38 39 40 41	The transmit transport overhead bus (TTOH[4:1]) contains the transport overhead bytes (A1, A2, C1, E1, F1, D1-D3, H3, K1, K2, D4-D12, Z1, Z2, and E2) and error masks (H1, H2, B1, and B2) which may be inserted, or used to insert bit interleaved parity errors or payload pointer bit errors into the overhead byte positions in the outgoing stream. Insertion is controlled by the TTOHEN input. When STS-12/STM-4 mode is enabled, TTOH[1] contains the transport overhead for STS-3/STM-1 #1. TTOH[2] contains the transport overhead for STS-3/STM-1 #2. TTOH[3] contains the transport overhead for STS-3/STM-1 #3. TTOH[4] contains the transport overhead for STS-3/STM-1 #4. When STS-3/STM-1 mode or STS-1 mode are selected, TTOH[1] contains the transport overhead for the entire stream. TTOH[4:1] is sampled on the rising edge of TTOHCLK.
TTOHFP	Output	J13	36	The transmit transport overhead frame position (TTOHFP) signal is used to locate the individual transport overhead bits in the transport overhead bus, TTOH[4:1]. TTOHFP is set high while bit 1 (the most significant bit) of the first framing byte (A1) is expected in the incoming stream. TTOHFP is also used to mark the alignment of the TSUC, TSOW, TLOW, and TAPS bit streams. TTOHFP is updated on the falling edge of TTOHCLK.
TTOHCLK	Output	L15	35	The transmit transport overhead clock (TTOHCLK) is nominally a 5.184 MHz (1.728 MHz for STS-1) clock that provides timing for upstream circuitry that sources the transport overhead bus, TTOH[4:1]. TTOHCLK is a gapped 6.48 MHz clock when accessing the transport overhead of STS-3/STM-1 streams. TTOHCLK is a gapped 2.16 MHz clock when accessing the transport overhead of an STS-1 stream.

TTOHEN	Input	J12	37	<p>The transmit transport overhead insert enable (TTOHEN) signal controls the source of the transport overhead data which is inserted in the TOUT[7:0] stream. While TTOHEN is high (and TDIS is low), values sampled on the TTOH input are inserted into the corresponding transport overhead bit position (for the A1, A2, C1, E1, F1, D1-D3, H3, K1, K2, D4-D12, Z1, Z2, and E2 bytes). While TTOHEN is low, the default values are inserted into these transport overhead bit positions. A high level on TTOHEN during the H1, H2, B1, or B2 bit positions enables an error mask. While the error mask is enabled, a high level on inputs TTOH[4:1] causes the corresponding H1, H2, B1 or B2 bit positions to be inverted. A low level on TTOH allows the corresponding bit positions to pass through the STTX uncorrupted. TTOHEN is sampled on the rising edge of TTOHCLK.</p>
TFERF/ TRCPFP	Input	N4	99	<p>The active high transmit far end receive failure (TFERF) signal controls the insertion of a far end receive failure indication in the outgoing stream when the ring control port is disabled. When TFERF is set high, bits 6, 7, and 8 of the K2 byte are set to the pattern 110. Line FERF may also be inserted using the FERF bit in the TLOP Control Register, or upon detection of loss of signal, loss of frame, or line AIS in the receive stream, using the AUTOFERF bit in the Master Control/Enable Register. TFERF is sampled on the rising edge of TCLK.</p> <p>The transmit ring control port frame position (TRCPFP) signal identifies bit positions in the transmit ring control port data (TRCPDAT) when the ring control port is enabled (the enabling and disabling of the ring control port is controlled by a bit in the Master Control Register). TRCPFP is high during the filtered K1, K2 bit positions, the change of APS value bit position, the protection switch byte failure bit position, and the send AIS and send FERF bit positions in the TRCPDAT stream. TRCPFP is normally connected to the RRCPPF output of a mate STTX in ring-based add-drop multiplexer applications. TRCPFP is sampled on the rising edge of TRCPCLK.</p>

TLAIS/ TRCPDAT	Input	P2	100	<p>The active high transmit line alarm indication signal (TLAIS) controls the insertion of line AIS in the outgoing stream when the ring control port is disabled. When TLAIS is set high, the complete frame (except the section overhead or regenerator section) is overwritten with the all ones pattern (before scrambling). TLAIS is sampled on the rising edge of TCLK.</p> <p>The transmit ring control port data (TRCPDAT) signal contains the transmit ring control port data stream when the ring control port is enabled (the enabling and disabling of the ring control port is controlled by a bit in the Master Control Register). The transmit ring control port data consists of the filtered K1, K2 byte values, the change of APS value bit position, the protection switch byte failure status bit position, the send AIS and send FERF bit positions, and the line FEBE bit positions. TRCPDAT is normally connected to the RRCPCDAT output of a mate STTX in ring-based add-drop multiplexer applications. TRCPDAT is sampled on the rising edge of TRCPCCLK.</p>
TSDCLK	Output	P3	98	The transmit section DCC clock (TSDCLK) is a 192 kHz clock used to sample the TSD input. TSDCLK is generated by gapping a 216 kHz clock.
TSD	Input	P4	94	The transmit section DCC (TSD) signal contains the section data communications channel (D1, D2, D3) inserted into the outgoing stream. TSD is sampled on the rising edge of TSDCLK.
TOWCLK	Output	P6	89	The transmit order wire clock (TOWCLK) is a 64 kHz clock used to sample the TSOW, TSUC, and TLOW inputs. TOWCLK is generated by gapping a 72 kHz clock.
TSOW	Input	N7	86	The transmit section order wire (TSOW) signal contains the section order wire channel (E1) inserted into the outgoing stream. TSOW is sampled on the rising edge of TOWCLK.
TSUC	Input	M7	87	The transmit section user channel (TSUC) signal contains the section user channel (F1) inserted into the outgoing stream. TSUC is sampled on the rising edge of TOWCLK.

TLOW	Input	R5	85	The transmit line order wire (TLOW) signal contains the line order wire channel (E2) inserted into the outgoing stream. TLOW is updated on the rising edge of TOWCLK.
TLDCLK	Output	R2	93	The transmit line DCC clock (TLDCLK) is a 576 kHz clock used to sample the TLD input. TLDCLK is generated by gapping a 2.16 MHz clock.
TLD	Input	R3	92	The transmit line DCC (TLD) signal contains the line data communications channel (D4 - D12) inserted into the outgoing stream. TLD is sampled on the rising edge of TLDCLK.
TAPSCLK	Output	P5	91	The transmit automatic protection switch channel clock (TAPSCLK) is a 128 kHz clock used to sample the TAPS input. TAPSCLK is generated by gapping a 144 kHz clock.
TAPS	Input	R4	90	The transmit automatic protection switch channel (TAPS) signal carries the automatic protection switch channel (K1, K2) inserted into the outgoing stream. TAPS is sampled on the rising edge of TAPSCLK.
TOUT[7] TOUT[6] TOUT[5] TOUT[4] TOUT[3] TOUT[2] TOUT[1] TOUT[0]	Output	N3 R1 N2 P1 N1 L3 M2 L2	109 110 111 112 113 114 117 118	The transmit outgoing stream, (TOUT[7:0]), carries the scrambled STS-1, STS-3/STM-1, or STS-12/STM-4 stream in byte serial format. TOUT[7] is the most significant bit (corresponding to bit 1 of each serial PCM word, the first bit transmitted). TOUT[0] is the least significant bit (corresponding to bit 8 of each serial PCM word). TOUT[7:0] is updated on the rising edge of TCLK.
TSOUT	Output	M4	102	The transmit serial outgoing stream, (TSOUT), carries the scrambled stream in bit serial format when STS-1 mode is selected. TSOUT is updated on the rising edge of TSICLK.
TOFP	Output	M3	107	The active high transmit outgoing frame position (TOFP) signal is asserted once per frame in the byte position immediately following the C1 bytes in the outgoing stream. TOFP is updated on the rising edge of TCLK.

SCPO[5] SCPO[4] SCPO[3] SCPO[2] SCPO[1] SCPO[0]	Output Output Output Output Output Output		179 181 186 188 30 32	The serializer control port (SCPO[5:0]) is used to control the operation of the Serial Electrical Transmit Interface and the Serial Electrical Receive Interface chips. The signal levels on this output port correspond to the bit values contained in the Serializer Output Port Register. This control port is not available with the 180 pin CPGA packaging option.
SCPI[3] SCPI[2] SCPI[1] SCPI[0]	Input Input Input Input		128 130 76 78	The serializer status port (SCPI[3:0]) is used to monitor the operation of the Serial Electrical Transmit Interface and the Serial Electrical Receive Interface chips. An interrupt may be generated when state changes are detected in the monitored signals. State changes, and the real-time signal levels on this port are available in the Serializer Input Port Status/Value register. Each of the inputs contains an internal pull-down resistor. This status port is not available with the 180 pin CPGA packaging option.
INTB/ LINTB	Output	F15	19	The active low, open drain interrupt (INTB) signal is set when an event is detected on one of the STTX maskable interrupt sources, and the SLIM enable input (SLIM) is held low. The active low, open drain line interrupt (LINTB) signal is set when an event is detected on one of the line layer maskable interrupt sources, and the SLIM enable input (SLIM) is held high.
SINTB	Output		24	The active low, open drain section interrupt (SINTB) signal is set when an event is detected on one of the section layer maskable interrupt sources, and the SLIM enable input is held high. This interrupt signal is not available with the 180 pin CPGA packaging option.
A5/ SCSB	Input	C14	6	The most significant address signal (A5) is used in conjunction with the A[4:0] bus to access internal registers while the SLIM enable input is held low. The active low section chip select (SCSB) is used to select section layer register accesses while the SLIM enable input is held high.

A[4] A[3] A[2] A[1] A[0]	Input	B15 C15 E13 F12 F13	7 8 9 10 11	The address bus (A[4:0]) selects specific registers during accesses.
ALE	Input	D14	12	The address latch enable (ALE) signal latches the address bus (A[5:0]) when low. This allows the STTX to be interfaced to a multiplexed address/data bus. The address latches are transparent when ALE is high.
CSB/ LCSB	Input	E15	15	The active low chip select (CSB) signal is asserted during all register accesses while the SLIM enable input is a logic zero. The active low line chip select (LCSB) is used to select line layer register accesses while the SLIM enable input is a logic one.
D[7] D[6] D[5] D[4] D[3] D[2] D[1] D[0]	I/O	G13 G14 G15 H14 H13 H15 J15 K15	20 21 22 23 25 29 31 33	The bidirectional data bus, D[7:0], is used during STTX read and write accesses.
RDB	Input	G12	17	The active low read enable (RDB) signal is low during a STTX read access. The STTX drives the D[7:0] bus with the addressed register's contents while RDB and CSB are low.
WRB	Input	F14	16	The active low write strobe (WRB) signal is low during a STTX write access. The D[7:0] bus contents are clocked into the addressed register on the rising WRB edge while CSB is low.
RSTB	Input	E14	13	The active low reset (RSTB) signal is low to provide an asynchronous reset to the STTX. This schmitt triggered pin contains an internal pull up resistor.

SLIM	Input		27	The SLIM enable (SLIM) signal selects the format of the microprocessor bus. When SLIM is set to a logic one, the microprocessor bus is configured with two chip selects (SCSB, LCSB) to be backwards compatible with the SLIM-12. When SLIM is set to a logic zero, the microprocessor is configured with a single chip select, and an additional address pin (CSB, A5). The SLIM input contains an internal pull-down resistor. This control signal is not available with the 180 pin CPGA packaging option.
VDDI[0] VDDI[1] VDDI[2] VDDI[3]	Power Power Power Power	D10 K13 L8 F4	200 45 80 147	Core power pins (VDDI[3:0]). These pins must be connected to a common, well decoupled +5 VDC supply together with the VDDO[8:0] pins.
VSSI[0] VSSI[1] VSSI[2] VSSI[3]	Gnd Gnd Gnd Gnd	C10 K12 M8 F3	201 44 79 148	Core ground pins (VSSI[3:0]). These pins must be connected to a common ground together with the VSSO[9:0] pins.
VDDO[0] VDDO[1] VDDO[2] VDDO[3] VDDO[4] VDDO[5] VDDO[6] VDDO[7] VDDO[8]	Power Power Power Power Power Power Power Power Power	D5 D7 D9 H12 M6 K3 	159 173 193 26 95 116 133 88 183	Pad ring power pins (VDDO[8:0]). These pins must be connected to a common, well decoupled +5 VDC supply together with the VDDI[3:0] pins. Care must be taken to avoid coupling noise induced on the VDDO pins into the VDDI pins. VDDO[8:6] are not available with the 180 CPGA packaging option.
VSSO[0] VSSO[1] VSSO[2] VSSO[3] VSSO[4] VSSO[5] VSSO[6] VSSO[7] VSSO[8] VSSO[9]	Gnd Gnd Gnd Gnd Gnd Gnd Gnd Gnd Gnd Gnd	D6 E8 D11 H11 N6 L4 K4 J4 D4 	166 184 206 28 96 108 115 122 154 18	Pad ring ground pins (VSSO[9:0]). These pins must be connected to a common ground together with the VSSI[3:0] pins. Care must be taken to avoid coupling noise induced on the VSSO pins into the VSSI pins. VSSO[9] is not available with the 180 CPGA packaging option.

Notes on Pin Description:

1. VDDI and VSSI are the +5 V and ground connections, respectively, for the core circuitry of the device. VDDO and VSSO are the +5 V and ground connections, respectively, for the pad ring circuitry of the device. These power supply connections must all be utilized and must all connect to a common +5 V or ground rail, as appropriate. There is no low impedance connection within the STTX between the core and pad ring supply rails. Failure to properly make these connections may result in improper operation or damage to the device.
2. Inputs RSTB, and ALE have internal pull-up resistors.
3. Inputs RSIN, RSICLK, TSICLK, SLIM, and SCPI[3:0] have internal pull-down resistors.
4. Inputs SLIM, SCPI[3:0], and outputs SINTB, and SCPO[5:0] are not available with the 180 pin CPGA packaging option.
5. Most STTX digital outputs and bidirectionals have slew rate limited output drive capability, except the TSOUT, TOUT[7:0], and TOFP outputs which have 4 mA drive capability.

FUNCTIONAL DESCRIPTION

Serial to Parallel Converter

The Serial to Parallel Converter block provides the first stage of digital processing of an incoming receive STS-1 bit serial data stream when the STTX is configured for STS-1 operation. The byte alignment in the incoming stream is determined by searching for the 16 bit frame alignment signal (A1, A2). The bit serial stream (RSIN) is converted from serial to parallel format in accordance with the determined byte alignment. The Serial to Parallel Converter block is not used in STS-3/STM-1 or STS-12/STM-4 modes.

Receive Section Overhead Processor

The Receive Section Overhead Processor (RSOP) block processes the section overhead (regenerator section) of the receive incoming stream. It can be configured to process an STS-1, STS-3/STM-1, or STS-12/STM-4 data stream.

The RSOP block optionally descrambles the received data and extracts the data communication channel, order wire channel and user channel from the section overhead, and provides them as lower rate bit serial outputs (RSD, RSOW, RSUC) together with associated clock signals (RSDCLK, and ROWCLK). The complete descrambled SONET/SDH data stream is output by the STTX in byte serial format. Line alarm indication signal is inserted in the byte serial output data stream using input RLAIS or, optionally, automatically when loss-of-frame, or loss-of-signal events occur. The automatic insertion of AIS is controlled by the AUTORAIS bit in the Ring Control Register.

Out-of-frame (OOF), loss-of-frame (LOF), and loss-of-signal (LOS) state outputs are provided and section level bit-interleaved parity errors are accumulated. A section BIP-8 error clock is also provided (B1E). A maskable interrupt is activated by state transitions on the OOF, LOF, or LOS outputs, or by a single B1 error event. Microprocessor readable registers are provided that allow accumulated B1 errors to be read out at intervals of up to one second duration.

The RSOP block frames to the data stream by operating with an upstream pattern detector (the Serial to Parallel Converter block for STS-1 streams; or an external serial to parallel converter for STS-3/STM-1 or STS-12/STM-4 streams) that searches for occurrences of the framing pattern (A1, A2) in the bit serial data stream.

Once the external serial to parallel converter has found byte-alignment, the RSOP block monitors for the next occurrence of the framing pattern 125 μ s later. The block declares frame alignment when either all A1 and A2 bytes are seen error-free or when only the first A1 byte and the first four bits of the A2 byte are seen error-free. Depending upon the operating mode, the first algorithm examines 2 bytes (A1,A2) in STS-1 mode, 6 bytes (A1A1A1,A2A2A2) in STS-3/STM-1 mode, or 24 bytes

(A1A1A1A1A1A1 A1A1A1A1A1A1, A2A2A2A2A2A2A2A2A2A2A2) in STS-12/STM-4 mode.

The second algorithm examines only the first occurrence of A1 and the first four bits of the first occurrence of A2 in the sequence, regardless of the operating mode. Once in frame, the RSOP block monitors the framing pattern sequence and declares OOF when one or more bit errors in each framing pattern are detected for four consecutive frames. Again, depending upon the operating mode selected the first algorithm examines all 2, 6, or 24 framing bytes for bit errors each frame, while the second algorithm examines only the A1 byte and the first four bits of the A2 byte (i.e. 12 bits total) during each frame.

The performance of these framing algorithms in the presence of bit errors and random data is robust. When looking for frame alignment the performance of each algorithm is dominated by the alignment algorithm used in the external receive interface for the STS-3/STM-1 and STS-12/STM-4 operating modes. Typical probability of falsely framing to random data is less than 0.00001% for either algorithm.

When the STTX is operating in STS-1 mode either algorithm still provides less than 0.00001% probability of falsely framing to random data. Once in frame alignment, the STTX continuously monitors the framing pattern. When the incoming stream contains a 10^{-3} BER, the first algorithm provides a 99.75% probability that the mean time between OOF occurrences is 4 minutes in STS-1 mode, 14 seconds in STS-3/STM-1 mode, and 1.3 seconds in STS-12/STM-4 operating mode. The second algorithm provides a 99.75% probability that the mean time between OOF occurrences is 7 minutes, regardless of operating mode.

The RSOP block provides descrambled data and frame alignment indication signals for use by the Receive Line Overhead Processor.

Receive Line Overhead Processor

The Receive Line Overhead Processor block (RLOP) processes the line overhead (multiplexer section) of a received SONET/SDH data stream. It can be configured to process an STS-1, STS-3/STM-1, or STS-12/STM-4 data stream that is presented in byte serial format at the STS-N frame rate of 6.48 Mbyte/s, 19.44 Mbyte/s, or 77.76 Mbyte/s respectively.

The STS-N frame is indicated by the Receive Section Overhead Processor. The RLOP extracts the line data communication channel, line order wire channel and automatic protection switch channel from the line overhead, and provides them as lower rate bit serial outputs (RLD, RLOW, RAPS) together with associated clock signals (RLDCLK, ROWCLK, RAPSCLK).

Line alarm indication signal is declared (LAIS is set high) when the bit pattern 111 is observed in bits 6, 7, and 8 of the K2 byte for three or five consecutive frames. Line

AIS is removed when any pattern other than 111 is observed for three or five consecutive frames.

Line far end receive failure, is declared (FERF is set high) when the bit pattern 110 is observed in bits 6, 7, and 8 of the K2 byte for three or five consecutive frames. Line FERG is removed when any pattern other than 110 is observed for three or five consecutive frames.

The automatic protection switch bytes (K1, K2) are also extracted into the Receive K1 Register and the Receive K2 Register. The bytes are filtered for three frames before being written to these registers. A protection switching byte failure alarm is declared when twelve successive frames have been received, where no three consecutive frames contain identical K1 bytes. The protection switching byte failure alarm is removed upon detection of three consecutive frames containing identical K1 bytes. The detection of invalid APS codes is done in software by polling the Receive K1/K2 Registers

The line level bit-interleaved parity (B2) is computed, and compared to the received B2 bytes. Line BIP-8 errors are accumulated in an internal counter. Registers are provided that allow accumulated line BIP-8 errors to be read out at intervals of up to one second duration. A line BIP-8 error clock is also provided (B2E).

The line level far end block error byte (the third Z2 byte in the STS-3 or STS-12 stream, or the single Z2 byte in the STS-1 stream) is extracted and accumulated in an internal counter. Registers are provided that allow accumulated line FEBE events to be read out at intervals of up to one second duration. Bits 2 through 8 of the Z2 byte are used for the line FEBE function. For STS-1 streams, the line FEBE byte has 9 legal values (namely 00H - 08H) representing 0 to 8 FEBE events. For STS-3 streams, the line FEBE byte has 25 legal values (namely 00H - 18H) representing 0 to 24 FEBE events. For STS-12 streams, the line FEBE byte has 97 legal values (namely 00H - 60H) representing 0 to 96 errors. Illegal Z2 values are interpreted as zero errors.

An interrupt output is provided that may be activated by declaration or removal of line AIS, line FERG, protection switching byte failure alarm, a change of APS code value, a single B2 error event, or a single line FEBE event. Each interrupt source is individually maskable.

Byte Interleaved Demultiplexer

The Byte Interleaved Demultiplexer block (BIDX) performs a 1:3 (STS-3 to STS-1), or a 1:4 (STS-12 or STM-4 to STS-3 or STM-1) demultiplexing function on the incoming byte serial STS-3, or STS-12/STM-4 data stream. The demultiplexed streams are available on the four byte wide busses: ROUT1[7:0], ROUT2[7:0], ROUT3[7:0], and ROUT4[7:0]. The frame position of these aligned streams is located by the ROFP signal. ROCLK may be used by downstream circuitry to

process the synchronous payload envelope(s) contained in the byte serial demultiplexed streams.

The demultiplexer function in this block may be bypassed using the DXB bit in the Master Configuration Register, in which case the byte serial receive stream is available on ROUT1[7:0].

Receive Transport Overhead Access

The Receive Transport Overhead Access block (RTOH) extracts the entire receive transport overhead on the RTOH[4:1] bus, along with the 5.184 MHz (or 1.728 MHz) transport overhead clock, RTOHCLK, and the transport overhead frame position, RTOHFP, allowing identification of the bit positions in the transport overhead stream.

Ring Control Port

The Transmit and Receive Ring Control Ports provide bit serial access to section and line layer alarm and maintenance signal status and control. These ports are useful in ring-based add drop multiplexer applications where alarm status and maintenance signal insertion control must be passed between separate STTXs (possibly residing on separate cards). Each ring control port consists of three signals: clock, data and frame position. It is intended that the clock, data and frame position outputs of the receive ring control port are connected directly to the clock, data and frame position inputs of the transmit ring control port on the mate STTX. The alarm status and maintenance signal control information that is passed on the ring control ports consists of

- Filtered APS (K1 and K2) byte values
- Change of filtered APS byte value status
- Protection switch byte failure alarm status
- Change of protection switch byte failure alarm status
- Insert the line FERF maintenance signal in the mate STTX
- Insert the line AIS maintenance signal in the mate STTX
- Insert line FEBE information in the mate STTX.

The same APS byte values must be seen for three consecutive frames before being shifted out on the receive ring control port. The change of filtered APS byte value status is high for one frame when a new, filtered APS value is shifted out.

The protection switch byte failure alarm bit position is high when twelve consecutive frames, where no three consecutive frames contain identical K1 bytes have been received. The bit position is set low when three consecutive frames containing identical K1 bytes have been received. The change of protection switch byte failure alarm status bit position is set high for one frame when the alarm state changes.

The insert line FERF bit position is set high under register control, or when loss of signal, loss of frame, or line AIS alarms are declared. The insert line AIS bit position is set high under register control only.

The insert line FEBE bit positions are high for one bit position for each detected B2 bit error. Up to 96 FEBEs may be indicated per frame for an STS-12/STM-4 signal.

Transmit Transport Overhead Access

The Transmit Transport Overhead Access block (TTOH) allows the complete transport overhead to be inserted using the TTOH[4:1] bus, along with the 5.184 MHz (or 1.728 MHz) transport overhead clock, TTOHCLK, and the transport overhead frame position, TTOHFP. The transport overhead enable signal, TTOHEN, controls the insertion of transport overhead from the TTOH[4:1] bus. The STTX also supports upstream insertion of the line overhead using the TDIS input. TDIS is used to disable the insertion of transport overhead either from the TTOH[4:1] bus, or from the individual channels (TSD, TSOW, TSUC, TLD, TAPS, and TLOW).

Byte Interleaved Multiplexer

The Byte Interleaved Multiplexer block (BIMX) performs a 3:1 (STS-1 to STS-3), or a 4:1 (STS-3/STM-1 to STS-12/STM-4) multiplexing function on incoming byte serial STS-1, or STS-3/STM-1 data streams. The multiplexed inputs are contained on the four byte wide busses: TIN1[7:0], TIN2[7:0], TIN3[7:0], and TIN4[7:0]. The transport overhead of these frame aligned streams is determined by the TIFP input. The resulting multiplexed byte serial stream is passed to the Transmit Line Overhead Processor from which the line overhead (multiplexer section) is added to the stream.

The multiplexer function in this block may be bypassed using the MXB bit in the Master Configuration Register, in which case the TIN1[7:0] stream is passed directly to the Transmit Line Overhead Processor.

The lower rate STS-1 or STS-3 (STM-1) clock (TICLK) is synchronous with, but arbitrarily phase aligned to the higher rate STS-3/12 clock (TCLK). A lower rate internal sampling clock is derived by dividing TCLK by three or four, as appropriate. A phase alignment error is declared when the sampling clock phase, and the TICLK clock phase are identical. The sampling clock phase is modified during a phase alignment error to provide a safe phase relationship between the sampling clock, and TICLK, thus ensuring the robust operation of co-directional timing-based systems. A maskable interrupt output is provided that may be activated by a phase alignment error event.

A generated transmit clock (GTICLK) is provided for use in contra-directional timing-based systems. In such systems, GTICLK is connected directly to TICLK, and also to upstream circuitry from which the low speed tributary streams (TIN1-TIN4) are "pulled".

Transmit Line Overhead Processor

The Transmit Line Overhead Processor block (TLOP) processes the line overhead of the transmit stream. It can be configured to process an STS-1, STS-3 (STM-1), or STS-12 (STM-4) data stream that is presented in byte serial format at the rate of 6.48 Mbyte/s, 19.44 Mbyte/s, or 77.76 Mbyte/s respectively.

The TLOP optionally inserts the line data communication channel, the line order wire channel, and the automatic protection switch channel into the line overhead of the STS-N data stream. These line overhead channels are separately fed to the TLOP as bit serial inputs (TLD, TLOW, and TAPS). The TLOP provides the bit serial clock for each line overhead channel (TLDCLK, TOWCLK, TAPSCCLK).

Line FERF may be inserted in the SONET/SDH stream under the control of an external input (TFERF), or a writeable register. The AUTOFERF bit in the Ring Control Register controls the immediate insertion of Line FERF upon detection of Line AIS in the received SONET/SDH stream.

Line FEBE may be inserted automatically in the SONET/SDH stream under the control of the AUTOFEBE bit in the Ring Control Register. Receive B2 errors are accumulated and inserted automatically in bits 2 to 8 of the third Z2 byte of the transmit stream (for STS-3/STM-1 and STS-12/STM-4 modes only). B2 errors are accumulated and inserted in the Z2 byte of the transmit stream for STS-1 mode. Up to 8 (24, or 96) errors may be inserted per frame for STS-1 (STS-3 or STS-12-12) mode.

The line BIP (B2) error detection code for the STS-N stream is calculated by the TLOP and is inserted into the line overhead. Errors may be inserted in the B2 code for diagnostic purposes. A byte serial STS-N stream, along with a frame position indicator is passed to the Transmit Section Overhead Processor.

Transmit Section Overhead Processor

The Transmit Section Overhead Processor (TSOP) block processes the section overhead of the transmit stream. It can be configured to process an STS-1, STS-3/STM-1, or STS-12/STM-4 data stream that is presented in byte serial format at 6.48 Mbyte/s, 19.44 Mbyte/s, or 77.76 Mbyte/s respectively.

The TSOP accepts an unscrambled stream in byte serial format from the Transmit Line Overhead Processor. It optionally inserts the section data communication channel, the order wire channel, and the user channel into the section overhead (regenerator section) of the stream. These section overhead channels are input to the STTX as bit serial signals (TSD, TSOW, and TSUC). The TSOP provides the bit serial clock for each section overhead channel (TSDCLK, and TOWCLK). The line alarm indication signal may optionally be inserted into the data stream under the control of an external input (TLAIS), or a microprocessor writeable register.

The section BIP-8 error detection code (B1) is calculated by the TSOP block and is inserted into the section (regenerator section) overhead of the SONET (SDH) data stream. Errors may be inserted in the B1 code for diagnostic purposes. Framing and identity bytes are also inserted. Finally, the complete SONET/SDH data stream is scrambled and output by the TSOP in byte serial format on outputs TOUT[7:0].

The TSOP block is intended to operate with a downstream serializer (the Parallel to Serial Converter block for STS-1 streams; or external Parallel to Serial converters for STS-3/STM-1 or STS-12/STM-4 streams) that accepts the transmit stream in byte serial format and serializes it at the appropriate line rate.

Parallel to Serial Converter

The Parallel to Serial Converter block provides the final stage of digital processing for the transmit STS-1 data stream. This block converts the data stream from parallel to serial format.

The byte serial STS-1 clock (TCLK) is synchronous with, but arbitrarily phase aligned to the bit serial STS-1 clock (TSICLK). A lower rate internal sampling clock is derived by dividing TSICLK by eight. A phase alignment error is declared when the sampling clock phase, and the TCLK clock phase are identical. The sampling clock phase is modified during a phase alignment error to provide a safe phase relationship between the sampling clock, and TCLK, thus ensuring the robust operation of co-directional timing-based systems. A maskable interrupt output is provided that may be activated by a phase alignment error event.

A generated transmit clock (GTICLK) is provided for use in contra-directional timing-based systems. In such systems, GTICLK is connected directly to TCLK, and also to upstream circuitry from which the byte serial STS-1 stream (TIN1) is "pulled".

Microprocessor Interface

The Microprocessor Interface Block provides the logic required to interface the normal mode and test mode registers within the STTX to a generic microprocessor bus. The normal mode registers are used during normal operation to configure and monitor the STTX while the test mode registers are used to enhance the testability of the STTX.

REGISTER DESCRIPTION**Normal Mode Register Memory Map**

SLIM=0	SLIM=1		Register	
A[5:0]	SCSB	LCSB	A[4:0]	
00H	1	0	00H	Master Configuration
01H	1	0	01H	Master Control/Enable
02H	1	0	02H	Master Interrupt Status
03H	1	0	03H	Master Reset and Identity
04H	1	0	04H	TLOP Control
05H	1	0	05H	TLOP Diagnostic
06H	1	0	06H	Transmit K1
07H	1	0	07H	Transmit K2
08H	1	0	08H	RLOP Control/Status
09H	1	0	09H	RLOP Interrupt
0AH	1	0	0AH	B2 Error Count #1
0BH	1	0	0BH	B2 Error Count #2
0CH	1	0	0CH	B2 Error Count #3
0DH	1	0	0DH	FEBE Error Count #1
0EH	1	0	0EH	FEBE Error Count #2
0FH	1	0	0FH	FEBE Error Count #3
10H	0	1	00H	RSOP Control
11H	0	1	01H	RSOP Interrupt Status
12H	0	1	02H	B1 Error Count #1
13H	0	1	03H	B1 Error Count #2
14H	0	1	04H	Serializer Output Port
15H	0	1	05H	Serializer Input Port Enable
16H	0	1	06H	BIMX Interrupt
17H	0	1	07H	Ring Control Port
18H	0	1	08H	TSOP Control
19H	0	1	09H	TSOP Diagnostic

1AH	0	1	0AH	Transmit Z1
1BH	0	1	0BH	Receive Z1
1CH	0	1	0CH	PISO Interrupt
1DH	0	1	0DH	Receive K1
1EH	0	1	0EH	Receive K2
1FH	0	1	0FH	Serializer Input Port Status/Value
20H-2FH	0	1	10-1FH	Reserved for line layer test
30H-3FH	1	0	10-1FH	Reserved for section layer test

Registers are used to configure, and monitor the operation of the STTX

Notes on Register Bits:

1. Writing values into unused register bits has no effect. However, to ensure software compatibility with future, feature-enhanced versions of the product, unused register bits must be written with logic zero. Reading back unused bits can produce either a logic one or a logic zero; hence unused register bits should be masked off by software when read.
2. All configuration bits that can be written into can also be read back. This allows the processor controlling the STTX to determine the programming state of the block.
3. Writeable normal mode register bits are cleared to logic zero upon reset unless otherwise noted.
4. Writing into read-only normal mode register bit locations does not affect STTX operation unless otherwise noted.
5. Certain register bits are reserved. These bits are associated with megacell functions that are unused in this application. To ensure that the STTX operates as intended, reserved register bits must only be written with logic zero. Similarly, writing to reserved registers should be avoided.

Address 00H Master Configuration

Bit	Type	Function	Default
Bit 7	R/W	TMODE[1]	1
Bit 6	R/W	TMODE[0]	1
Bit 5	R/W	FPOS/STS1	0
Bit 4	R/W	DXBP	0
Bit 3	R/W	MXBP	0
Bit 2	R/W	MODESEL	0
Bit 1	R/W	RMODE[1]	1
Bit 0	R/W	RMODE[0]	1

RMODE[1:0]:

The RMODE[1:0] bus selects the operating mode of the receive overhead processor, as follows:

RMODE[1:0]	MODE
00	STS-1
01	STS-3 (STM-1)
10	Reserved
11	STS-12 (STM-4)

The BIDX block is bypassed when STS-1 mode is selected. BIDX is configured as a 1:3 demultiplexer when STS-3 (STM-1) mode is selected. BIDX is configured as a 1:4 demultiplexer when STS-12 (STM-4) mode is selected. BIDX may also be bypassed while in STS-3 or STS-12 modes using the DXB bit. When the MODESEL bit is a logic zero, RMODE[1:0] also controls the mode selection for the transmit overhead processor.

MODESEL:

The MODESEL bit controls the operation of the transmit and receive mode selection bits, TMODE[1:0] and RMODE[1:0]. When MODESEL is set to logic one, TMODE[1:0] selects the STTX transmit operating mode, and RMODE[1:0] selects the STTX receive operating mode (the receive and transmit operating modes may be selected independently). When MODESEL is set to logic zero, RMODE[1:0] selects the operating mode for the receive and transmit directions (the receive and transmit directions must operate in the same mode).

MXBP:

The MXBP bit controls the bypassing of the multiplexer block. When MXBP is set to a logic zero, the multiplexer block is enabled, and the three or four byte serial input streams are multiplexed to a single byte serial stream before the

line overhead is inserted. When MXBP is set to a logic one, the multiplexer block is bypassed, and one byte serial input stream is processed.

DXBP:

The DXBP bit controls the bypassing of the demultiplexer block. When DXBP is set to a logic zero, the demultiplexer block is enabled, and the byte serial input stream is demultiplexed into three or four byte serial output streams. When DXBP is set to a logic one, the demultiplexer block is bypassed, and a single byte serial stream is output.

FPOS/STS1:

When receive STS-3, or STS-12 modes are selected, the FPOS/STS1 bit controls receive interface of the STTX. When FPOS/STS1 is a logic zero, the receive incoming frame position (RIFP) is expected during the third A2 byte of the receive incoming stream (RIN[7:0]). When FPOS/STS1 is a logic one, the receive incoming frame position is indicated during the byte position immediately following the C1 bytes in the receive incoming stream.

When receive STS-1 mode is selected, the FPOS/STS1 bit selects the STS-1 receive interface type. When FPOS/STS1 is a logic zero, the bit serial, 51.84 Mbit/s interface (using RSIN) is selected. When FPOS/STS1 is a logic one, the byte serial, 6.48 Mbyte/s interface (using RIN[7:0]) is selected. When the byte serial STS-1 stream is enabled, the incoming frame position is indicated during the byte position immediately following the C1 byte in the receive stream.

TMODE[1:0]:

The TMODE[1:0] bus selects the operating mode of the transmit overhead processor, when the MODESEL bit is set to a logic one, as follows:

TMODE[1:0]	MODE
00	STS-1
01	STS-3 (STM-1)
10	Reserved
11	STS-12 (STM-4)

The BIMX block is bypassed when STS-1 mode is selected. BIMX is configured as a 1:3 multiplexer when STS-3 (STM-1) mode is selected. BIDX is configured as a 1:4 multiplexer when STS-12 (STM-4) mode is selected. BIMX may also be bypassed while in STS-3 or STS-12 modes using the MXB bit. The TMODE[1:0] value is ignored when the MODESEL bit is set to a logic zero.

Address 01H
Master Control/Enable

Bit	Type	Function	Default
Bit 7	R/W	RCP	0
Bit 6	R/W	Z1E	0
Bit 5	R/W	PSBFE	0
Bit 4	R/W	COAPSE	0
Bit 3	R/W	PISOE	0
Bit 2	R/W	RSOPE	0
Bit 1	R/W	BIMXE	0
Bit 0	R/W	RLOPE	0

RLOPE:

The RLOP interrupt enable is an interrupt mask for events detected by the receive line overhead processor. When RLOPE is a logic one, an interrupt is generated when line layer events are detected by the RLOP.

BIMXE:

The BIMX interrupt enable is an interrupt mask for events detected by the byte interleaved multiplexer. When BIMXE is a logic one, an interrupt is generated when phase alignment errors are detected by the BIMX.

RSOPE:

The RSOP interrupt enable is an interrupt mask for events detected by the receive section overhead processor. When RSOPE is a logic one, an interrupt is generated when section layer events are detected by the RSOP.

PISOE:

The PISO interrupt enable is an interrupt mask for events detected by the STS-1 parallel to serial converter. When PISOE is a logic one, an interrupt is generated when phase alignment errors are detected by the PISO.

COAPSE:

The change of APS byte interrupt enable is an interrupt mask for events detected by the receive APS processor. When COAPSE is a logic one, an interrupt is generated when a new K1/K2 code value has been extracted into the Receive K1/K2 Registers.

PSBFE:

The change of protection switch byte failure alarm interrupt enable is an interrupt mask for events detected by the receive APS processor. When PSBFE is a logic one, an interrupt is generated upon a change in the protection switch byte failure alarm state.

Z1E:

The change of Z1 interrupt enable is an interrupt mask for changes in the receive Z1 byte value. When Z1E is a logic one, an interrupt is generated when the extracted Z1 byte is different from the Z1 byte extracted in the previous frame.

RCP:

The RCP bit controls the enabling of the receive and transmit ring control ports. When RCP is a logic zero, the ring control ports are disabled, and the LOS, LAIS and FERF outputs and the RLAIS, TLAIS, and TFERF inputs are used to monitor alarm status and control maintenance signal insertion. When RCP is a logic one, the ring control ports are enabled, and alarm status and maintenance signal insertion control is provided by the RRCPCCLK, RRCPPFP, and RRCPPDAT outputs and the TRCPCCLK, TRCPPFP, and TRCPCDAT inputs.

Address 02H**Master Interrupt Status**

Bit	Type	Function	Default
Bit 7	R	PSBFV	X
Bit 6	R	Z1I	X
Bit 5	R	PSBFI	X
Bit 4	R	COAPSI	X
Bit 3	R	PISOI	X
Bit 2	R	RSOPI	X
Bit 1	R	BIMXI	X
Bit 0	R	RLOPI	X

RLOPI:

The RLOPI bit is set high when one or more of the maskable interrupt sources in the receive line overhead processor has been activated. This register bit remains high until the interrupt is acknowledged by reading the RLOP Interrupt Enable and Status Register.

BIMXI:

The BIMXI bit is high when the maskable phase alignment error interrupt source in the byte interleaved multiplexer has been activated. This register bit remains active until the interrupt is acknowledged by reading the BIMX Interrupt Enable and Status Register.

RSOPI:

The RSOPI bit is set high when one or more of the maskable interrupt sources in the receive section overhead processor has been activated. This register bit remains high until the interrupt is acknowledged by reading the RSOP Interrupt Status Register.

PISOI:

The PISOI bit is high when the maskable phase alignment error interrupt source in the parallel to serial converter has been activated. This register bit remains active until the interrupt is acknowledged by reading the PISO Interrupt Register.

COAPSI:

The COAPSI bit is set high when a new APS code value has been extracted into the Receive K1/K2 Registers. The registers are updated when the same new K1/K2 byte values are observed for three consecutive frames. This bit is cleared when the Master Interrupt Status Register is read.

PSBFI:

The PSBFI bit is set high when the protection switching byte failure alarm is

declared or removed. This bit is cleared when the Master Interrupt Status Register is read.

Z1I:

The Z1I bit is set high when a new Z1 byte value has been extracted into the Receive Z1 Register. The register is updated when a Z1 byte value is extracted that is different than the Z1 byte value extracted in the previous frame. This bit is cleared when the Master Interrupt Status Register is read.

PSBFV:

The PSBFV bit indicates the protection switching byte failure alarm state. The alarm is declared (PSBFV is set high) when twelve successive frames, where no three consecutive frames contain identical K1 bytes, have been received. The alarm is removed (PSBFV is set low) when three consecutive frames containing identical K1 bytes have been received.

Address 03H
Master Reset and Identity

Bit	Type	Function	Default
Bit 7	RW	RESET	0
Bit 6	R	RICLKA	0
Bit 5	R	TCLKA	0
Bit 4	R	TICLKA	0
Bit 3	R	RINA	0
Bit 2	R	ID[2]	0
Bit 1	R	ID[1]	0
Bit 0	R	ID[0]	1

A write to this register initiates a transfer of all performance monitor counter values (B1, B2, and line FEBE) into holding registers.

ID[2:0]:

The version identification bits ID[2:0], are set to the value 1H, representing the version number of the STTX.

RINA:

The receive bus activity monitor bit is set to a logic one if one or more transitions are detected on primary inputs RIN[7:0] and RIFP since the last time this register was read. A logic 0 in this bit position indicates a stuck-at fault exists between the RIN[7:0] or RIFP inputs, and the upstream serial to parallel converter circuit.

TICLKA:

The low speed transmit clock activity monitor is set to a logic one if one or more transitions are detected on primary input TICLK since the last time this register was read. A logic 0 in this bit position indicates TICLK is not toggling.

TCLKA:

The transmit clock activity monitor is set to a logic one if one or more transitions are detected on primary input TCLK since the last time this register was read. A logic 0 in this bit position indicates TCLK is not toggling.

RICLKA:

The receive clock activity monitor is set to a logic one if one or more transitions are detected on primary input RICLK since the last time this register was read. A logic 0 in this bit position indicates RICLK is not toggling.

RESET:

The RESET bit allows the STTX to be asynchronously reset. The software reset is equivalent to setting the RSTB input pin low. When RESET is a logic one, the STTX is reset. When RESET is a logic zero, the reset is removed. The RESET bit must be explicitly set and cleared by writing the corresponding logic value to this register.

Address 04H
TLOP Control

Bit	Type	Function	Default
Bit 7		Unused	X
Bit 6	R/W	UBT	0
Bit 5	R/W	APSREG	0
Bit 4	R/W	DGROWTH	0
Bit 3	R/W	DAPS	0
Bit 2	R/W	DDL	0
Bit 1	R/W	DOW	0
Bit 0	R/W	FERF	0

FERF:

The FERF bit controls the insertion of transmit line far end receive failure (FERF). When FERF is a logic one, line FERF is inserted into the SONET/SDH stream on TOUT[7:0]. Line FERF is inserted by transmitting the code 110 in bit positions 6, 7, and 8 of the K2 byte. Line FERF may also be inserted using the TFERF input (when the ring control ports are disabled) or using the transmit ring control port (when it is enabled). When FERF is logic zero, bit 6, 7, and 8 of the K2 byte are not modified by the transmit line overhead processor.

DOW:

The DOW bit controls the overwriting of the express orderwire byte (E2). When DOW is logic one, the value sampled on TIN1[7:0] during the E2 byte position is passed through the transmit line overhead processor unaltered, as though the TDIS input had been sampled high during the E2 byte position in the incoming frame. The upstream insertion of the express orderwire is thus accomplished without the use of the TDIS input. Note that only the E2 byte position is passed unaltered, the remaining 2 (STS-3/STM-1) or 11 (STS-12/STM-4) undefined byte positions are overwritten with all zeros. This overwriting may be defeated by using the TDIS input, or by using the UBT bit in this register. When DOW is logic zero, the express order wire source is nominally the TLOW input (while TDIS and TTOHEN are both low).

DDL:

The DDL bit controls the overwriting of the line data communications channel (D4 - D12). When DDL is logic one, the values sampled on TIN1[7:0] during the D4 - D12 byte positions are passed through the transmit line overhead processor unaltered, as though the TDIS input had been sampled high during the D4 - D12 byte positions in the incoming frame. The upstream insertion of the line DCC is thus accomplished without the use of the TDIS input. Note that only the D4 - D12 byte positions are passed unaltered, the remaining 18 (STS-3/STM-1) or 99 (STS-12/STM-4) undefined byte positions are

overwritten with all zeros. This overwriting may be defeated by using the TDIS input, or by using the UBT bit in this register. When DDL is logic zero, the line DCC source is nominally the TLD input (while TDIS and TTOHEN are both low).

DAPS:

The DAPS bit controls the overwriting of the automatic protection switch channel (K1, K2). When DAPS is logic one, the values sampled on TIN1[7:0] during the K1 and K2 byte positions are passed through the transmit line overhead processor unaltered, as though the TDIS input had been sampled high during the K1 and K2 byte positions in the incoming frame. The upstream insertion of the APS channel is thus accomplished without the use of the TDIS input. Note that only the K1 and K2 byte positions are passed unaltered, the remaining 4 (STS-3/STM-1) or 22 (STS-12/STM-4) undefined byte positions are overwritten with all zeros. This overwriting may be defeated by using the TDIS input, or by using the UBT bit in this register. When DAPS is logic zero, the APS source is nominally the TAPS input or the Transmit K1/K2 Registers (as selected by the APSREG bit in the TLOP Control Register while TDIS and TTOHEN are both low).

DGROWTH:

The DGROWTH bit controls the overwriting of the growth bytes (Z1, Z2). When DGROWTH is logic one, the values sampled on TIN1[7:0], TIN2[7:0], TIN3[7:0], and TIN4[7:0] during the growth byte positions, except for the first Z1 byte, are passed through the transmit line overhead processor unaltered, as though the TDIS input had been sampled high during the growth byte positions in the incoming frame. The first Z1 byte is always sourced from the Transmit Z1 register (Register 1AH). The upstream insertion of the growth bytes is thus accomplished without the use of the TDIS input. Note that 5 (STS-3/STM-1) or 23 (STS-12/STM-4) growth bytes are passed through unaltered. When DGROWTH is logic zero, the growth byte positions are nominally overwritten with the line FEBE value, the transmit Z1 value and all zeros (while TDIS and TTOHEN are both low).

APSREG:

The APSREG bit selects the source for the transmit APS channel. When APSREG is a logic zero, the transmit APS channel is inserted from the bit serial input TAPS which is shifted in on the rising edge of TAPCLK. When APSREG is a logic one, the transmit APS channel is inserted from the Transmit K1 Register and the Transmit K2 Register. The APS bytes may also be inserted upstream of the TLOP using the TDIS or TTOHEN inputs, or the DAPS bit in the TLOP Control Register. Values inserted using TDIS take precedence over the source selected by the APSREG bit.

UBT:

The UBT bit controls the overwriting of the unused byte positions in the transmit STS-3, or STS-12 stream. The unused bytes are contained in the

K1, K2, D4-D12, and E2 byte positions of STS-1 #2 to N (N=3, or 12). When UBT is logic zero, the unused byte position are overwritten with all zeros. When UBT is logic one, the values sampled on TIN1[7:0], TIN2[7:0], TIN3[7:0], and TIN4[7:0] during the unused byte positions are passed through the transmit line overhead processor unaltered, as though the TDIS input had been sampled high during the unused byte positions in the incoming frame.

Address 05H
TLOP Diagnostic

Bit	Type	Function	Default
Bit 7		Unused	X
Bit 6		Unused	X
Bit 5		Unused	X
Bit 4		Unused	X
Bit 3		Unused	X
Bit 2		Unused	X
Bit 1		Unused	X
Bit 0	R/W	DB2	0

DB2:

The DB2 bit controls the insertion of bit errors continuously in each of the line BIP-8 bytes (B2 bytes). When DB2 is set high, each bit of every B2 byte is inverted.

Address 06H
Transmit K1

Bit	Type	Function	Default
Bit 7	RW	K1[7]	0
Bit 6	RW	K1[6]	0
Bit 5	RW	K1[5]	0
Bit 4	RW	K1[4]	0
Bit 3	RW	K1[3]	0
Bit 2	RW	K1[2]	0
Bit 1	RW	K1[1]	0
Bit 0	RW	K1[0]	0

K1[7:0]:

The K1[7:0] bits contain the value inserted in the K1 byte when the APSREG bit in the TLOP Control Register is logic one. K1[7] is the most significant bit corresponding to bit 1, the first bit transmitted. K1[0] is the least significant bit, corresponding to bit 8, the last bit transmitted. The bits in this register are double buffered so that register writes do not need to be synchronized to SONET/SDH frame boundaries. The insertion of a new APS code value is initiated by a write to this register. The contents of this register, and the Transmit K2 Register are inserted in the SONET/SDH stream starting at the next frame boundary. Successive writes to this register must be spaced at least two frames (250 μ s) apart.

Address 07H
Transmit K2

Bit	Type	Function	Default
Bit 7	RW	K2[7]	0
Bit 6	RW	K2[6]	0
Bit 5	RW	K2[5]	0
Bit 4	RW	K2[4]	0
Bit 3	RW	K2[3]	0
Bit 2	RW	K2[2]	0
Bit 1	RW	K2[1]	0
Bit 0	RW	K2[0]	0

K2[7:0]:

The K2[7:0] bits contain the value inserted in the K2 byte when the APSREG bit in the TLOP Control Register is logic one. K2[7] is the most significant bit corresponding to bit 1, the first bit transmitted. K2[0] is the least significant bit, corresponding to bit 8, the last bit transmitted. The bits in this register are double buffered so that register writes do not need to be synchronized to SONET/SDH frame boundaries. The insertion of a new APS code value is initiated by a write to the Transmit K1 Register. A coherent APS code value is ensured by writing the desired K2 APS code value to this register before writing the Transmit K1 Register.

Address 08H
RLOP Control/Status

Bit	Type	Function	Default
Bit 7	RW	BIPWORD	0
Bit 6	RW	ALLONES	0
Bit 5	RW	AISDET	0
Bit 4	RW	FERFDET	0
Bit 3	RW	BIPWORDO	0
Bit 2		Unused	X
Bit 1	R	LAISV	X
Bit 0	R	FERFV	X

FERFV:

The FERFV bit is set high when line FERF is detected. Line FERF is detected when a 110 binary pattern is detected in bits 6, 7, and 8, of the K2 byte for three or five consecutive frames (as selected by the FERFDET bit in this register). Line FERF is removed when any pattern other than 110 is detected for three or five consecutive frames. This alarm indication is also available on output FERF.

LAISV:

The LAISV bit is set high when line AIS is detected. Line AIS is detected when a 111 binary pattern is detected in bits 6, 7, and 8, of the K2 byte for three or five consecutive frames (as selected by the AISDET bit in this register). Line AIS is removed when any pattern other than 111 is detected for three or five consecutive frames. This alarm indication is also available on output LAIS.

BIPWORDO:

The BIPWORDO bit controls the indication of B2 errors on the B2E output. When BIPWORDO is logic 1, the B2E output is asserted for once per frame whenever one or more B2 bit errors occur during that frame. When BIPWORDO is logic 0, the B2E output is asserted once for every B2 bit error that occurs during that frame (the B2E output can toggle up to 8N times, for N=1,3, or 12). The accumulation of B2 error events functions independently from the B2E output indication, and is controlled by the BIPWORD register bit.

FERFDET:

The FERFDET bit determines the line FERF alarm detection algorithm. When FERFDET is set to logic 1, line FERF is declared when a 110 binary pattern is detected in bits 6,7,8 of the K2 byte for three consecutive frames. When FERFDET is set to logic 0, line FERF is declared when a 110 binary pattern is detected in bits 6,7,8 of the K2 byte for five consecutive frames.

AISDET:

The AISDET bit determines the line AIS alarm detection algorithm. When AISDET is set to logic 1, line AIS is declared when a 111 binary pattern is detected in bits 6,7,8 of the K2 byte for three consecutive frames. When AISDET is set to logic 0, line AIS is declared when a 111 binary pattern is detected in bits 6,7,8 of the K2 byte for five consecutive frames.

ALLONES:

The ALLONES bit controls automatically forcing the ROUT1[7:0], ROUT2[7:0], ROUT3[7:0], ROUT4[7:0] outputs to logical all-ones whenever line AIS is detected. When ALLONES is set to logic 1, the output bus is forced to logic 1 immediately when the line AIS alarm is declared. When line AIS is removed, the outputs are immediately returned to carrying the data sampled on RIN[7:0]. When ALLONES is set to logic 0, the outputs carry the data sampled on RIN[7:0] regardless of the state of the line AIS alarm.

BIPWORD:

The BIPWORD bit controls the accumulation of B2 errors. When BIPWORD is logic 1, the B2 error event counter is incremented only once per frame whenever one or more B2 bit errors occur during that frame. When BIPWORD is logic 0, the B2 error event counter is incremented for each and every B2 bit error that occurs during that frame (the counter can be incremented up to 8xN times per frame, for N=1,3, or 12).

Address 09H**RLOP Interrupt Enable and Status**

Bit	Type	Function	Default
Bit 7	RW	FEBEE	0
Bit 6	RW	BIPEE	0
Bit 5	RW	LAISE	0
Bit 4	RW	FERFE	0
Bit 3	R	FEBEI	X
Bit 2	R	BIPEI	X
Bit 1	R	LAISI	X
Bit 0	R	FERFI	X

FERFI:

The FERFI bit is set high when line FERF is declared or removed. This bit is cleared when the RLOP Interrupt Enable and Status Register is read.

LAISI:

The LAISI bit is set high when line LAIS is declared or removed. This bit is cleared when the RLOP Interrupt Enable and Status Register is read.

BIPEI:

The BIPEI bit is set high when a line BIP error is detected. This bit is cleared when the RLOP Interrupt Enable and Status Register is read.

FERFE:

The FERF interrupt enable is an interrupt mask for line FERF. When FERFE is a logic one, a line interrupt is generated when line FERF is declared or removed.

LAISE:

The LAIS interrupt enable is an interrupt mask for line AIS. When LAISE is a logic one, a line interrupt is generated when line AIS is declared or removed.

BIPEE:

The line BIP error interrupt enable is an interrupt mask for line BIP error events. When BIPEE is a logic one, a line interrupt is generated when a line BIP error (B2) is detected.

FEBEE:

The line far end block error interrupt enable is an interrupt mask for line FEBE events. When FEBEE is a logic one, a line interrupt is generated when a line FEBE indication is detected.

Address 0AH**B2 Error Count #1**

Bit	Type	Function	Default
Bit 7	R	BE[7]	X
Bit 6	R	BE[6]	X
Bit 5	R	BE[5]	X
Bit 4	R	BE[4]	X
Bit 3	R	BE[3]	X
Bit 2	R	BE[2]	X
Bit 1	R	BE[1]	X
Bit 0	R	BE[0]	X

Address 0BH**B2 Error Count #2**

Bit	Type	Function	Default
Bit 7	R	BE[15]	X
Bit 6	R	BE[14]	X
Bit 5	R	BE[13]	X
Bit 4	R	BE[12]	X
Bit 3	R	BE[11]	X
Bit 2	R	BE[10]	X
Bit 1	R	BE[9]	X
Bit 0	R	BE[8]	X

Address 0CH
B2 Error Count #3

Bit	Type	Function	Default
Bit 7		Unused	X
Bit 6		Unused	X
Bit 5		Unused	X
Bit 4		Unused	X
Bit 3	R	BE[19]	X
Bit 2	R	BE[18]	X
Bit 1	R	BE[17]	X
Bit 0	R	BE[16]	X

BE[19:0]:

Bits BE[19] through BE[0] represent the number of line bit-interleaved parity errors that have been detected since the last accumulation interval. The error counters are polled by writing to any of the B2 Error Count Register addresses (0AH, 0BH, or 0CH), or by writing to the Master Reset and Identity Register (03H). Such a write transfers the internally accumulated error count to the registers within 1 μ s and simultaneously resets the internal counters to begin a new cycle of error accumulation. After the 1 μ s period has elapsed, the B2 Error Count Registers may be read.

Address 0DH**FEBE Error Count #1**

Bit	Type	Function	Default
Bit 7	R	FE[7]	X
Bit 6	R	FE[6]	X
Bit 5	R	FE[5]	X
Bit 4	R	FE[4]	X
Bit 3	R	FE[3]	X
Bit 2	R	FE[2]	X
Bit 1	R	FE[1]	X
Bit 0	R	FE[0]	X

Address 0EH**FEBE Error Count #2**

Bit	Type	Function	Default
Bit 7	R	FE[15]	X
Bit 6	R	FE[14]	X
Bit 5	R	FE[13]	X
Bit 4	R	FE[12]	X
Bit 3	R	FE[11]	X
Bit 2	R	FE[10]	X
Bit 1	R	FE[9]	X
Bit 0	R	FE[8]	X

Address 0FH
FEBE Error Count #3

Bit	Type	Function	Default
Bit 7		Unused	X
Bit 6		Unused	X
Bit 5		Unused	X
Bit 4		Unused	X
Bit 3	R	FE[19]	X
Bit 2	R	FE[18]	X
Bit 1	R	FE[17]	X
Bit 0	R	FE[16]	X

FE[19:0]:

Bits FE[19] through FE[0] represent the number of line far end block errors that have been detected since the last accumulation interval. The error counters are polled by writing to any of the FEBE Error Count Register addresses (0DH, 0EH, or 0FH), or by writing to the Master Reset and Identity Register (03H). Such a write transfers the internally accumulated error count to the registers within 1 μ s and simultaneously resets the internal counters to begin a new cycle of error accumulation. After the 1 μ s period has elapsed, the FEBE Error Count Registers may be read.

Address 10H RSOP Control

Bit	Type	Function	Default
Bit 7	R/W	BIPWORD	0
Bit 6	R/W	DDS	0
Bit 5	W	FOOF	X
Bit 4	R/W	ALGO2	0
Bit 3	R/W	BIPEE	0
Bit 2	R/W	LOSE	0
Bit 1	R/W	LOFE	0
Bit 0	R/W	OOFE	0

OOFE:

The OOF interrupt enable is an interrupt mask for out of frame. When OOFE is a logic one, a section interrupt is generated when OOF is declared or removed.

LOFE:

The LOF interrupt enable is an interrupt mask for loss of frame. When LOFE is a logic one, a section interrupt is generated when LOF is declared or removed.

LOSE:

The LOS interrupt enable is an interrupt mask for loss of signal. When LOSE is a logic one, a section interrupt is generated when LOS is declared or removed.

BIPEE:

The section BIP interrupt enable is an interrupt mask for section BIP (B1) error events. When BIPE is a logic one, a section interrupt is generated when a section BIP error is detected.

ALGO2:

The ALGO2 bit position selects the framing algorithm used to determine and maintain the frame alignment. When a logic 1 is written to the ALGO2 bit position, the framer is enabled to use the second of the framing algorithms where only the first A1 framing byte and the first 4 bits of the first A2 framing byte (12 bits total) are examined. This algorithm examines only 12 bits of the framing pattern regardless of the STS mode; all other framing bits are ignored. When a logic 0 is written to the ALGO2 bit position, the framer is enabled to use the first of the framing algorithms where all the A1 framing bytes and all the A2 framing bytes are examined. This algorithm examines all 16 bits of the framing pattern in STS-1 mode, all 48 bits of the framing pattern

in STS-3 mode, all 144 bits of the pattern in STS-9 mode, and all 192 bits in STS-12 mode.

FOOF:

When a logic 1 is written to the force out-of-frame (FOOF) bit location, the STTX is forced out-of-frame at the next frame boundary, regardless of the framing byte values. The out-of-frame event initiates reframing in an upstream framing pattern detector. The FOOF bit is a write only bit; an RSOP Control register read may yield a logic 1 or a logic 0 in this bit position.

DDS:

The disable descrambling (DDS) bit controls the descrambling of the received STS-1/3/12 stream. When a logic one is written to the DDS bit position, the descrambler is disabled. When a logic zero is written to the DDS bit position, the descrambler is enabled.

BIPWORD:

The BIPWORD bit position enables the reporting and accumulating of section BIP word errors. When a logic 1 is written to the BIPWORD bit position, one or more errors in the BIP-8 byte result in a single error indicated per frame on the B1E output and a single error accumulated in the B1 error counter. When a logic 0 is written to the BIPWORD bit position, all errors in the B1 byte are indicated per frame on the B1E output and are accumulated in the B1 error counter.

Address 11H

RSOP Interrupt Status

Bit	Type	Function	Default
Bit 7		Unused	X
Bit 6	R	BIPEI	X
Bit 5	R	LOSI	X
Bit 4	R	LOFI	X
Bit 3	R	OOFI	X
Bit 2	R	LOSV	X
Bit 1	R	LOFV	X
Bit 0	R	OOFV	X

OOFV:

The OOFV bit is set high when out of frame is declared. OOF is declared (OOFV is high) while the STTX is unable to find a valid framing pattern (A1, A2) in the incoming stream. OOF is removed when a valid framing pattern is detected. This alarm indication is also available on output OOF.

LOFV:

The LOFV bit is set high when loss of frame is declared. LOF is declared (LOFV is high) when an out of frame state persists for 3 ms. LOF is removed when an in frame state persists for 3 ms. This alarm indication is also available on output LOF.

LOSV:

The LOSV bit is set high when loss of signal is declared. LOS is declared (LOSV is high) when $20 \pm 2.5 \mu\text{s}$ of consecutive all zeros patterns is detected in the incoming stream.. LOS is removed when two valid framing words (A1, A2) are detected, and during the intervening time (125 μs), no violating period of all zeros patterns is observed. This alarm indication is also available on output LOS.

OOFI:

The OOFI bit is set high when out of frame is declared or removed. This bit is cleared when the RSOP Interrupt Status Register is read.

LOFI:

The LOFI bit is set high when loss of frame is declared or removed. This bit is cleared when the RSOP Interrupt Status Register is read.

LOSI:

The LOSI bit is set high when loss of signal is declared or removed. This bit is cleared when the RSOP Interrupt Status Register is read.

BIPEI:

The BIPEI bit is set high when a section BIP error is detected. This bit is cleared when the RSOP Interrupt Status Register is read.

Address 12H**B1 Error Count #1**

Bit	Type	Function	Default
Bit 7	R	BE[7]	X
Bit 6	R	BE[6]	X
Bit 5	R	BE[5]	X
Bit 4	R	BE[4]	X
Bit 3	R	BE[3]	X
Bit 2	R	BE[2]	X
Bit 1	R	BE[1]	X
Bit 0	R	BE[0]	X

Address 13H**B1 Error Count #2**

Bit	Type	Function	Default
Bit 7	R	BE[15]	X
Bit 6	R	BE[14]	X
Bit 5	R	BE[13]	X
Bit 4	R	BE[12]	X
Bit 3	R	BE[11]	X
Bit 2	R	BE[10]	X
Bit 1	R	BE[9]	X
Bit 0	R	BE[8]	X

BE[15:0]:

Bits BE[15] through BE[0] represent the number of section bit-interleaved parity errors that have been detected since the last accumulation interval. The error counters are polled by writing to any of the B1 Error Count Register addresses (12H, or 13H), or by writing to the Master Reset and Identity Register (03H). Such a write transfers the internally accumulated error count to the registers within 1 μ s and simultaneously resets the internal counters to begin a new cycle of error accumulation. After the 1 μ s period has elapsed, the B1 Error Count Registers may be read.

Address 14H

Serializer Output Port

Bit	Type	Function	Default
Bit 7		Unused	X
Bit 6		Unused	X
Bit 5	RW	SCPO[5]	1
Bit 4	RW	SCPO[4]	1
Bit 3	RW	SCPO[3]	0
Bit 2	RW	SCPO[2]	1
Bit 1	RW	SCPO[1]	0
Bit 0	RW	SCPO[0]	0

SCPO[5:0]:

The values written to the SCPO[5:0] bit in the Serializer output port register directly correspond to the states set on the SCPO[5:0] output pins. This provides a generic port useful for controlling up to 6 signals. The default states for this port are chosen so that SCPO[2:0] controls the MODE[2:0] primary inputs on the serializer devices, SCPO[3] controls the serializer primary input DLCV, and the SCPO[4] and SCPO[5] outputs control the LLEB and the DLEB primary inputs. The outputs controlled by this register are not available with the 180 pin CPGA packaging option.

Address 15H

Serializer Input Port Enable

Bit	Type	Function	Default
Bit 7		Unused	X
Bit 6		Unused	X
Bit 5		Unused	X
Bit 4		Unused	X
Bit 3	RW	SCPIE[3]	0
Bit 2	RW	SCPIE[2]	0
Bit 1	RW	SCPIE[1]	0
Bit 0	RW	SCPIE[0]	0

SCPIE[3:0]:

The SCPIE[3:0] bits are interrupt enables. When a logic one is written to these locations, the occurrence of an event on the corresponding SCPI[3:0] input activates the section layer interrupt. The interrupt is cleared by reading the Serializer Configuration Input Port Status/Value Register. When a logic zero is written to these locations, the occurrence of an event on the corresponding SCPI[3:0] input is inhibited from activating the interrupt.

Address 16H
BIMX Interrupt

Bit	Type	Function	Default
Bit 7		Unused	X
Bit 6		Unused	X
Bit 5		Unused	X
Bit 4		Unused	X
Bit 3		Unused	X
Bit 2		Unused	X
Bit 1	RW	PAEE	0
Bit 0	R	PAEI	X

PAEI:

The PAEI bit is set high when a phase alignment error is detected between the low rate multiplex clock (TICLK), and an internal sampling signal generated by the high rate multiplex clock (TCLK). This bit is cleared when the BIMX Interrupt Register is read.

PAEE:

The PAEE interrupt enable is an interrupt mask for phase alignment error events. When PAEE is a logic one, an interrupt is generated when a phase alignment error is detected.

Address 17H Ring Control

Bit	Type	Function	Default
Bit 7	RW	RINGEN	0
Bit 6	R	INSFERF	X
Bit 5	R	INSAIS	X
Bit 4	RW	AUTOFEBE	0
Bit 3	RW	AUTOFERF	0
Bit 2	RW	AUTORAIS	0
Bit 1	RW	SFERF	0
Bit 0	RW	SAIS	0

SAIS:

The SAIS bit controls the value of the SENDAIS bit position in the receive ring control port stream. The SAIS bit is used to cause a mate STTX to send the line AIS maintenance signal under software control.

SFERF:

The SFERF bit controls the value of the SENDFERF bit position in the receive ring control port stream. The SENDFERF bit value is determined by the logical OR of this register bit, along with the loss of signal, loss of frame, and line AIS alarm states. The SFERF bit is used to cause a mate STTX to send the line FERF maintenance signal under software control.

AUTORAIS:

The AUTORAIS bit enables the automatic insertion of line AIS in the receive direction. When AUTORAIS is a logic one, the detection of receive loss of frame, or receive loss of signal results in the automatic insertion of line AIS in the outgoing receive streams (ROUT1[7:0], ROUT2[7:0], ROUT3[7:0], and ROUT4[7:0]). Note that the insertion of receive line AIS is also controlled by the RLAIS input (when the ring control ports are disabled).

AUTOFERF:

The AUTOFERF bit enables the automatic insertion of line FERF in the transmit direction. When AUTOFERF is a logic one, the detection of loss of frame, loss of signal, or line AIS (when the ring control ports are disabled), or a logic one in the SENDFERF bit position in the transmit ring control port, (when the ring control ports are enabled) results in the automatic insertion of line FERF. Note that the insertion of line FERF is also controlled by the TFERF input (when the ring control ports are disabled) and the FERF bit in the TLOP Control Register.

AUTOFEBE:

The AUTOFEBE bit enables the automatic insertion of line FEBE events in the transmit direction. When AUTOFEBE is a logic one, receive B2 errors detected by the STTX (when the ring control ports are disabled), or from the transmit ring control port, (when the ring control ports are enabled) are automatically inserted in the Z2 byte of the transmit stream. When AUTOFEBE is a logic zero, line FEBE events are not automatically inserted in the transmit stream. Z2 byte inserted upstream of the STTX (using the TDIS input) or inserted from the transmit transport overhead port (using the TTOHEN input) take precedence over the automatic insertion of FEBE events.

INSAIS:

The INSAIS bit allows the value of the SENDAIS bit position in the transmit ring control port to be determined. When the ring control ports are enabled, a logic one in this bit position indicates that the STTX is inserting the line AIS maintenance signal.

INSFERF:

The INSFERF allows the value of the SENDFERF bit position in the transmit ring control port to be determined. When the ring control ports are enabled, a logic one in this bit position indicates that the STTX is inserting the line FERF maintenance signal.

RINGEN:

The RINGEN bit controls the operation of the transmit ring control port when the ring control ports are enabled by the RCP bit in the Master Control/Enable Register. When RINGEN is a logic one, the automatic insertion of line FERF, line AIS, and line FEBE is controlled by bit positions in the transmit ring control port input stream.

When RINGEN is a logic zero, the insertion of line FERF is done automatically based on alarms detected by the receive portion of the STTX (LOF, LOS, and line AIS). Also, line FEBE is inserted based on B2 errors detected by the receive portion of the STTX.

Register 18H

TSOP Control

Bit	Type	Function	Default
Bit 7		Unused	X
Bit 6	R/W	DS	0
Bit 5	R/W	UBT	0
Bit 4	R/W	DC1	0
Bit 3	R/W	DUC	0
Bit 2	R/W	DDL	0
Bit 1	R/W	DOW	0
Bit 0	R/W	LAIS	0

LAIS:

The LAIS bit controls the insertion of line alarm indication signal (AIS). When LAIS is set high, the TSOP inserts line AIS into the TOUT[7:0] stream. Activation or deactivation of line AIS insertion is synchronized to frame boundaries.

DOW:

The DOW bit controls the overwriting of the local orderwire byte (E1). When DOW is logic one, the value sampled on TIN1[7:0] during the E1 byte position is passed through the transmit section overhead processor unaltered, as though the TDIS input had been sampled high during the E1 byte position in the incoming frame. The upstream insertion of the express orderwire is thus accomplished without the use of the TDIS input. Note that only the E1 byte position is passed unaltered, the remaining 2 (STS-3/STM-1) or 11 (STS-12/STM-4) undefined byte positions are overwritten with all zeros. This overwriting may be defeated by using the TDIS input, or by using the UBT bit in this register. When DOW is logic zero, the section order wire source is nominally the TSOW input (while TDIS and TTOHEN are both low).

DDL:

The DDL bit controls the overwriting of the section data communications channel (D1 - D3). When DDL is logic one, the values sampled on TIN1[7:0] during the D1 - D3 byte positions are passed through the transmit section overhead processor unaltered, as though the TDIS input had been sampled high during the D1 - D3 byte positions in the incoming frame. The upstream insertion of the section DCC is thus accomplished without the use of the TDIS input. Note that only the D1 -D3 byte positions are passed unaltered, the remaining 6 (STS-3/STM-1) or 33 (STS-12/STM-4) undefined byte positions are overwritten with all zeros. This overwriting may only be defeated by using the TDIS input, or by using the UBT bit in this register. When DDL is logic zero, the section DCC source is nominally the TSD input (while TDIS and TTOHEN are both low).

DUC:

The DUC bit controls the overwriting of the section user channel byte (F1). When DUC is logic one, the value sampled on TIN1[7:0] during the F1 byte position is passed through the transmit section overhead processor unaltered, as though the TDIS input had been sampled high during the F1 byte position in the incoming frame. The upstream insertion of the user channel is thus accomplished without the use of the TDIS input. Note that only the F1 byte position is passed unaltered, the remaining 2 (STS-3/STM-1) or 11 (STS-12/STM-4) undefined byte positions are overwritten with all zeros. This overwriting may only be defeated by using the TDIS input, or by using the UBT bit in this register. When DUC is logic zero, the section user channel source is nominally the TSUC input (while TDIS and TTOHEN are both low).

DC1:

The DC1 bit controls the overwriting of the identity byte (C1). When DC1 is logic one, the values sampled on TIN1[7:0], TIN2[7:0], TIN3[7:0], and TIN4[7:0] during the C1 byte positions are passed through the transmit section overhead processor unaltered, as though the TDIS input had been sampled high during the C1 byte positions in the incoming frame. The upstream insertion of the user channel is thus accomplished without the use of the TDIS input. Note that all 3 (STS-3/STM-1) or 12 (STS-12/STM-4) identification bytes are passed through unaltered. When DC1 is logic zero, the identity bytes are programmed as specified in the North American references: STS-1 #1 C1 = 01 hexadecimal, STS-1 #2 C1 = 02 hexadecimal, ..., STS-1 #N C1 = N hexadecimal.

UBT:

The UBT bit controls the overwriting of the unused byte positions in the transmit STS-3, or STS-12 stream. The unused bytes are contained in the B1, E1, F1, D1, D2, and D3 byte positions of STS-1 #2 to N (N=3, or 12). When UBT is logic zero, the unused byte positions are overwritten with all zeros. When UBT is logic one, the values sampled on TIN1[7:0], TIN2[7:0], TIN3[7:0], and TIN4[7:0] during the unused byte positions are passed through the transmit section overhead processor unaltered, as though the TDIS input had been sampled high during the unused byte positions in the incoming frame.

DS:

The disable scrambling (DS) bit controls the scrambling of the transmit STS-1/3/12 stream. When a logic one is written to the DS bit position, the scrambler is disabled. When a logic zero is written to the DS bit position, the scrambler is enabled.

Register 19H:
TSOP Diagnostic

Bit	Type	Function	Default
Bit 7		Unused	X
Bit 6		Unused	X
Bit 5		Unused	X
Bit 4		Unused	X
Bit 3		Unused	X
Bit 2	RW	DLOS	0
Bit 1	RW	DBIP8	0
Bit 0	RW	DFP	0

DFP:

The DFP bit controls the insertion of a single bit error continuously in the most significant bit (bit 1) of the A1 section overhead framing byte. If DFP is set high the A1 bytes are set to 76H instead of F6H.

DBIP8:

The DBIP8 bit controls the insertion of bit errors continuously in the B1 section overhead byte. When DBIP8 is set high the B1 byte value is inverted.

DLOS:

The DLOS bit controls the insertion of all zeros in the transmit outgoing stream. When DLOS is set high the output data register is held reset and all output data is forced to 00H.

Register 1AH:
Transmit Z1

Bit	Type	Function	Default
Bit 7	R/W	Z1[7]	0
Bit 6	R/W	Z1[6]	0
Bit 5	R/W	Z1[5]	0
Bit 4	R/W	Z1[4]	0
Bit 3	R/W	Z1[3]	0
Bit 2	R/W	Z1[2]	0
Bit 1	R/W	Z1[1]	0
Bit 0	R/W	Z1[0]	0

Z1[7:0]:

The value written to these bit positions is inserted in the first Z1 byte position of the transmit stream. The Z1 byte is used to carry synchronization status messages between line terminating network elements. Z1[7] is the most significant bit corresponding to bit 1, the first bit transmitted. Z1[0] is the least significant bit, corresponding to bit 8, the last bit transmitted.

Register 1BH:
Receive Z1

Bit	Type	Function	Default
Bit 7	R	Z1[7]	X
Bit 6	R	Z1[6]	X
Bit 5	R	Z1[5]	X
Bit 4	R	Z1[4]	X
Bit 3	R	Z1[3]	X
Bit 2	R	Z1[2]	X
Bit 1	R	Z1[1]	X
Bit 0	R	Z1[0]	X

Z1[7:0]:

The first Z1 byte contained in the receive stream is extracted into this register. The Z1 byte is used to carry synchronization status messages between line terminating network elements. Z1[7] is the most significant bit corresponding to bit 1, the first bit received. Z1[0] is the least significant bit, corresponding to bit 8, the last bit received. An interrupt may be generated when a byte value is received that differs from the value extracted in the previous frame (using the Z1E bit in the Master Control/Enable Register).

Register 1CH
PISO Interrupt

Bit	Type	Function	Default
Bit 7		Unused	X
Bit 6		Unused	X
Bit 5		Unused	X
Bit 4		Unused	X
Bit 3		Unused	X
Bit 2		Unused	X
Bit 1	RW	PAEE	0
Bit 0	R	PAEI	0

PAEI:

The PAEI bit is set high when the transmit STS-1 bit serial interface is enabled and a phase alignment error is detected between the STS-1 byte rate clock (TCLK), and an internal sampling signal generated by the STS-1 bit rate clock (TSICLK). This bit is cleared when the PISO Interrupt Register is read.

PAEE:

When the PAEE is set to logic one, a phase alignment error is enabled to generate an interrupt. When PAEE is logic zero, phase alignment errors are inhibited from generating an interrupt.

Address 1DH
Receive K1

Bit	Type	Function	Default
Bit 7	R	K1[7]	X
Bit 6	R	K1[6]	X
Bit 5	R	K1[5]	X
Bit 4	R	K1[4]	X
Bit 3	R	K1[3]	X
Bit 2	R	K1[2]	X
Bit 1	R	K1[1]	X
Bit 0	R	K1[0]	X

K1[7:0]:

The K1[7:0] bits contain the current K1 code value. The contents of this register are updated when a new K1 code value (different from the current K1 code value) has been received for three consecutive frames. An interrupt may be generated when a new code value is received (using the COAPSE bit in the Master Control/Enable Register). K2[7] is the most significant bit corresponding to bit 1, the first bit received. K2[0] is the least significant bit, corresponding to bit 8, the last bit received.

Address 1EH
Receive K2

Bit	Type	Function	Default
Bit 7	R	K2[7]	X
Bit 6	R	K2[6]	X
Bit 5	R	K2[5]	X
Bit 4	R	K2[4]	X
Bit 3	R	K2[3]	X
Bit 2	R	K2[2]	X
Bit 1	R	K2[1]	X
Bit 0	R	K2[0]	X

K2[7:0]:

The K2[7:0] bits contain the current K2 code value. The contents of this register are updated when a new K2 code value (different from the current K2 code value) has been received for three consecutive frames. An interrupt may be generated when a new code value is received (using the COAPSE bit in the Master Control/Enable Register). K2[7] is the most significant bit corresponding to bit 1, the first bit received. K2[0] is the least significant bit, corresponding to bit 8, the last bit received.

Address 1FH**Serializer Configuration Input Port Status/Value**

Bit	Type	Function	Default
Bit 7		Unused	X
Bit 6		Unused	X
Bit 5	R	SCPIV[1]	X
Bit 4	R	SCPIV[0]	X
Bit 3	R	SCPII[3]	X
Bit 2	R	SCPII[2]	X
Bit 1	R	SCPII[1]	X
Bit 0	R	SCPII[0]	X

SCPII[3:0]:

The SCPII[3:0] bits are interrupt indications. A logic one in any bit location indicates that an event has occurred on the corresponding SCPI[3:0] input. More specifically, a logic one in either of the SCPII[3:2] bit locations indicates that the signal on the corresponding SCPI[3:2] input has transitioned from logic zero to logic one (i.e. upon detection of a rising edge); a logic one in any of the SCPII[1:0] bit locations indicates that the signal on the corresponding SCPI[1:0] input has transitioned either from logic zero to logic one or from logic one to logic zero (i.e. upon a change of state). The SCPII[3:0] bits are cleared by reading this register. These register bits function independently from the Serializer Configuration input Port Enable register bits; the SCPII[3:0] bits will indicate events occurring on the SCPI[3:0] inputs regardless of whether or not these events are enabled to generate an interrupt. It is intended that the SCPI[1:0] inputs monitor the state of the clock recovery PLL out-of-lock signal and the clock synthesis out-of-lock signal. SCPI[3:2] monitors the state of the serializer LCV signal and the serializer PAE signal. SCPI[3:0] are not available with the 180 pin CPGA packaging option.

SCPIV[1:0]:

The SCPIV[1:0] bits are real-time input port state indications. A logic one in any bit location indicates that the signal on the corresponding SCPI[1:0] input is a logic one. A logic zero in any bit location indicates that the signal on the corresponding SCPI[1:0] input is a logic zero. The state of the SCPI[1:0] inputs are latched and held during a microprocessor read of this register. SCPI[3:0] are not available with the 180 pin CPGA packaging option.

TEST FEATURES DESCRIPTION

Simultaneously asserting the CSB, RDB, and WRB inputs causes all output pins, and the data bus to be held in a high-impedance state. This test feature may be used for board or module level testing.

Test mode registers are used to apply test vectors during production testing of the STTX. Test mode registers (as opposed to normal mode registers) are selected when A5 is high (SLIM=0) or when A4 is high (SLIM=1).

Test mode registers may also be used for board or module level testing. When all of the constituent TSBs within the STTX are placed in test mode 0, device inputs may be observed, and device outputs may be controlled via the microprocessor interface (refer to the "Test Mode 0" section below for details).

Test Mode Register Memory Map

SLIM=0	SLIM=1			Register
	A[5:0]	SCSB	LCSB	
00H-0FH	1	0	00-0FH	Reserved for normal registers
10H-1FH	0	1	00-0FH	Reserved for normal registers
20H	1	0	10H	Serializer Test Register 0
21H	1	0	11H	Serializer Test Register 1
22H	1	0	12H	Serializer Test Register 2
23H	1	0	13H	Master Test
24H	1	0	14H	TLOP Test Register 0
25H	1	0	15H	TLOP Test Register 1
26H	1	0	16H	TLOP Test Register 2
27H	1	0	17H	TLOP Test Register 3
28H	1	0	18H	RLOP Test Register 0
29H	1	0	19H	RLOP Test Register 1
2AH	1	0	1AH	RLOP Test Register 2
2BH	1	0	1BH	RLOP Test Register 3
2CH	1	0	1CH	RLOP Test Register 4
2DH-2FH	1	0	1D-1FH	Reserved
30H	0	1	10H	RSOP Test Register 0
31H	0	1	11H	RSOP Test Register 1
32H	0	1	12H	RSOP Test Register 2
33H	0	1	13H	RSOP Test Register 3
34H	0	1	14H	BIDX Test Register 0
35H	0	1	15H	BIDX Test Register 1
36H	0	1	16H	BIMX Test Register 0
37H	0	1	17H	BIMX Test Register 1
38H	0	1	18H	TSOP Test Register 0
39H	0	1	19H	TSOP Test Register 1
3AH	0	1	1AH	TSOP Test Register 2
3BH	0	1	1BH	TSOP Test Register 3

3CH	0	1	1CH	PISO Test Register 0
3DH	0	1	1DH	PISO Test Register 1
3EH	0	1	1EH	PISO Test Register 2
3FH	0	1	1FH	Reserved

Notes on Register Bits:

1. Writing values into unused register bits has no effect. Reading back unused bits can produce either a logic one or a logic zero; hence unused bits should be masked off by software when read.
2. Writeable register bits are not initialized upon reset unless otherwise noted.

Address 23H

Master Test

Bit	Type	Function	Default
Bit 7		Unused	X
Bit 6		Unused	X
Bit 5		Unused	X
Bit 4	W	PMCTST	X
Bit 3	W	DBCTRL	X
Bit 2	R/W	IOTST	0
Bit 1	W	HIZDATA	X
Bit 0	R/W	HIZIO	0

This register is used to enable STTX test features. All bits, except PMCTST, are reset to zero by a reset of the STTX.

HIZIO,HIZDATA:

The HIZIO and HIZDATA bits control the tri-state modes of the STTX. While the HIZIO bit is a logic one, all output pins of the STTX except the data bus are held in a high-impedance state. The microprocessor interface is still active. While the HIZDATA bit is a logic one, the data bus is also held in a high-impedance state which inhibits microprocessor read cycles.

IOTST:

The IOTST bit is used to allow normal microprocessor access to the test registers and control the test mode in each TSB block in the STTX for board level testing. When IOTST is a logic one, all blocks are held in test mode and the microprocessor may write to a block's test mode 0 registers to manipulate the outputs of the block and consequently the device outputs (refer to the "Test Mode 0 Details" in the "Test Features" section).

DBCTRL:

The DBCTRL bit is used to pass control of the data bus drivers to the CSB pin. When the DBCTRL bit is set to logic one, the CSB pin controls the output enable for the data bus. While the DBCTRL bit is set, holding the CSB pin high causes the STTX to drive the data bus and holding the CSB pin low tri-states the data bus. The DBCTRL bit overrides the HIZDATA bit. The DBCTRL bit is used to measure the drive capability of the data bus driver pads.

PMCTST:

The PMCTST bit is used to configure the STTX for PMC's manufacturing tests. When PMCTST is set to logic one, the STTX microprocessor port becomes the test access port used to run the PMC "canned" manufacturing test vectors. The PMCTST bit is logically "ORed" with the IOTST bit, and can only be cleared by setting CSB to logic one.

Test Mode 0

In test mode 0, the STTX allows the logic levels on most device inputs to be observed through the microprocessor interface, and allows the device outputs to be controlled to either logic level through the microprocessor interface.

Test mode 0 is enabled by resetting the device (using the RSTB input, or the Master Reset and Identity register), and then setting the IOTST bit in the Master Test register. The following addresses must then be written with the value 00H: 21H, 25H, 29H, 31H, 35H, 37H, 39H, 3DH. The Master Configuration register (address 00H) is written with the value 23H. Applying a rising edge (logic zero to logic one transition) on the RICLK and TCLK inputs followed by a read from the following locations returns the value for the indicated pins:

Addr	Bit 7	Bit 6	Bit 5	Bit 4	Bit 3	Bit 2	Bit 1	Bit 0
1AH				TTOH[4]	TTOH[3]	TTOH[2]	TTOH[1]	TTOHEN
20H							RSICLK	RSIN
24H		TLOW	TLD	TFERF	TAPS			
30H						RLAIS	RIFP	
32H	RIN[7]	RIN[6]	RIN[5]	RIN[4]	RIN[3]	RIN[2]	RIN[1]	RIN[0]
36H						TIFP	TDIS	TICLK
36H*	TIN1[7]	TIN1[6]	TIN1[5]	TIN1[4]	TIN1[3]	TIN1[2]	TIN1[1]	TIN1[0]
36H**	TIN2[7]	TIN2[6]	TIN2[5]	TIN2[4]	TIN2[3]	TIN2[2]	TIN2[1]	TIN2[0]
36H***	TIN3[7]	TIN3[6]	TIN3[5]	TIN3[4]	TIN3[3]	TIN3[2]	TIN3[1]	TIN3[0]
36H****	TIN4[7]	TIN4[6]	TIN4[5]	TIN4[4]	TIN4[3]	TIN4[2]	TIN4[1]	TIN4[0]
38H	TSUC	TSOW	TSD			TLAIS		
3CH							TSICLK	

Notes: *The address 36 must be written with the value 01H prior to reading these device inputs.

**The address 36 must be written with the value 02H prior to reading these device inputs.

***The address 36 must be written with the value 03H prior to reading these device inputs.

****The address 36 must be written with the value 04H prior to reading these device inputs.

A write to one of the following locations followed a falling edge (logic one to logic zero transition) on the RICLK and TCLK inputs forces each output to the value in the corresponding bit position:

Addr	Bit 7	Bit 6	Bit 5	Bit 4	Bit 3	Bit 2	Bit 1	Bit 0
24H			TAPCLK	TOWCLK	TLDCLK			
28H	RAPS	B2E	B2E	FERF	LAIS			
2AH		RAPCLK	RLD	RLDCLK	RLOW	ROWCLK		
2BH			RTOHFP	RTOHCLK	RTOH[4]	RTOH[3]	RTOH[2]	RTOH[1]
30H	B1E	B1E	LOF	OOF	LOS			
32H			RSOW		RSD	RSDCLK	RSUC	
34H	ROUT1[7]	ROUT1[6]	ROUT1[5]	ROUT1[4]	ROUT1[3]	ROUT1[2]	ROUT1[1]	ROUT1[0]
34H*	ROUT2[7]	ROUT2[6]	ROUT2[5]	ROUT2[4]	ROUT2[3]	ROUT2[2]	ROUT2[1]	ROUT2[0]
34H**	ROUT3[7]	ROUT3[6]	ROUT3[5]	ROUT3[4]	ROUT3[3]	ROUT3[2]	ROUT3[1]	ROUT3[0]
34H***	ROUT4[7]	ROUT4[6]	ROUT4[5]	ROUT4[4]	ROUT4[3]	ROUT4[2]	ROUT4[1]	ROUT4[0]
35H			ROCLK	ROFP				
36H			TTOHCLK	TTOHFP		GTICK		
38H					TSDCLK			
3AH	TOUT[7]	TOUT[6]	TOUT[5]	TOUT[4]	TOUT[3]	TOUT[2]	TOUT[1]	TOUT[0]/ TOFP
3CH							TSOUT	

Notes: *The address 34 must be written with the value 01H prior to writing these device outputs.

**The address 34 must be written with the value 02H prior to writing these device outputs.

***The address 34 must be written with the value 03H prior to writing these device outputs.

FUNCTIONAL TIMING

Fig. 1 STS-3 Transmit Frame Pulse and Data Alignment

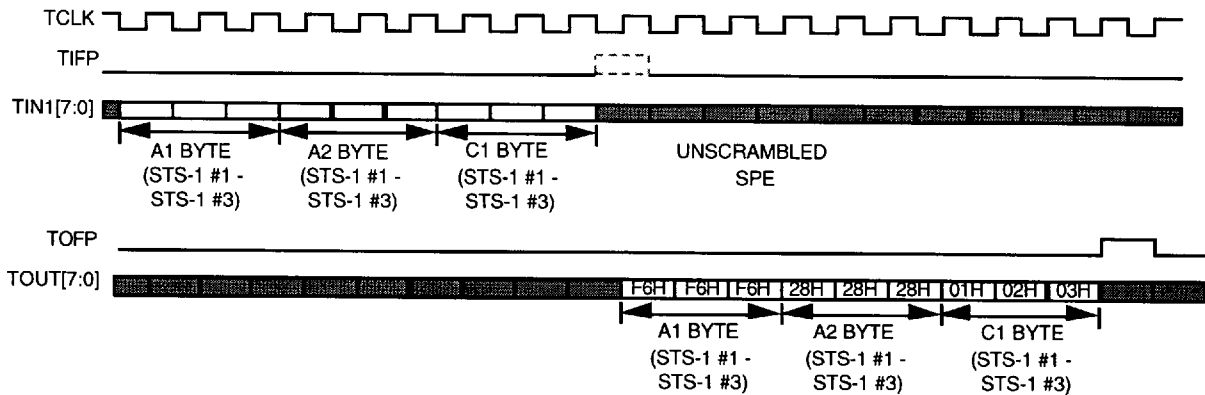

The STS-3 transmit frame pulse and data alignment timing diagram (figure 1) illustrates the transmit frame pulse input/output alignment for an STS-3 (STM-1) frame when the byte interleaved multiplexer is bypassed. The input frame pulse is aligned to the byte immediately following the third C1 byte, and it is not always necessary for this pulse to be present.

Fig. 2 STS-1 Bit Serial Transmit Frame Pulse and Data Alignment

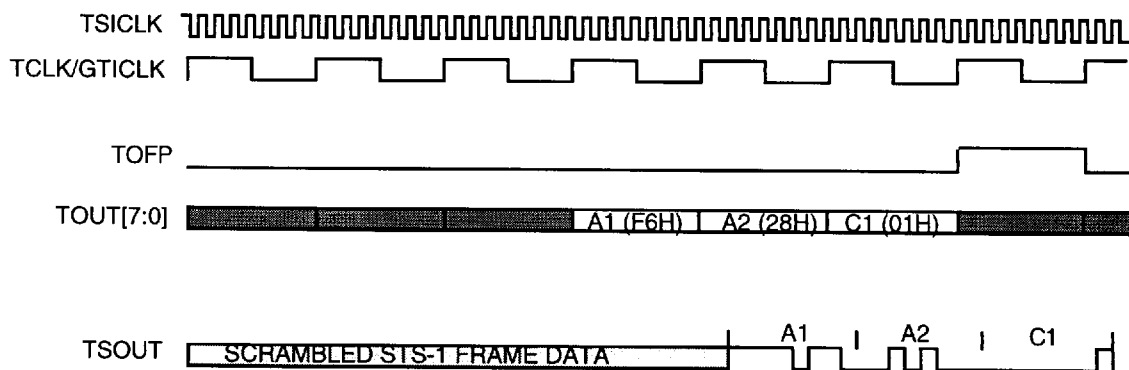

The STS-1 bit serial transmit frame pulse and data alignment timing diagram (figure 2) illustrates STS-1 bit serial operation for a contra-directional timing based application. The STS-1 transmit clock, TSICLK, is divided by eight to produce the byte serial transmit clock, GTICLK. In this application, GTICLK is connected directly to TCLK, and bytes are "pulled" from an upstream path overhead insertion/payload mapping device.

Fig. 3 STS-1 Byte Serial Transmit Frame Pulse and Data Alignment

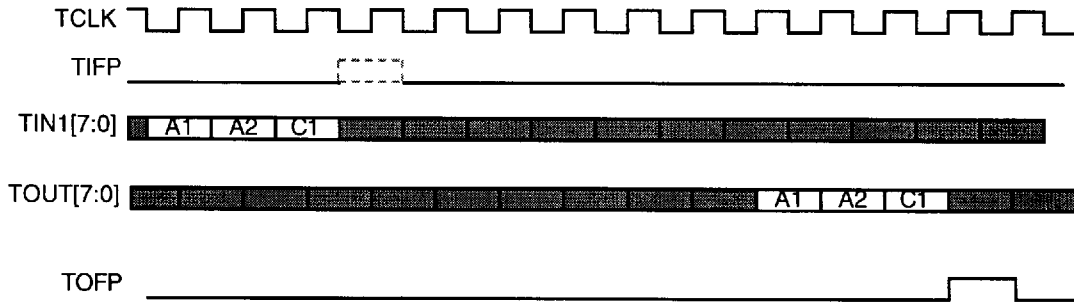

The STS-1 byte serial transmit frame pulse and data alignment timing diagram (figure 3) illustrates the transmit frame pulse input/output alignment for an STS-1 frame. The input frame pulse is aligned to the byte immediately following the C1 byte, and it is not always necessary for this pulse to be present.

Fig. 4 Byte Interleaved Multiplex Frame Pulse and Data Alignment

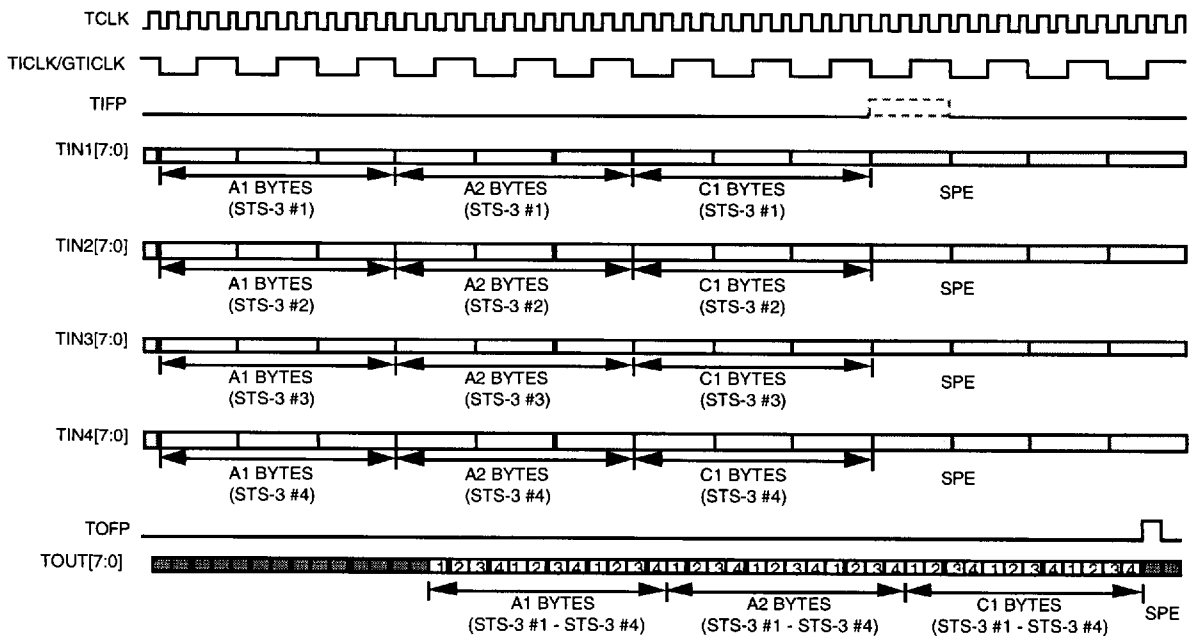

The byte interleaved multiplex frame pulse and data alignment timing diagram (figure 4) illustrates the transmit frame pulse and data alignment for four incoming STS-3 (STM-1) frames multiplexed into an outgoing STS-12 (STM-4) frame. The diagram illustrates a contra directional timing based application. The STS-12 transmit clock, TCLK, is divided by four to produce the STS-3 byte serial transmit clock, GTICLK. In this application, GTICLK is connected directly to TICLK, and bytes are "pulled" from upstream path overhead insertion/payload mapping devices.

Similar to the diagram above for the STS-1 to STS-3 multiplexing mode, the frame pulse output, TOFP, is aligned to the byte immediately following the last C1 in the outgoing frame. The input frame pulse is aligned to the byte immediately following the last C1 byte in all multiplexing modes and it is not always necessary for this pulse to be present.

Fig. 5 STS-3 Receive Frame Pulse and Data Alignment

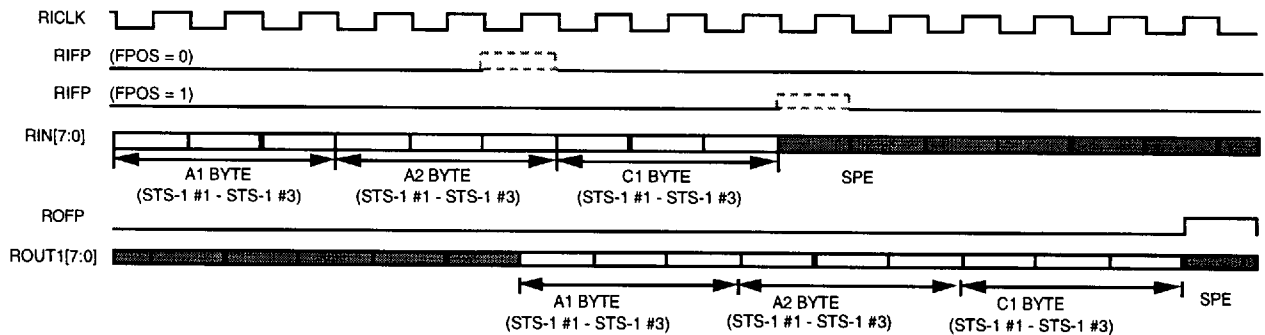

The STS-3 Receive Frame Pulse and Data Alignment timing diagram (figure 5) illustrates the receive frame pulse input/output alignment for an STS-3 (STM-1) frame when the byte interleaved demultiplexer is bypassed. The STTX requires an external serial to parallel converter to produce the byte serial input stream, RIN[7:0]. The ROFP output is set high during the first SPE byte of the first row of the SONET frame (immediately following the C1 byte), and may be used by downstream circuitry for frame alignment. While the STTX is out-of-frame, ROFP is updated based on the last frame alignment.

Fig. 6 STS-1 Bit Serial Receive Frame Pulse and Data Alignment

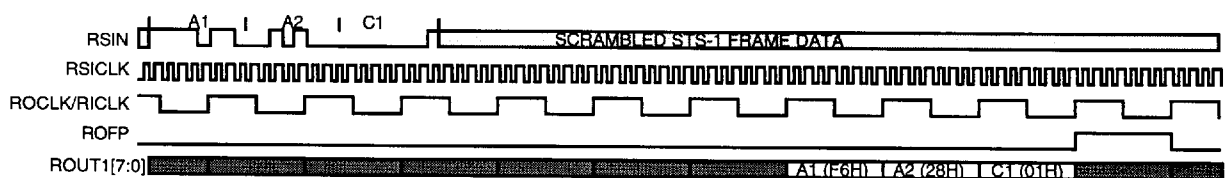

The STS-1 Bit Serial Receive Frame Pulse and Data Alignment timing diagram (figure 6) illustrates the receive frame alignment for an STS-1 frame. The STTX converts the bit serial STS-1 stream, RSIN, to byte serial format. Output ROCLK is a divide by eight of the bit serial line clock, RSICLK, and must be externally connected to RICK for proper operation. The ROFP output is set high during the first SPE byte of the first row of the SONET frame (immediately following the C1 byte), and may be used by downstream circuitry for frame alignment. While the STTX is out-of-frame, ROFP is updated based on the last frame alignment.

Fig. 7 STS-1 Byte Serial Receive Frame Pulse and Data Alignment

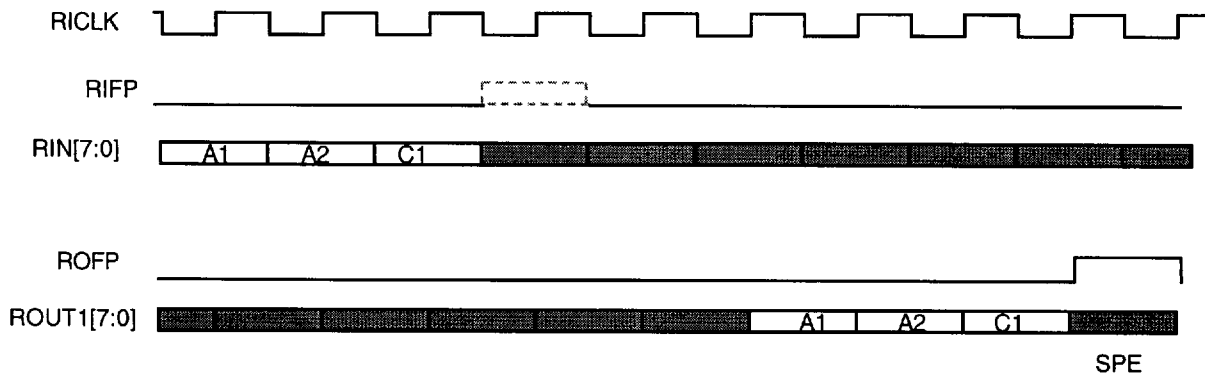

The STS-1 Byte Serial Receive Frame Pulse and Data Alignment timing diagram (figure 7) illustrates the receive frame alignment for an STS-1 frame. The ROFP output is set high during the first SPE byte of the first row of the SONET frame (immediately following the C1 byte), and may be used by downstream circuitry for frame alignment. While the STTX is out-of-frame, ROFP is updated based on the last frame alignment.

Fig. 8 Byte Interleaved Demultiplex Frame Pulse and Data Alignment

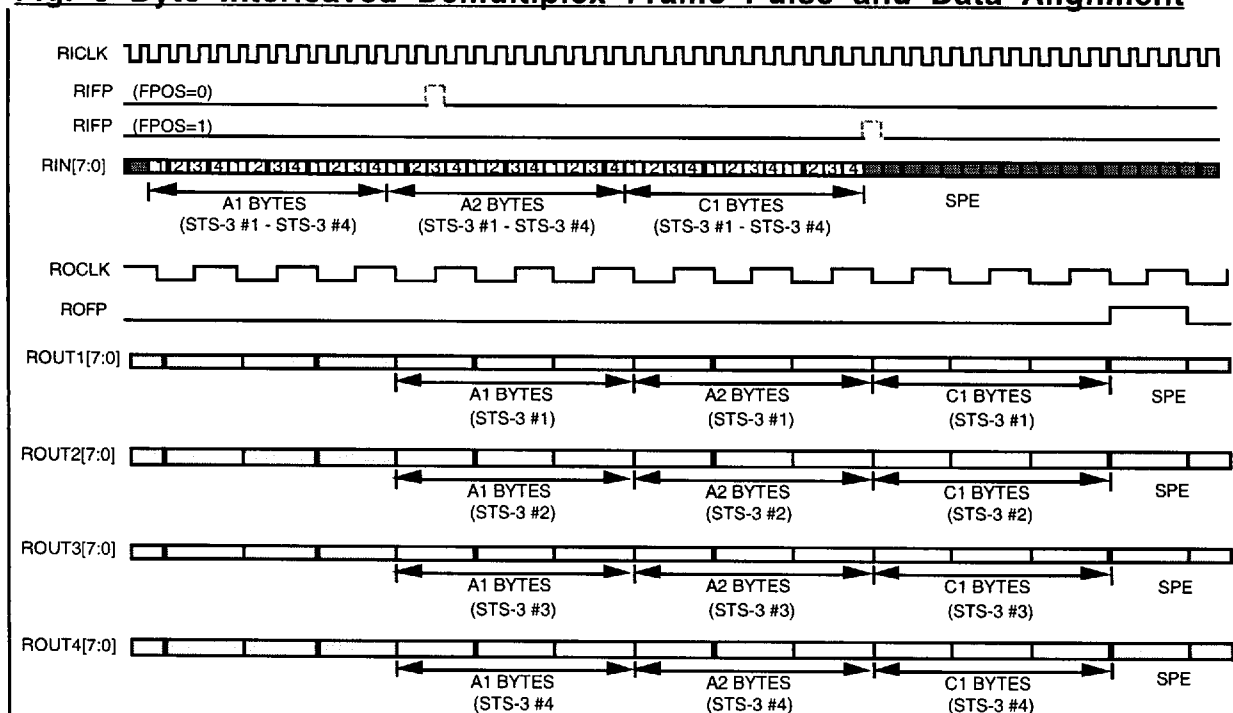

The byte interleaved demultiplex frame pulse and data alignment timing diagram (figure 8) illustrates the receive frame pulse and data alignment within a single incoming STS-12 (STM-4) frame and four outgoing STS-3 (STM-1) frames. The STTX requires an external serial to parallel converter to produce the byte serial

input stream, RIN[7:0]. The frame pulse output, ROFP, is aligned to the byte immediately following the third C1 byte in the STS-3 streams.

Similar to the diagram above for the STS-3 to STS-1 demultiplexing mode, the frame pulse output, ROFP, is aligned to the byte immediately following the last C1 byte in the outgoing frame.

Fig. 9 Transport Overhead Overwrite Enable and Disable with Multiplexing Bypassed

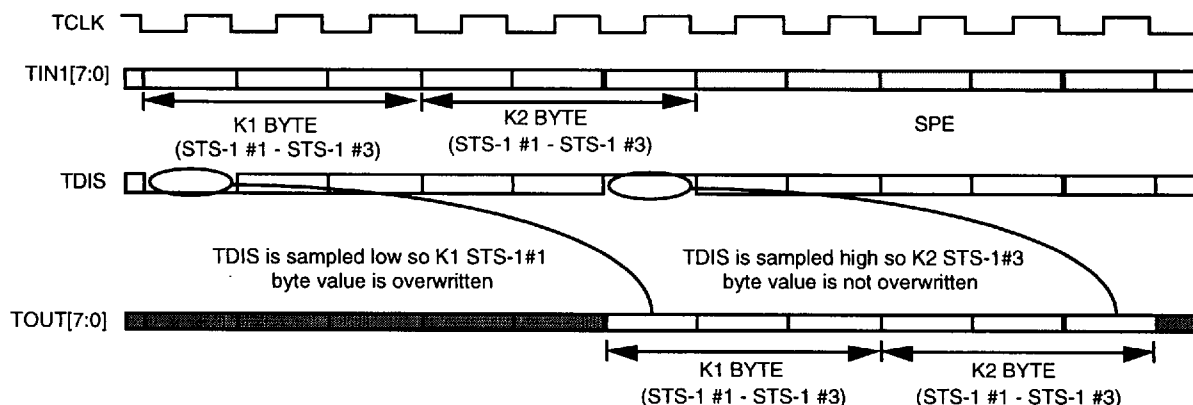

The transport overhead overwrite enable and disable timing diagram (figure 9) illustrates the operation of the TOH overwrite disable feature, while the byte interleaved multiplexer is bypassed. It is assumed that the TTOHEN input is low. The diagram shows input TDIS sampled low during the K1 STS-1 #1 byte and then sampled high during the K2 STS-1 #3 byte. Since TDIS was low the byte value in the K1 STS-1 #1 byte position for the output data TOUT[7:0] is overwritten with the value shifted in on TAPS (or the value contained in the Transmit K1/K2 Registers depending on the level of the APSREG bit in the Master Control/Enable Register). However, the byte value in the K2 STS-1 #3 position for the output data TOUT[7:0] is not overwritten with an all zero byte because TDIS was sampled high during this byte position on the input data stream.

An error insertion feature is also provided for the B1 and B2 byte positions. When TDIS is held high during any or all of the B1 or B2 byte positions, the associated data sampled on TIN1[7:0] is used as an error insertion mask. A logic one in a given bit position causes the inversion of the corresponding B1 or B2 bit position prior to transmission. A logic zero in a given bit position causes the corresponding B1 or B2 bit position to be transmitted uncorrupted.

Fig. 10 Transport Overhead Overwrite Enable and Disable with Multiplexing Enabled

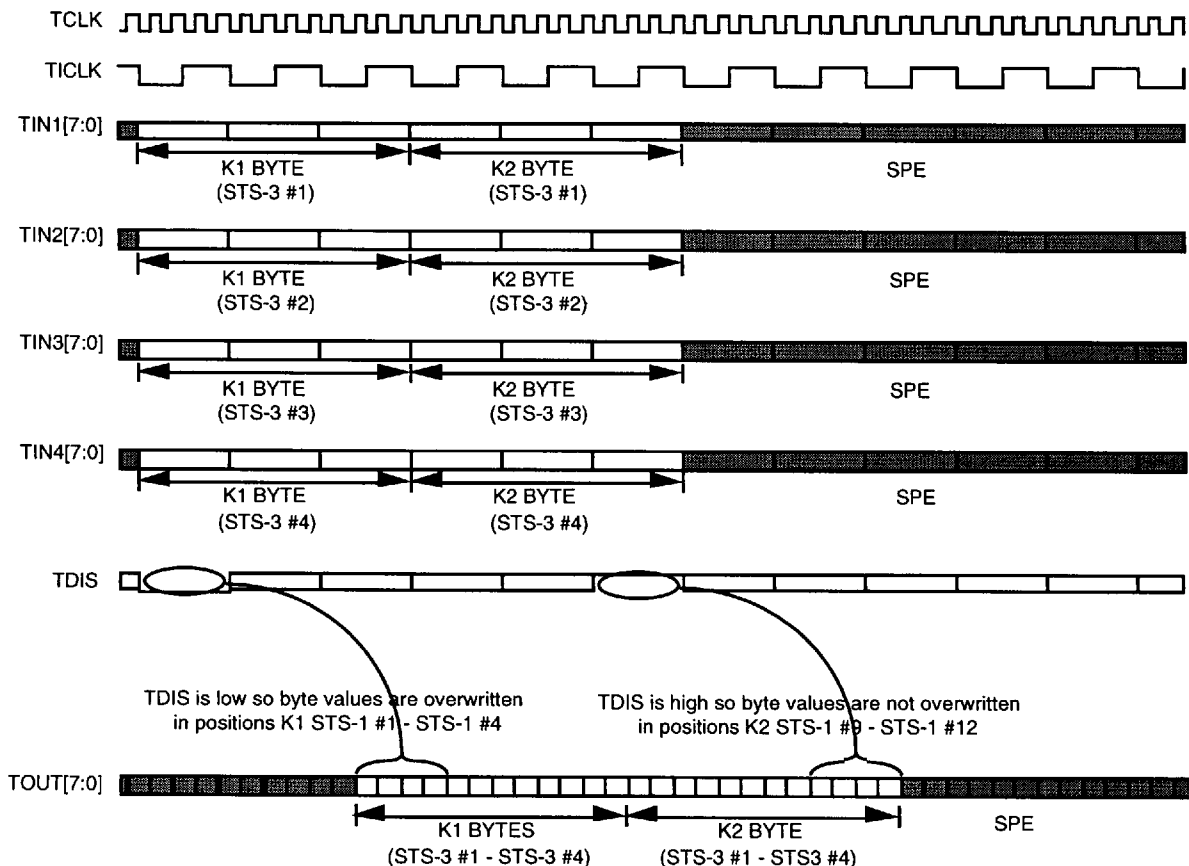

The transport overhead overwrite enable and disable timing diagram (figure 10) illustrates the operation of the TOH overwrite disable feature, while the byte interleaved multiplexer is enabled. The diagram shows input TDIS sampled low during the first K1 bytes of STS-3 #1 - #4 and then sampled high during the third K2 bytes of STS-3 #1 - #4 bytes. Since TDIS was low the byte values in the first K1 byte of STS-3 #1 is overwritten with the value shifted in on TAPS (or the value contained in the Transmit K1/K2 Registers depending on the level of the APSREG bit in the Master Control/Enable Register). The K1 byte positions of STS-3 #2, #3, and #4 are overwritten with all zeros. However, the byte values in the third K2 byte positions of STS-3 #1- #4 are not overwritten because TDIS was sampled high during these byte positions in the input data streams.

An error insertion feature is also provided for the B1 and B2 byte positions. When TDIS is held high during any or all of the B1 or B2 byte positions, the associated data sampled on the low speed inputs is used as an error insertion mask. A logic one in a given bit position causes the inversion of the corresponding B1 or B2 bit position prior to transmission. A logic zero in a given bit position causes the corresponding B1 or B2 bit position to be transmitted uncorrupted.

Fig. 11 In Frame Declaration

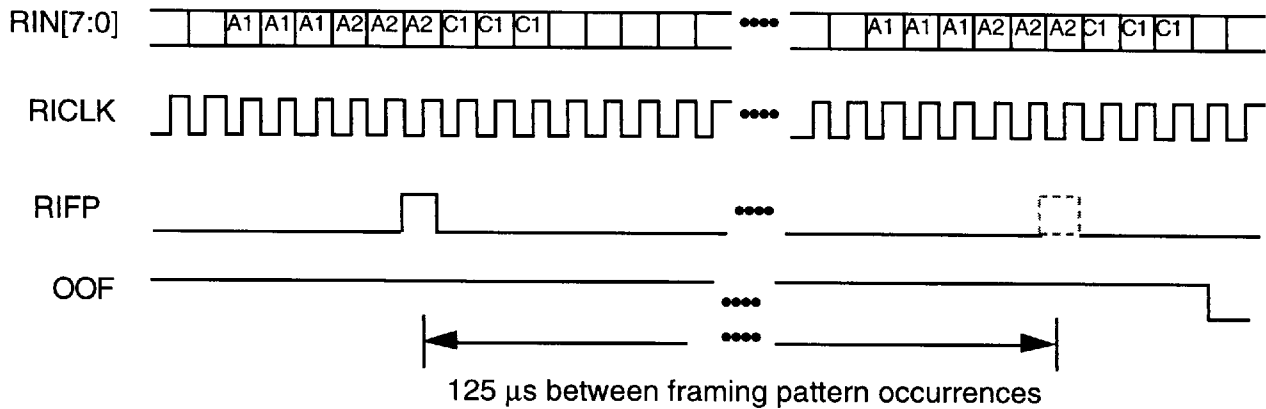

The in frame declaration timing diagram (figure 11) illustrates the declaration of in-frame by the STTX when processing an STS-3 (STM-1) stream on RIN[7:0]. An upstream serial to parallel converter device produces a frame aligned, byte serial stream. The frame verification is initialized by a pulse on RIFP while the STTX is out of frame. In frame is declared if the framing pattern is observed in the correct byte positions in the following frame, and in the intervening period (125 μs) no additional pulses were present on FPIN. The STTX ignores pulses on RIFP while in frame. This algorithm results in a maximum average reframe time of 250 μs in the absence of mimic framing patterns.

Fig. 12 Out of Frame Declaration

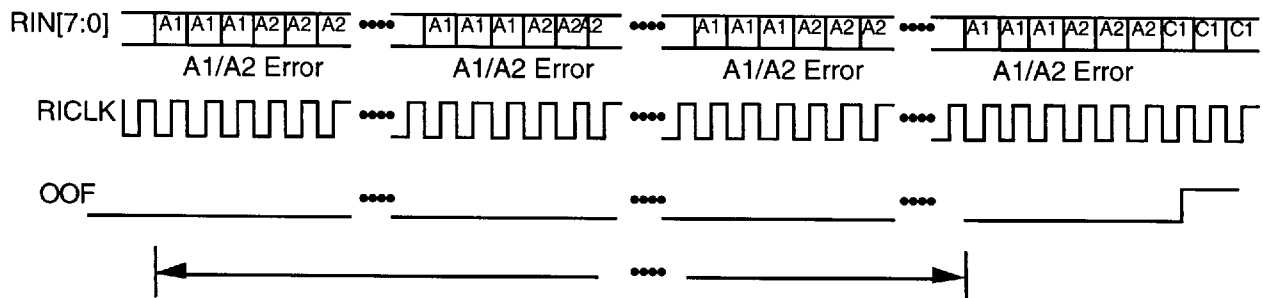

Four consecutive frames containing framing pattern errors

The out of frame declaration timing diagram (figure 12) illustrates the declaration of out of frame. In an STS-3 (STM-1) stream, the framing pattern is a 48 bit pattern that repeats once per frame. In an STS-12 stream, the framing pattern is a 196 bit pattern that repeats once per frame (for the purposes of OOF declaration, the framing pattern may be modified using the ALGO2 bit in the RSOP Control Register). Out of frame is declared when one or more errors are detected in this pattern for four consecutive frames as illustrated. In the presence of random data, out of frame will normally be declared within 500 μs.

Fig. 13 Loss of Signal Declaration/Removal

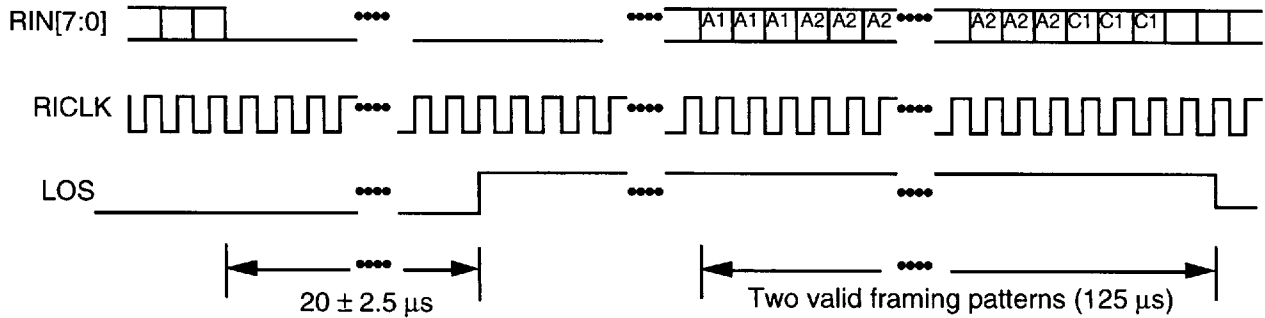

The loss of signal declaration/removal timing diagram (figure 13) illustrates the operation of the LOS output. LOS is declared when a violating period of all zeros ($20 \pm 2.5 \mu s$) is observed on RIN[7:0] (note the same criteria applies to RSIN when processing an STS-1 stream). LOS is removed when two valid framing patterns are observed, and in the intervening period ($125 \mu s$), no violating periods of all zeros is observed.

Fig. 14 Loss of Frame Declaration/Removal

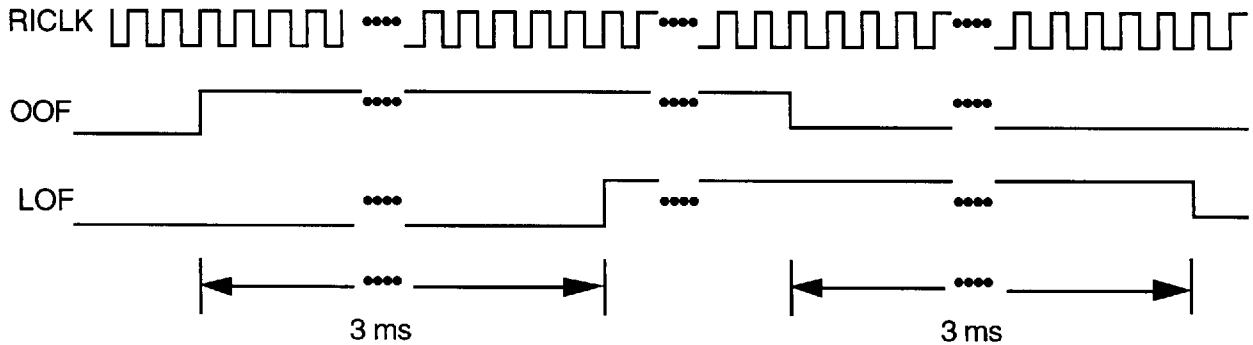

The loss of frame declaration/removal timing diagram (figure 14) illustrates the operation of the LOF output. LOF is an integrated version of OOF. LOF is declared when an out of frame condition persists for 3 ms. LOF is removed when an in frame condition persists for 3 ms.

Fig. 15 Line AIS and Line FERF Declaration/Removal

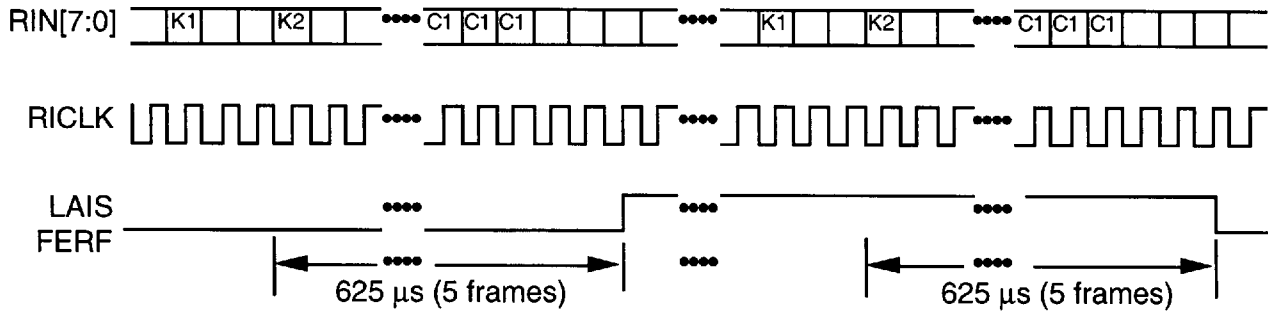

The line AIS and line FERF declaration/removal timing diagram (figure 15) illustrates the operation of the LAIS and FERF outputs. An STS-3 (STM-1) stream is shown for illustrative purposes. LAIS (FERF) is declared when the binary pattern '111' ('110') is observed in bits 6,7, and 8 of the K2 byte for five consecutive frames (the declaration/removal threshold may be changed to three consecutive frames under software control). LAIS (LFERF) is removed when any pattern other than the binary pattern '111' ('110') is observed in bits 6,7, and 8 of the K2 byte for five consecutive frames. LAIS and FERF may be declared or removed once per frame.

Fig. 16 Transmit Overhead Clock and Data Alignment

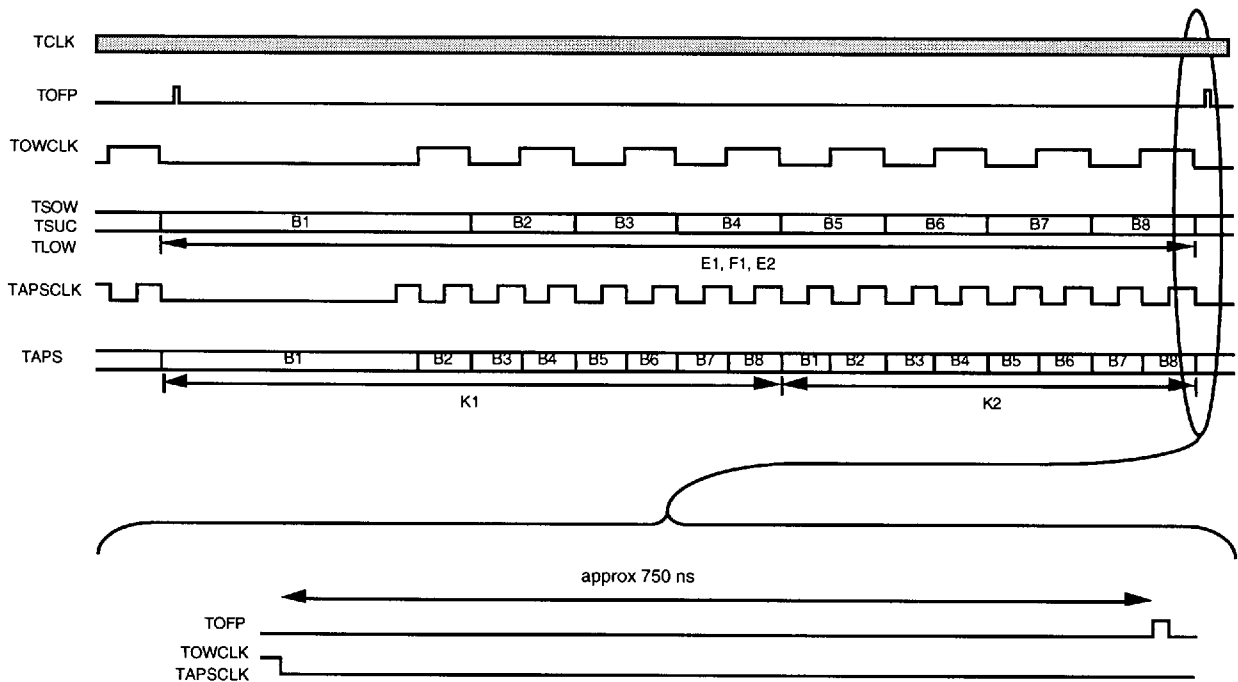

The transmit overhead clock and data alignment timing diagram (figure 16) shows the relationship between the TSOW, TLOW, TSUC and TAPS serial data inputs and their associated clocks, TOWCLK and TAPSCCLK. TOWCLK is a 72 kHz 50% duty cycle clock that is gapped to produce a 64 kHz nominal rate and is aligned as shown in the timing diagram. TAPSCCLK is a 144 kHz 50% duty cycle clock that is gapped to produce a 128 kHz nominal rate and is aligned as shown in the timing diagram. The E1, E2, F1, K1 and K2 bytes shifted into the STTX on TSOW, TLOW, TSUC, and TAPS in the frame shown are inserted in the corresponding transport overhead channels in the next frame.

Fig. 17 Receive Overhead Clock and Data Alignment

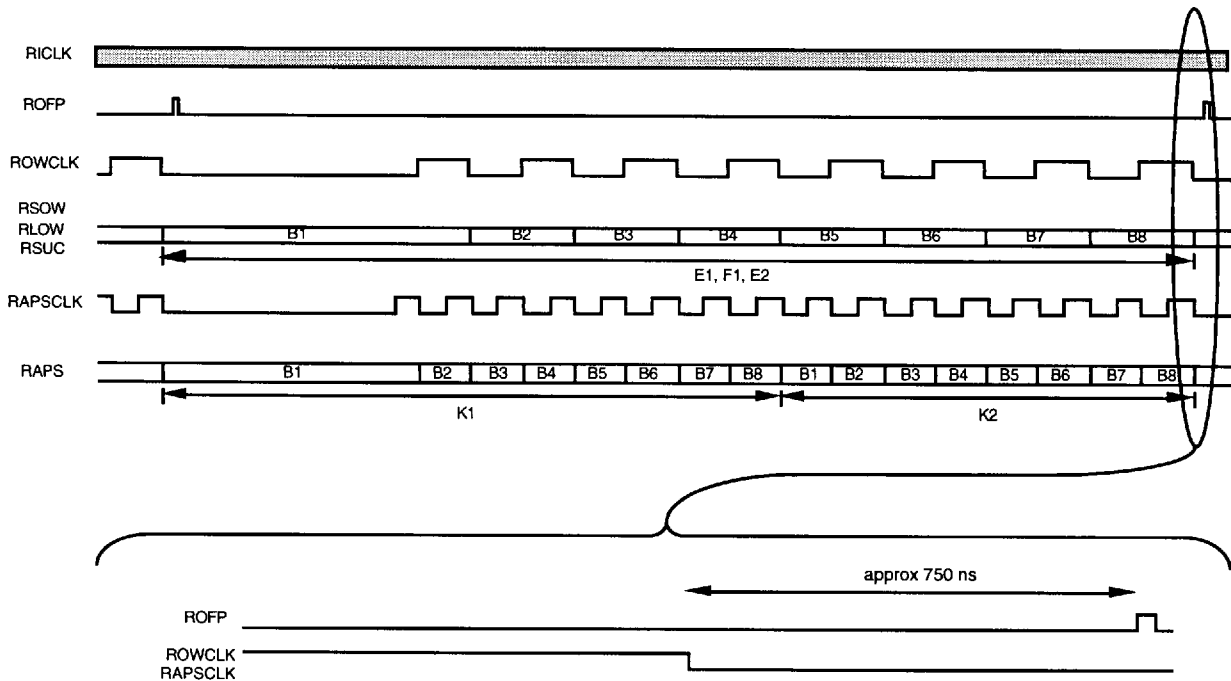

The receive overhead alignment timing diagram (figure 17) shows the relationship between the RSOW, RSUC, RLOW, and RAPS serial data outputs and their associated clocks, ROWCLK and RAPSCLK. ROWCLK is a 72 kHz 50% duty cycle clock that is gapped to produce a 64 kHz nominal rate and is aligned as shown in the timing diagram. RAPSCLK is a 144 kHz 50% duty cycle clock that is gapped to produce a 128 kHz nominal rate and is aligned as shown in the timing diagram. The E1, F1, E2, K1 and K2 bytes shifted out of the STTX on RSOW, RSUC, RLOW, and RAPS in the frame shown are extracted from the corresponding transport overhead channels in the previous frame.

Fig. 18 Transmit Data Link Clock and Data Alignment

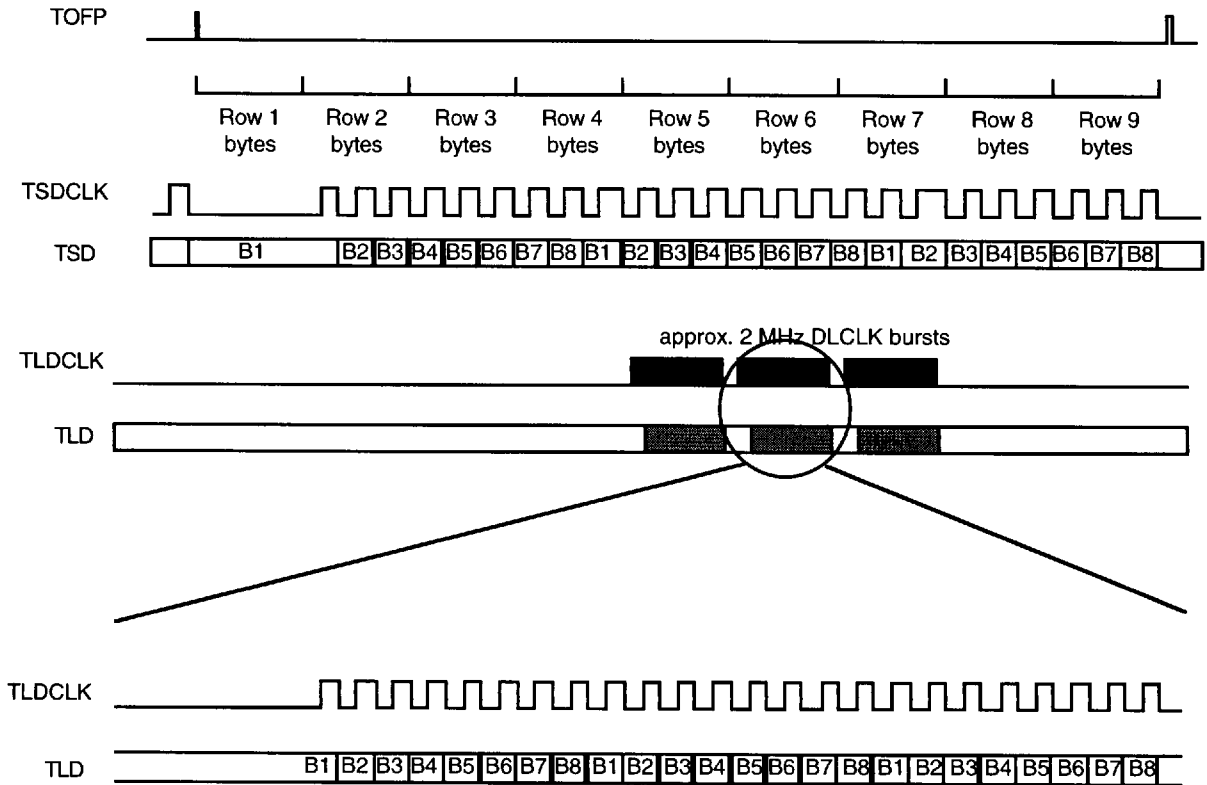

The transmit data link clock and data alignment timing diagram (figure 18) shows the relationship between the TSD, and TLD serial data inputs, and their associated clocks, TSDCLK and TLDCLK respectively. TSDCLK is a 216 kHz, 50% duty cycle clock that is gapped to produce a 192 kHz nominal rate that is aligned with TOFP as shown in the timing diagram. TLDCLK is a 2.16 MHz, 67%(high)/33%(low) duty cycle clock that is gapped to produce a 576 kHz nominal rate that is aligned with TOFP as shown in the timing diagram. TSD (TLD) is sampled on the rising TSDCLK (TLDCLK) edge. The D1-D3, and D4-D12 bytes shifted into the STTX in the frame shown are inserted in the corresponding transport overhead channels in the following frame.

Fig. 19 Receive Data Link Clock and Data Alignment

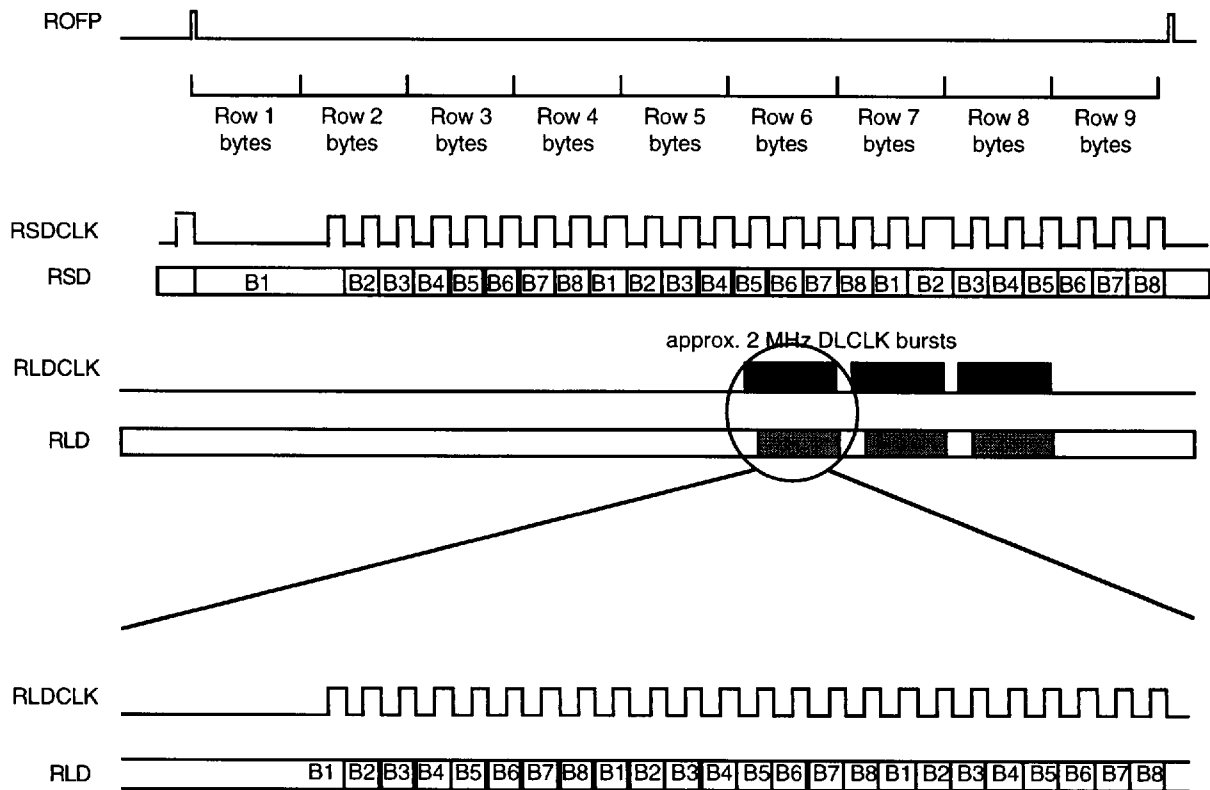

The receive data link clock and data alignment timing diagram (figure 19) shows the relationship between the RSD, and RLD serial data outputs, and their associated clocks, RSDCLK and RLDCLK. RSDCLK is a 216 kHz, 50% duty cycle clock that is gapped to produce a 192 kHz nominal rate that is aligned with ROFP as shown in the timing diagram. RLDCLK is a 2.16 MHz, 67%(high)/33%(low) duty cycle clock that is gapped to produce a 576 kHz nominal rate that is aligned with ROFP as shown in the timing diagram. RSD (RLD) is updated on the falling RSDCLK (RLDCLK) edge. The D1-D3, and D4-D12 bytes shifted out of the STTX in the frame shown are extracted from the corresponding receive line overhead channels in the previous frame.

Fig. 20 B1 and B2 Error Event Occurrence

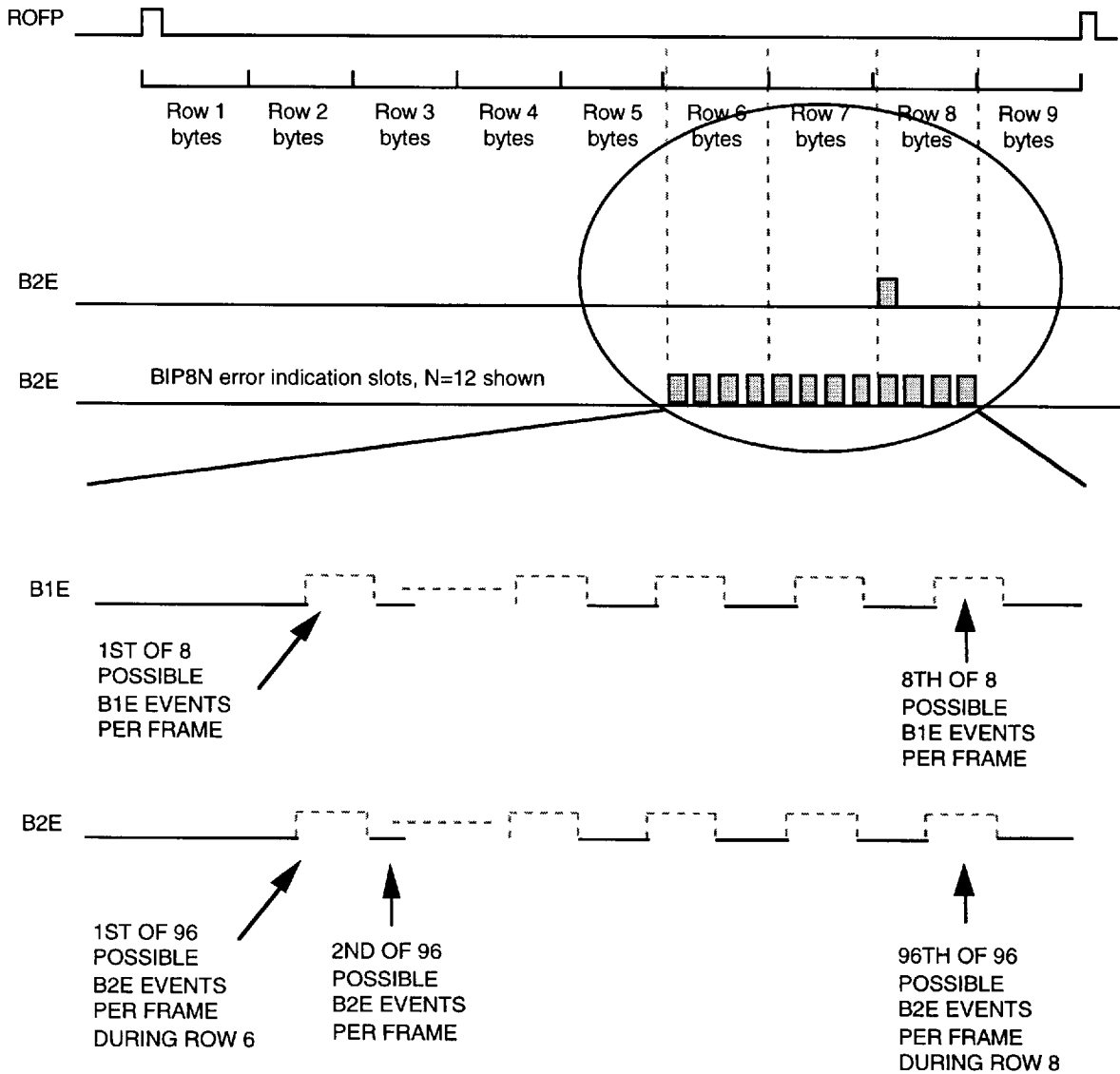

The B1 and B2 Error Event Occurrence timing diagram (figure 20) shows the location of B1 and B2 error events in an STS-12 frame. Up to 8 B1 errors and 96 B2 errors may be detected per frame. The B1 and B2 error clocks, B1E and B2E, pulse once for every B1 and B2 error detected. These signals may be used to accumulate B1 and B2 errors externally.

Fig. 21 Transport Overhead Extraction

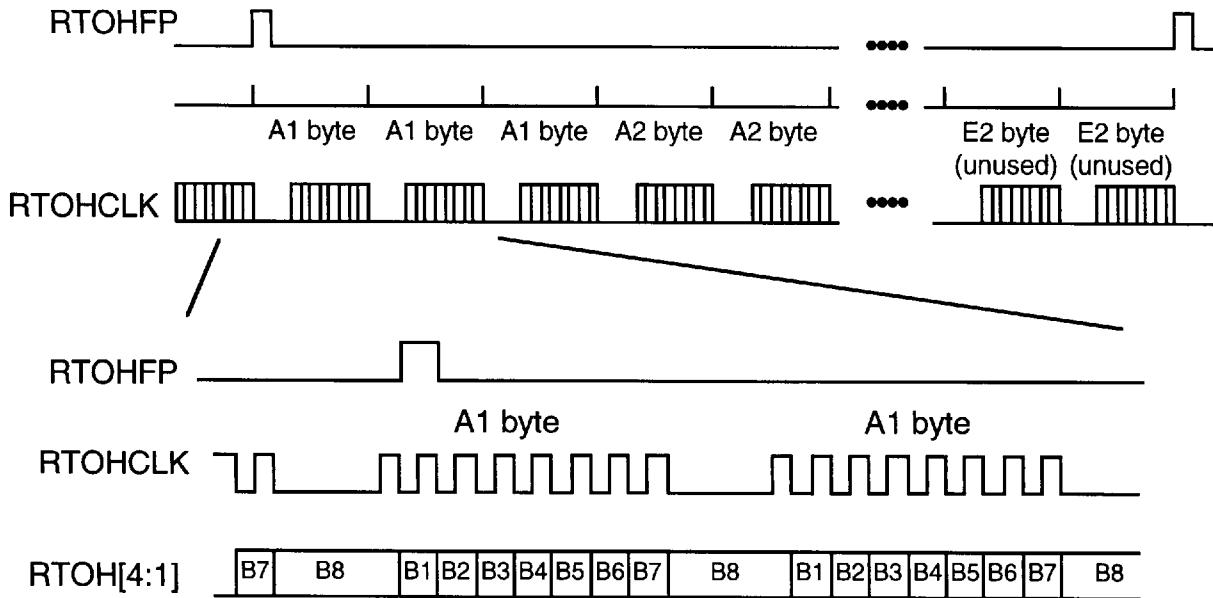

The transport overhead extraction timing diagram (figure 21) illustrates the transport overhead extraction interface. The transport overhead extraction clock, RTOHCLK is nominally a 5.184 MHz clock (1.728 MHz for an STS-1 stream), and is derived from the receive line clock, RICLK. The entire transport overhead (the complete 9 row by 9 column structure) is extracted for each STS-3 stream, and is serialized on RTOH[4:1] over a frame period (125 μ s). RTOH[1] contains the STS-3 or STS-1 TOH for the low speed stream ROUT1[7:0]. RTOH[2] contains the STS-3 TOH for the low speed stream ROUT2[7:0]. RTOH[3] contains the STS-3 TOH for the low speed stream ROUT3[7:0]. RTOH[4] contains the STS-3 TOH for the low speed stream ROUT4[7:0].

Fig. 22 Transport Overhead Insertion

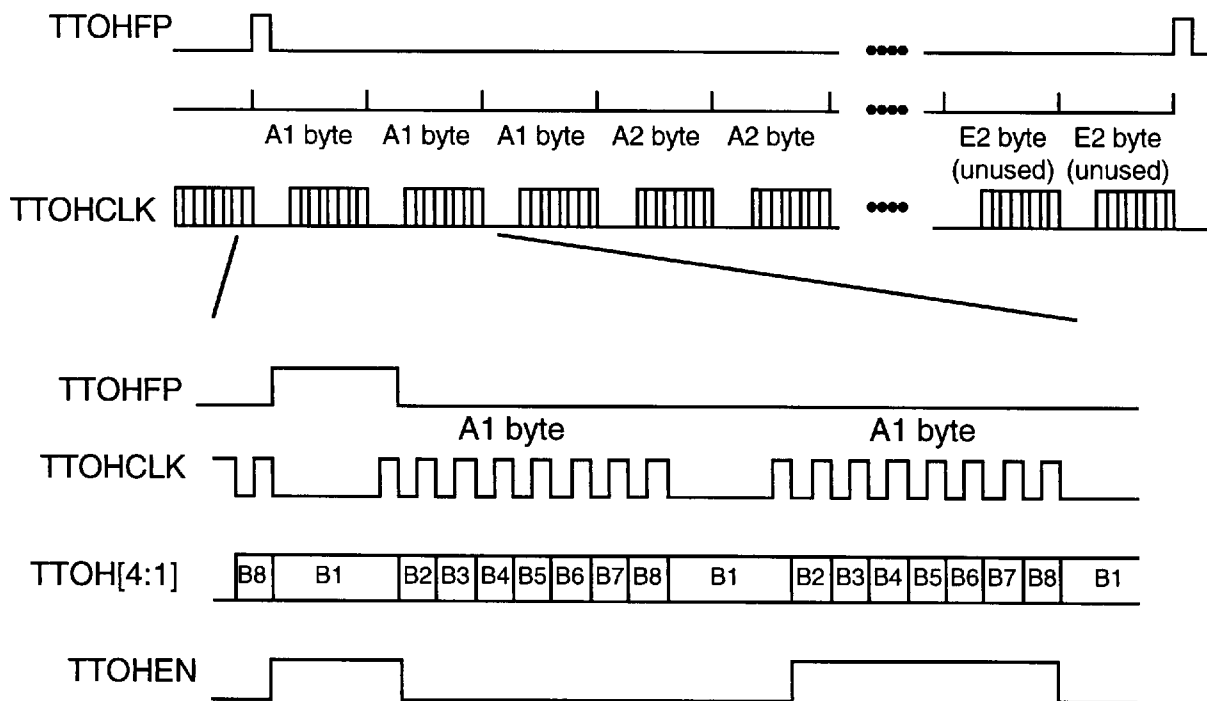

The transport overhead insertion timing diagram (figure 22) illustrates the transport overhead insertion interface. Output TTOHCLK is nominally a 5.184 MHz clock (1.728 MHz for an STS-1 stream), and is used to update output TTOHFP, and to sample inputs TTOH[4:1] and TTOHEN. It is assumed that the TDIS input is held low. A high level on TDIS takes precedence over the transport overhead insertion interface. The value sampled on TTOHEN during the first overhead bit position of a given set of overhead bytes determines whether the values sampled on TTOH[4:1] are inserted in the STS-N stream. In figure 22, TTOHEN is held high during the bit 1 position of the first group of four A1 bytes in the TTOH[4:1] stream. The eight bit values sampled on input TTOH[4:1] during the first A1 byte period are inserted in the first through fourth A1 byte positions in the STS-12 (STM-4) stream. Similarly, TTOHEN is held low during the bit 1 position of the second group of four A1 bytes. The default value (F6H) is inserted in the fifth through eighth A1 byte positions in the STS-12 (STM-4) stream.

An error insertion feature is also provided for the B1, H1, H2, and B2 byte positions. When TTOH[4:1] is held high during any of the bit positions corresponding to these bytes, the corresponding bit is inverted before being inserted in the STS-12 (STM-4) stream (TTOHEN must be sampled high during the first bit position to enable the error insertion mask).

Fig. 23 Transmit Ring Control Port

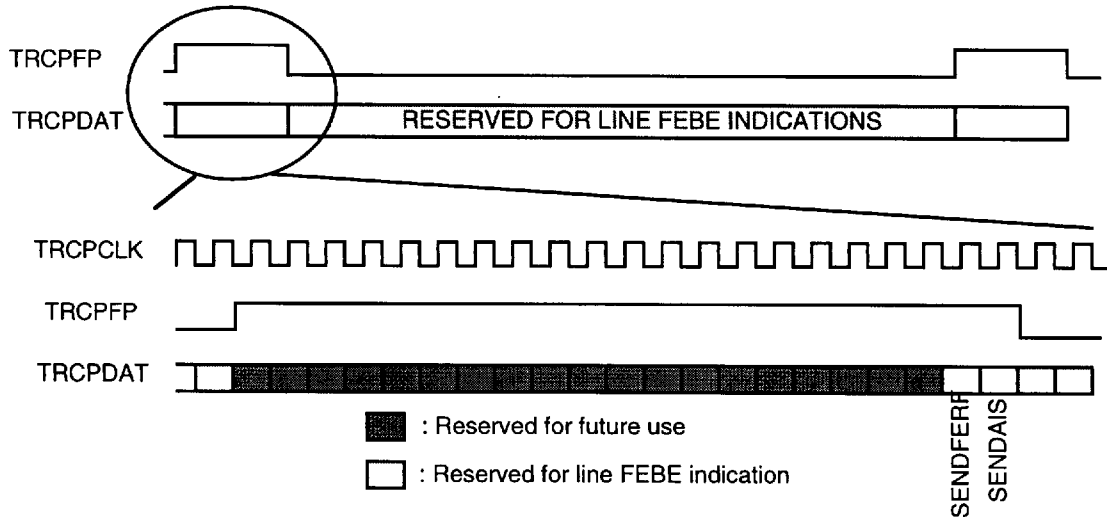

The Transmit Ring Control Port timing diagram (figure 23) illustrates the operation of the transmit ring control port when the ring control ports are enabled (using the RCP bit in the STTX Control/Enable Register). The control port timing is provided by the TRCPCLK input. TRCPFP and TRCPDAT are sampled on the rising edge of TRCPCLK. TRCPFP is used to distinguish the bit positions carrying maintenance signal control information (TRCPFP is high) from the bit positions carrying line FEBE indications (TRCPFP is low). TRCPFP is high for 21 bit positions once per frame 125 μs). Currently, only the last two bit positions are used. These bit positions control the insertion of line FERF and line AIS maintenance signals as illustrated in fig. 23. The remaining 19 bit positions are reserved for future STTX feature enhancements.

Fig. 24 Receive Ring Control Port

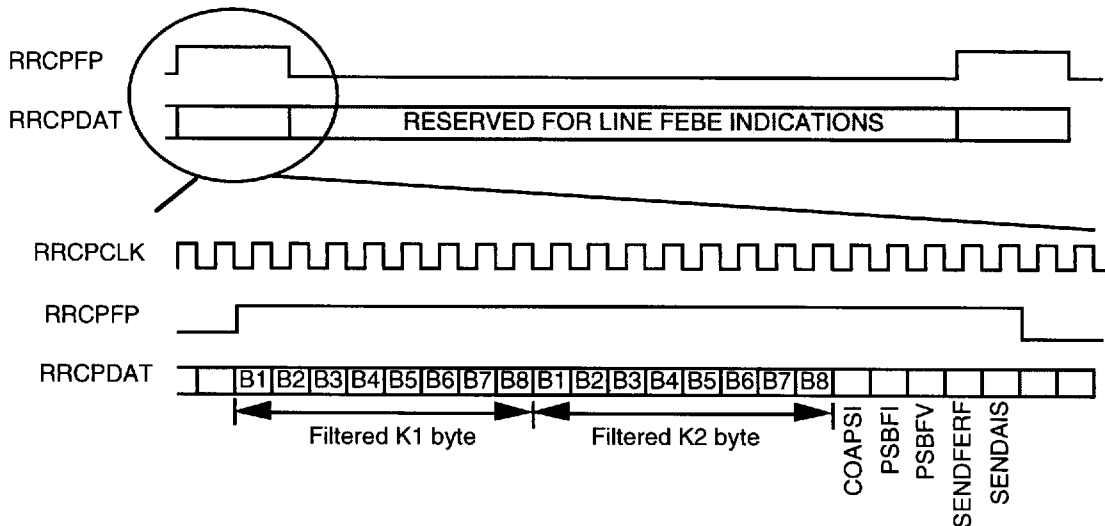

The Receive Ring Control Port timing diagram (figure 24) illustrates the operation of the receive ring control port when the ring control ports are enabled (using the RCP bit in the STTX Control/Enable Register). The control port timing is provided by the RRCPClk input. RRCPPFP and RRCPCDAT are updated on the falling edge of RRCPClk. RRCPPFP is used to distinguish the bit positions carrying alarm status and maintenance signal control information (RRCPPFP is high) from the bit positions carrying line FEBE indications (RRCPPFP is low). RRCPPFP is high for 21 bit positions once per frame 125 μ s).

The first 16 bit positions contain the APS channel byte values after filtering (the K1 and K2 values have been identical for at least three consecutive frames). The 17th bit position, COAPSI, is high for one frame when a new APS channel byte value (after filtering) is received. The 18th and 19th bit positions contain the current protection switch byte failure alarm status. PSBFI is high for one frame when a change in the protection switch byte failure alarm state is detected. PSBFV contains the real-time active high state value of the protection switch byte failure alarm. The 20th and 21st bit positions control the insertion of the line AIS and line FERF maintenance signals in a mate STTX. The SENDFERF bit position is controlled by the logical OR of the loss of signal, loss of frame or line AIS alarms, or by the SFERF bit in the Ring Control Register. The SENDAIS bit position is controlled by the SAIS bit in the Ring Control Register.

ABSOLUTE MAXIMUM RATINGS

Case Temperature under Bias	-40°C to +85°C
Storage Temperature	-40°C to +125°C
Supply Voltage	-0.5V to +6.0V
Voltage on Any Pin	-0.5V to $V_{DD}+0.5V$
Static Discharge Voltage	±500V
Latch-Up Current	±100 mA
DC Input Current	±20 mA
Lead Temperature	+300°C
Absolute Maximum Junction Temperature	+150°C
Power Dissipation	2.5 W

D.C. CHARACTERISTICS(T_C = -40°C to T_C = +85°C, V_{DD} = 5 V ±10%)

Symbol	Parameter	Min	Typ	Max	Units	Conditions
V _{IL}	Input Low Voltage	-0.5		0.8	Volts	Guaranteed Input LOW Voltage
V _{IH}	Input High Voltage	2.0		V _{DD} +0.5	Volts	Guaranteed Input HIGH Voltage
V _{OL}	Output or Bidirectional Low Voltage			0.4	Volts	V _{DD} = min, I _{OL} = 4 mA, Note 3
V _{OH}	Output or Bidirectional High Voltage	2.4			Volts	V _{DD} = min, I _{OH} = 4 mA, Note 3
V _{T+}	Reset Input High Voltage	3.5			Volts	
V _{T-}	Reset Input Low Voltage			0.8	Volts	
V _{TH}	Reset Input Hysteresis Voltage		0.5		Volts	
I _{ILPU}	Input Low Current	+20		+200	μA	V _{IL} = GND, Notes 1, 3
I _{IHPU}	Input High Current	-10	0	+10	μA	V _{IH} = V _{DD} , Notes 1, 3
I _{ILPD}	Input Low Current	-10	0	+10	μA	V _{IL} = GND, Notes 4, 3
I _{IHPD}	Input High Current	-200		-20	μA	V _{IH} = V _{DD} , Notes 4, 3
I _{IL}	Input Low Current	-10	0	+10	μA	V _{IL} = GND, Notes 2, 3
I _{IH}	Input High Current	-10	0	+10	μA	V _{IH} = V _{DD} , Notes 2, 3

C _{IN}	Input Capacitance		5		pF	Excluding Package, Package Typically 2 pF for PQFP, 6 pF for CPGA
C _{OUT}	Output Capacitance		5		pF	Excluding Package, Package Typically 2 pF for PQFP, 6 pF for CPGA
C _{IO}	Bidirectional Capacitance		5		pF	Excluding Package, Package Typically 2 pF for PQFP, 6 pF for CPGA
I _{DDOP12}	Operating Current STS-12 Mode Enabled		214	255	mA	V _{DD} = 5.5 V, Outputs Unloaded, R _{ICLK} , T _{CLK} = 77.76 MHz, Random Data (V _{DD} =5.0V for Typical)
I _{DDOP3}	Operating Current STS-3 Mode Enabled		50	74	mA	V _{DD} = 5.5 V, Outputs Unloaded, R _{ICLK} , T _{CLK} = 19.44 MHz, Random Data (V _{DD} =5.0V for Typical)
I _{DDOP1}	Operating Current STS-1 Mode Enabled		33	42	mA	V _{DD} = 5.5 V, Outputs Unloaded, R _{SICLK} , T _{SICLK} = 51.84 MHz, Random Data (V _{DD} =5.0V for Typical)

Notes on D.C. Characteristics:

1. Input pin or bidirectional pin with internal pull-up resistor.
2. Input pin or bidirectional pin without internal pull-up resistor
3. Negative currents flow into the device (sinking), positive currents flow out of the device (sourcing).
4. Input pin or bidirectional pin with internal pull-down resistor.

MICROPROCESSOR INTERFACE TIMING CHARACTERISTICS

($T_C = -40^\circ\text{C}$ to $T_C = +85^\circ\text{C}$, $V_{DD} = 5\text{ V} \pm 10\%$)

Microprocessor Interface Read Access (Fig. 25)

Symbol	Parameter	Min	Max	Units
t _{SAR}	Address to Valid Read Set-up Time	25		ns
t _{HAR}	Address to Valid Read Hold Time	20		ns
t _{SALR}	Address to Latch Set-up Time	20		ns
t _{HALR}	Address to Latch Hold Time	20		ns
t _{VL}	Valid Latch Pulse Width	20		ns
t _{SLR}	Latch to Read Set-up	0		ns
t _{HLR}	Latch to Read Hold	20		ns
t _{PRD}	Valid Read to Valid Data Propagation Delay		80	ns
t _{ZRD}	Valid Read Negated to Output Tri-state		20	ns
t _{ZINTH}	Valid Read Negated to Output Tri-state		50	ns

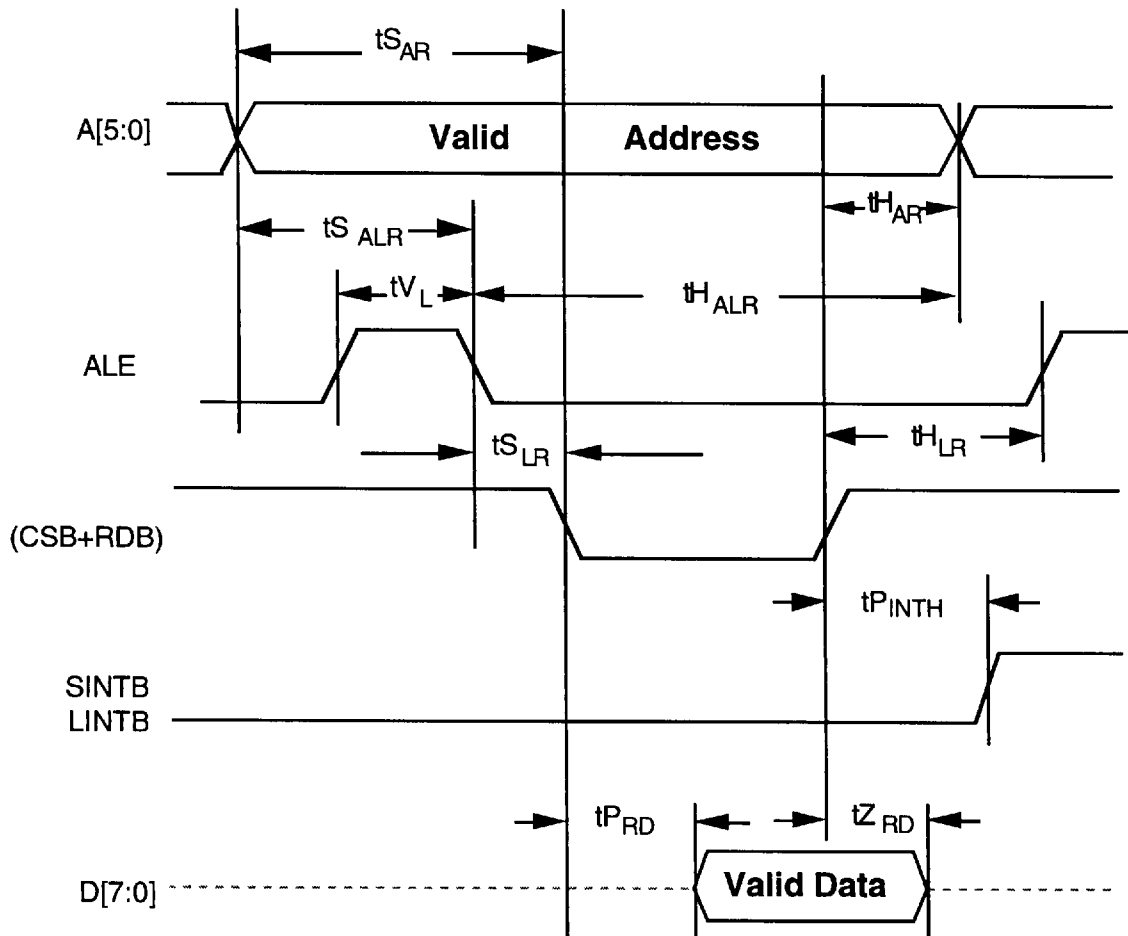
Fig. 25 Microprocessor Interface Read Access Timing**Notes on Microprocessor Interface Read Timing:**

1. Output propagation delay time is the time in nanoseconds from the 1.4 Volt point of the reference signal to the 1.4 Volt point of the output.
2. Maximum output propagation delays are measured with a 100 pF load on the Microprocessor Interface data bus, (D[7:0]).
3. A valid read cycle is defined as a logical OR of the CSB and the RDB signals.
4. Microprocessor Interface timing applies to normal mode register accesses only.
5. In non-multiplexed address/data bus architectures, ALE should be held high, parameters $t_{S_{ALR}}$, $t_{H_{ALR}}$, t_{V_L} , and $t_{S_{LR}}$ are not applicable.
6. Parameter $t_{H_{AR}}$ and $t_{S_{AR}}$ are not applicable if address latching is used.

7. When a set-up time is specified between an input and a clock, the set-up time is the time in nanoseconds from the 1.4 Volt point of the input to the 1.4 Volt point of the clock.
8. When a hold time is specified between an input and a clock, the hold time is the time in nanoseconds from the 1.4 Volt point of the clock to the 1.4 Volt point of the input.

Microprocessor Interface Write Access (Fig. 26)

Symbol	Parameter	Min	Max	Units
t _{SAW}	Address to Valid Write Set-up Time	25		ns
t _{SDW}	Data to Valid Write Set-up Time	20		ns
t _{SALW}	Address to Latch Set-up Time	20		ns
t _{HALW}	Address to Latch Hold Time	20		ns
t _{VL}	Valid Latch Pulse Width	20		ns
t _{SLW}	Latch to Write Set-up	0		ns
t _{HLW}	Latch to Write Hold	20		ns
t _{HDW}	Data to Valid Write Hold Time	20		ns
t _{HAW}	Address to Valid Write Hold Time	20		ns
t _{VWR}	Valid Write Pulse Width	40		ns

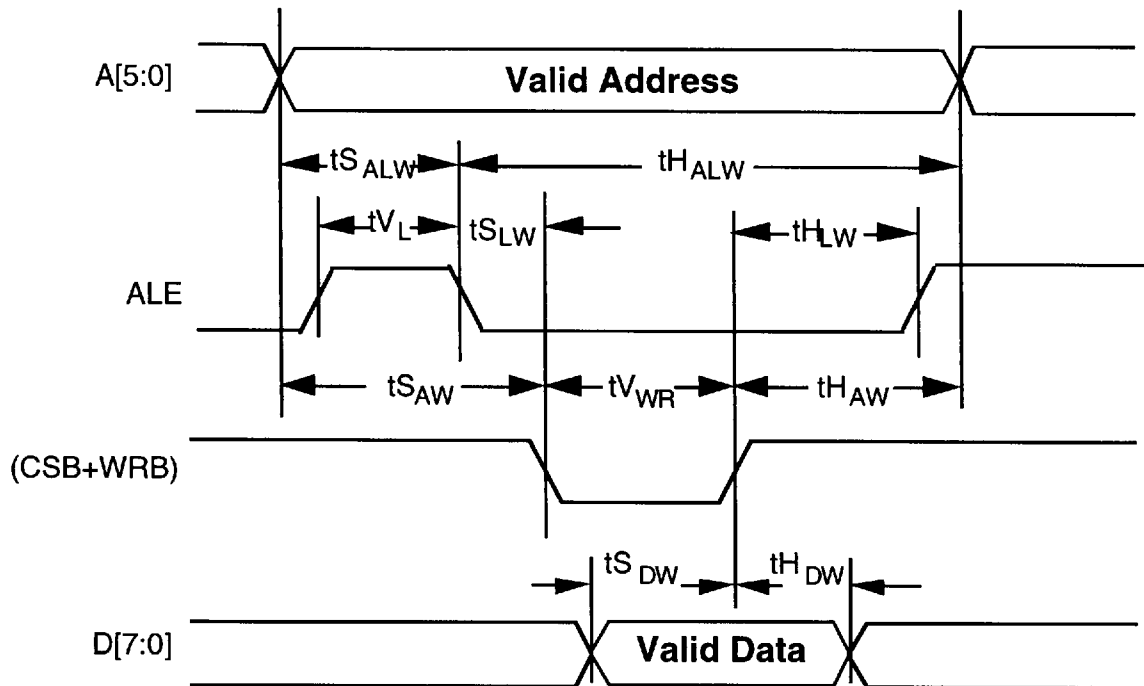
Fig. 26 Microprocessor Interface Write Access Timing**Notes on Microprocessor Interface Write Timing:**

1. A valid write cycle is defined as a logical OR of the CSB and the WRB signals.
2. Microprocessor timing applies to normal mode register accesses only.
3. In non-multiplexed address/data bus architectures, ALE should be held high, parameters t_{S_ALW} , t_{H_ALW} , t_{V_L} , and t_{S_LW} are not applicable.
4. Parameters t_{H_AW} and t_{S_AW} are not applicable if address latching is used.
5. Output propagation delay time is the time in nanoseconds from the 1.4 Volt point of the reference signal to the 1.4 Volt point of the output.
6. When a set-up time is specified between an input and a clock, the set-up time is the time in nanoseconds from the 1.4 Volt point of the input to the 1.4 Volt point of the clock.
7. When a hold time is specified between an input and a clock, the hold time is the time in nanoseconds from the 1.4 Volt point of the clock to the 1.4 Volt point of the input.

STTX TIMING CHARACTERISTICS

($T_C = -40^\circ\text{C}$ to $T_C = +85^\circ\text{C}$, $V_{DD} = 5\text{ V} \pm 10\%$)

INPUT TIMING

Receive Input (Fig. 27)

Symbol	Description	Min	Max	Units
	RICK Frequency (nominally 6.48 MHz, 19.44 MHz, 77.76 MHz)		78	MHz
	RICK Duty Cycle	33	67	%
t _{SRIN}	RIN[7:0] Set-up Time to RICK	1		ns
t _{HRIN}	RIN[7:0] Hold Time to RICK	3		ns
t _{SRLAIS}	RLAIS Set-up Time to RICK	1		ns
t _{HLAIS}	RLAIS Hold Time to RICK	3		ns
t _{SRIFP}	RIFP Set-Up Time to RICK	1		ns
t _{HRIFP}	RIFP Hold Time to RICK	3		ns

Fig. 27 Receive Input Timing

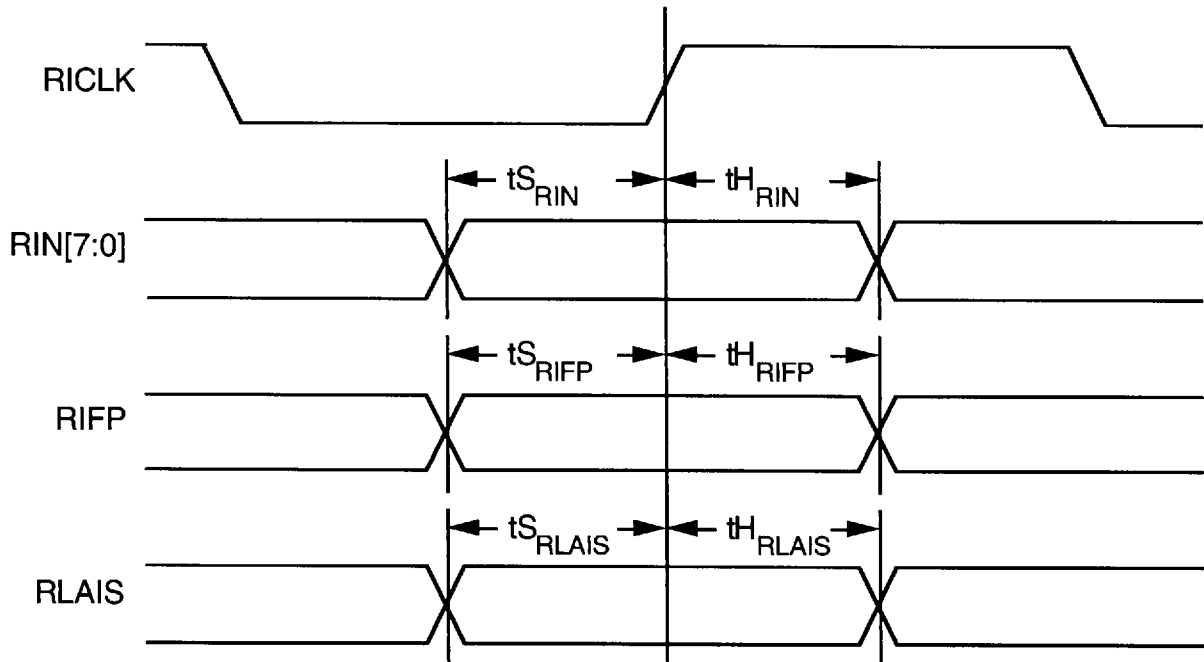

Transmit Input with BIMX Bypassed (Fig. 28)

Symbol	Description	Min	Max	Units
	TCLK Frequency (nominally 6.48 MHz 19.44 MHz)		20	MHz
	TCLK Duty Cycle	33	67	%
t _{STIN1}	TIN1[7:0] Set-up Time to TCLK	5		ns
t _{HTIN1}	TIN1[7:0] Hold Time to TCLK	5		ns
t _{STFPIN}	TIFP Set-Up Time to TCLK	5		ns
t _{HTFPIN}	TIFP Hold Time to TCLK	5		ns
t _{STDIS}	TDIS Set-up Time to TCLK	5		ns
t _{HTDIS}	TDIS Hold Time to TCLK	5		ns
t _{STFERF}	TFERF Set-up Time to TCLK	5		ns
t _{HTFERF}	TFERF Hold Time to TCLK	0		ns
t _{STLAIS}	TLAIS Set-up Time to TCLK	5		ns
t _{HTLAIS}	TLAIS Hold Time to TCLK	0		ns
t _{STLD}	TLD Set-up Time to TLDCLK	10		ns
t _{HTLD}	TLD Hold Time to TLDCLK	10		ns
t _{STSD}	TSD Set-up Time to TSDCLK	10		ns
t _{HTSD}	TSD Hold Time to TSDCLK	10		ns
t _{STOW}	TSOW Set-up Time to TOWCLK	10		ns
t _{HTOW}	TSOW Hold Time to TOWCLK	10		ns
t _{STUC}	TSUC Set-up Time to TOWCLK	10		ns
t _{HTUC}	TSUC Hold Time to TOWCLK	10		ns
t _{STOW}	TLOW Set-up Time to TOWCLK	10		ns
t _{HTOW}	TLOW Hold Time to TOWCLK	10		ns
t _{STAPS}	TAPS Set-up Time to TAPSCLK	10		ns
t _{HTAPS}	TAPS Hold Time to TAPSCLK	10		ns
t _{STTOH}	TTOHCLK Set-up Time to TTOH[4:1], TTOHEN	10		ns
t _{HTTOH}	TTOHCLK Hold Time to TTOH[4:1], TTOHEN	10		ns

Fig. 28 Transmit Input Timing with BIMX Bypassed

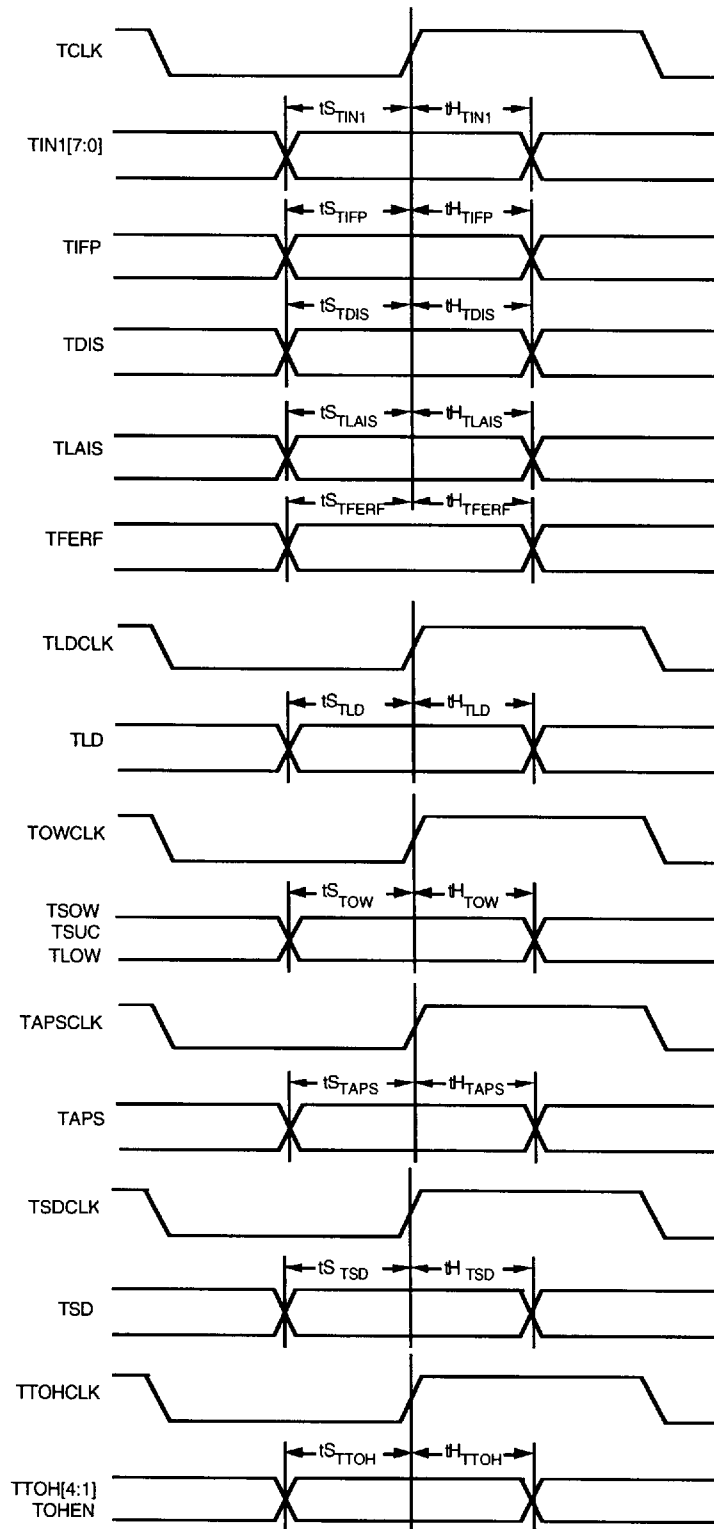

Transmit Input to BIMX (Fig. 29)

Symbol	Description	Min	Max	Units
	TCLK Frequency (nominally 19.44 MHz, or 77.76 MHz)		78	MHz
	TCLK Duty Cycle	33	67	%
	TICLK Frequency (nominally 6.48 MHz or 19.44 MHz)		20	MHz
	TICLK Duty Cycle	33	67	%
t _{STIN1}	TIN1[7:0] Set-up Time to TICLK	5		ns
t _{HTIN1}	TIN1[7:0] Hold Time to TICLK	5		ns
t _{STIN2}	TIN2[7:0] Set-up Time to TICLK	5		ns
t _{HTIN2}	TIN2[7:0] Hold Time to TICLK	5		ns
t _{STIN3}	TIN3[7:0] Set-up Time to TICLK	5		ns
t _{HTIN3}	TIN3[7:0] Hold Time to TICLK	5		ns
t _{STIN4}	TIN4[7:0] Set-up Time to TICLK	5		ns
t _{HTIN4}	TIN4[7:0] Hold Time to TICLK	5		ns
t _{STIFP}	TIFP Set-Up Time to TICLK	5		ns
t _{HTIFP}	TIFP Hold Time to TICLK	5		ns
t _{STDIS}	TDIS Set-up Time to TICLK	5		ns
t _{HTDIS}	TDIS Hold Time to TICLK	5		ns

Fig. 29 Transmit Input Timing to BIMX

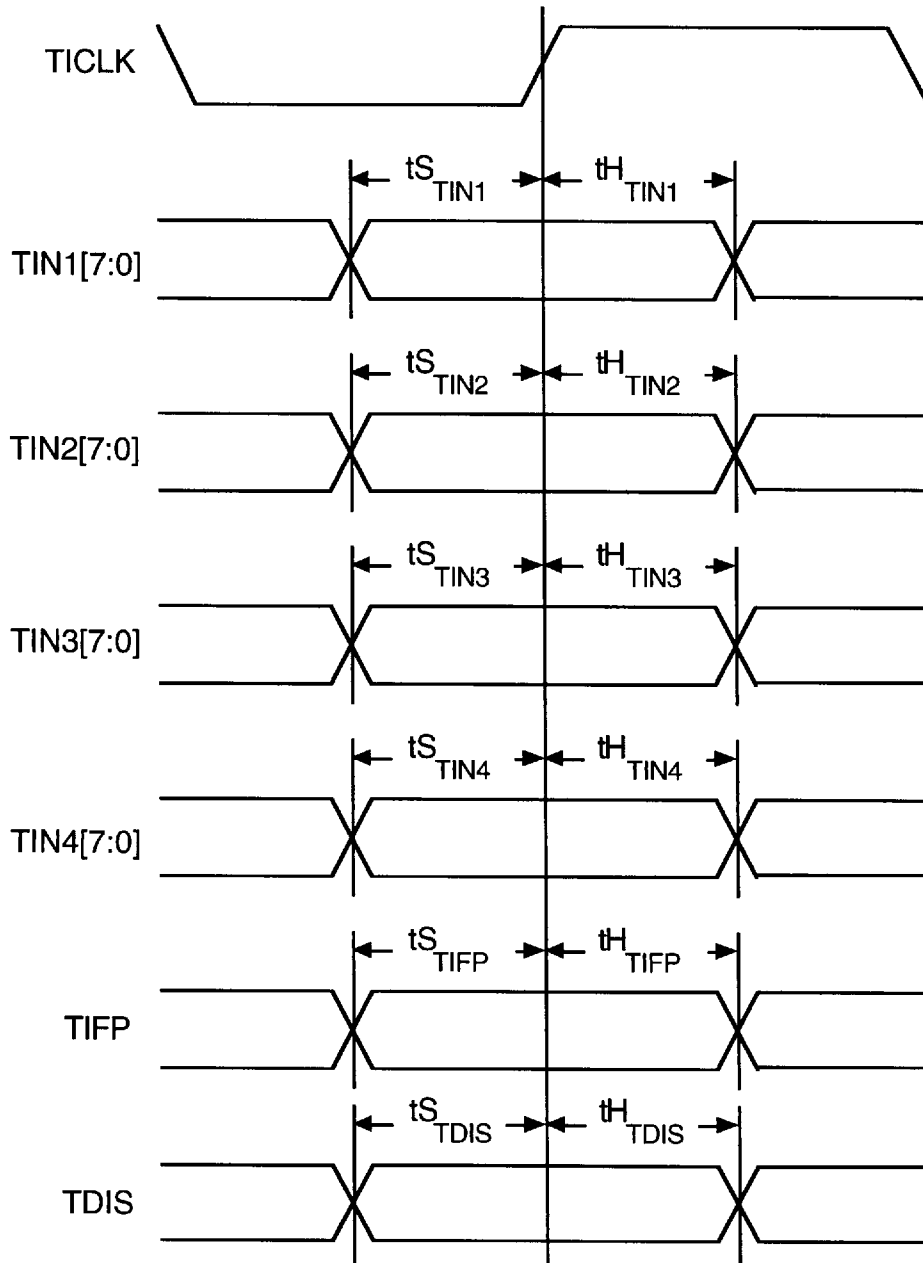

STS-1 Input (Fig. 30)

Symbol	Description	Min	Max	Units
	RSICLK Frequency (nominally 51.84 MHz)		52	MHz
	RSICLK Duty Cycle	33	67	%
	TSICLK Frequency (nominally 51.84 MHz)		52	MHz
	TSICLK Duty Cycle	33	67	%
t _{STSIN}	RSIN Set-up Time to RSICLK	1		ns
t _{HTSIN}	RSIN Hold Time to RSICLK	4		ns

Fig. 30 STS-1 Input

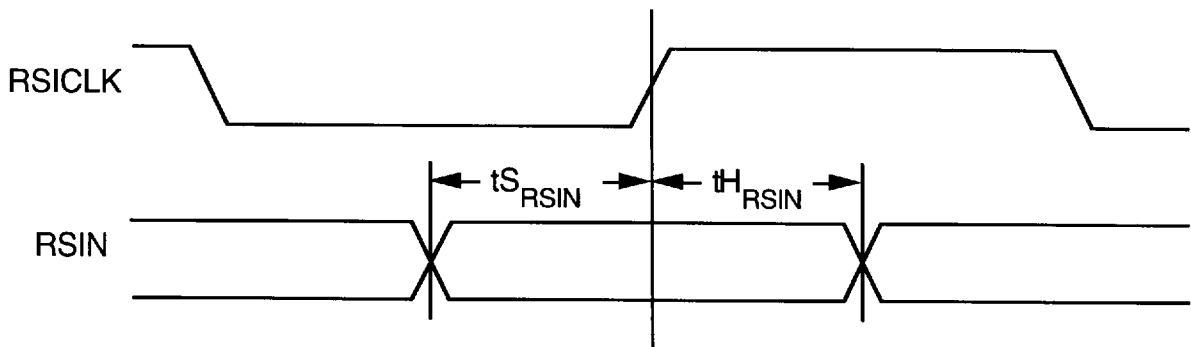

Transmit Ring Control Port Input (Fig. 31)

Symbol	Description	Min	Max	Units
	TRCPCLK Frequency (nominally 3.24 MHz)		4	MHz
	TRCPCLK Duty Cycle	33	67	%
t _{STRCPFP}	TRCPFP Set-up Time to TRCPCLK	10		ns
t _{HTRCPFP}	TRCPFP Hold Time to TRCPCLK	10		ns
t _{STRCPD}	TRCPDAT Set-up Time to TRCPCLK	10		ns
t _{HTRCPD}	TRCPDAT Hold Time to TRCPCLK	10		ns

Fig. 31 Transmit Ring Control Port Input

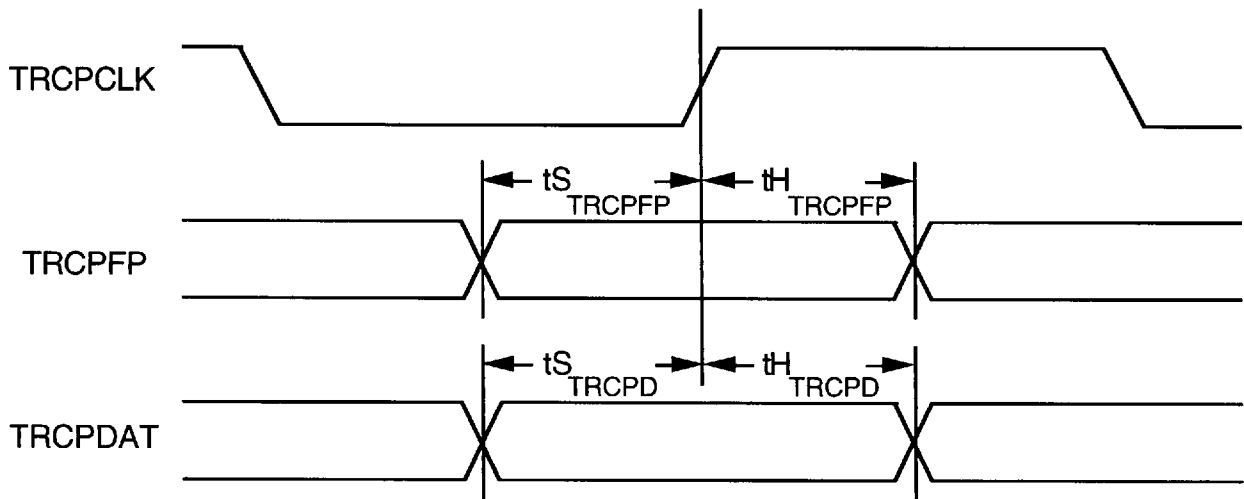

Notes on Input Timing:

1. When a set-up time is specified between an input and a clock, the set-up time is the time in nanoseconds from the 1.4 Volt point of the input to the 1.4 Volt point of the clock.
2. When a hold time is specified between an input and a clock, the hold time is the time in nanoseconds from the 1.4 Volt point of the clock to the 1.4 Volt point of the input.

OUTPUT TIMING

Receive Output Timing with BIDX Bypassed (Fig. 32)

Symbol	Description	Min	Max	Units
tPROUT1	RICK High to ROUT1[7:0] Valid Prop Delay	5	30	ns
tPROFP	RICK High to ROFP Valid Prop Delay	5	30	ns
tPRALM	RICK High to OOF, LOF, LOS, LAIS, FERF Valid Prop Delay	5	30	ns
tPRLD	RLDCLK Low to RLD Valid Prop Delay	-5	20	ns
tPRSD	RSDCLK Low to RSD Valid Prop Delay	-5	20	ns
tPROW	ROWCLK Low to RSOW, RSUC, RLOW Valid Prop Delay	-250	250	ns
tPRAPS	RAPSCLK Low to RAPS Valid Prop Delay	-5	20	ns
tPRTOH	RTOHCLK Low to RTOH[4:1] and RTOHFP Valid Prop Delay	-5	20	ns

Fig. 32 Receive Output Timing with BIDX Bypassed

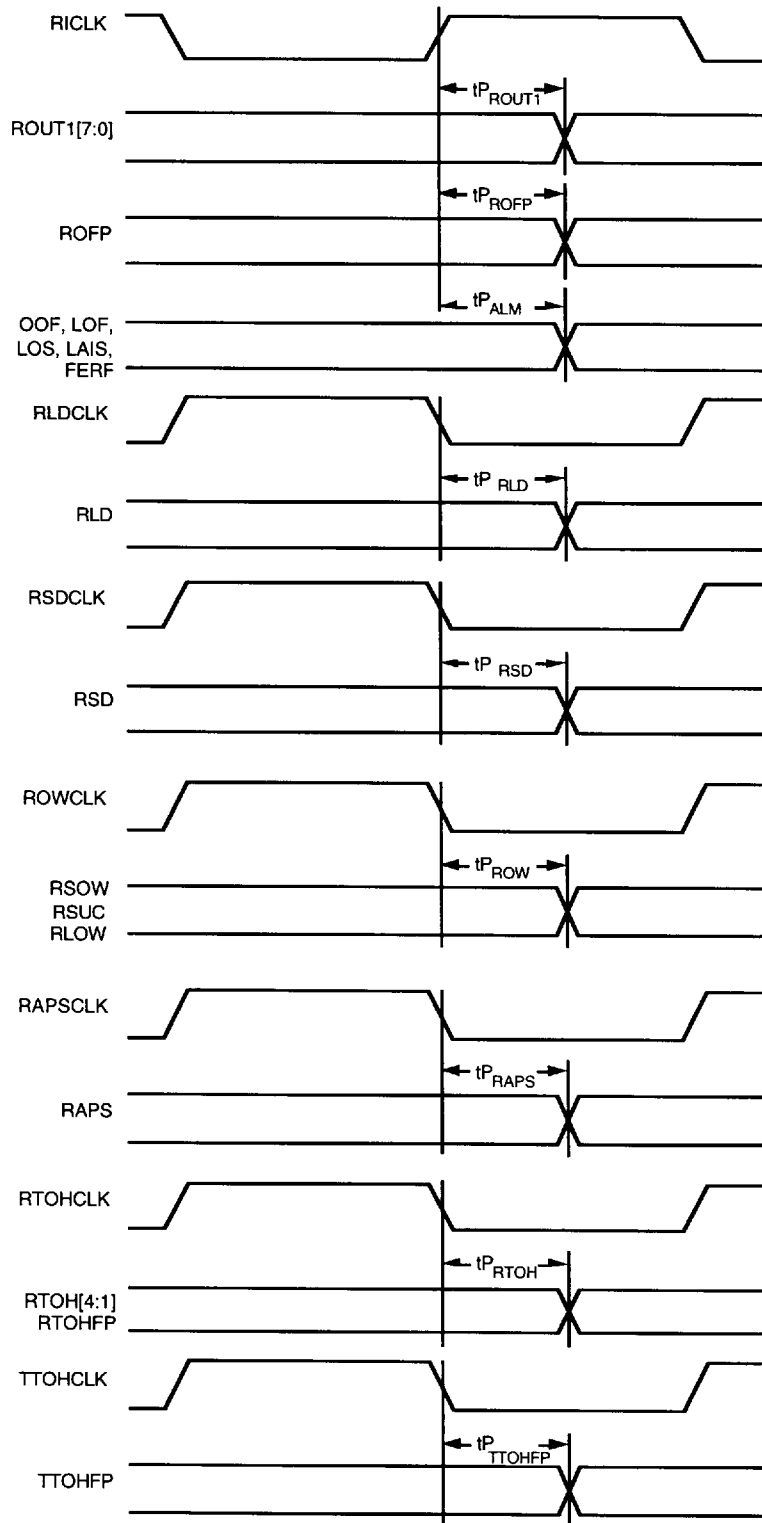

Receive Output of BIDX (Fig. 33)

Symbol	Description	Min	Max	Units
tP _{ROUT1}	ROCLK Low to ROUT1[7:0] Valid Prop Delay	-5	10	ns
tP _{ROUT2}	ROCLK Low to ROUT2[7:0] Valid Prop Delay	-5	10	ns
tP _{ROUT3}	ROCLK Low to ROUT3[7:0] Valid Prop Delay	-5	10	ns
tP _{ROUT4}	ROCLK Low to ROUT4[7:0] Valid Prop Delay	-5	10	ns
tP _{ROFP}	ROCLK Low to ROFP Valid Prop Delay	-5	10	ns

Fig. 33 Receive Output Timing of BIDX

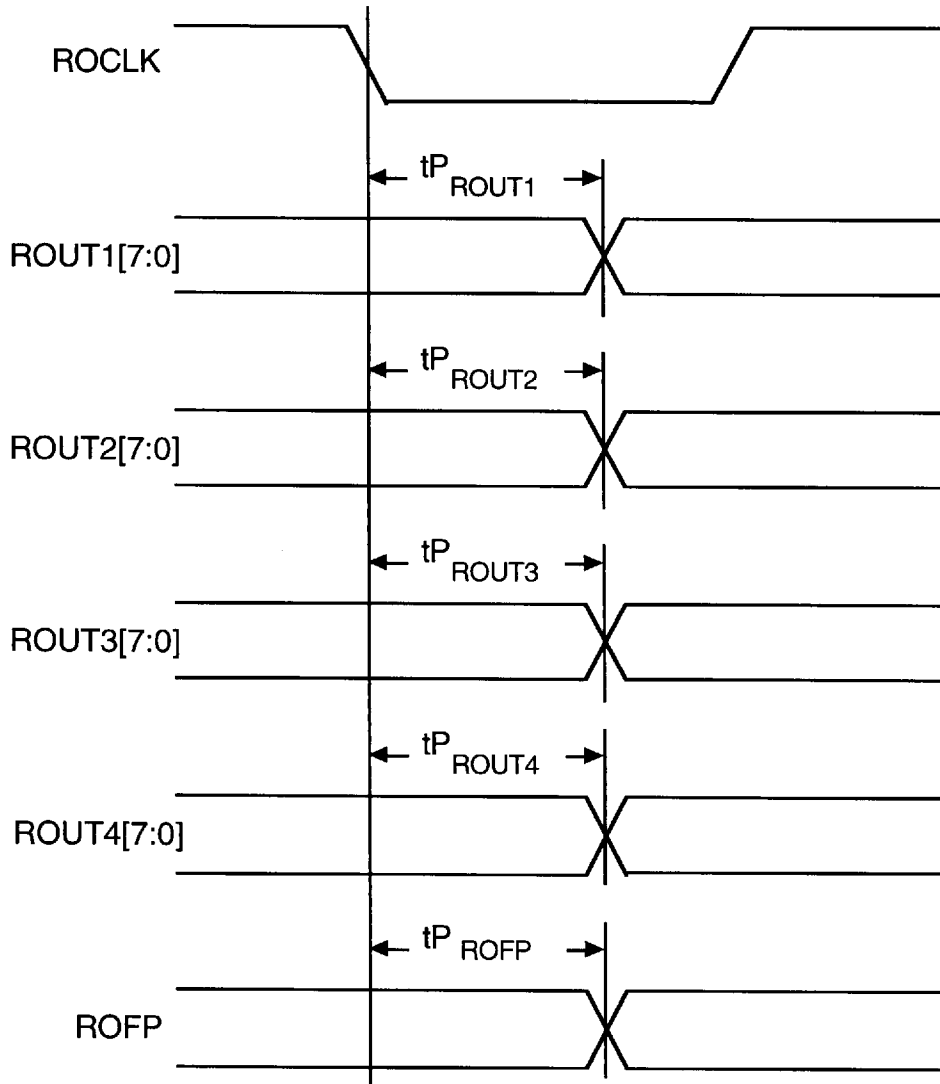

Transmit Output of TLOP (Fig. 34)

Symbol	Description	Min	Max	Units
tP _{TOUT}	TCLK High to TOUT[7:0] Valid Prop Delay	2	11	ns
tP _{GTICKL}	TCLK High to GTICKL Valid Prop Delay	2	20	ns
tP _{TOFP}	TCLK High to TOFP Valid Prop Delay	2	11	ns

Fig. 34 Transmit Output Timing

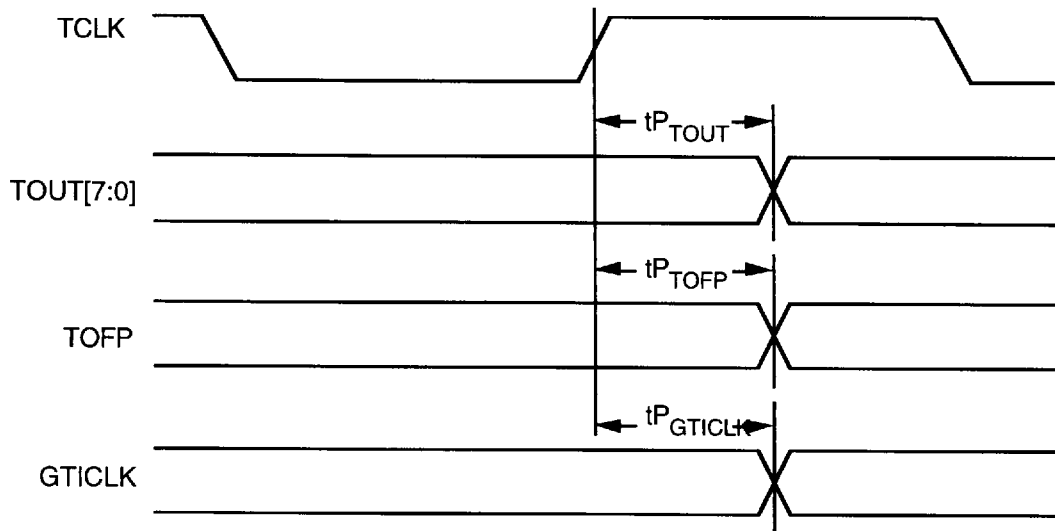

STS-1 Output (Fig. 35)

Symbol	Description	Min	Max	Units
tP_{TSOUT}	TSICLK High to TSOUT Valid Prop Delay	2	15	ns
tP_{GTICLK}	TSICLK High to GTICLK Valid Prop Delay	4	20	ns
tP_{GBCLK}	RSICLK High to ROCLK Valid Prop Delay	5	30	ns

Fig. 35 STS-1 Output Timing

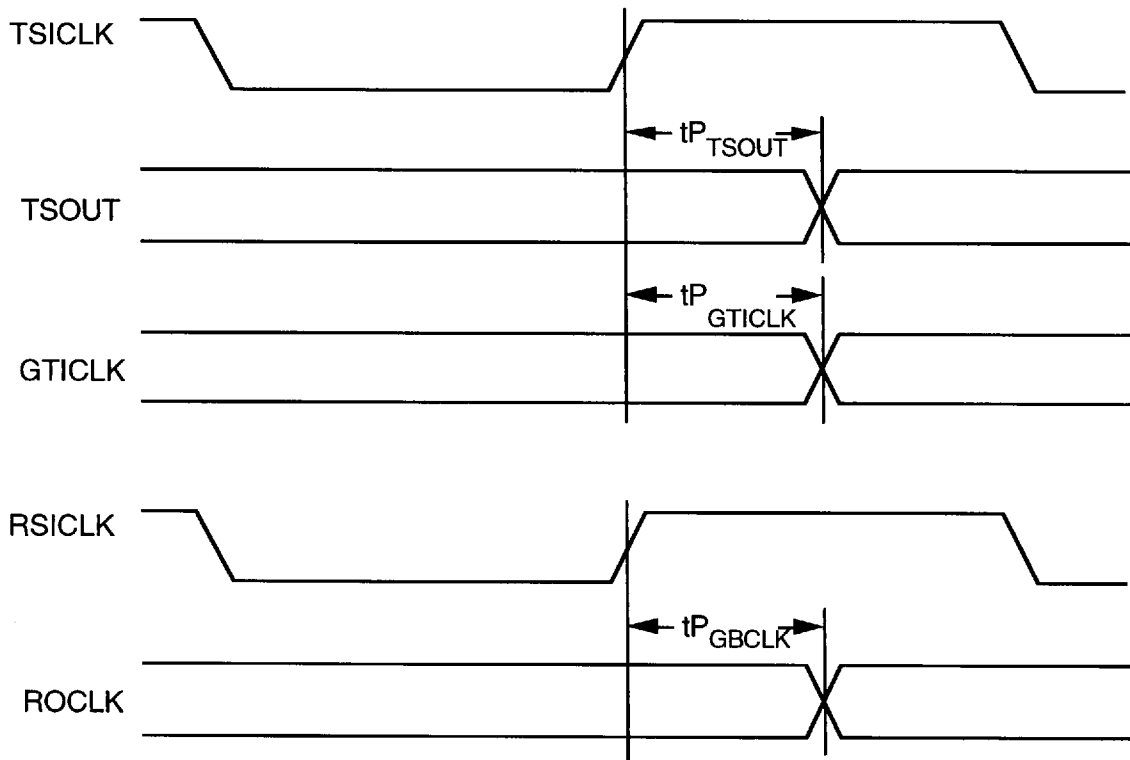

Receive Ring Control Port Output (Fig. 36)

Symbol	Description	Min	Max	Units
$t_{P_{RRCFP}}$	RRCCLK High to RRCFPF Valid Prop Delay	-5	20	ns
$t_{P_{RRCPD}}$	RRCCLK High to RRCPDAT Valid Prop Delay	-5	20	ns

Fig. 36 Ring Control Port Output

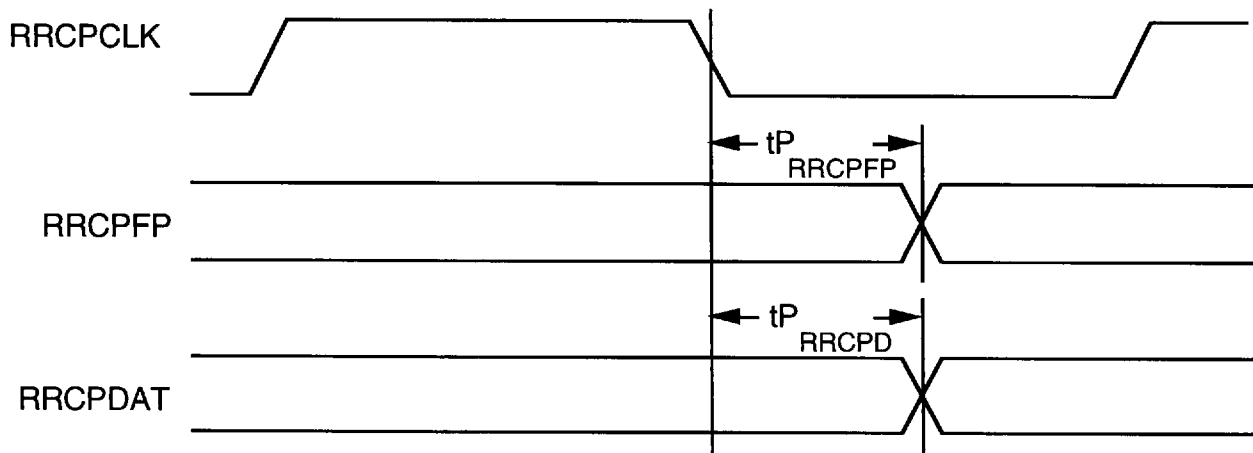

Notes on Output Timing:

1. Output propagation delay time is the time in nanoseconds from the 1.4 Volt point of the reference signal to the 1.4 Volt point of the output.
2. Output propagation delays are specified with a 50 pF load on the outputs, except in the case of tPTOUT and tPTSOUT where propagation delays are specified with a 30pF load on the outputs.
3. For aid in computing propagation delays under different loading conditions, a de-rating curve for tPTOUT for "typical" devices is shown below. This curve is based on characterization data. Any point along a line in the curve is equivalent to any other point on the line. For example a maximum propagation delay of 11ns into 30pF is equivalent to a maximum propagation delay of 10ns into 10pF.

Equivalent Specification for tPTOUT

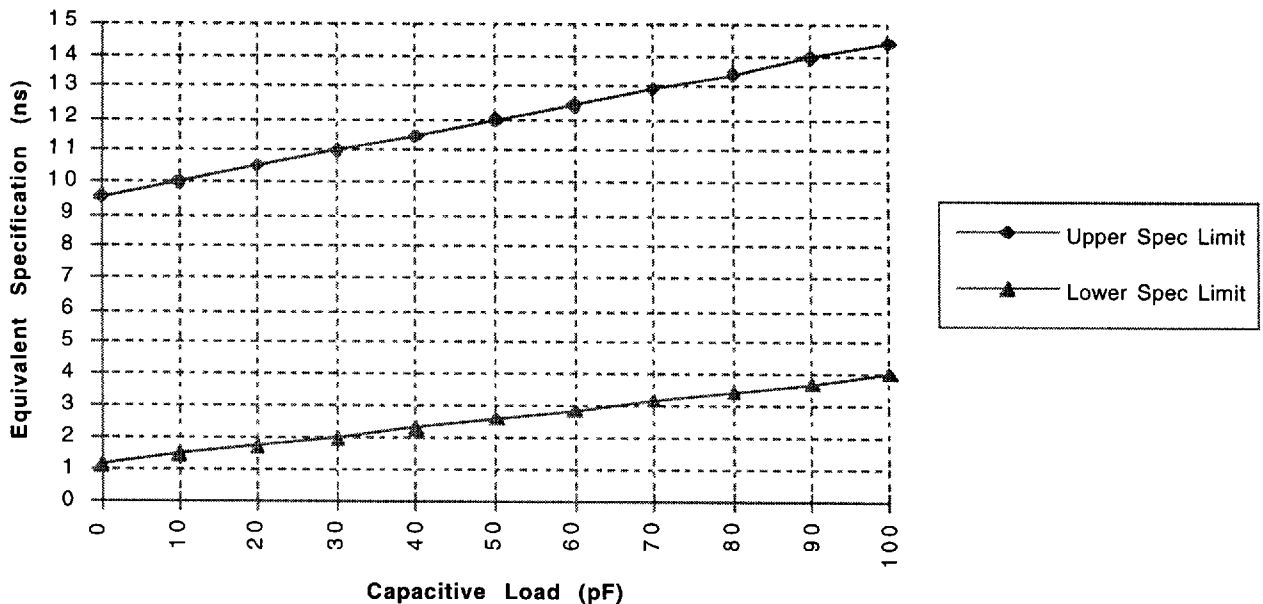

ORDERING AND THERMAL INFORMATION

PART NO.	DESCRIPTION
PM5312-GI	180 Ceramic Pin Grid Array (CPGA)
PM5312-SI	208 Slugged Plastic Quad Flat Pack (PQFP)

PART NO.	CASE TEMPERATURE	Theta Ja	Theta Jc
PM5312-GI	-40°C to 85°C	31 °C/W	8 °C/W
PM5312-SI	-40°C to 85°C	24 °C/W	8 °C/W

MECHANICAL INFORMATION

180 Pin Ceramic Pin Grid Array (G Suffix):

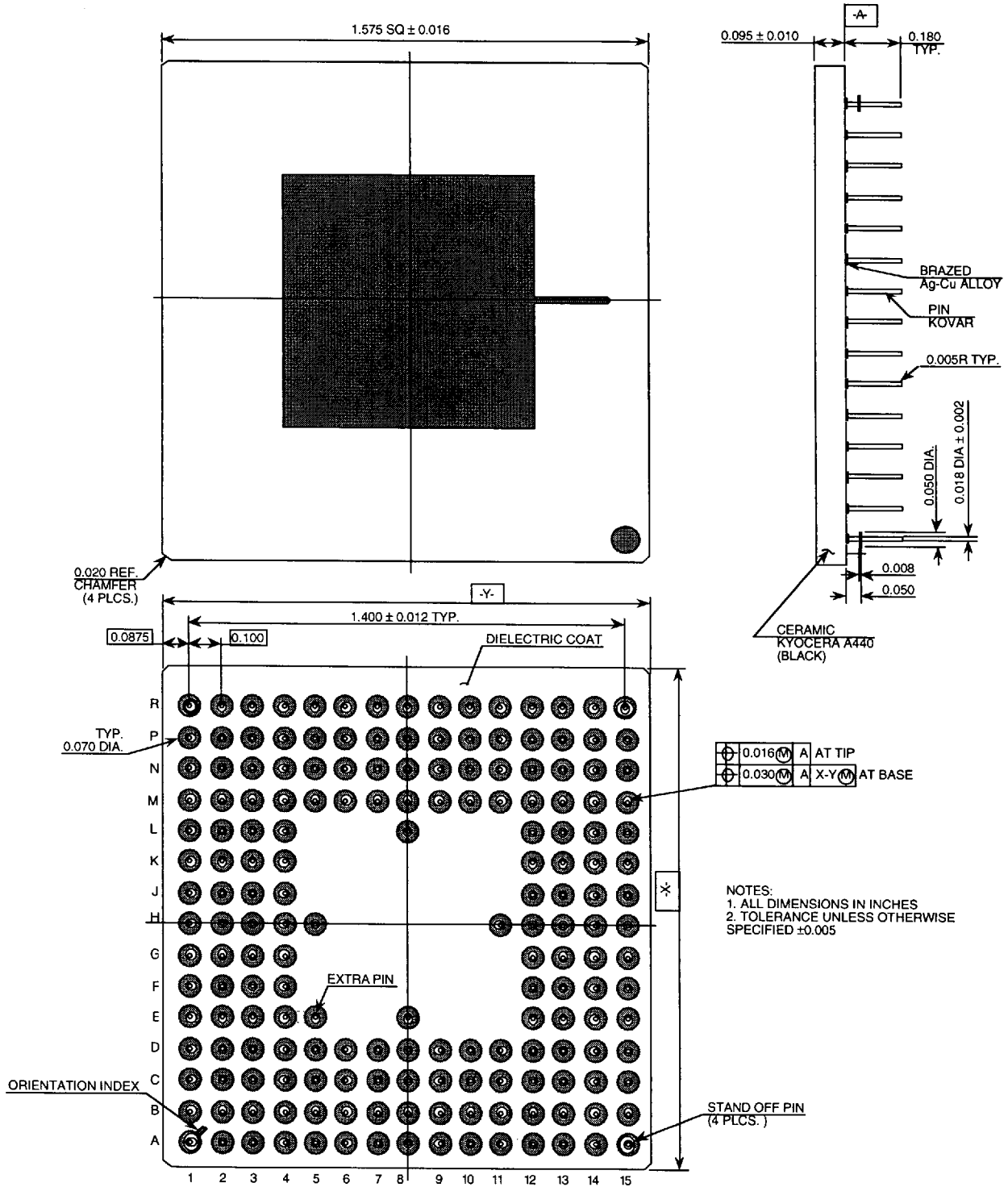

208 Pin Slugged Metric Plastic Quad Flatpack-SMQFP (S SUFFIX):

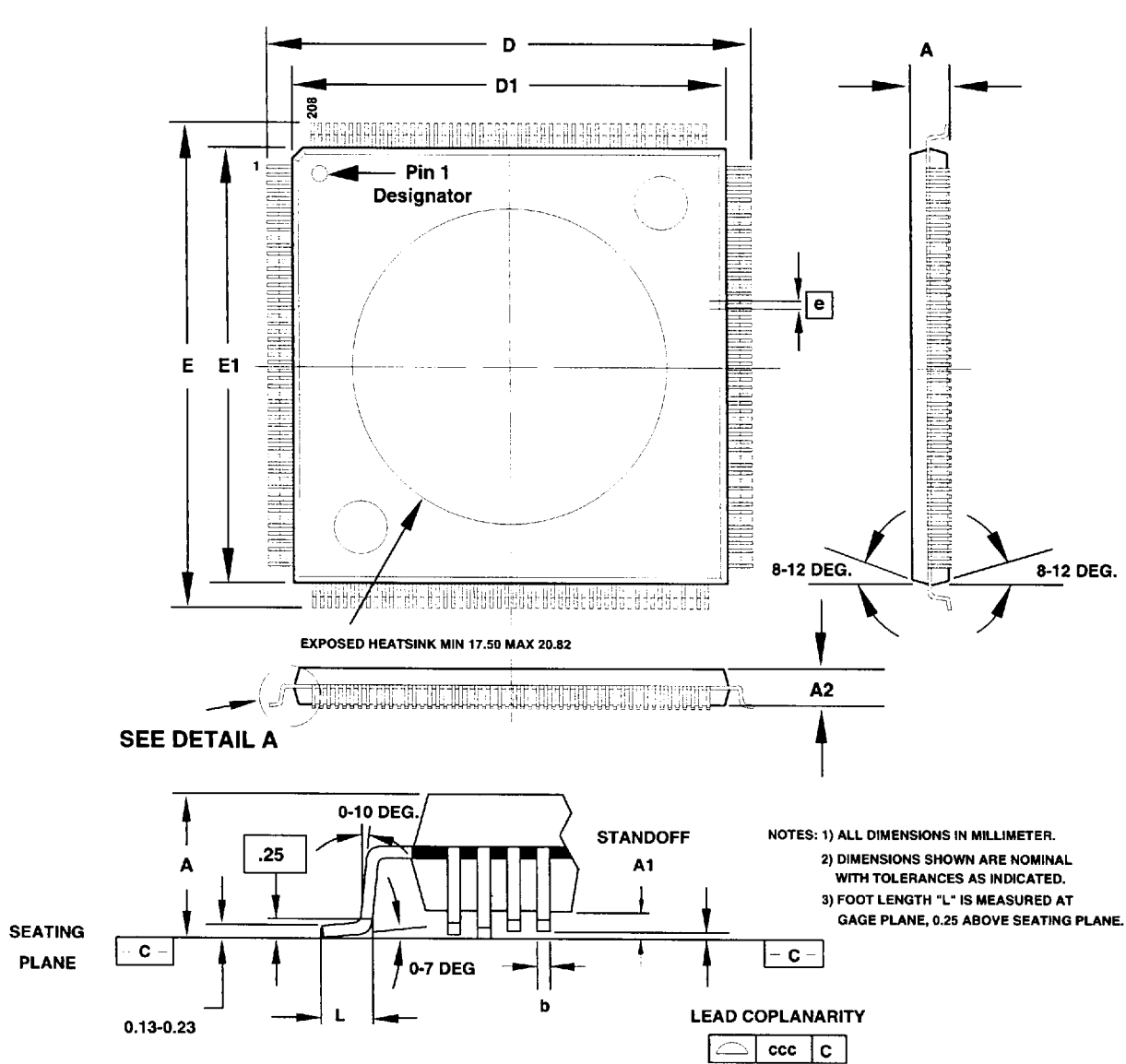

PACKAGE TYPE: 208 PIN SLUGGED METRIC PLASTIC QUAD FLATPACK-SMQFP

BODY SIZE: 28 x 28 x 3.49 MM

Dim.	A	A1	A2	D	D1	E	E1	L	e	b	ccc
Min.	3.45	0.25	3.20	30.35	27.80	30.35	27.80	0.50		0.17	
Nom.	3.75	0.35	3.40	30.60	28.00	30.60	28.00	0.60	0.50	0.22	
Max.	4.10	0.43	3.67	30.85	28.20	30.85	28.20	0.75		0.27	0.10

NOTES

Seller will have no obligation or liability in respect of defects or damage caused by unauthorized use, mis-use, accident, external cause, installation error, or normal wear and tear. There are no warranties, representations or guarantees of any kind, either express or implied by law or custom, regarding the product or its performance, including those regarding quality, merchantability, fitness for purpose, condition, design, title, infringement of third-party rights, or conformance with sample. Seller shall not be responsible for any loss or damage of whatever nature resulting from the use of, or reliance upon, the information contained in this document. In no event will Seller be liable to Buyer or to any other party for loss of profits, loss of savings, or punitive, exemplary, incidental, consequential or special damages, even if Seller has knowledge of the possibility of such potential loss or damage and even if caused by Seller's negligence.

© 1995 PMC-Sierra, Inc.

930829R4 ref 920813R7

Issue date: April, 1995.

Printed in Canada