

37–40 GHz GaAs MMIC Low Noise Amplifier



AA038N3-00

Features

- Single Bias Supply Operation (5 V)
- 3.5 dB Typical Noise Figure at 38 GHz
- 13 dB Typical Small Signal Gain
- 0.25 μm Ti/Pd/Au Gates
- 100% On-Wafer RF, DC and Noise Figure Testing
- 100% Visual Inspection to MIL-STD-883 MT 2010

Description

Skyworks' three-stage reactively-matched 37–40 GHz MMIC low noise amplifier has typical small signal gain of 13 dB with a typical noise figure of 3.5 dB at 38 GHz. The chip uses Skyworks' proven 0.25 μm low noise PHEMT technology, and is based upon MBE layers and electron beam lithography for the highest uniformity and repeatability. The FETs employ surface passivation to ensure a rugged reliable part with through-substrate via holes and gold-based backside metallization to facilitate a conductive epoxy die attach process.

Chip Outline

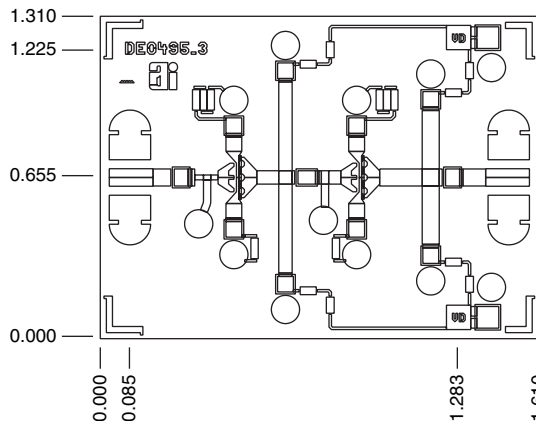

Dimensions indicated in mm.
All DC (V) pads are 0.1 x 0.1 mm and RF In, Out pads are 0.07 mm wide.
Chip thickness = 0.1 mm.

Absolute Maximum Ratings

Characteristic	Value
Operating Temperature (T_C)	-55°C to +90°C
Storage Temperature (T_{ST})	-65°C to +150°C
Bias Voltage (V_D)	6 V_{DC}
Power In (P_{IN})	10 dBm
Junction Temperature (T_J)	175°C

Electrical Specifications at 25°C ($V_{DS} = 5 V$)

Parameter	Condition	Symbol	Min.	Typ. ³	Max.	Unit
Drain Current	$V_D = 5 V$	I_{DS}		20	27	mA
Small Signal Gain	$F = 37\text{--}40 \text{ GHz}$	G	10	13		dB
Noise Figure	$F = 38 \text{ GHz}$	NF		3.5	3.8	dB
Input Return Loss	$F = 37\text{--}40 \text{ GHz}$	RL_I		-12	-6	dB
Output Return Loss	$F = 37\text{--}40 \text{ GHz}$	RL_O		-12	-6	dB
Output Power at 1 dB Gain Compression ¹	$F = 38 \text{ GHz}$	$P_{1 \text{ dB}}$		6		dBm
Two-Tone Output Third-Order Intercept ¹	$F = 38 \text{ GHz}$	OIP3		15		dBm
Thermal Resistance ²		θ_{JC}		202		°C/W

1. Not measured on a 100% basis.

2. Calculated value based on measurement of discrete FET.

3. Typical represents the median parameter value across the specified frequency range for the median chip.

Typical Performance Data

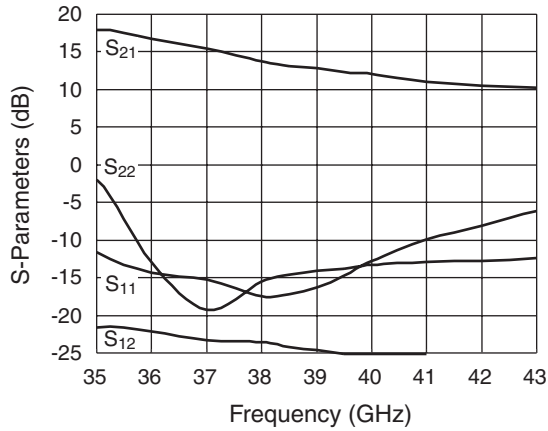

Typical Small Signal Performance S-Parameters ($V_{DS} = 5\text{ V}$)

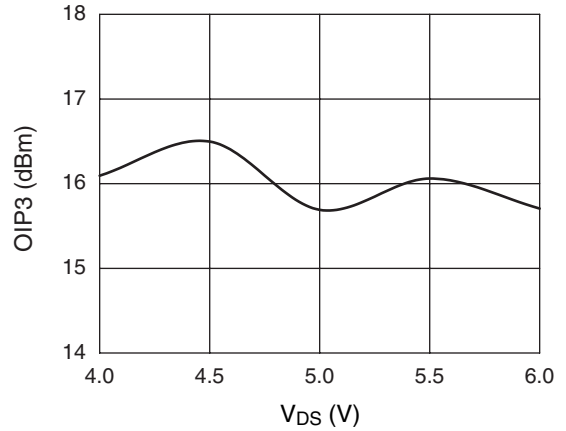

Two-Tone Output Third-Order Intercept @ 38 GHz

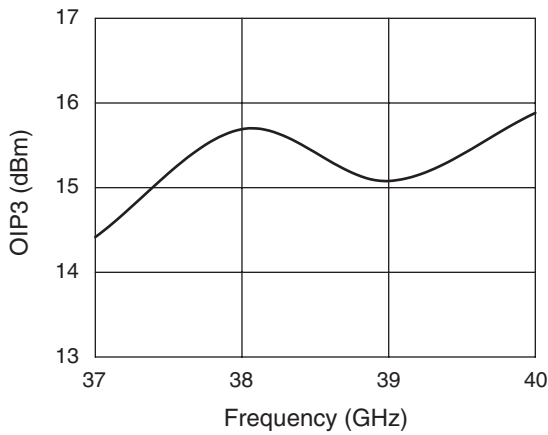

Two-Tone Output Third-Order Intercept @ $V_{DS} = 5\text{ V}$

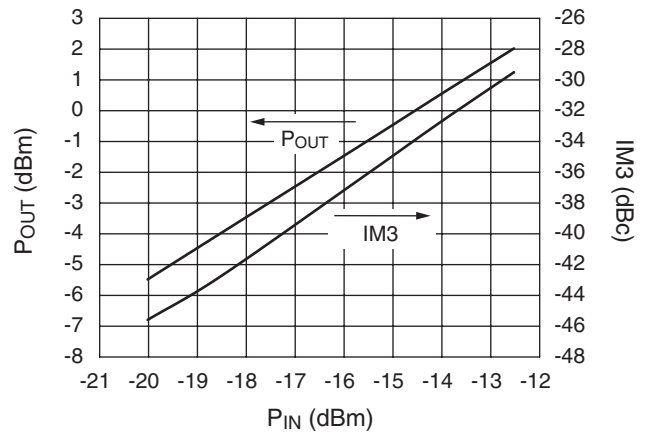

Output Power and Relative Third-Order Intermodulation Products $F = 38\text{ GHz}, V_{DS} = 5\text{ V}$

Bias Arrangement

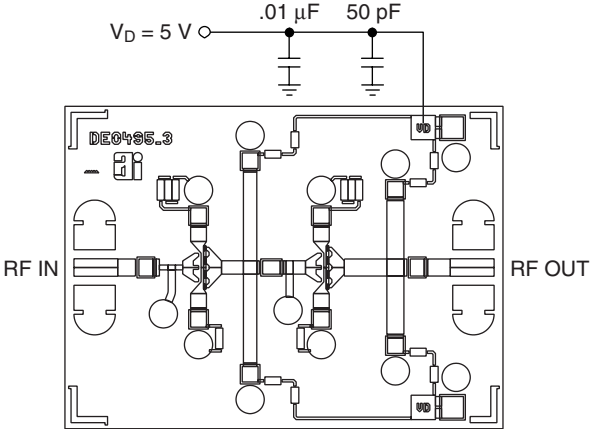

For biasing on, adjust V_{DS} from zero to the desired value (5 V recommended). For biasing off, reverse the biasing on procedure.

Circuit Schematic

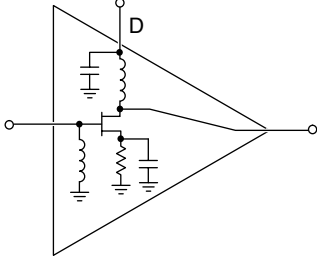

Detail A

