

16-Channel, 12-Bit Data Acquisition System

FEATURES

- Multiplexer, instrumentation amp, S/H, A/D and control logic in a 62-pin package
- Three state output buffer
- Instrumentation amp with selectable gain ranging 1 to 1,000
- Single-ended (-16) and differential (-8) inputs
- 50 kHz minimum throughput

DESCRIPTION

The HS9403-8 and 9403-16 provide complete 12-bit data acquisition functionality in a single, 62-pin package. The 9403 includes 8- or 16-channel multiplexing, a programmable gain instrumentation amplifier, sample-hold circuit, 10V buffered reference, 12-bit 10-sec A/D and three-state output buffers.

The 9403 is flexible enough to accept full-scale input ranges from ± 10 mV to ± 10 V. Three-state output buffers allow output data to be accessed in any combination of three 4-bit bytes. Expansion to 32 single-ended or 16 differential inputs can be achieved with the addition of only 2 ICs.

The 9403 is packaged in a 62-pin, hermetically sealed ceramic package. Temperature ranges available are 0°C to 70°C for commercial versions and -55°C to +125°C with MIL-STD-883C screening for military grades.

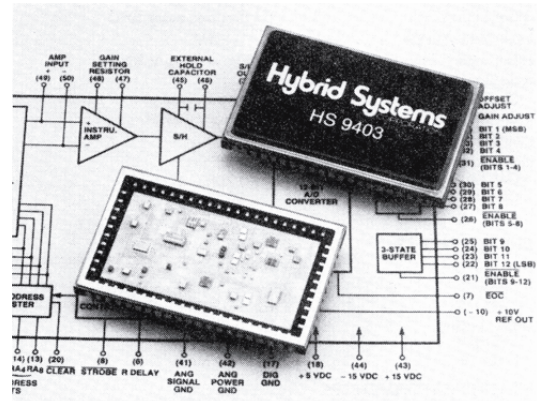

FUNCTIONAL DIAGRAM

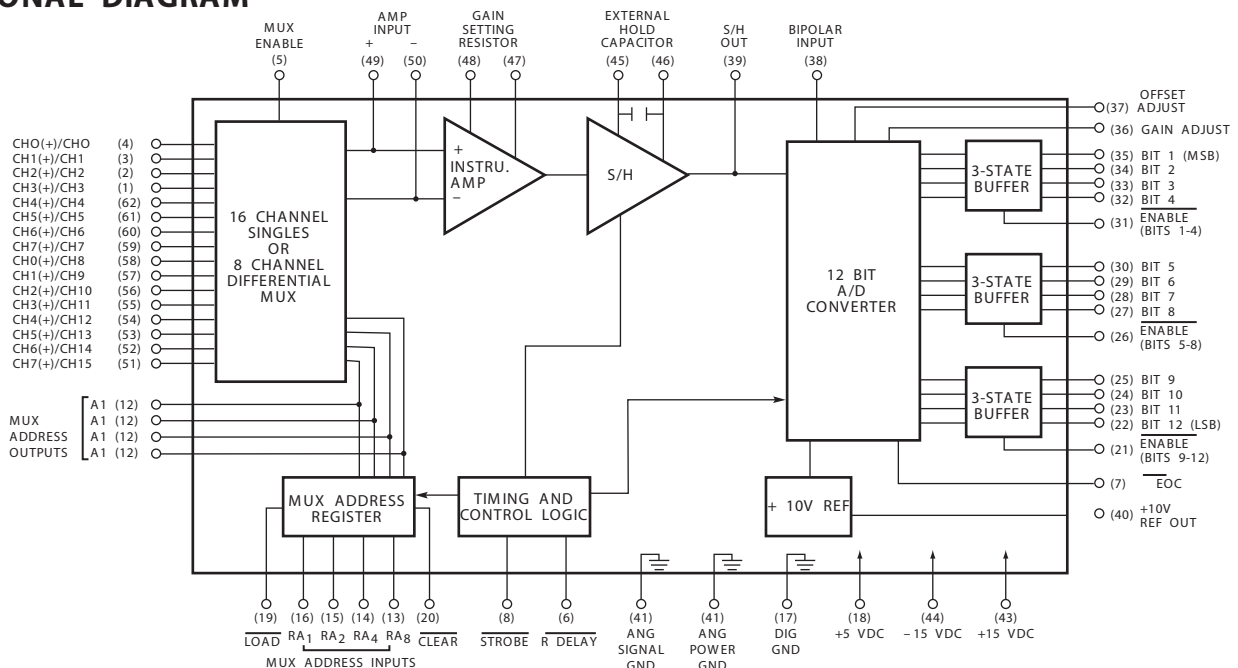

HS9403

SPECIFICATIONS

(Typical @ + 25°C and nominal power supplies unless otherwise specified)

ANALOG INPUTS		HS 9403
Number of Input Channels		
HS 9403-8	8 Differential	
HS 9403-16	16 Single-Ended	
Input Voltage Range ¹		
Unipolar	0 to +10V	
Bipolar	±10V	
Common Mode Voltage Range		
± 11V min		
CMRR		
G=1 (1 kHz)	74 dB	
G=1000 (60 Hz)	110 dB	
Input Bias Current		
±50 pA typ		
Bias Current Drift		
Doubles every 10°C		
Input Offset Current		
±25 pA typ.		
Offset Current Drift		
Doubles every 10°C		
Input Offset Voltage		
±2 mV		
Offset Voltage Drift		
(20 + 7G)µ V/°C		
Voltage Noise (RTI) ²		
G=1	150 µ V(RMS) ³	
G=1000	1.6 µ V(RMS) ³	
Input Resistance		
10 ¹²		
Input Capacitance		
OFF Channel	10 pF	
ON Channel 9403-8	50 pF	
9403-16	100 pF	

DIGITAL INPUTS

Logic Levels	
Logic "1"	+2V min,+5.5V max
Logic "0"	-0.3Vmin,+0.8V max
Logic Loading	
Logic "1"	20 µA
Logic "0"	-0.2 mA

STATIC PERFORMANCE⁴

No Missing Codes	Guaranteed over operating temperature range
Integral Linearity Error	±1/4LSB typ. ±1/2LSB max
Differential Linearity Error	±1/4LSB typ. ±1/2LSB max
Unipolar Offset Errors	±0.025% FSR typ.
	±0.1% FSR ⁶ max
Bipolar Zero Error ⁵	±0.025% FSR typ.
	±0.1% FSR ⁶ max
Gain Error ⁵	±0.025% typ. ±0.2% max

+ 10V REFERENCE

Output Voltage	+ 10.000V ± 10 mV
Output Voltage Drift	± 3 ppm/°C typ, ± 8 ppm/°C max

DYNAMIC PERFORMANCE

Throughput Rate	50KHz min
S/H Acquisition Time ^{7,11}	9µsec typ. 10µsec max.
A/D Conversion Time	10µsec max.
Aperture Delay	25 nsec typ.
Sample-Hold Droop	0.1µV/µsec
Feedthrough (@ 1 kHz) ^{8,11}	±0.01% max.
MUX Crosstalk (@1 kHz) ¹¹	-80dB min.
Strobe Command Pulse Width ¹¹	40 nsec min.
Setup time Digital Inputs to Strobe ¹¹	50 nsec min.
Hold Time Digital Inputs From Strobe ¹¹	150 nsec max.
ENABLE	
Tri-State to Valid ¹¹	40 nsec max.
Valid to Teh-State ¹¹	30 nsec max.

DRIFT CHARACTERISTICS¹⁰

Integral Linearity	±1ppm/°C typ, ±2 ppm/°C max
Differential Linearity	±1ppm/°C typ, ±2 ppm/°C max
Unipolar Offset	±3ppm/°C typ, ±7 ppm/°C max
Bipolar Zero	±3ppm/°C typ, ±10 ppm/°C max
Gain	±8ppm/°C typ, ±20ppm/°C max

DIGITAL OUTPUTS

Logic Levels	
Logic "1"	2.4V min
Logic "0"	0.4V max
Logic Coding	
Unipolar Ranges	Straight binary
Bipolar Ranges	Offset binary
Fanout	
5 TTL Loads	

POWER SUPPLIES

Power Supply Range	
±15V	± 14.5V to ± 15.5V
+5V	+ 4.5V to +5.5V
Current Drains	
+15V	55 mA typ. 60 mA max
-15V	60 mA typ, 68 mA max
+5V	32 mA typ, 45 mA max
Power Dissipation	
1.4W typ.2.0W max	
P.S.R.R. for 3 supplies	
0.005% /% max	
P.S.R.R.(+10Vref)	
0.01 % /% max	

TEMPERATURE RANGE

Operating C-Option	0°Cto +70°C
Operating B-Option	-55°Cto +125°C
Storage	-65°Cto +150°C

ABSOLUTE MAXIMUM RATINGS

+V _{CC}	-0.5V to +18V
-V _{CC}	+ 0.5V to -18V
V _{DD}	-0.3 to +7V
Analog Input Channels	±35V
Digital Inputs	-0.3toV _{DD} +0.3V

Notes:

- For unity gain.
- Referred to input.
- Measured at output of S/H.
- Specifications refer to entire system from MUX input to A/D output with instrumentation amplifier G= 1.
- Initial offset and gain errors are adjustable to zero with optional external
- FSR s full scale range. Unipolar FSR = 10V. Bipolar FSR = 20V. For a 12-bit system.1 LSB = 0.024% FSR
- Includes MUX switching and setting time. instrumentation amp unity gain settling time and S/H acquisition time. Specified for 10V step setting to 0.01 % FSR
- Measured at S/H output with S/H in hold mode.
- Includes MUX address. MUX enable, dear and load inputs.
- Unipolar 10V FSR is the basis for parts per million specifications.
- Guaranteed but not tested.

PACKAGE OUTLINE

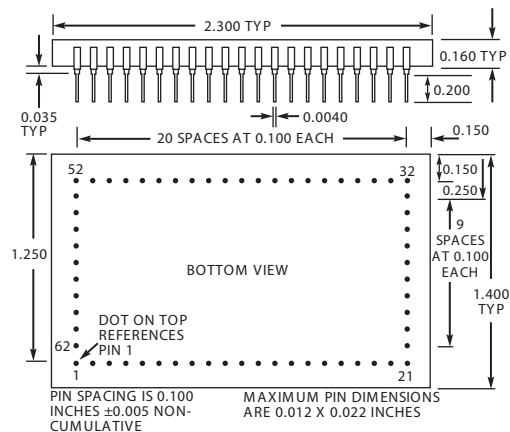

Continued on next page.

PIN ASSIGNMENTS

PIN NO.	FUNCTION HS 9403-16	FUNCTION HS 9403-8
1	CH3 IN	CH3(+)-IN
2	CH2 IN	CH2(+)-IN
3	CH1 IN	CH1(+)-IN
4	CH0 IN	CH0(+)-IN
5	MUX ENABLE	
6	R DELAY	
7	EOC	
8	STROBE	
9	A8	
10	A4 MUX ADDRESS OUT	
11	A2	
12	A1	
13	RA8	
14	RA4 MUX ADDRESS IN	
15	RA2	
16	RA1	
17	DIGITAL GROUND	
18	+5V	
19	LOAD ENABLE	
20	CLEAR ENABLE	
21	ENABLE (BITS 9-12)	
22	BIT12 OUT(LSB)	
23	BIT 11 OUT	
24	BIT 10 OUT	
25	BIT 9 OUT	
26	ENABLE (BITS 5.8)	
27	BIT 8 OUT	
28	BIT 7 OUT	
29	BIT 6 OUT	
30	BIT 5 OUT	
31	ENABLE (BITS 1-4)	
32	BIT 4 OUT	
33	BIT 3 OUT	
34	BIT 2 OUT	
35	BIT 1 OUT (MSB)	
36	GAIN ADJ	
37	OFFSET ADJ	
38	BIPOLAR INPUT	
39	SAMPLE/HOLD OUT	
40	+ 10V REFERENCE OUT	
41	ANALOG SIGNAL GROUND	
42	ANALOG POWER GROUND	
43	+15V	
44	-15V	
45	EXTERNAL HOLD CAP HIGH	
46	EXTERNAL HOLD CAP LOW	
47	R GAIN LOW	
48	R GAIN HIGH	
49	INSTRU. AMP (+) INPUT	
50	INSTRU. AMP (-) INPUT	
51	CH151N	CH7(-)-IN
52	CH14 IN	CH6(-)-IN
53	CH13IN	CH5(-)-IN
54	CH121N	CH4(-)-IN
55	CH11IN	CH3(-)-IN
56	CH10IN	CH2(-)-IN
57	CH9 IN	CH1(-)-IN
58	CH8 IN	CH0(-)-IN
59	CH7 IN	CH7(+)-IN
60	CH6 IN	CH6(+)-IN
61	CH5 IN	CH5(+)-IN
62	CH4 IN	CH4(+)-IN

DIGITAL PIN FUNCTIONS

FUNCTION	PIN NO	LOGIC STATE	DESCRIPTION
MUX ENABLE	5	"0" "1"	Disables internal MUX Enables internal MUX
EOC	7	"0" "1"	Signal acquisition cycle in progress A/D conversion in progress
STROBE	8	"0" to "1" "1" to "0"	Conversion complete Initiates acquisition and conversion of analog signal
MUX ADDRESS OUT	9-12		Output of MUX address register. Straight binary coding
MUX ADDRESS IN	13-16		Selects MUX for random address mode. Straight binary coding
LOAD	19	"0"	Random address mode initiated on falling edge of STROBE
CLEAR	20	"1" "0"	Sequential address mode Forces MUX address to CH0 on next falling edge of STROBE regardless of LOAD and MUX address inputs
ENABLE (BITS 9-12)	21	"0" "1"	Enables three-state outputs bits 9-12 Disables three-state outputs bits 9-12
ENABLE (BITS 5-8)	26	"0" "1"	Enables three-state outputs bits 5-8 Disables three-state outputs bits 5-8
ENABLE (BITS 1-4)	31	"0" "1"	Enables three-state outputs bits 1-4 Disables three-state outputs bits 1-4

ANALOG PIN FUNCTIONS

FUNCTION	PIN NO.	DESCRIPTION
R DELAY	6	Connect external resistor to lengthen S/H acquisition time when instrumentation AMP is set for high gain (for normal operation, R DELAY tied to +5V).
GAIN ADJUST	36	External gain adjust (optional)
OFFSET ADJUST	37	External offset adjust(optional)
BIPOLAR INPUT	38	For unipolar operation (0 to + 10V). connect to pin 39 (S/H OUT). For Bipolar operation ($\pm 10V$). connect to pin 40 (+10V REF OUT)
S/H OUTPUT	39	Sample-Hold output
+10VREFOUT	40	Buffered + 10V reference output
EXTERNAL HOLD CAPACITOR	45.46	Add external polypropylene, polystyrene or teflon hold capacitor to improve S/H droop rate (optional)
RGAIN	47.48	Optional gain selection point. $R = 20k/(G-1)$. Leave open for $G=1$
INSTRUMENTATION AMP INPUTS	49.50	Use when adding additional external multiplexers for expanded single-ended or differential operation (see Applications Information). Connect pin 50 to analog common for HS 9403-16

ORDERING INFORMATION

MODEL NUMBER	TEMPERATURE RANGE	DESCRIPTION
HS 9403C-8	0°C to +70°C	8 differential input, 12-bit. data acquisition system (DAS)
HS9403C-16	0°C to +70°C	16 single-ended input, 12-bit, DAS
HS 9403B-8	-55°C to +125°C	8 differential input, 12-bit, DAS MIL-STD-883C
HS9403B-16	-55°C to +125°C	16 single-ended input, 12-bit, DAS MIL-STD-883C
HS9403C-16 FP	0°C to +70°C	16 single-ended input in flat pack
HS9403B-16 FP	-55°C to +125°C	16 single-ended input, in flat pack. MIL-STD-883C

Specifications subject to change without notice.

Consult factory for application information.