

MH8S64QFC -7,-7L,-8,-8L,-10,-10L

536870912-BIT (8388608 - WORD BY 64-BIT) Synchronous DRAM

DESCRIPTION

The MH8S64QFC is 8388608 - word by 64-bit Synchronous DRAM module. This consists of four industry standard 8Mx16 Synchronous DRAMs in TSOP and one industry standard EEPROM in TSSOP.

The mounting of TSOP on a card edge Dual Inline package provides any application where high densities and large quantities of memory are required.

This is a socket type - memory modules, suitable for easy interchange or addition of modules.

- Utilizes industry standard 8M x 16 Synchronous DRAMs TSOP and industry standard EEPROM in TSSOP
- 144-pin (72-pin dual in-line package)
- single 3.3V±0.3V power supply
- Clock frequency 100MHz(max.)
- Fully synchronous operation referenced to clock rising edge
- 4 bank operation controlled by BA0,1(Bank Address)
- /CAS latency- 2/3(programmable)
- Burst length- 1/2/4/8/Full Page(programmable)
- Burst type- sequential / interleave(programmable)
- Column access - random
- Auto precharge / All bank precharge controlled by A10
- Auto refresh and Self refresh
- 4096 refresh cycle /64ms
- LVTTTL Interface

FEATURES

	Frequency	CLK Access Time (Component SDRAM)
-7,-7L	100MHz	6.0ns(CL=3)
-8,-8L	100MHz	6.0ns(CL=3)
-10,-10L	100MHz	8.0ns(CL=3)

PC100 Compliant

APPLICATION

main memory or graphic memory in computer systems

PCB Outline

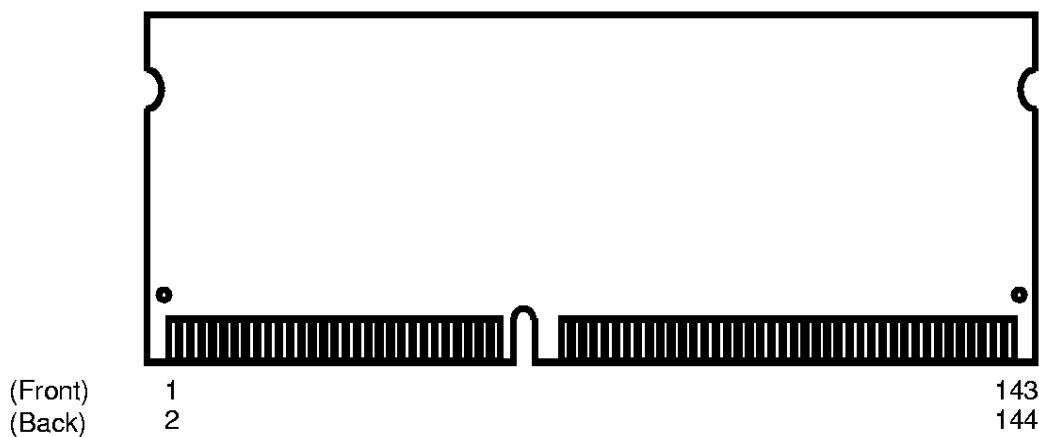

MH8S64QFC -7,-7L,-8,-8L,-10,-10L

536870912-BIT (8388608 - WORD BY 64-BIT)SynchronousDRAM

PIN CONFIGURATION

PIN Number	Front side Pin Name	PIN Number	Back side Pin Name	PIN Number	Front side Pin Name	PIN Number	Back side Pin Name
1	Vss	2	Vss	73	NC	74	CLK1
3	DQ0	4	DQ32	75	Vss	76	Vss
5	DQ1	6	DQ33	77	NC	78	NC
7	DQ2	8	DQ34	79	NC	80	NC
9	DQ3	10	DQ35	81	Vcc	82	Vcc
11	Vcc	12	Vcc	83	DQ16	84	DQ48
13	DQ4	14	DQ36	85	DQ17	86	DQ49
15	DQ5	16	DQ37	87	DQ18	88	DQ50
17	DQ6	18	DQ38	89	DQ19	90	DQ51
19	DQ7	20	DQ39	91	Vss	92	Vss
21	Vss	22	Vss	93	DQ20	94	DQ52
23	DQMB0	24	DQMB4	95	DQ21	96	DQ53
25	DQMB1	26	DQMB5	97	DQ22	98	DQ54
27	Vcc	28	Vcc	99	DQ23	100	DQ55
29	A0	30	A3	101	Vcc	102	Vcc
31	A1	32	A4	103	A6	104	A7
33	A2	34	A5	105	A8	106	BA0
35	Vss	36	Vss	107	Vss	108	Vss
37	DQ8	38	DQ40	109	A9	110	BA1
39	DQ9	40	DQ41	111	A10	112	A11
41	DQ10	42	DQ42	113	Vcc	114	Vcc
43	DQ11	44	DQ43	115	DQMB2	116	DQMB6
45	Vcc	46	Vcc	117	DQMB3	118	DQMB7
47	DQ12	48	DQ44	119	Vss	120	Vss
49	DQ13	50	DQ45	121	DQ24	122	DQ56
51	DQ14	52	DQ46	123	DQ25	124	DQ57
53	DQ15	54	DQ47	125	DQ26	126	DQ58
55	Vss	56	Vss	127	DQ27	128	DQ59
57	NC	58	NC	129	Vcc	130	Vcc
59	NC	60	NC	131	DQ28	132	DQ60
61	CLK0	62	CKE0	133	DQ29	134	DQ61
63	Vcc	64	Vcc	135	DQ30	136	DQ62
65	/RAS	66	/CAS	137	DQ31	138	DQ63
67	/WE	68	NC	139	Vss	140	Vss
69	/S0	70	NC	141	SDA	142	SCL
71	NC	72	NC	143	Vcc	144	Vcc

NC = No Connection

MH8S64QFC -7,-7L,-8,-8L,-10,-10L

536870912-BIT (8388608 - WORD BY 64-BIT) Synchronous DRAM

Block Diagram

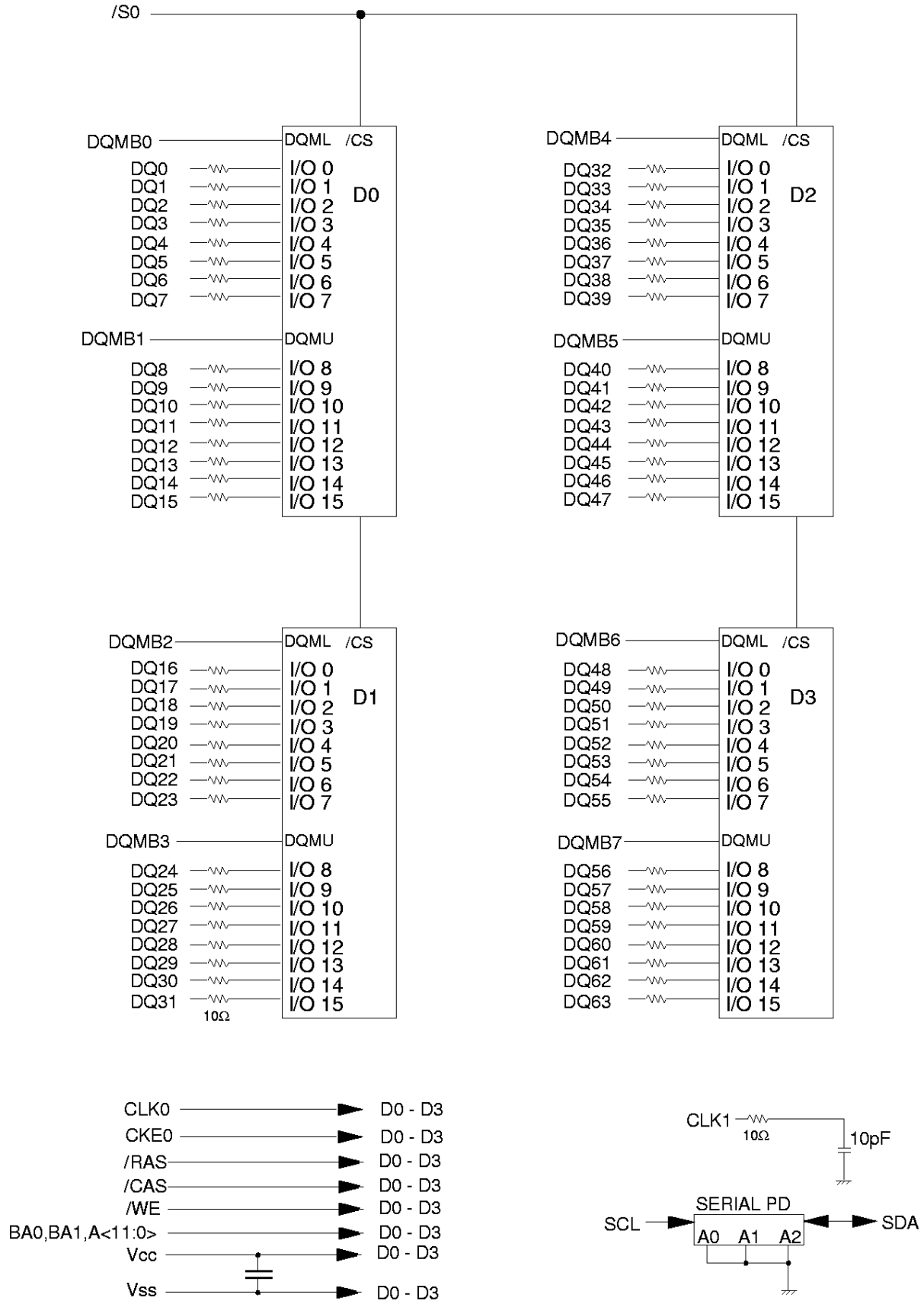

MH8S64QFC -7,-7L,-8,-8L,-10,-10L

536870912-BIT (8388608 - WORD BY 64-BIT)SynchronousDRAM

Serial Presence Detect Table I

Byte	Function described	SPD entry data	SPD DATA(hex)
0	Defines # bytes written into serial memory at module mfg	128	80
1	Total # bytes of SPD memory device	256 Bytes	08
2	Fundamental memory type	SDRAM	04
3	# Row Addresses on this assembly	A0-A11	0C
4	# Column Addresses on this assembly	A0-A8	09
5	# Module Banks on this assembly	1BANK	01
6	Data Width of this assembly...	x64	40
7	... Data Width continuation	0	00
8	Voltage interface standard of this assembly	LVTTL	01
9	SDRAM Cycletime at Max. Supported CAS Latency (CL). Cycle time for CL=3	10ns	A0
10	SDRAM Access from Clock tAC for CL=3	-7,8	60
		-10	80
11	DIMM Configuration type (Non-parity,Parity,ECC)	Non-PARITY	00
12	Refresh Rate/Type	self refresh(15.625uS)	80
13	SDRAM width,Primary DRAM	x16	10
14	Error Checking SDRAM data width	N/A	00
15	Minimum Clock Delay,Back to Back Random Column Addresses	1	01
16	Burst Lengths Supported	1/2/4/8/Full page	8F
17	# Banks on Each SDRAM device	4bank	04
18	CAS# Latency	2/3	06
19	CS# Latency	0	01
20	Write Latency	0	01
21	SDRAM Module Attributes	non-buffered,non-registered	00
22	SDRAM Device Attributes:General	Precharge All,Auto precharge	0E
23	SDRAM Cycle time(2nd highest CAS latency) Cycle time for CL=2	-7	A0
		-8	D0
		-10	F0
24	SDRAM Access form Clock(2nd highest CAS latency) tAC for CL=2	-7	60
		-8	70
		-10	80
25	SDRAM Cycle time(3rd highest CAS latency)	N/A	00
26	SDRAM Access form Clock(3rd highest CAS latency)	N/A	00
27	Precharge to Active Minimum	-7,8	14
		-10	1E
28	Row Active to Row Active Min.	20ns	14
29	RAS to CAS Delay Min	-7,8	14
		-10	1E
30	Active to Precharge Min	-7,8	32
		-10	3C

MH8S64QFC -7,-7L,-8,-8L,-10,-10L

536870912-BIT (8388608 - WORD BY 64-BIT)SynchronousDRAM

Serial Presence Detect Table II

31	Density of each bank on module		64MByte	10
32	Command and Address signal input setup time	-7,8	2ns	20
		-10	N/A	00
33	Command and Address signal input hold time	-7,8	1ns	10
		-10	N/A	00
34	Data signal input setup time	-7,8	2ns	20
		-10	N/A	00
35	Data signal input hold time	-7,8	1ns	10
		-10	N/A	00
36-61	Superset Information (may be used in future)		option	00
62	SPD Revision	-7,8	rev 1.2A	12
		-10	rev 1	01
63	Checksum for bytes 0-62		Check sum for -7	0D
			Check sum for -8	4D
			Check sum for -10	4A
64-71	Manufactures Jedec ID code per JEP-108E		MITSUBISHI	1CFFFFFFFFFFFFFF
72	Manufacturing location		Miyoshi,Japan	01
			Tajima,Japan	02
			NC,USA	03
			Germany	04
73-90	Manufactures Part Number		MH8S64QFC-7	4D48385336345146432D37202020202020
			MH8S64QFC-7L	4D48385336345146432D374C2020202020
			MH8S64QFC-8	4D48385336345146432D38202020202020
			MH8S64QFC-8L	4D48385336345146432D384C2020202020
			MH8S64QFC-10	4D48385336345146432D31302020202020
			MH8S64QFC-10L	4D48385336345146432D31304C20202020
91-92	Revision Code		PCB revision	rrrr
93-94	Manufacturing date		year/week code	yyww
95-98	Assembly Serial Number		serial number	ssssssss
99-125	Manufacture Specific Data		option	00
126	Intel specification frequency	-7,8	100MHz	64
		-10	66MHz	66
127	Intel specification CAS# Latency support	-7	CL=2/3,AP,CK0	8F
		-8	CL=3,AP,CK0	8D
		-10	CL=2/3	06
128+	Unused storage locations		open	00

The -7, -8 indicate also -7L, -8L.

MH8S64QFC -7,-7L,-8,-8L,-10,-10L

536870912-BIT (8388608 - WORD BY 64-BIT) Synchronous DRAM

PIN FUNCTION

CK0	Input	Master Clock: All other inputs are referenced to the rising edge of CK
CKE0	Input	Clock Enable: CKE controls internal clock. When CKE is low, internal clock for the following cycle is ceased. CKE is also used to select auto / self refresh. After self refresh mode is started, CKE E becomes asynchronous input. Self refresh is maintained as long as CKE is low.
/S0	Input	Chip Select: When /S is high, any command means No Operation.
/RAS,/CAS,/WE	Input	Combination of /RAS,/CAS,/WE defines basic commands.
A0-11	Input	A0-11 specify the Row/Column Address in conjunction with BA0,1. The Row Address is specified by A0-11. The Column Address is specified by A0-8. A10 is also used to indicate precharge option. When A10 is high at a read / write command, an auto precharge is performed. When A10 is high at a precharge command, both banks are precharged.
BA0,1	Input	Bank Address: BA0,1 is not simply BA. BA specifies the bank to which a command is applied. BA0,1 must be set with ACT, PRE, READ, WRITE commands
DQ0-63	Input/Output	Data In and Data out are referenced to the rising edge of CK
DQMB0-7	Input	Din Mask/Output Disable: When DQMB is high in burst write, Din for the current cycle is masked. When DQMB is high in burst read, Dout is disabled at the next but one cycle.
Vdd,Vss	Power Supply	Power Supply for the memory mounted module.
SCL	Input	Serial clock for serial PD
SDA	Output	Serial data for serial PD

BASIC FUNCTIONS

The MH8S64QFC provides basic functions, bank(row) activate, burst read / write, bank(row) precharge, and auto / self refresh.

Each command is defined by control signals of /RAS, /CAS and /WE at CK rising edge. In addition to 3 signals, /S, CKE and A10 are used as chip select, refresh option, and precharge option, respectively.

To know the detailed definition of commands please see the command truth table.

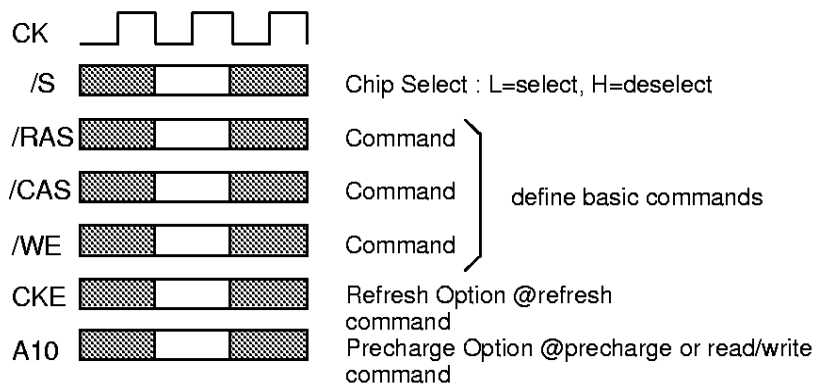

Activate(ACT) [/RAS =L, /CAS = /WE =H]

ACT command activates a row in an idle bank indicated by BA.

Read(READ) [/RAS =H, /CAS =L, /WE =H]

READ command starts burst read from the active bank indicated by BA. First output data appears after /CAS latency. When A10 =H at this command, the bank is deactivated after the burst read(auto-precharge, **READA**).

Write(WRITE) [/RAS =H, /CAS = /WE =L]

WRITE command starts burst write to the active bank indicated by BA. Total data length to be written is set by burst length. When A10 =H at this command, the bank is deactivated after the burst write(auto-precharge, **WRITEA**).

Precharge(PRE) [/RAS =L, /CAS =H, /WE =L]

PRE command deactivates the active bank indicated by BA. This command also terminates burst read / write operation. When A10 =H at this command, both banks are deactivated(precharge all, **PREA**).

Auto-Refresh(REFA) [/RAS =/CAS =L, /WE =CKE =H]

PEFA command starts auto-refresh cycle. Refresh address including bank address are generated internally. After this command, the banks are precharged automatically.

COMMAND TRUTH TABLE

COMMAND	MNEMONIC	CKE _{n-1}	CKE _n	/S	/RAS	/CAS	/WE	BA0,1	A11	A10	A0-9
Deselect	DESEL	H	X	H	X	X	X	X	X	X	X
No Operation	NOP	H	X	L	H	H	H	X	X	X	X
Row Adress Entry & Bank Activate	ACT	H	X	L	L	H	H	V	V	V	V
Single Bank Precharge	PRE	H	X	L	L	H	L	V	X	L	X
Precharge All Bank	PREA	H	X	L	L	H	L	X	X	H	X
Column Address Entry & Write	WRITE	H	X	L	H	L	L	V	X	L	V
Column Address Entry & Write with Auto-Precharge	WRITEA	H	X	L	H	L	L	V	X	H	V
Column Address Entry & Read	READ	H	X	L	H	L	H	V	X	L	V
Column Address Entry & Read with Auto-Precharge	READA	H	X	L	H	L	H	V	X	H	V
Auto-Refresh	REFA	H	H	L	L	L	H	X	X	X	X
Self-Refresh Entry	REFS	H	L	L	L	L	H	X	X	X	X
Self-Refresh Exit	REFSX	L	H	H	X	X	X	X	X	X	X
		L	H	L	H	H	H	X	X	X	X
Burst Terminate	TERM	H	X	L	H	H	L	X	X	X	X
Mode Register Set	MRS	H	X	L	L	L	L	L	L	L	V*1

H =High Level, L = Low Level, V = Valid, X = Don't Care, n = CK cycle number

NOTE:

1.A7-9 = 0, A0-6 = Mode Address

MH8S64QFC -7,-7L,-8,-8L,-10,-10L

536870912-BIT (8388608 - WORD BY 64-BIT)SynchronousDRAM

FUNCTION TRUTH TABLE

Current State	/S	/RAS	/CAS	/WE	Address	Command	Action
IDLE	H	X	X	X	X	DESEL	NOP
	L	H	H	H	X	NOP	NOP
	L	H	H	L	BA	TBST	ILLEGAL*2
	L	H	L	X	BA,CA,A10	READ/WRITE	ILLEGAL*2
	L	L	H	H	BA,RA	ACT	Bank Active,Latch RA
	L	L	H	L	BA,A10	PRE/PREA	NOP*4
	L	L	L	H	X	REFA	Auto-Refresh*5
	L	L	L	L	Op-Code, Mode-Add	MRS	Mode Register Set*5
ROW ACTIVE	H	X	X	X	X	DESEL	NOP
	L	H	H	H	X	NOP	NOP
	L	H	H	L	BA	TBST	NOP
	L	H	L	H	BA,CA,A10	READ/READA	Begin Read,Latch CA, Determine Auto-Precharge
	L	H	L	L	BA,CA,A10	WRITE/ WRITEA	Begin Write,Latch CA, Determine Auto-Precharge
	L	L	H	H	BA,RA	ACT	Bank Active/ILLEGAL*2
	L	L	H	L	BA,A10	PRE/PREA	Precharge/Precharge All
	L	L	L	H	X	REFA	ILLEGAL
READ	H	X	X	X	X	DESEL	NOP(Continue Burst to END)
	L	H	H	H	X	NOP	NOP(Continue Burst to END)
	L	H	H	L	BA	TBST	Terminate Burst
	L	H	L	H	BA,CA,A10	READ/READA	Terminate Burst,Latch CA, Begin New Read,Determine Auto-Precharge*3
	L	H	L	L	BA,CA,A10	WRITE/WRITEA	Terminate Burst,Latch CA, Begin Write,Determine Auto- Precharge*3
	L	L	H	H	BA,RA	ACT	Bank Active/ILLEGAL*2
	L	L	H	L	BA,A10	PRE/PREA	Terminate Burst,Precharge
	L	L	L	H	X	REFA	ILLEGAL
L	L	L	L	Op-Code, Mode-Add	MRS	ILLEGAL	

MH8S64QFC -7,-7L,-8,-8L,-10,-10L

536870912-BIT (8388608 - WORD BY 64-BIT)SynchronousDRAM

FUNCTION TRUTH TABLE(continued)

Current State	/S	/RAS	/CAS	/WE	Address	Command	Action
WRITE	H	X	X	X	X	DESEL	NOP(Continue Burst to END)
	L	H	H	H	X	NOP	NOP(Continue Burst to END)
	L	H	H	L	BA	TBST	Terminate Burst
	L	H	L	H	BA,CA,A10	READ/READA	Terminate Burst,Latch CA, Begin Read,Determine Auto-Precharge*3
	L	H	L	L	BA,CA,A10	WRITE/ WRITEA	Terminate Burst,Latch CA, Begin Write,Determine Auto-Precharge*3
	L	L	H	H	BA,RA	ACT	Bank Active/ILLEGAL*2
	L	L	H	L	BA,A10	PRE/PREA	Terminate Burst,Precharge
	L	L	L	H	X	REFA	ILLEGAL
	L	L	L	L	Op-Code, Mode-Add	MRS	ILLEGAL
READ with AUTO PRECHARGE	H	X	X	X	X	DESEL	NOP(Continue Burst to END)
	L	H	H	H	X	NOP	NOP(Continue Burst to END)
	L	H	H	L	BA	TBST	ILLEGAL
	L	H	L	H	BA,CA,A10	READ/READA	ILLEGAL
	L	H	L	L	BA,CA,A10	WRITE/ WRITEA	ILLEGAL
	L	L	H	H	BA,RA	ACT	Bank Active/ILLEGAL*2
	L	L	H	L	BA,A10	PRE/PREA	ILLEGAL*2
	L	L	L	H	X	REFA	ILLEGAL
	L	L	L	L	Op-Code, Mode-Add	MRS	ILLEGAL
WRITE with AUTO PRECHARGE	H	X	X	X	X	DESEL	NOP(Continue Burst to END)
	L	H	H	H	X	NOP	NOP(Continue Burst to END)
	L	H	H	L	BA	TBST	ILLEGAL
	L	H	L	H	BA,CA,A10	READ/READA	ILLEGAL
	L	H	L	L	BA,CA,A10	WRITE/ WRITEA	ILLEGAL
	L	L	H	H	BA,RA	ACT	Bank Active/ILLEGAL*2
	L	L	H	L	BA,A10	PRE/PREA	ILLEGAL*2
	L	L	L	H	X	REFA	ILLEGAL
	L	L	L	L	Op-Code, Mode-Add	MRS	ILLEGAL

FUNCTION TRUTH TABLE(continued)

Current State	/S	/RAS	/CAS	/WE	Address	Command	Action
PRE - CHARGING	H	X	X	X	X	DESEL	NOP(Idle after tRP)
	L	H	H	H	X	NOP	NOP(Idle after tRP)
	L	H	H	L	BA	TBST	ILLEGAL*2
	L	H	L	X	BA,CA,A10	READ/WRITE	ILLEGAL*2
	L	L	H	H	BA,RA	ACT	ILLEGAL*2
	L	L	H	L	BA,A10	PRE/PREA	NOP*4(Idle after tRP)
	L	L	L	H	X	REFA	ILLEGAL
	L	L	L	L	Op-Code, Mode-Add	MRS	ILLEGAL
ROW ACTIVATING	H	X	X	X	X	DESEL	NOP(Row Active after tRCD)
	L	H	H	H	X	NOP	NOP(Row Active after tRCD)
	L	H	H	L	BA	TBST	ILLEGAL*2
	L	H	L	X	BA,CA,A10	READ/WRITE	ILLEGAL*2
	L	L	H	H	BA,RA	ACT	ILLEGAL*2
	L	L	H	L	BA,A10	PRE/PREA	ILLEGAL*2
	L	L	L	H	X	REFA	ILLEGAL
	L	L	L	L	Op-Code, Mode-Add	MRS	ILLEGAL
WRITE RE- COVERING	H	X	X	X	X	DESEL	NOP
	L	H	H	H	X	NOP	NOP
	L	H	H	L	BA	TBST	ILLEGAL*2
	L	H	L	X	BA,CA,A10	READ/WRITE	ILLEGAL*2
	L	L	H	H	BA,RA	ACT	ILLEGAL*2
	L	L	H	L	BA,A10	PRE/PREA	ILLEGAL*2
	L	L	L	H	X	REFA	ILLEGAL
	L	L	L	L	Op-Code, Mode-Add	MRS	ILLEGAL

MH8S64QFC -7,-7L,-8,-8L,-10,-10L

536870912-BIT (8388608 - WORD BY 64-BIT) Synchronous DRAM

FUNCTION TRUTH TABLE(continued)

Current State	/S	/RAS	/CAS	/WE	Address	Command	Action
RE-FRESHING	H	X	X	X	X	DESEL	NOP(Idle after tRC)
	L	H	H	H	X	NOP	NOP(Idle after tRC)
	L	H	H	L	BA	TBST	ILLEGAL
	L	H	L	X	BA,CA,A10	READ/WRITE	ILLEGAL
	L	L	H	H	BA,RA	ACT	ILLEGAL
	L	L	H	L	BA,A10	PRE/PREA	ILLEGAL
	L	L	L	H	X	REFA	ILLEGAL
	L	L	L	L	Op-Code, Mode-Add	MRS	ILLEGAL
MODE REGISTER SETTING	H	X	X	X	X	DESEL	NOP(Idle after tRSC)
	L	H	H	H	X	NOP	NOP(Idle after tRSC)
	L	H	H	L	BA	TBST	ILLEGAL
	L	H	L	X	BA,CA,A10	READ/WRITE	ILLEGAL
	L	L	H	H	BA,RA	ACT	ILLEGAL
	L	L	H	L	BA,A10	PRE/PREA	ILLEGAL
	L	L	L	H	X	REFA	ILLEGAL
	L	L	L	L	Op-Code, Mode-Add	MRS	ILLEGAL

ABBREVIATIONS:

H = High Level, L = Low Level, X = Don't Care

BA = Bank Address, RA = Row Address, CA = Column Address, NOP = No Operation

NOTES:

1. All entries assume that CKE was High during the preceding clock cycle and the current clock cycle.
2. ILLEGAL to bank in specified state; function may be legal in the bank indicated by BA, depending on the state of that bank.
3. Must satisfy bus contention, bus turn around, write recovery requirements.
4. NOP to bank precharging or in idle state. May precharge bank indicated by BA.
5. ILLEGAL if any bank is not idle.

ILLEGAL = Device operation and / or data-integrity are not guaranteed.

FUNCTION TRUTH TABLE FOR CKE

Current State	CK _{n-1}	CK _n	/S	/RAS	/CAS	/WE	Add	Action
SELF - REFRESH*1	H	X	X	X	X	X	X	INVALID
	L	H	H	X	X	X	X	Exit Self-Refresh (Idle after tRC)
	L	H	L	H	H	H	X	Exit Self-Refresh (Idle after tRC)
	L	H	L	H	H	L	X	ILLEGAL
	L	H	L	H	L	X	X	ILLEGAL
	L	H	L	L	X	X	X	ILLEGAL
	L	L	X	X	X	X	X	NOP (Maintain Self-Refresh)
POWER DOWN	H	X	X	X	X	X	X	INVALID
	L	H	X	X	X	X	X	Exit Power Down to Idle
	L	L	X	X	X	X	X	NOP (Maintain Self-Refresh)
ALL BANKS IDLE*2	H	H	X	X	X	X	X	Refer to Function Truth Table
	H	L	L	L	L	H	X	Enter Self-Refresh
	H	L	H	X	X	X	X	Enter Power Down
	H	L	L	H	H	H	X	Enter Power Down
	H	L	L	H	H	L	X	ILLEGAL
	H	L	L	H	L	X	X	ILLEGAL
	H	L	L	L	X	X	X	ILLEGAL
	L	X	X	X	X	X	X	Refer to Current State = Power Down
ANY STATE other than listed above	H	H	X	X	X	X	X	Refer to Function Truth Table
	H	L	X	X	X	X	X	Begin CK0 Suspend at Next Cycle*3
	L	H	X	X	X	X	X	Exit CK0 Suspend at Next Cycle*3
	L	L	X	X	X	X	X	Maintain CK0 Suspend

ABBREVIATIONS:

H = High Level, L = Low Level, X = Don't Care

NOTES:

1. CKE Low to High transition will re-enable CK and other inputs **asynchronously**. A minimum setup time must be satisfied before any command other than EXIT.
2. Power-Down and Self-Refresh can be entered only from the All banks idle State.
3. Must be legal command.

SIMPLIFIED STATE DIAGRAM

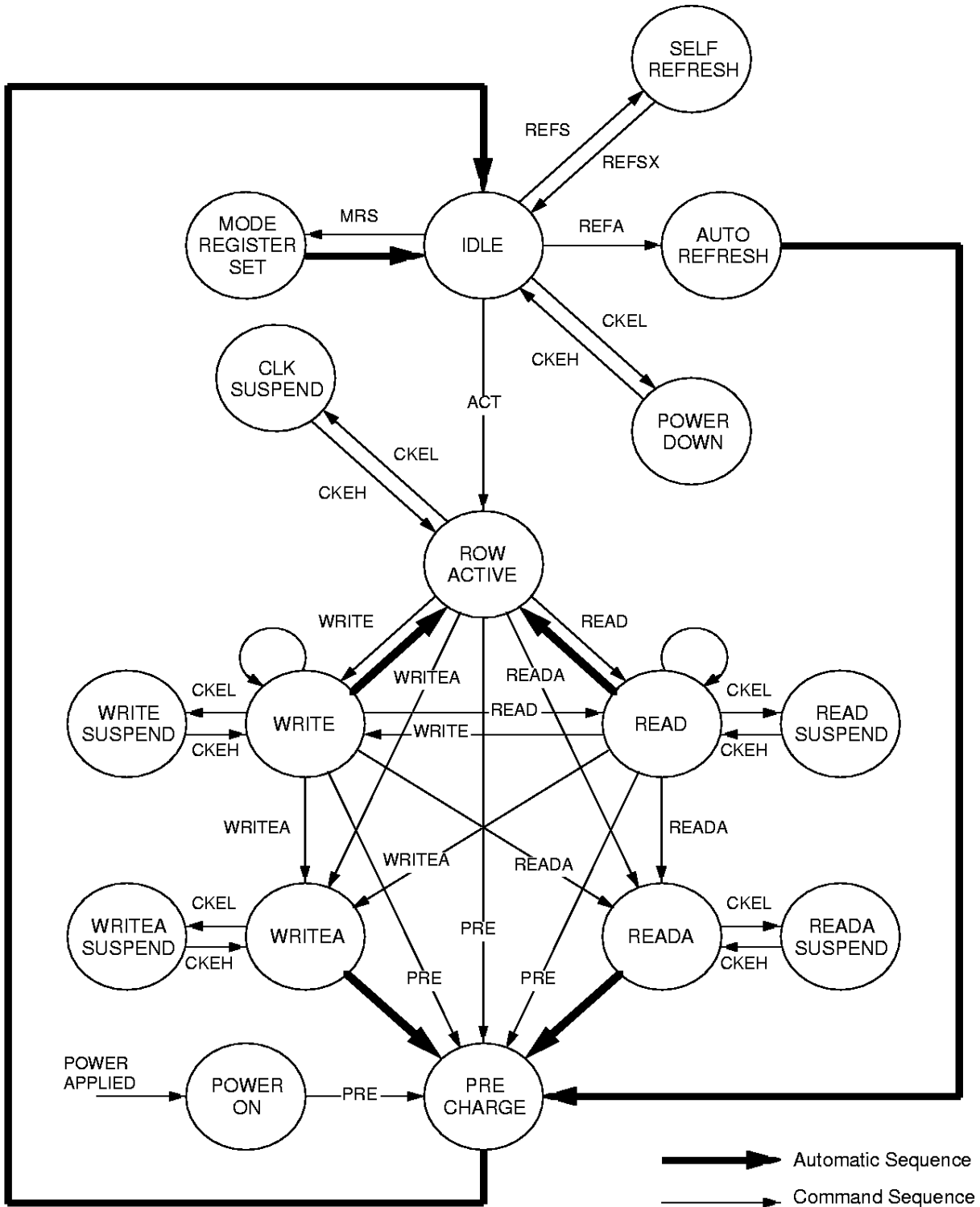

MH8S64QFC -7,-7L,-8,-8L,-10,-10L

536870912-BIT (8388608 - WORD BY 64-BIT) Synchronous DRAM

POWER ON SEQUENCE

Before starting normal operation, the following power on sequence is necessary to prevent a SDRAM from damaged or malfunctioning.

1. Clock will be applied at power up along with power. Attempt to maintain CKE high, DQM0-7 high and NOP condition at the inputs along with power.
2. Maintain stable power, stable clock, and NOP input conditions for a minimum of 200us.
3. Issue precharge commands for all banks. (PRE or PREA)
4. After all banks become idle state (after tRP), issue 8 or more auto-refresh commands.
5. Issue a mode register set command to initialize the mode register.

After these sequence, the SDRAM is idle state and ready for normal operation.

MODE REGISTER

Burst Length, Burst Type and /CAS Latency can be programmed by setting the mode register(MRS). The mode register stores these data until the next MRS command, which may be issued when both banks are in idle state. After tRSC from a MRS command, the SDRAM is ready for new command.

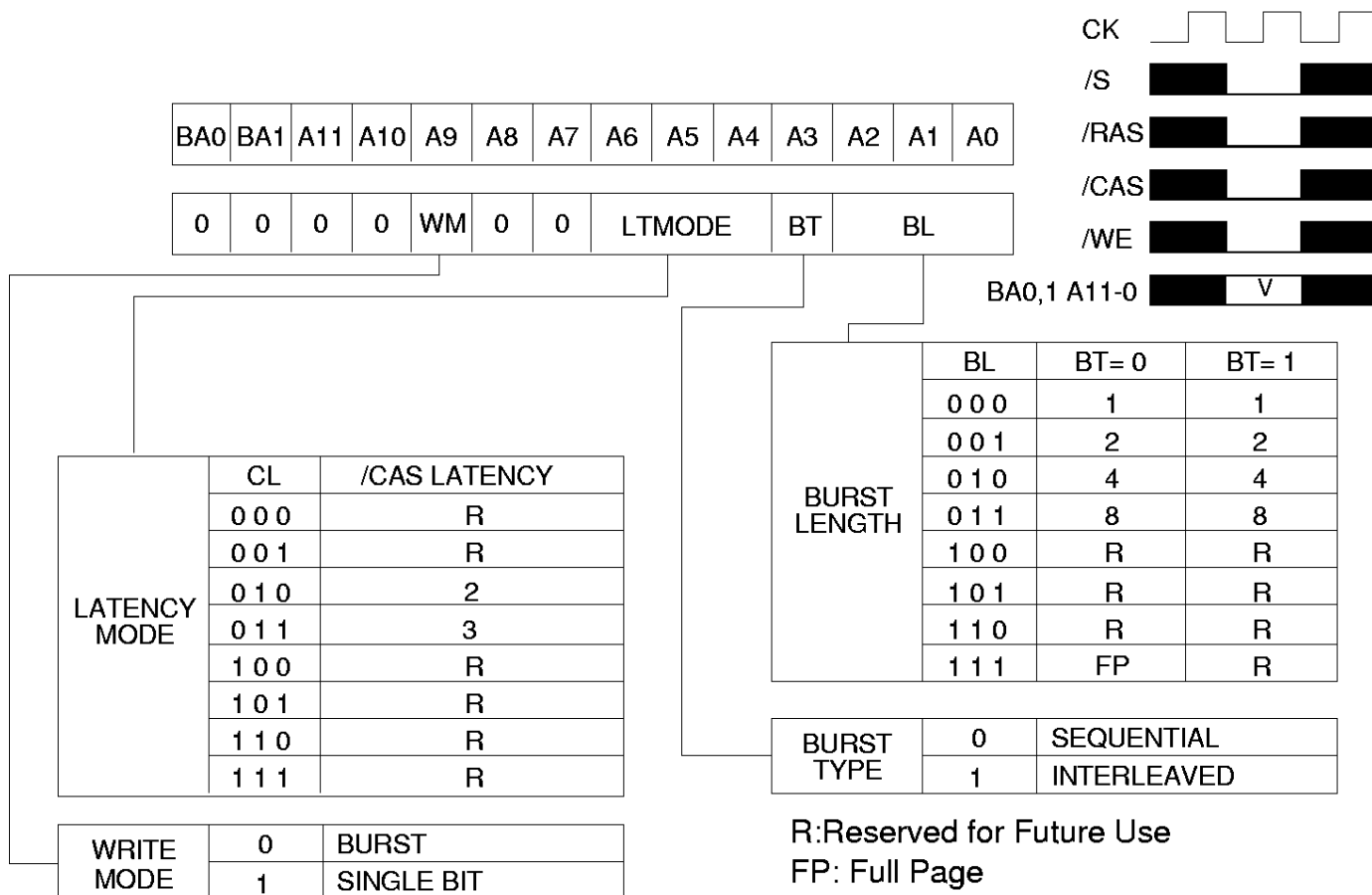

MH8S64QFC -7,-7L,-8,-8L,-10,-10L

536870912-BIT (8388608 - WORD BY 64-BIT) Synchronous DRAM

[/CAS LATENCY]

/CAS latency, CL, is used to synchronize the first output data with the CLK frequency, i.e., the speed of CLK determines which CL should be used. First output data is available after CL cycles from READ command.

/CAS Latency Timing (BL=4)

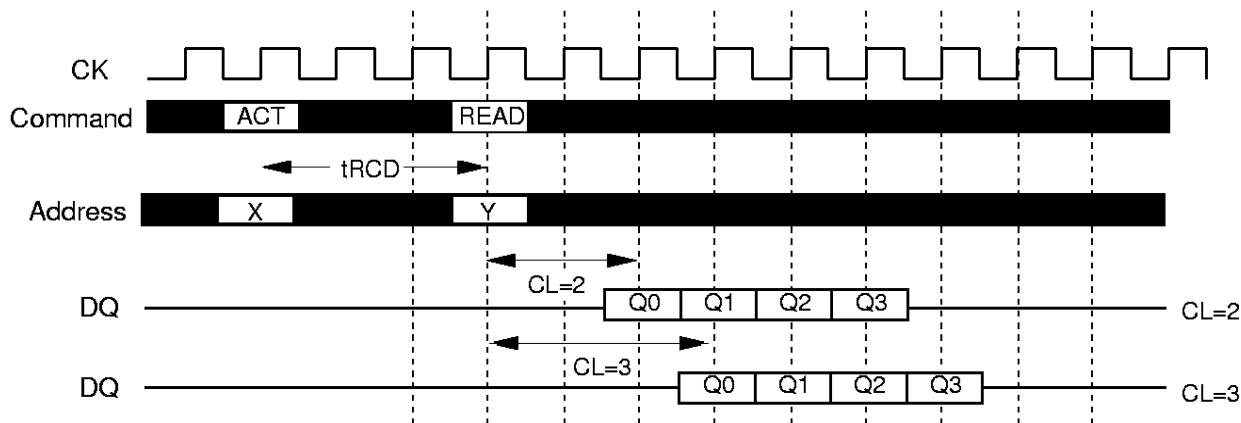

[BURST LENGTH]

The burst length, BL, determines the number of consecutive writes or reads that will be automatically performed after the initial write or read command. For BL=1,2,4,8, full page the output data is tristated (Hi-Z) after the last read. For BL=FP (Full Page), the TBST (Burst Terminate) command should be issued to stop the output of data.

Burst Length Timing (CL=2)

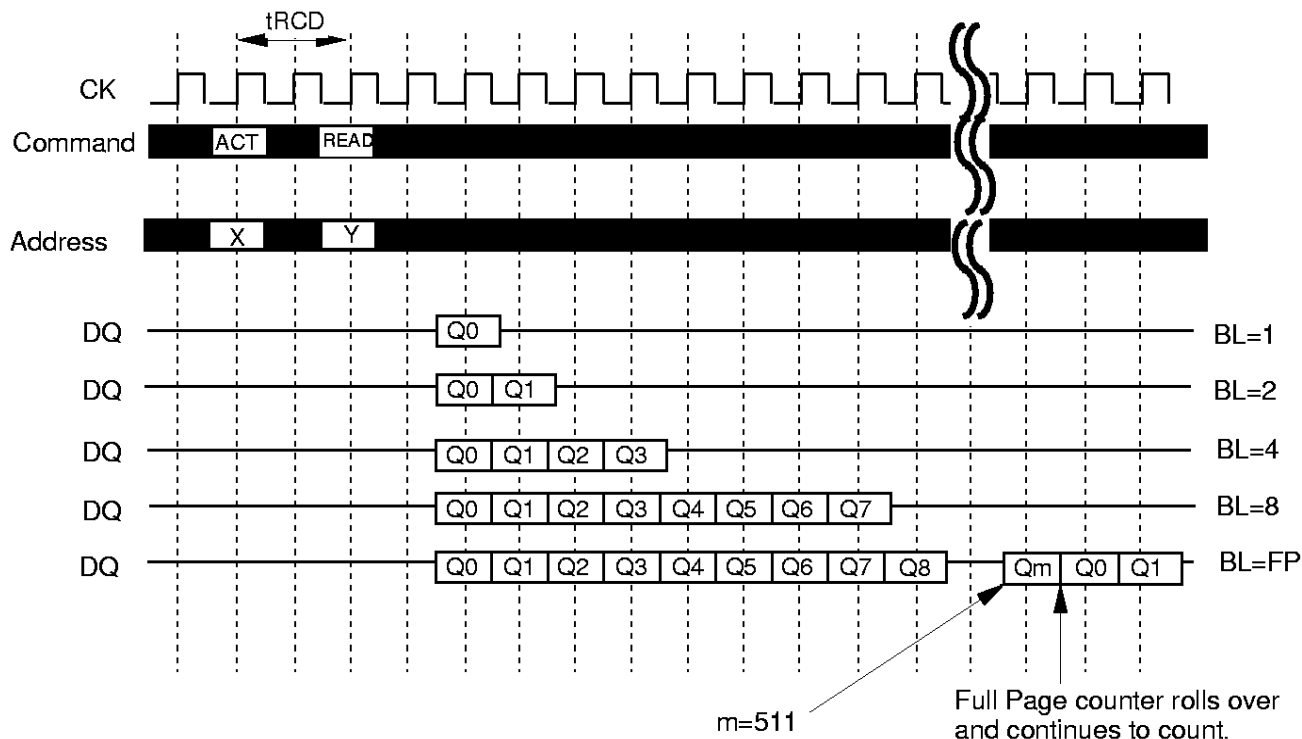

MH8S64QFC -7,-7L,-8,-8L,-10,-10L

536870912-BIT (8388608 - WORD BY 64-BIT) Synchronous DRAM

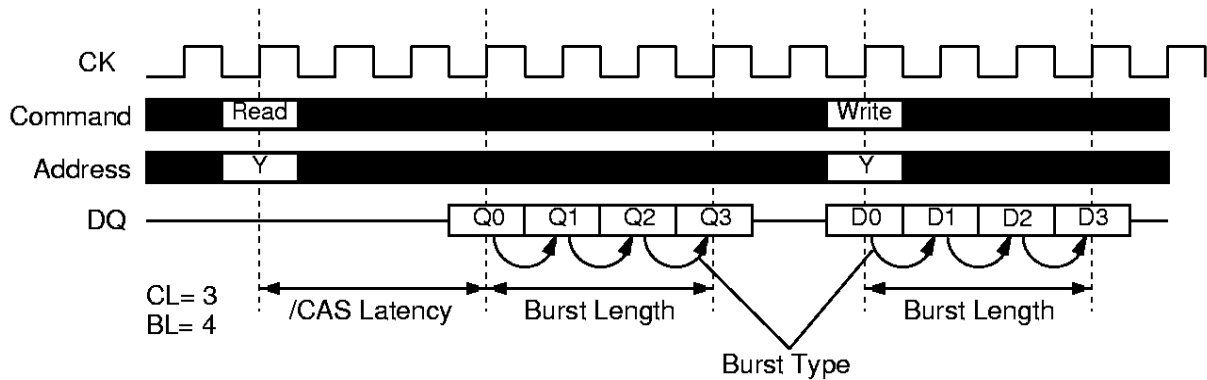

Initial Address			BL	Column Addressing															
A2	A1	A0		Sequential							Interleaved								
0	0	0	8	0	1	2	3	4	5	6	7	0	1	2	3	4	5	6	7
0	0	1		1	2	3	4	5	6	7	0	1	0	3	2	5	4	7	6
0	1	0		2	3	4	5	6	7	0	1	2	3	0	1	6	7	4	5
0	1	1		3	4	5	6	7	0	1	2	3	2	1	0	7	6	5	4
1	0	0		4	5	6	7	0	1	2	3	4	5	6	7	0	1	2	3
1	0	1		5	6	7	0	1	2	3	4	5	4	7	6	1	0	3	2
1	1	0		6	7	0	1	2	3	4	5	6	7	4	5	2	3	0	1
1	1	1		7	0	1	2	3	4	5	6	7	6	5	4	3	2	1	0
-	0	0	4	0	1	2	3					0	1	2	3				
-	0	1		1	2	3	0					1	0	3	2				
-	1	0		2	3	0	1					2	3	0	1				
-	1	1		3	0	1	2					3	2	1	0				
-	-	0	2	0	1							0	1						
-	-	1		1	0							1	0						

OPERATION DESCRIPTION

BANK ACTIVATE

The SDRAM has four independent banks. Each bank is activated by the ACT command with the bank address (BA0,1). A row is indicated by the row address A11-0. The minimum activation interval between one bank and the other bank is tRRD. The number of banks which are active concurrently is not limited.

PRECHARGE

The PRE command deactivates indicated by BA. When both banks are active, the precharge all command (PREA, PRE + A10=H) is available to deactivate them at the same time. After tRP from the precharge, an ACT command can be issued.

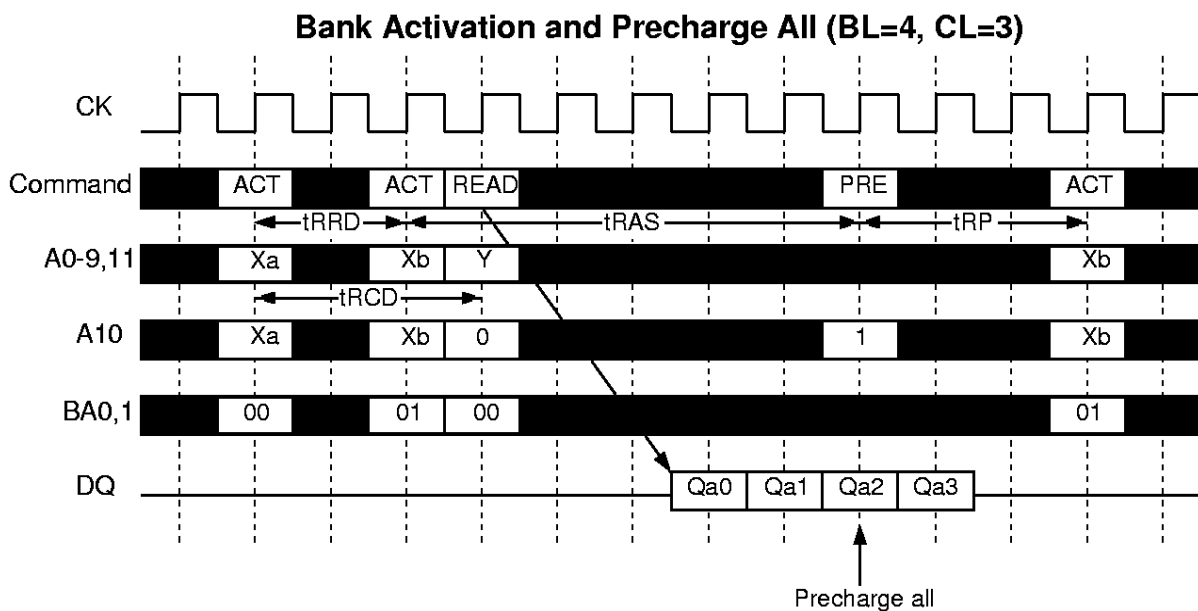

READ

After tRCD from the bank activation, a READ command can be issued. 1st output date is available after the /CAS Latency from the READ, followed by (BL-1) consecutive date when the Burst Length is BL. The start address is specified by A8-0, and the address sequence of burst data is defined by the Burst Type. A READ command may be applied to any active bank, so the row precharge time (tRP) can be hidden behind continuous output data (in case of BL=8) by interleaving the dual banks. When A10 is high at a READ command, the auto-precharge (READA) is performed. Any command (READ, WRITE, PRE, ACT) to the same bank is inhibited till the internal precharge is complete. The internal precharge start at BL after READA. The next ACT command can be issued after (BL + tRP) from the previous READA.

MH8S64QFC -7,-7L,-8,-8L,-10,-10L

536870912-BIT (8388608 - WORD BY 64-BIT) Synchronous DRAM

Multi Bank Interleaving READ (BL=4, CL=3)

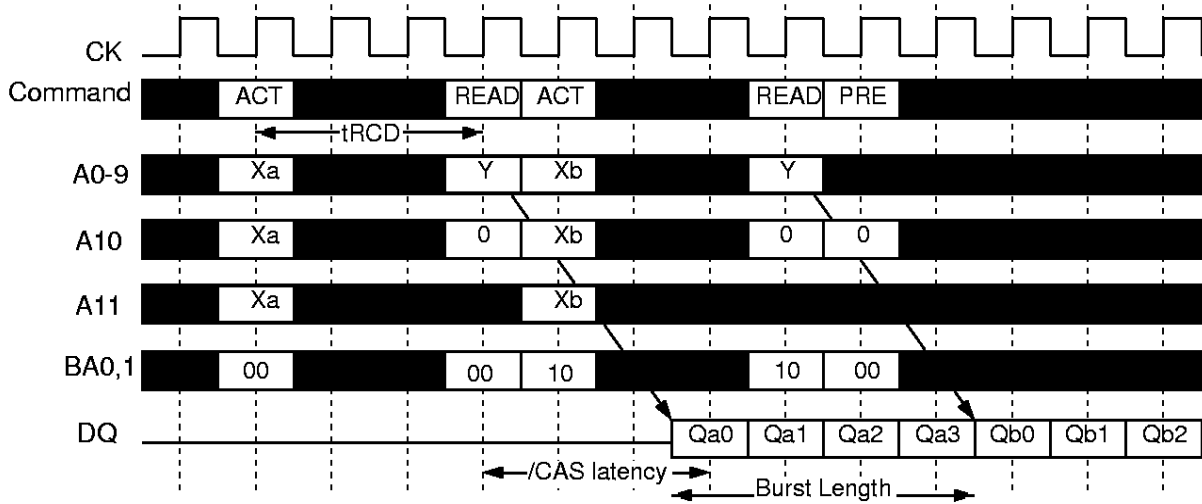

READ with Auto-Precharge (BL=4, CL=3)

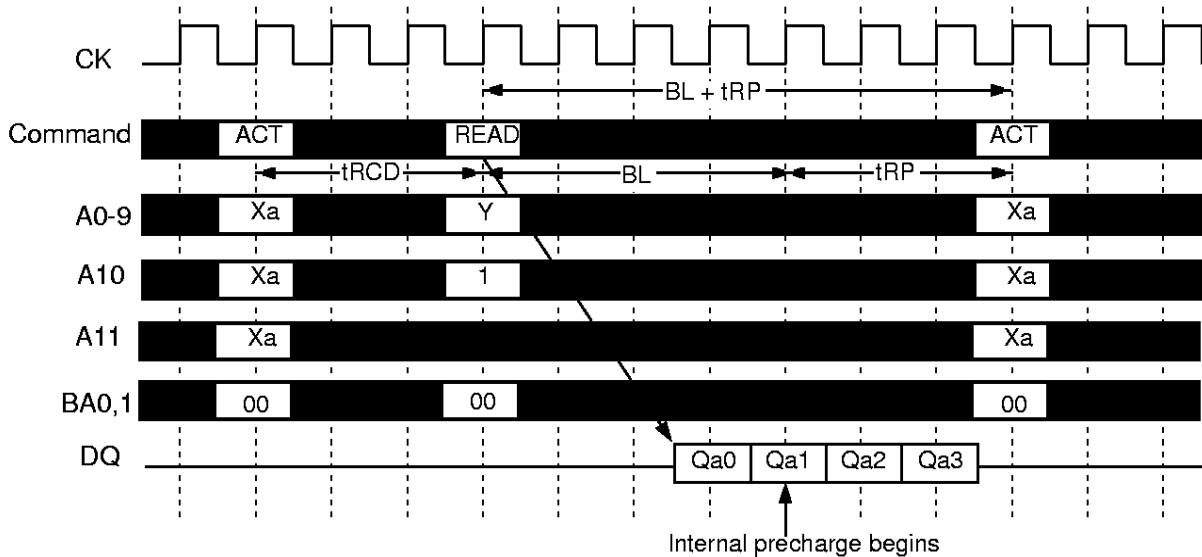

READ Auto-Precharge Timing (BL=4)

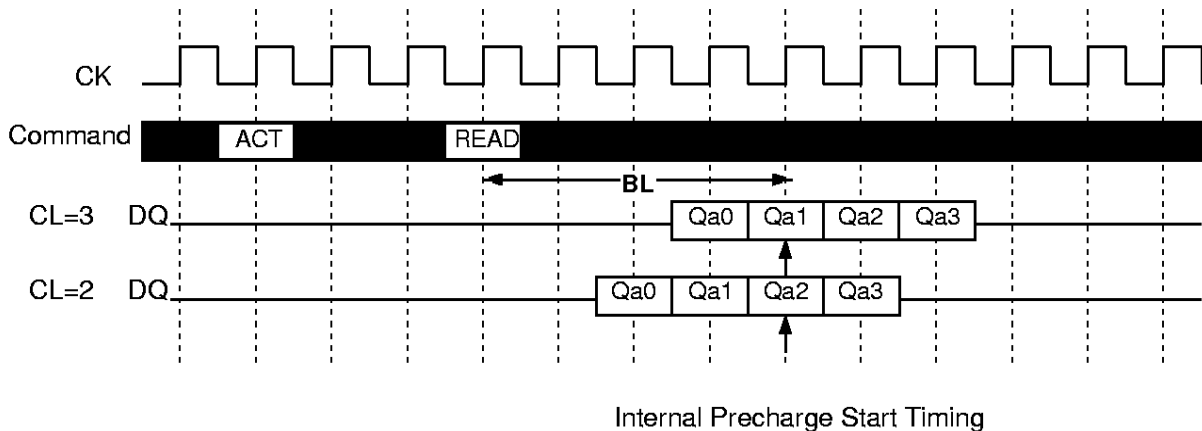

MH8S64QFC -7,-7L,-8,-8L,-10,-10L

536870912-BIT (8388608 - WORD BY 64-BIT) Synchronous DRAM

WRITE

After t_{RCD} from the bank activation, a WRITE command can be issued. 1st input data is set at the same cycle as the WRITE. Following $(BL-1)$ data are written into the RAM, when the Burst Length is BL. The start address is specified by A8-0, and the address sequence of burst data is defined by the Burst Type. A WRITE command may be applied to any active bank, so the row precharge time (t_{RP}) can be hidden behind continuous input data by interleaving the multiple banks. From the last input data to the PRE command, the write recovery time (t_{WR}) is required. When A10 is high at a WRITE command, the auto-precharge (WRITEA) is performed. Any command (READ, WRITE, PRE, ACT) to the same bank is inhibited till the internal precharge is complete. The internal precharge begins at t_{WR} after the last input data cycle. The next ACT command can be issued after t_{RP} from the internal precharge timing. The Mode Register can be WRITE command is issued and the remaining burst length is ignored. The read data burst length is unaffected while in this mode.

Multi Bank Interleaving WRITE (BL=4)

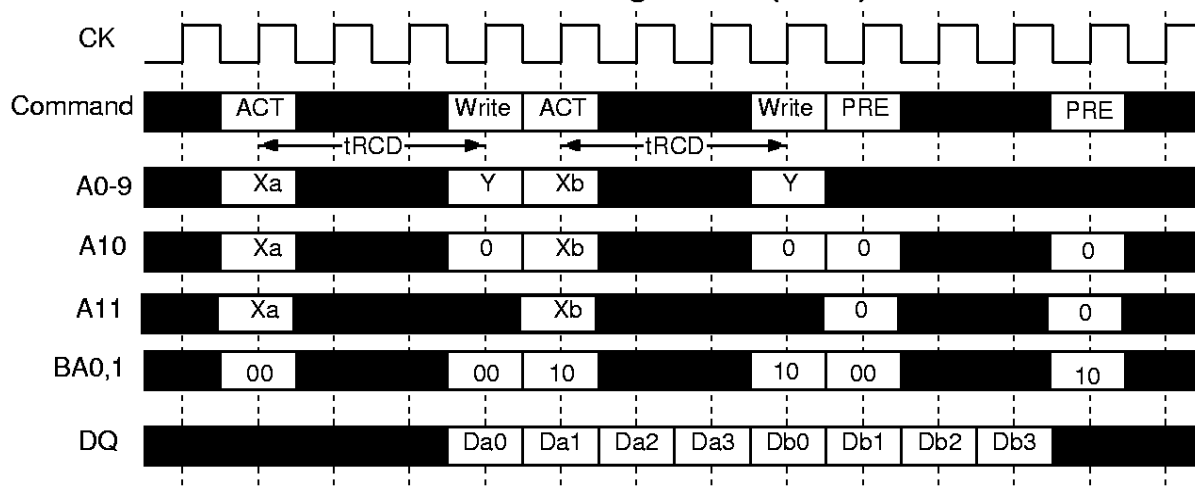

WRITE with Auto-Precharge (BL=4)

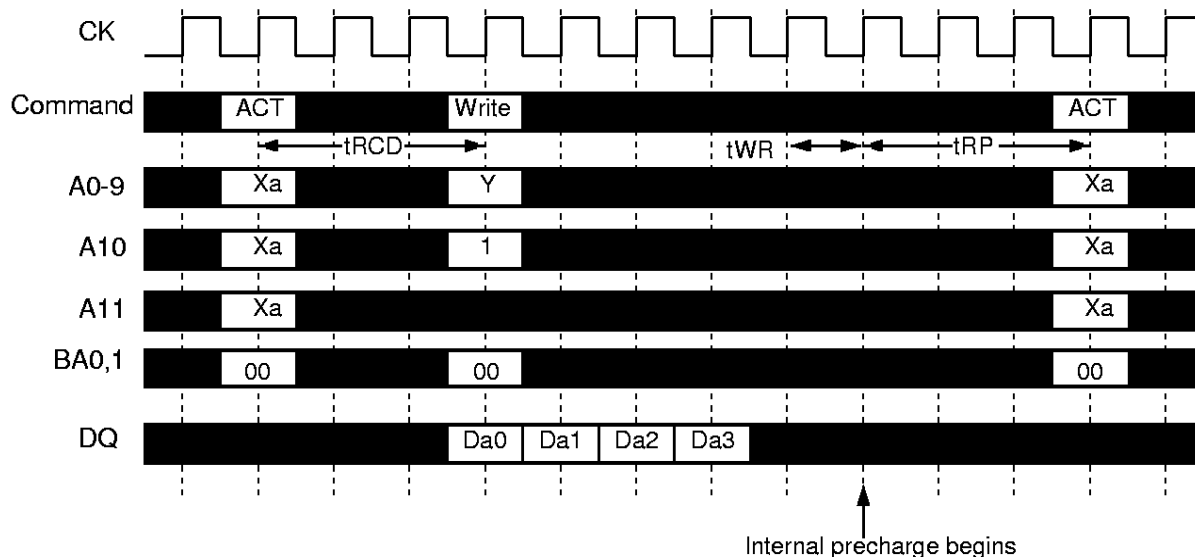

MH8S64QFC -7,-7L,-8,-8L,-10,-10L

536870912-BIT (8388608 - WORD BY 64-BIT) Synchronous DRAM

[BURST WRITE]

A burst write operation is enabled by setting A9=0 at MRS. A burst write starts in the same cycle as a write command set. (The latency of data input is 0.) The burst length can be set to 1, 2, 4, 8, and full-page, like burst read operations.

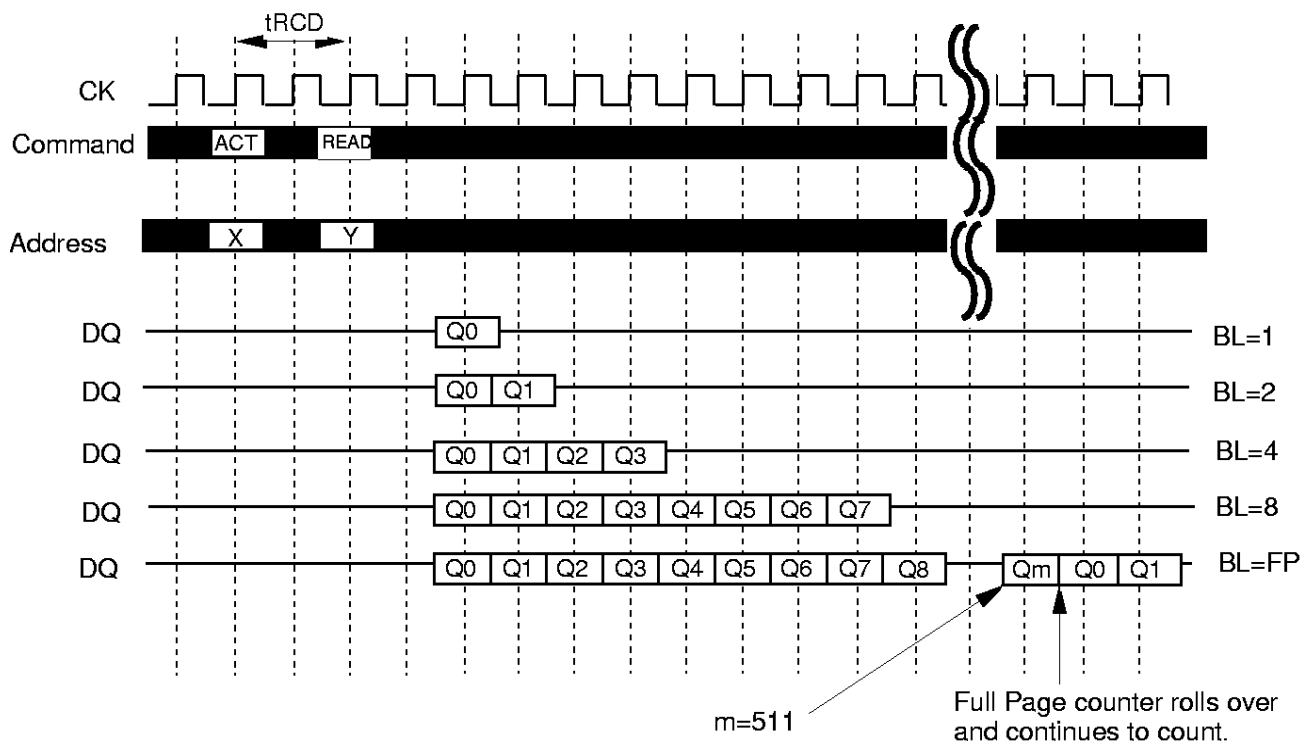

[SINGLE WRITE]

A single write operation is enabled by setting A9=1 at MRS. In a single write operation, data is written only to the column address specified by the write command set cycle without regard to the burst length setting. (The latency of data input is 0.)

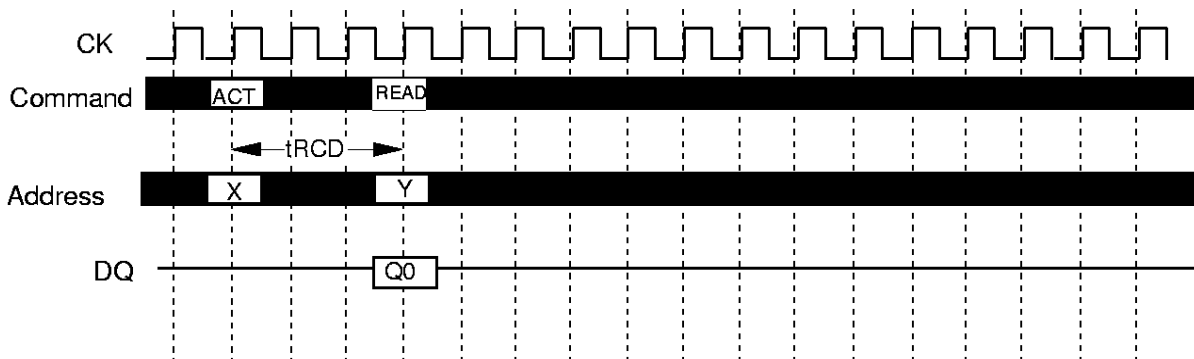

MH8S64QFC -7,-7L,-8,-8L,-10,-10L

536870912-BIT (8388608 - WORD BY 64-BIT) Synchronous DRAM

BURST INTERRUPTION

[Read Interrupted by Read]

Burst read option can be interrupted by new read of the same or the other bank. Random column access is allowed. READ to READ interval is minimum 1 CK

Read Interrupted by Read (BL=4, CL=3)

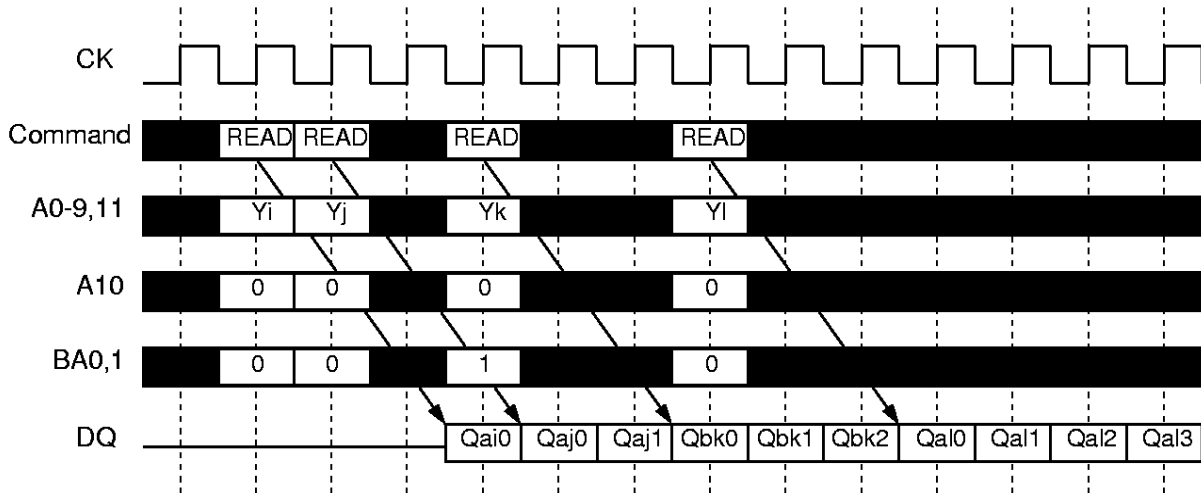

[Read Interrupted by Write]

Burst read operation can be interrupted by write of the same or the other bank. Random column access is allowed. In this case, the DQ should be controlled adequately by using the DQMB0-7 to prevent the bus contention. The output is disabled automatically 2 cycle after WRITE assertion.

Read Interrupted by Write (BL=4, CL=3)

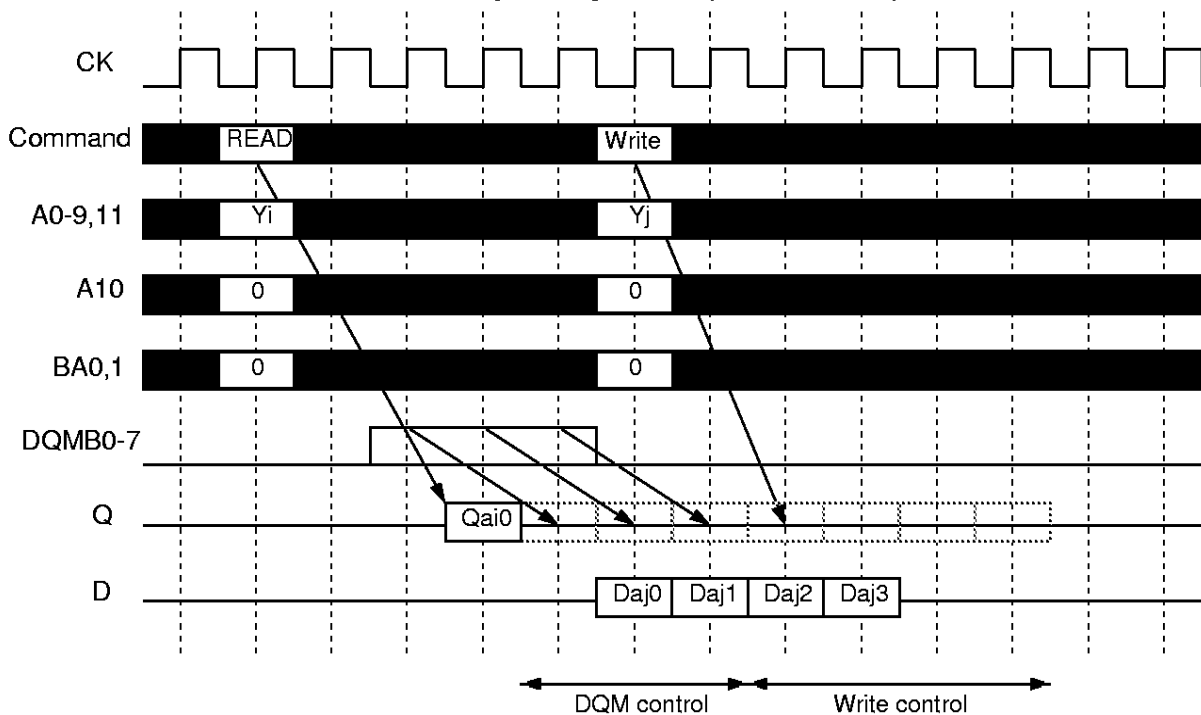

MH8S64QFC -7,-7L,-8,-8L,-10,-10L

536870912-BIT (8388608 - WORD BY 64-BIT) Synchronous DRAM

[Read Interrupted by Precharge]

Burst read operation can be interrupted by precharge of the same or the other bank. Read to PRE interval is minimum 1 CK. A PRE command output disable latency is equivalent to the /CAS Latency. As a result, READ to PRE interval determines valid data length to be output. The figure below shows examples of BL=4.

Read Interrupted by Precharge (BL=4)

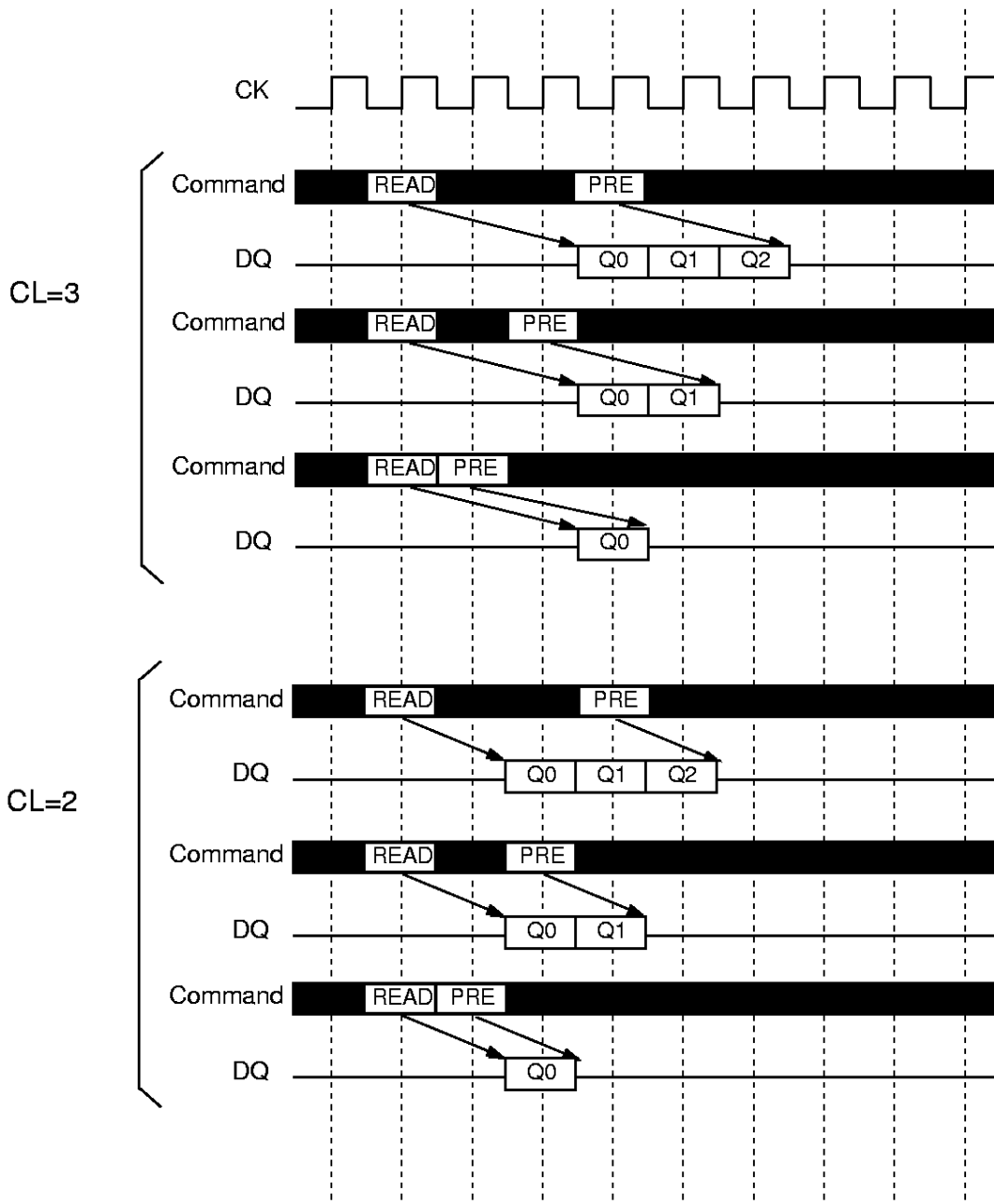

MH8S64QFC -7,-7L,-8,-8L,-10,-10L

536870912-BIT (8388608 - WORD BY 64-BIT) Synchronous DRAM

[Read Interrupted by Burst Terminate]

Similarly to the precharge, burst terminate command, TBST, can interrupt burst read operation and disable the data output. READ to TBST interval is minimum of 1 CK. TBST is mainly used to interrupt FP bursts. The figure below show examples, of how the output data is terminated with TBST.

Read Interrupted by Burst Terminate (BL=4)

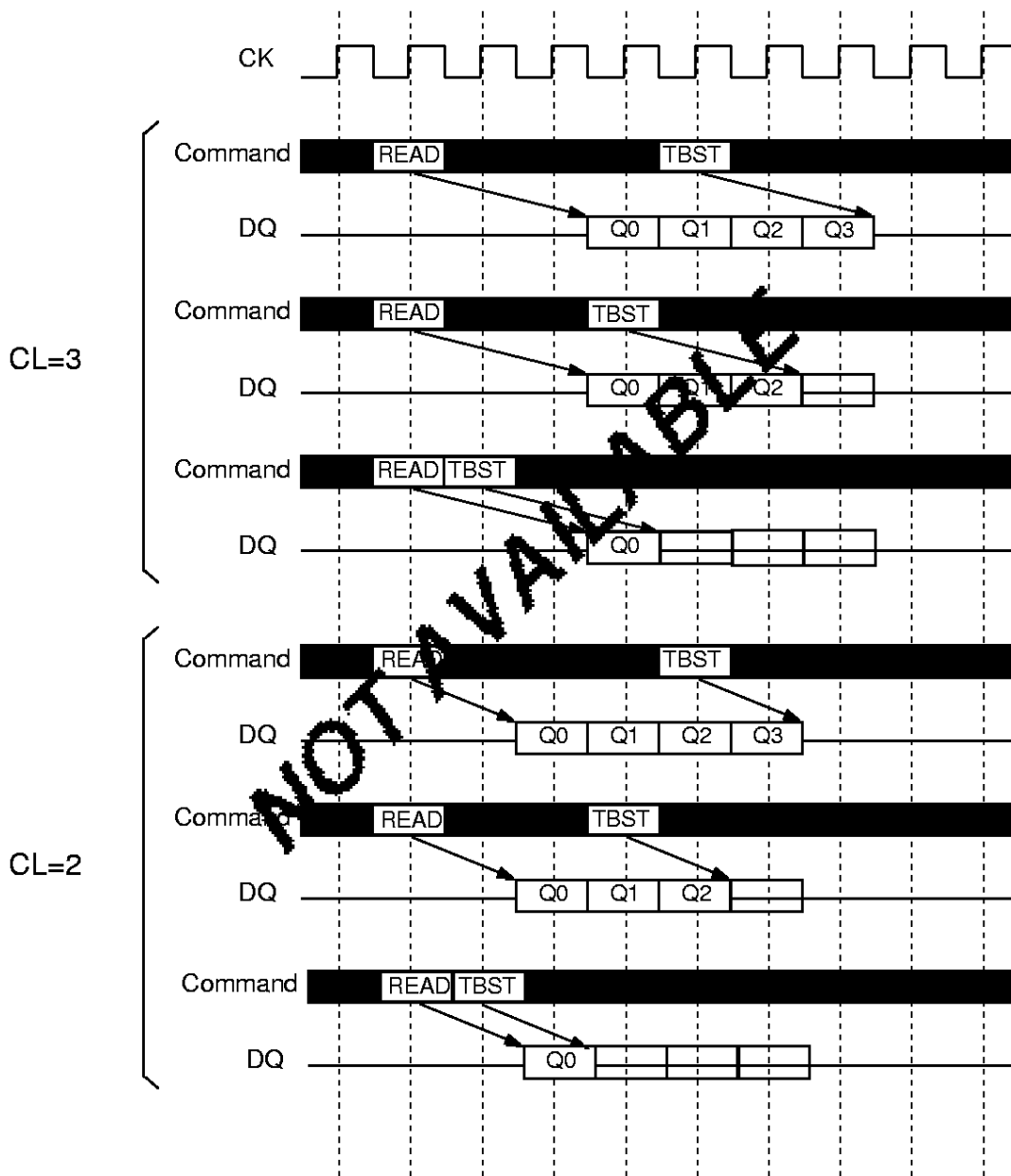

[Write Interrupted by Write]

Burst write operation can be interrupted by new write of the same or the other bank. Random column access is allowed. WRITE to WRITE interval is minimum 1 CK.

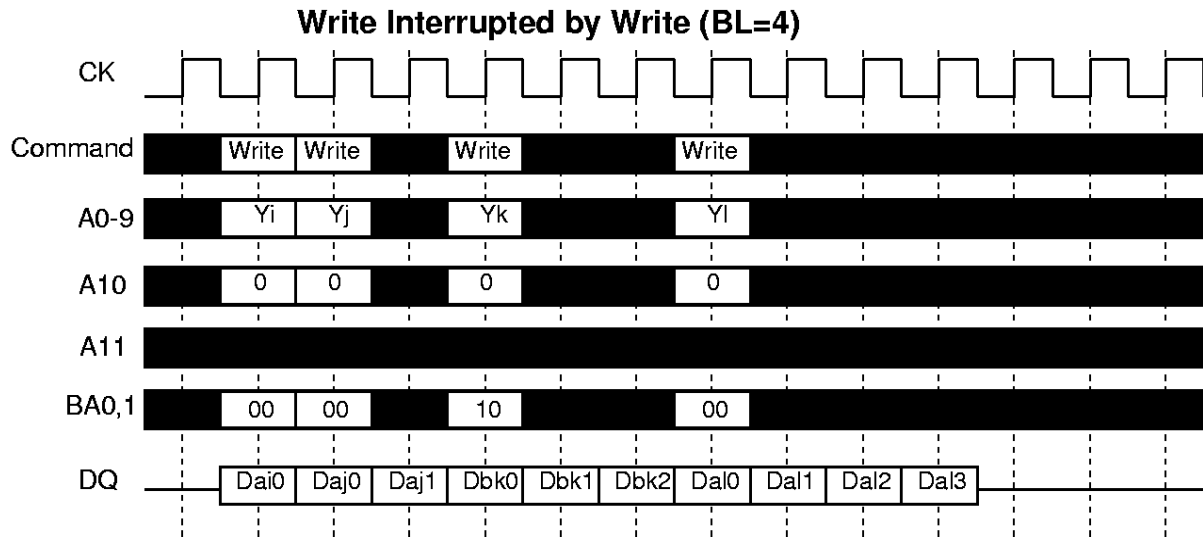

[Write Interrupted by Read]

Burst write operation can be interrupted by read of the same or the other bank. Random column access is allowed. WRITE to READ interval is minimum 1 CK. The input data on DQ at the interrupting READ cycle is "don't care".

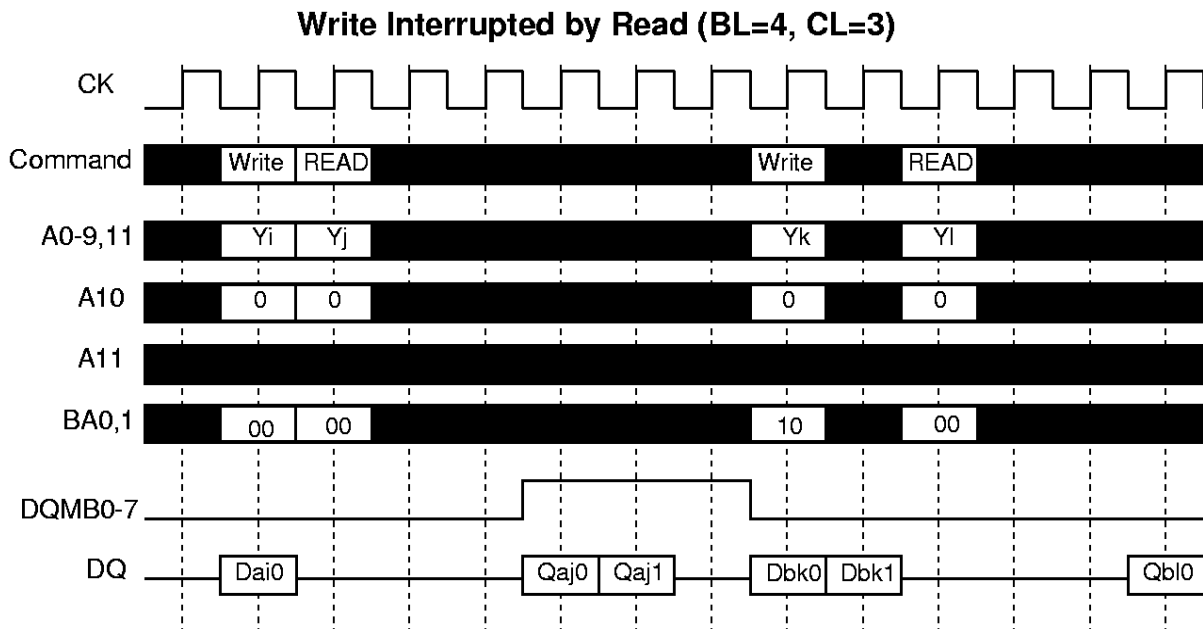

[Write Interrupted by Precharge]

Burst write operation can be interrupted by precharge of the same bank. Random column access is allowed. Because the write recovery time (t_{WR}) is required from the last data to PRE command.

Write Interrupted by Precharge (BL=4)

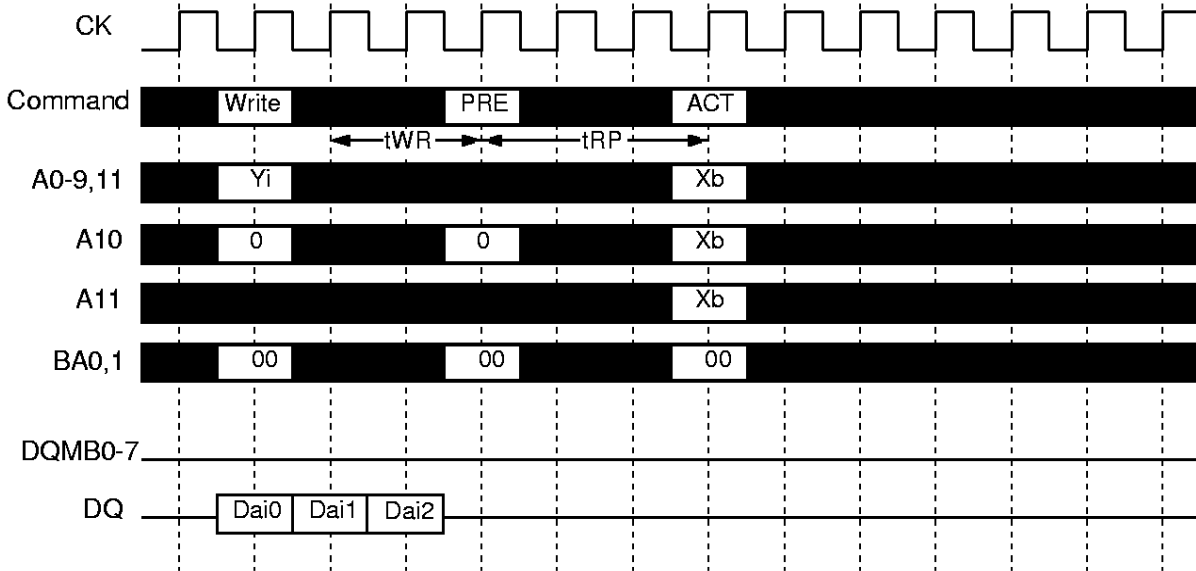

[Write Interrupted by Burst Terminate]

A burst terminate command TBST can terminate burst write operation. In this case, the write recovery time is not required and the bank remains active (Please see the waveforms below). The WRITE to TBST minimum interval is 1CK.

Write Interrupted by Burst Terminate (BL=4)

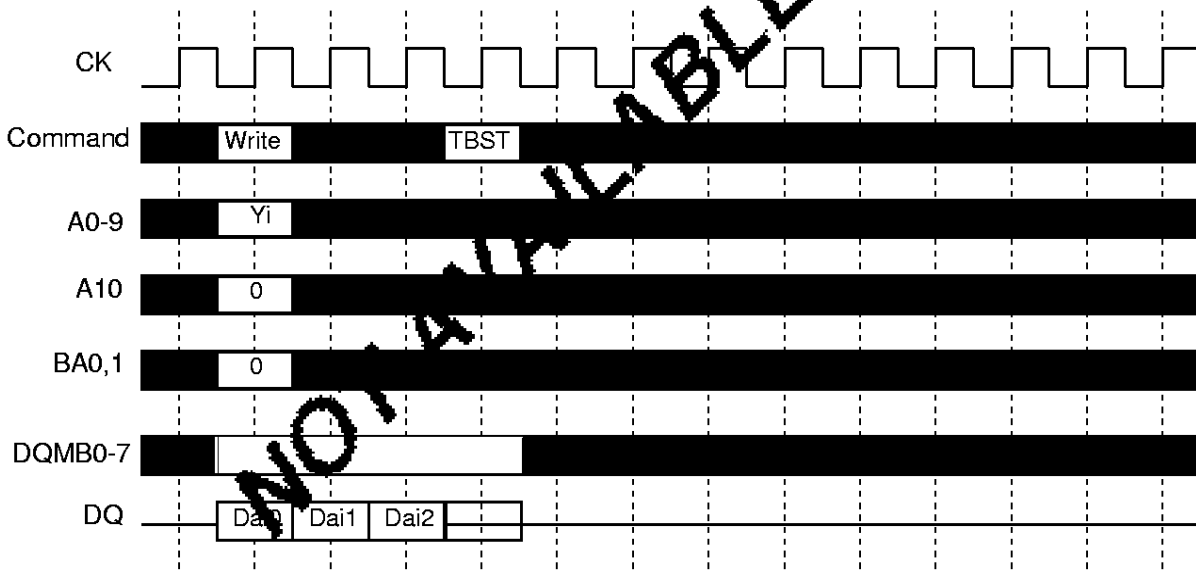

AUTO REFRESH

Single cycle of auto-refresh is initiated with a REFA(/CS=/RAS=/CAS=L, /WE=/CKE=H) command. The refresh address is generated internally. 4096 REFA cycle within 64ms refresh 128Mbit memory cells. The auto-refresh is performed on 4bank alternately(ping-pong refresh). Before performing an auto-refresh, both banks must be in the idle state. Additional commands must not be supplied to the device before tRC from the REFA command.

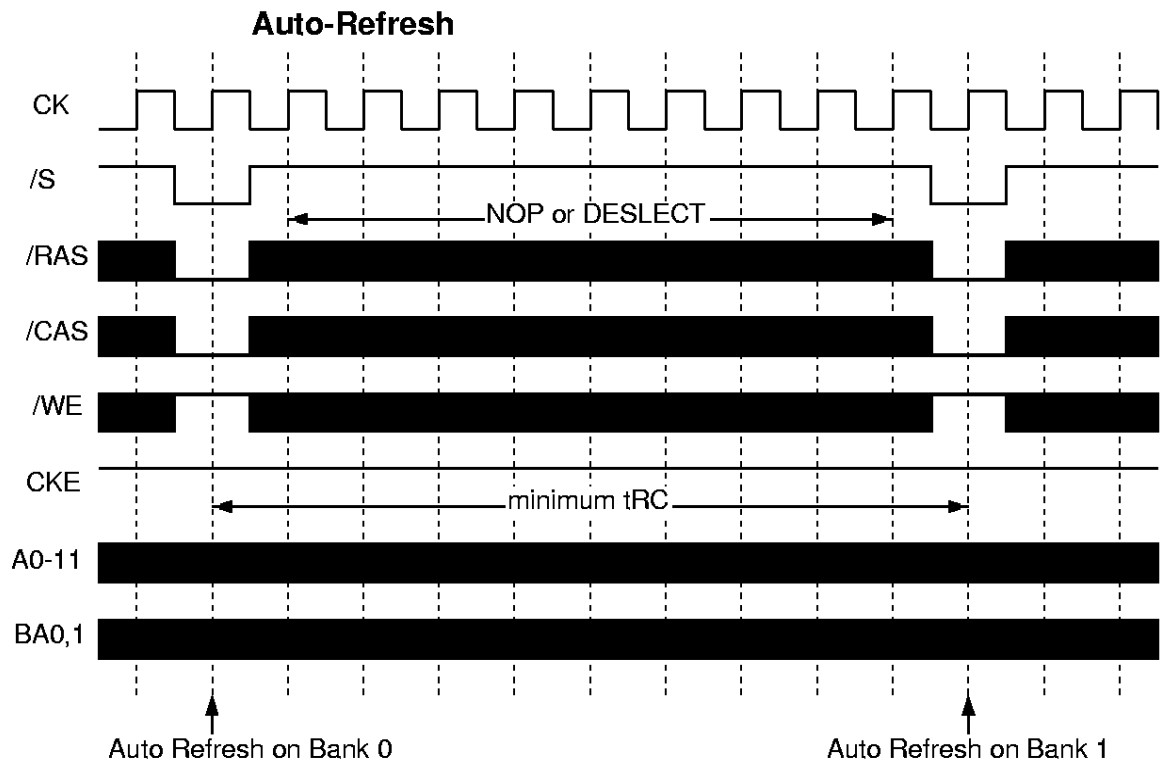

SELF REFRESH

Self-refresh mode is entered by issuing a REFS command ($/CS=/RAS=/CAS=L$, $/WE=H$, $CKE=L$). Once the self-refresh is initiated, it is maintained as long as CKE is kept low. During the self-refresh mode, CKE is asynchronous and the only enabled input, all other inputs including CK are disabled and ignored, so that power consumption due to synchronous inputs is saved. To exit the self-refresh, supplying stable CK inputs, asserting $DESEL$ or NOP command and then asserting $CKE(REFSX)$ for longer than $tSRX$. After tRC from $REFSX$ all banks are in the idle state and a new command can be issued after tRC , but $DESEL$ or NOP commands must be asserted till then.

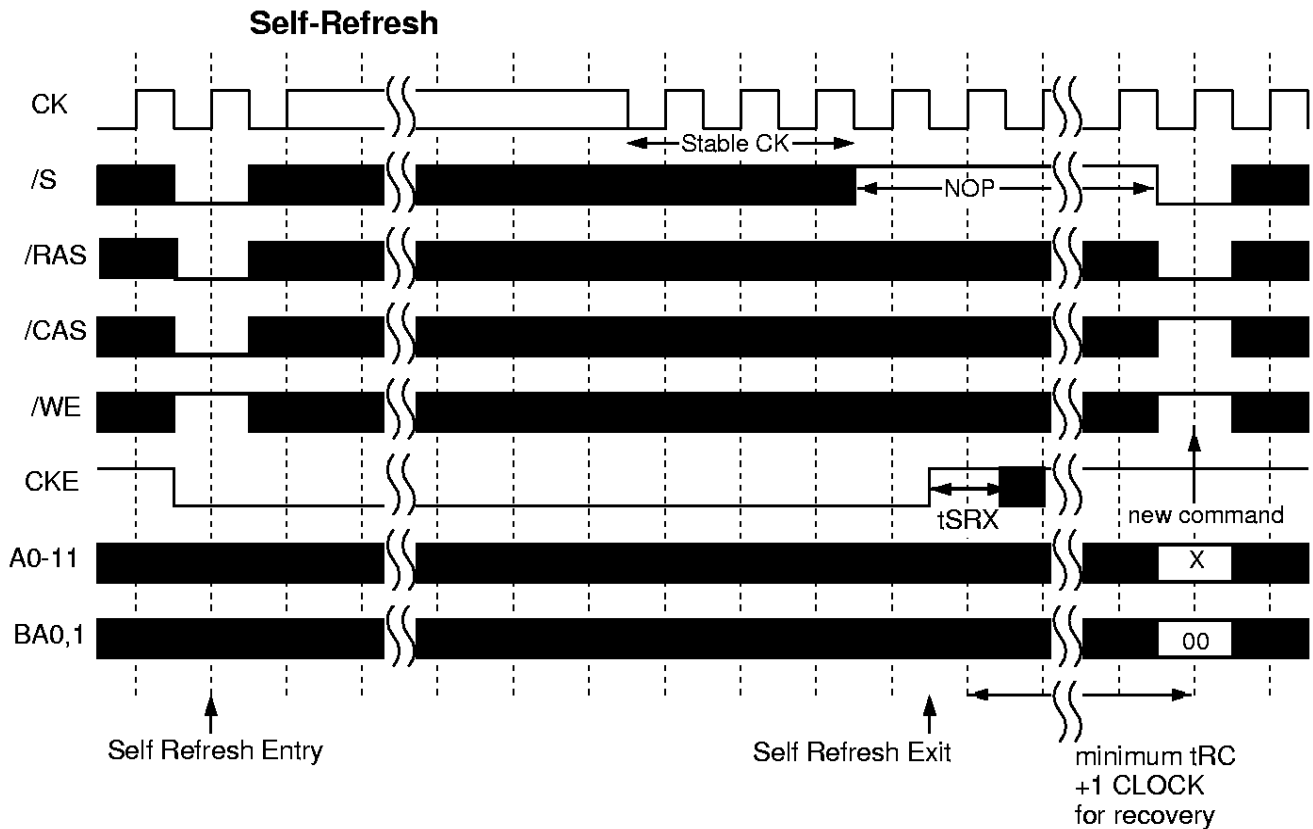

CLK SUSPEND

CKE controls the internal CLK at the following cycle. Figure below shows how CKE works. By negating CKE, the next internal CLK is suspended. The purpose of CLK suspend is power down, output suspend or input suspend. CKE is a synchronous input except during the self-refresh mode. CLK suspend can be performed either when the banks are active or idle, but a command at the following cycle is ignored.

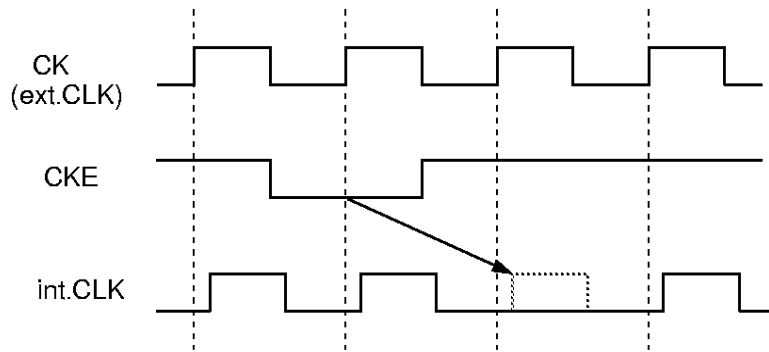

Power Down by CKE

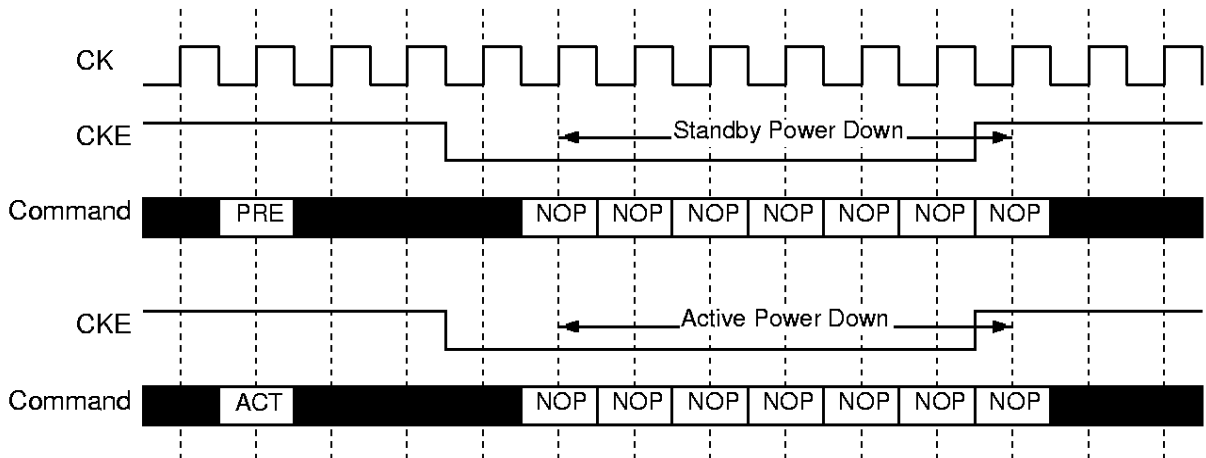

DQ Suspend by CKE

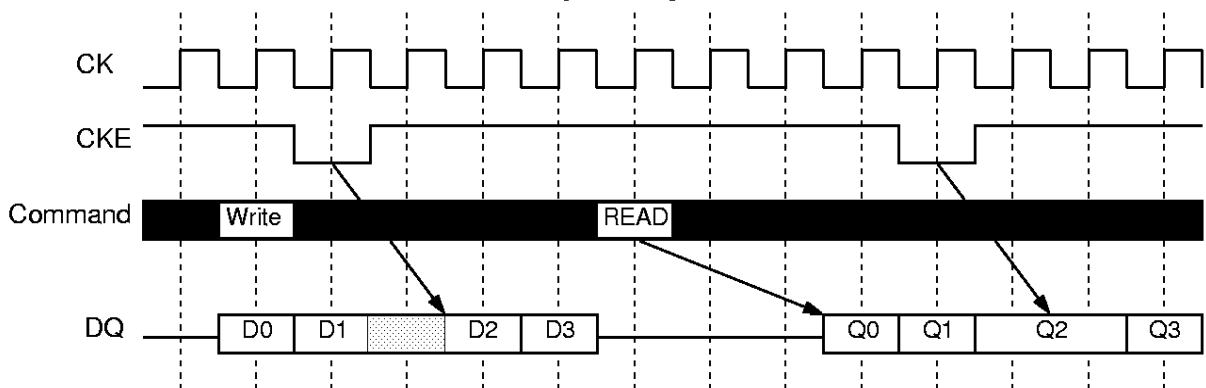

DQM CONTROL

DQMB0-7 is a dual function signal defined as the data mask for writes and the output disable for reads. During writes, DQMB0-7 masks input data word by word. DQMB0-7 to write mask latency is 0.

During reads, DQMB0-7 forces output to Hi-Z word by word. DQMB0-7 to output Hi-Z latency is 2.

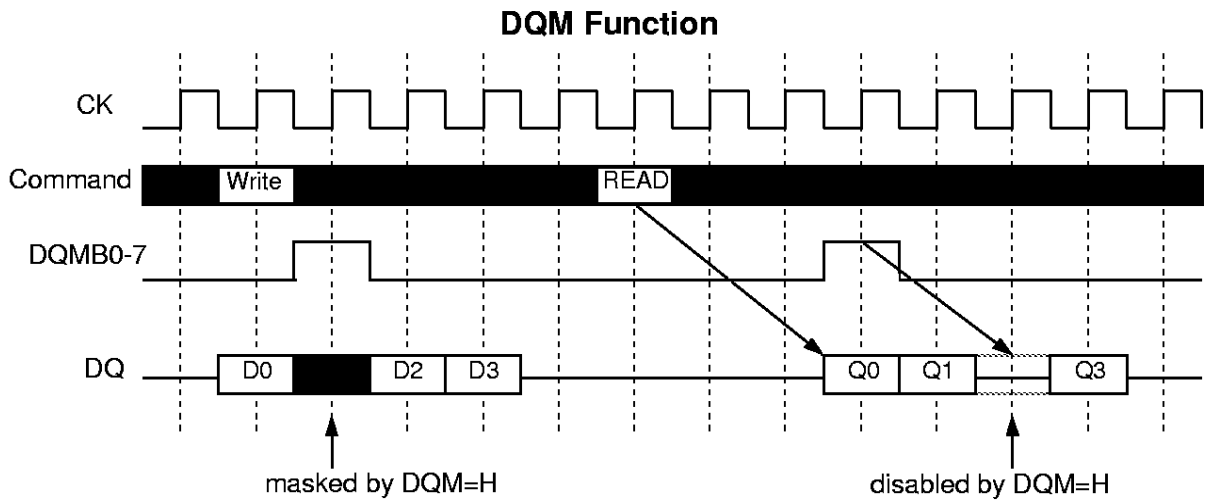

MH8S64QFC -7,-7L,-8,-8L,-10,-10L

536870912-BIT (8388608 - WORD BY 64-BIT) Synchronous DRAM

ABSOLUTE MAXIMUM RATINGS

Symbol	Parameter	Condition	Ratings	Unit
Vdd	Supply Voltage	with respect to Vss	-0.5 ~ 4.6	V
VI	Input Voltage	with respect to Vss	-0.5 ~ 4.6	V
VO	Output Voltage	with respect to Vss	-0.5 ~ 4.6	V
IO	Output Current		50	mA
Pd	Power Dissipation	Ta=25°C	4	W
Topr	Operating Temperature		0 ~ 70	°C
Tstg	Storage Temperature		-40 ~ 100	°C

RECOMMENDED OPERATING CONDITION

(Ta=0 ~ 70°C, unless otherwise noted)

Symbol	Parameter	Limits			Unit
		Min.	Typ.	Max.	
Vdd	Supply Voltage	3.0	3.3	3.6	V
Vss	Supply Voltage	0	0	0	V
VIH	High-Level Input Voltage all inputs	2.0		Vdd+0.3	V
VIL	Low-Level Input Voltage all inputs	-0.3		0.8	V

Note:* VIH (max) = 5.5V for pulse width less than 10ns.

VIL (min) = -1.0V for pulse width less than 10ns.

CAPACITANCE

(Ta=0 ~ 70°C, Vdd = 3.3 ± 0.3V, Vss = 0V, unless otherwise noted)

Symbol	Parameter	Test Condition	Limits(max.)	Unit
CI(A)	Input Capacitance, address pin	VI = Vss f=1MHz Vi=25mVrms	35	pF
CI(C)	Input Capacitance, control pin		35	pF
CI(K)	Input Capacitance, CK pin		35	pF
CI/O	Input Capacitance, I/O pin		22	pF

MH8S64QFC -7,-7L,-8,-8L,-10,-10L

536870912-BIT (8388608 - WORD BY 64-BIT) Synchronous DRAM

AVERAGE SUPPLY CURRENT from Vdd

(Ta=0 ~70°C, Vdd = 3.3 ± 0.3V, Vss = 0V, unless otherwise noted)

Parameter	Symbol	Test Condition	Limits (max)		Unit	Note
			-7,-7L -8,-8L	-10,-10L		
operating current one bank active (discrete)	Icc1	tRC=min,tCLK=min, BL=1, loL=min	540	420	mA	*1
precharge stanby current in power-down mode /CS>Vcc-0.2V	Icc2P	CKE=L,tCLK=min	8	8	mA	*1
	Icc2PS	CKE=CLK=L	4	4	mA	*1
precharge stanby current in non power-down mode /CS>Vcc-0.2V	Icc2N	tCLK=min,CKE=H,VIH>Vcc-0.2V,VIL<0.2V	80	80	mA	*1
	Icc2NS	CLK=L&CKE=H,VIH>Vcc-0.2V,VIL<0.2V all input signals are fixed.	32	32	mA	*1
active stanby current in power-down mode	Icc3P	CKE=L, tCLK=min	20	20	mA	*1
	Icc3PS	CKE=L, CLK=L	20	20	mA	*1
active stanby current in non power-down mode	Icc3N	CKE=H, tCLK=min	120	100	mA	*1
	Icc3NS	CKE=H, CLK=L	100	80	mA	*1
burst current	Icc4	tCLK=min, BL=4, CL=3 Aall banks active(discerte)	640	640	mA	*1
auto-refresh current	Icc5	tRC=min, tCLK=min	720	560	mA	*1
self-refresh current	Icc6	CKE <0.2V	4	4	mA	*1
			2.4	2.4	mA	*1,2

Note1:Icc(max) is specified at the output open condition.

Note2:Low Power version

AC OPERATING CONDITIONS AND CHARACTERISTICS

(Ta=0 ~ 70°C, Vdd = 3.3 ± 0.3V, Vss = 0V, unless otherwise noted)

Symbol	Parameter	Test Condition	Limits		Unit
			Min.	Max.	
VOH(DC)	High-Level Output Voltage(DC)	IOH=-2mA	2.4		V
VOL(DC)	Low-Level Output Voltage(DC)	IOL=2mA		0.4	V
IOZ	Off-stare Output Current	Q floating VO=0 ~ Vdd	-10	10	uA
Ii	Input Current	VIH=0 ~ Vdd+0.3V	-40	40	uA

MH8S64QFC -7,-7L,-8,-8L,-10,-10L

536870912-BIT (8388608 - WORD BY 64-BIT) Synchronous DRAM

AC TIMING REQUIREMENTS (SDRAM Component)

($T_a=0 \sim 70^\circ\text{C}$, $V_{dd} = 3.3 \pm 0.3\text{V}$, $V_{ss} = 0\text{V}$, unless otherwise noted)

Input Pulse Levels: 0.8V to 2.0V

Input Timing Measurement Level: 1.4V

Symbol	Parameter	Limits						Unit	
		-7,-7L		-8,-8L		-10,-10L			
		Min.	Max.	Min.	Max.	Min.	Max.		
tCLK	CK cycle time	CL=2	10		13		15		ns
		CL=3	10		10		10		ns
tCH	CK High pulse width	3		3		4		ns	
tCL	CK Low pulse width	3		3		4		ns	
tT	Transition time of CK	1	10	1	10	1	10	ns	
tIS	Input Setup time(all inputs)	2		2		3		ns	
tIH	Input Hold time(all inputs)	1		1		1		ns	
tRC	Row cycle time	70		70		90		ns	
tRCD	Row to Column Delay	20		20		30		ns	
tRAS	Row Active time	50	100K	50	100K	60	100K	ns	
tRP	Row Precharge time	20		20		30		ns	
tWR	Write Recovery time	10		10		10		ns	
tRRD	Act to Act Delay time	20		20		20		ns	
tRSC	Mode Register Set Cycle time	20		20		20		ns	
tSRX	Self Refresh Exit time	10		10		10		ns	
tPDE	Power Down Exit time	10		10		10		ns	
tREF	Refresh Interval time		64		64		64	ms	

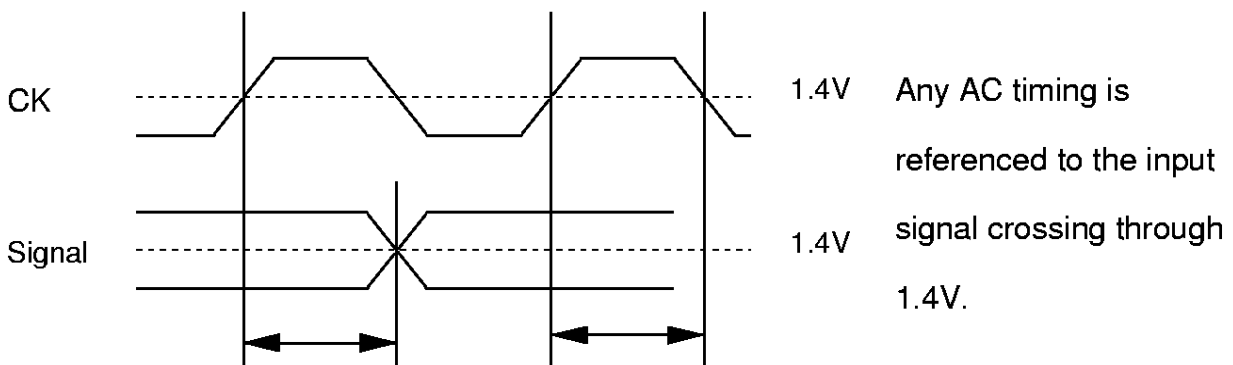

MH8S64QFC -7,-7L,-8,-8L,-10,-10L

536870912-BIT (8388608 - WORD BY 64-BIT) Synchronous DRAM

SWITCHING CHARACTERISTICS (SDRAM Component)

($T_a=0 \sim 70^\circ\text{C}$, $V_{dd} = 3.3 \pm 0.165\text{V}$, $V_{ss} = 0\text{V}$, unless otherwise noted)

Symbol	Parameter	Limits						Unit	
		-7,-7L		-8,-8L		-10,-10L			
		Min.	Max.	Min.	Max.	Min.	Max.		
tAC	Access time from CK	CL=2		6		7		8	ns
		CL=3		6		6		8	ns
tOH	Output Hold time from CK	3		3		3		ns	
tOLZ	Delay time, output low impedance from CK	0		0		0		ns	
tOHZ	Delay time, output high impedance from CK	3	6	3	6	3	8	ns	

Note:3 If t_r (clock rising time) is longer than 1ns, $(t_r/2-0.5)\text{ns}$ should be added to parameter.

Output Load Condition

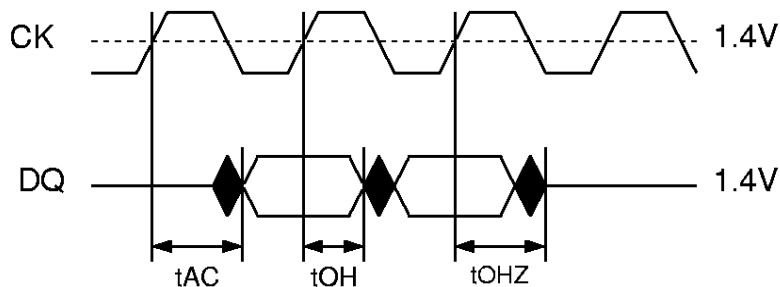
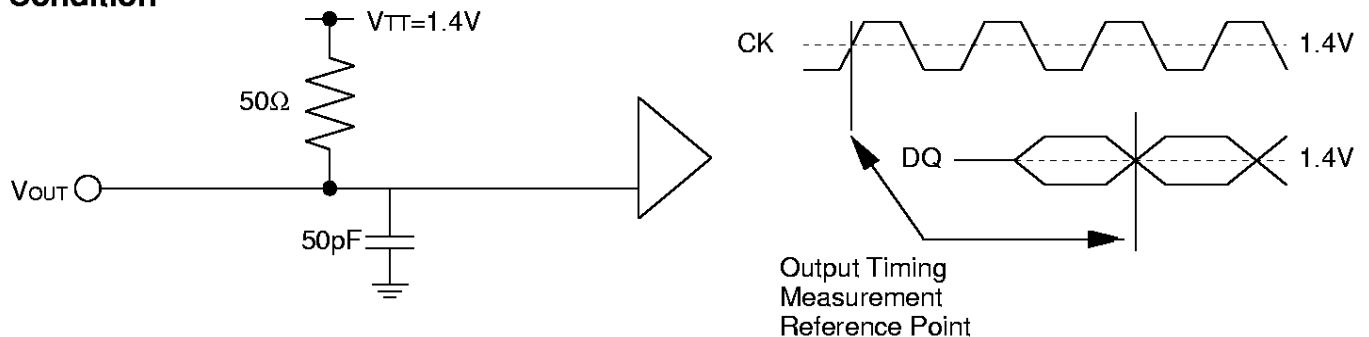

MH8S64QFC -7,-7L,-8,-8L,-10,-10L

536870912-BIT (8388608 - WORD BY 64-BIT) Synchronous DRAM

Burst Write (single bank) @BL=4

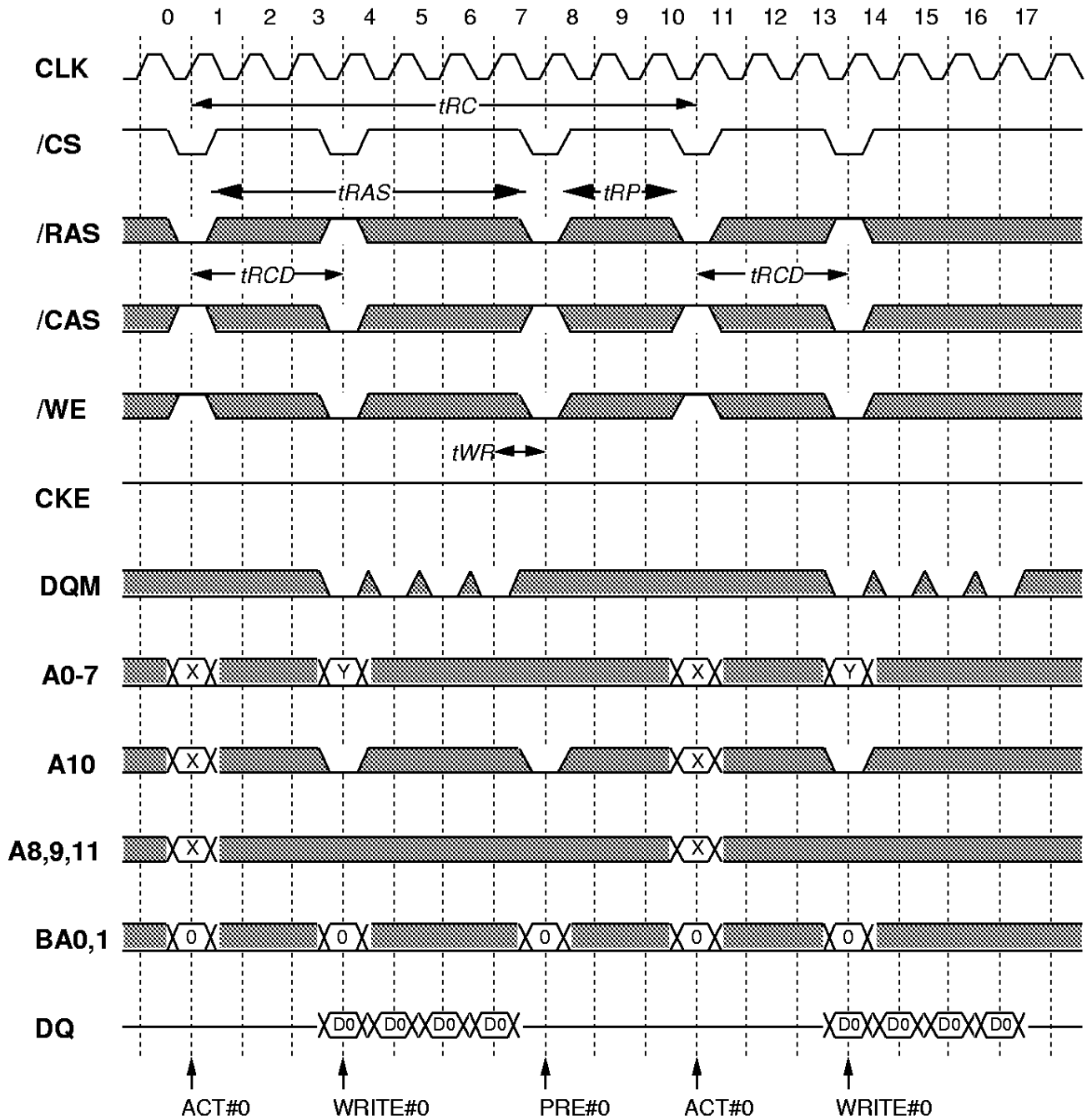

Italic parameter indicates minimum case

MH8S64QFC -7,-7L,-8,-8L,-10,-10L

536870912-BIT (8388608 - WORD BY 64-BIT) Synchronous DRAM

Burst Write (multi bank) @BL=4

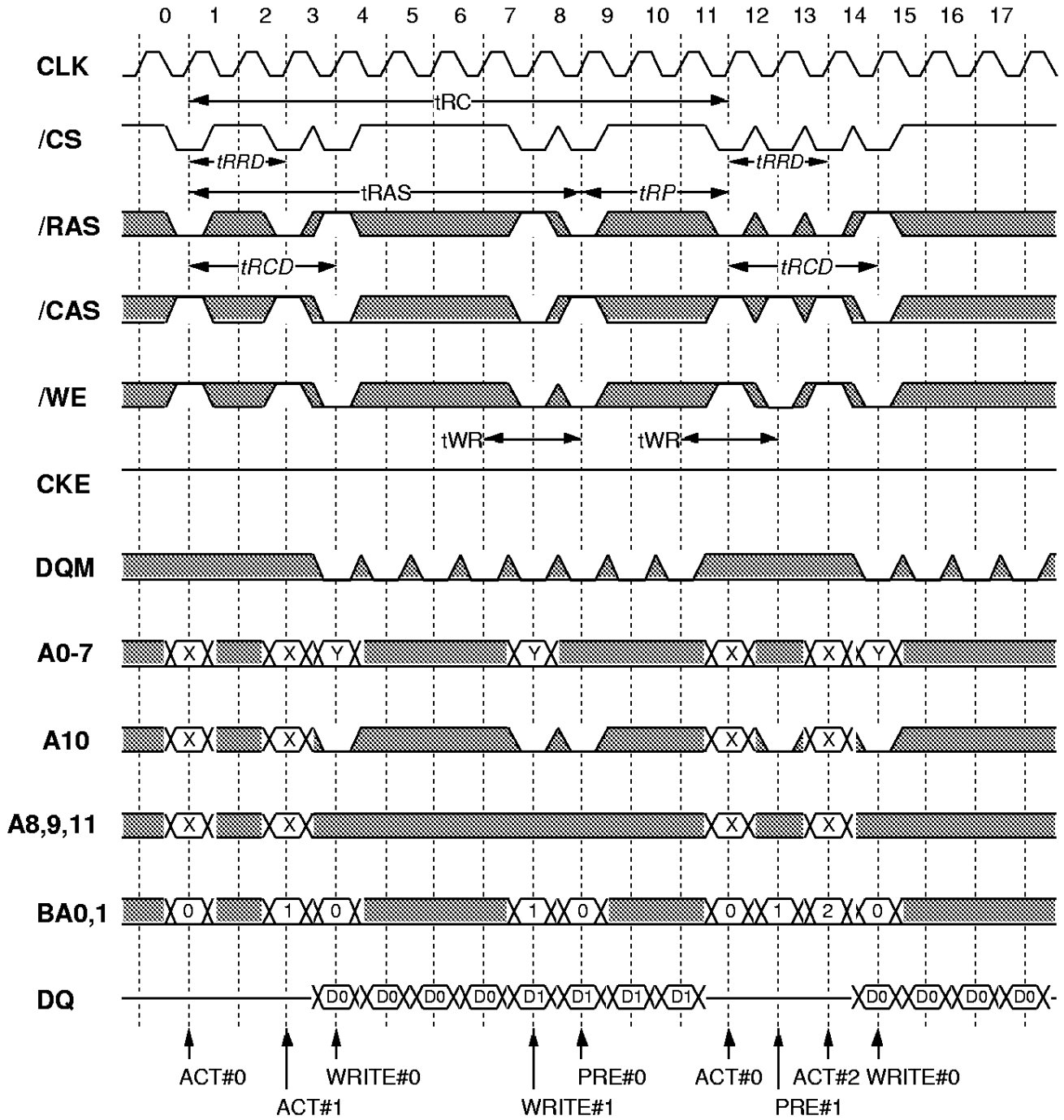

Italic parameter indicates minimum case

MH8S64QFC -7,-7L,-8,-8L,-10,-10L

536870912-BIT (8388608 - WORD BY 64-BIT) Synchronous DRAM

Burst Read (single bank) @BL=4 CL=3

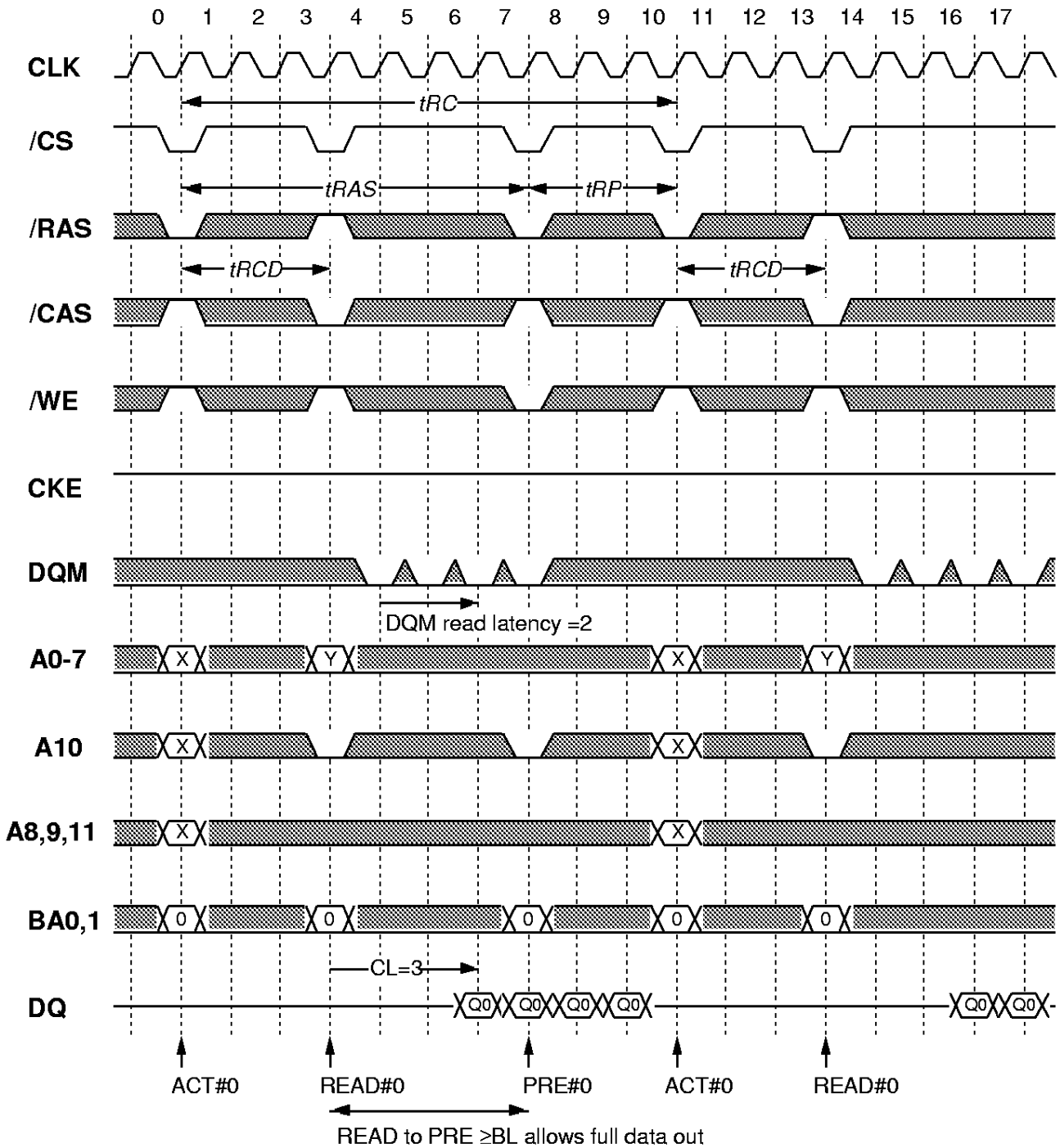

Italic parameter indicates minimum case

MH8S64QFC -7,-7L,-8,-8L,-10,-10L

536870912-BIT (8388608 - WORD BY 64-BIT) Synchronous DRAM

Burst Read (multiple bank) @BL=4 CL=3

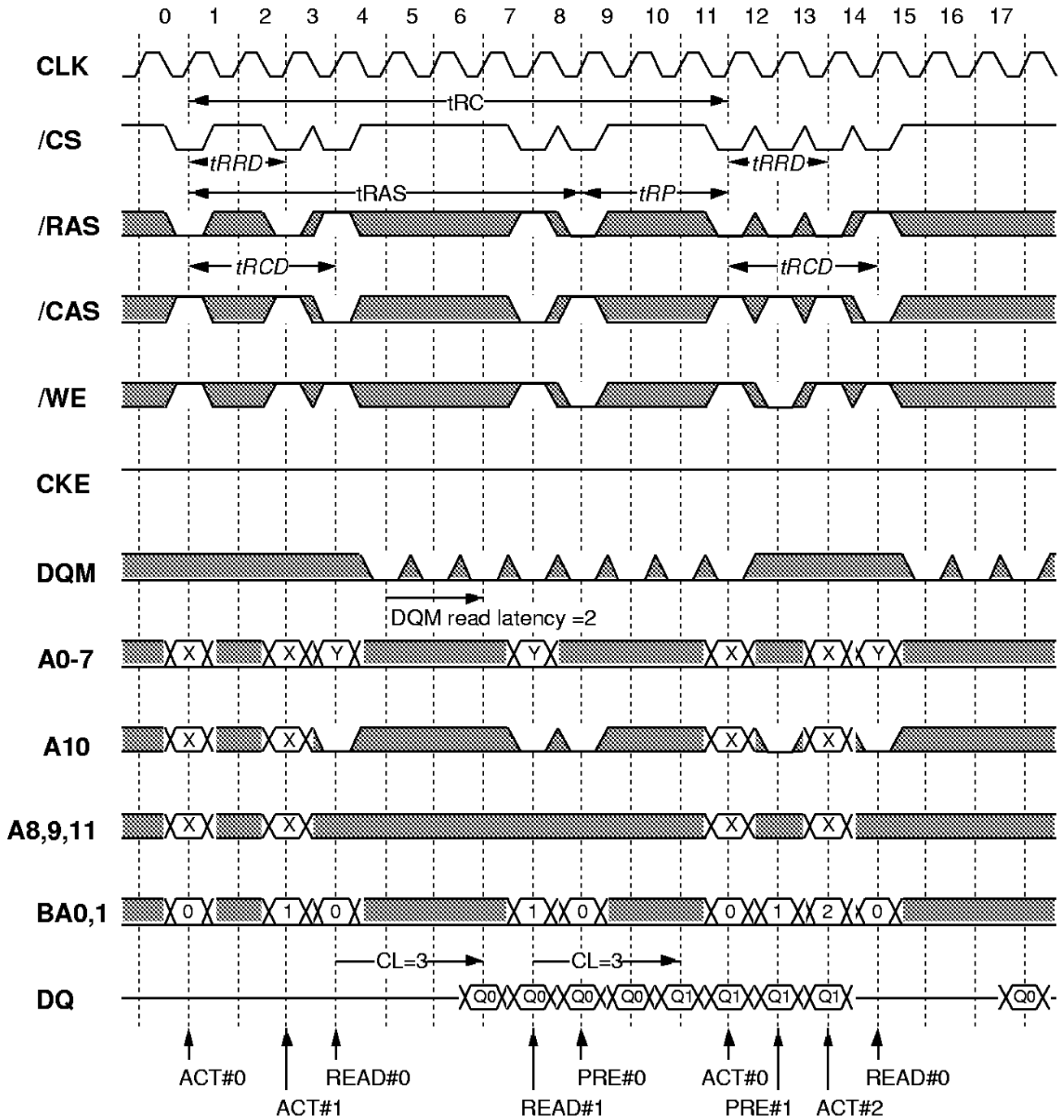

Italic parameter indicates minimum case

MH8S64QFC -7,-7L,-8,-8L,-10,-10L

536870912-BIT (8388608 - WORD BY 64-BIT) Synchronous DRAM

Burst Write (multi bank) with Auto-Precharge @BL=4

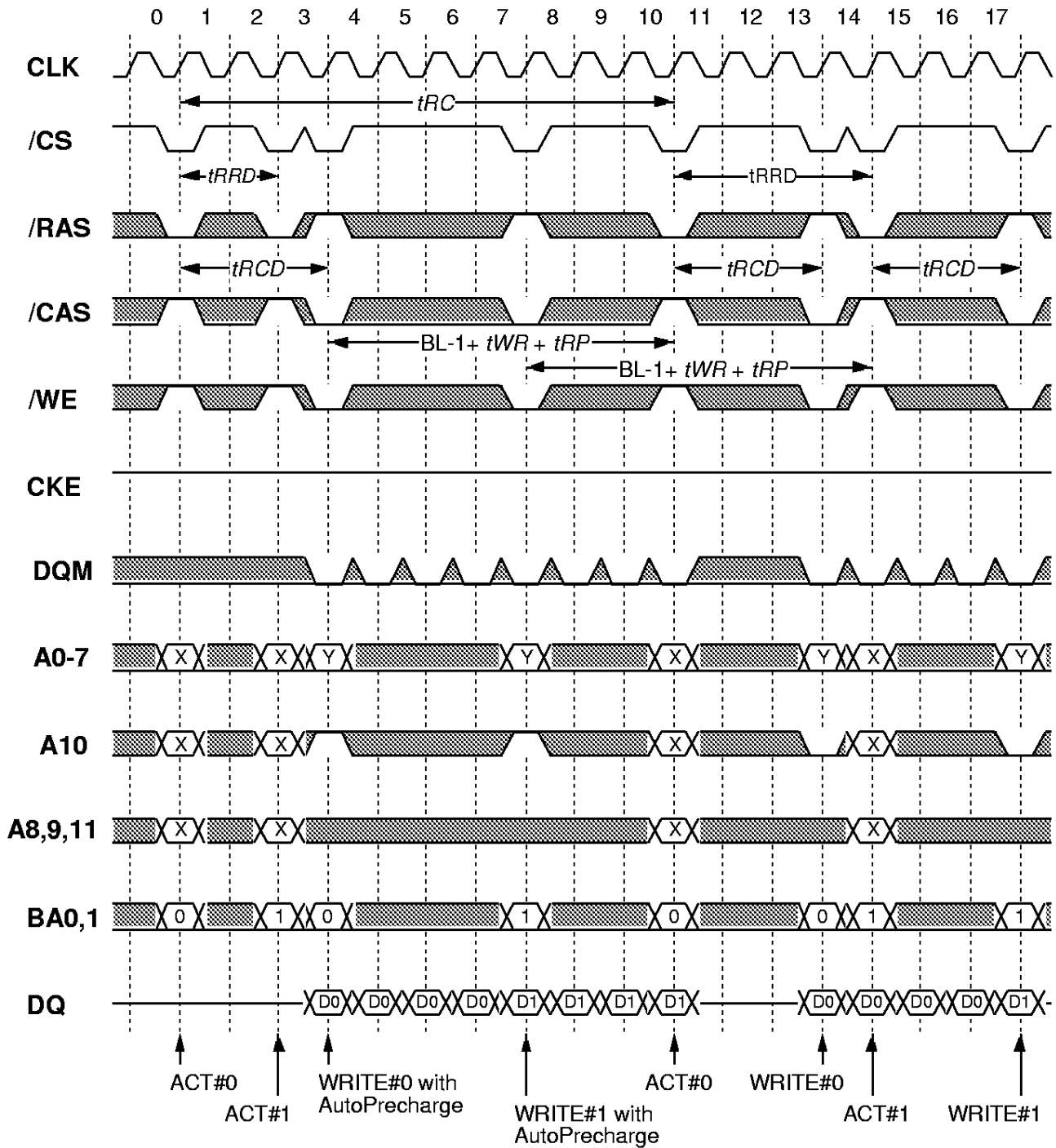

Italic parameter indicates minimum case

MH8S64QFC -7,-7L,-8,-8L,-10,-10L

536870912-BIT (8388608 - WORD BY 64-BIT) Synchronous DRAM

Burst Read (multiple bank) with Auto-Precharge @BL=4 CL=3

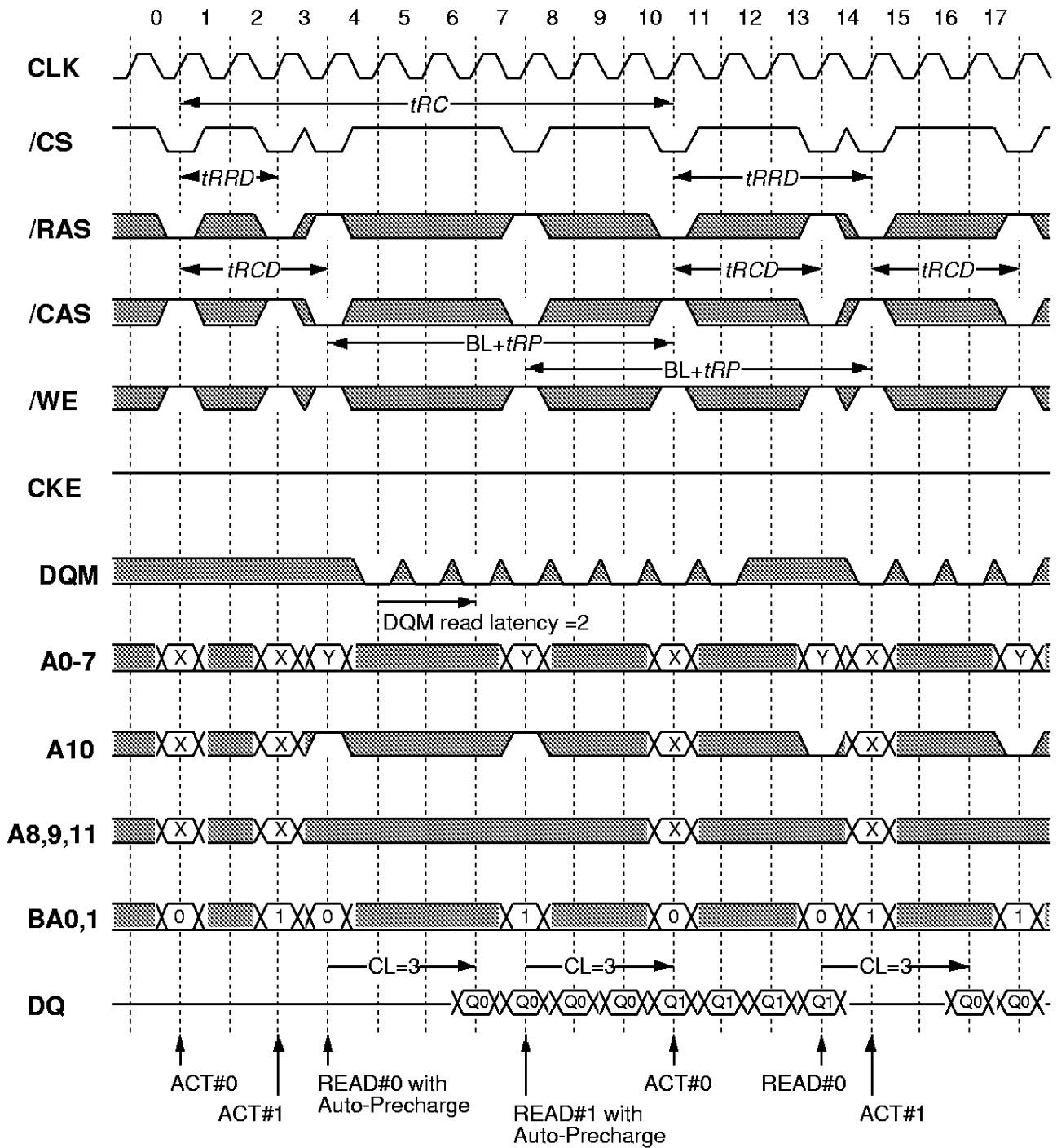

Italic parameter indicates minimum case

MH8S64QFC -7,-7L,-8,-8L,-10,-10L

536870912-BIT (8388608 - WORD BY 64-BIT) Synchronous DRAM

Page Mode Burst Write (multi bank) @BL=4

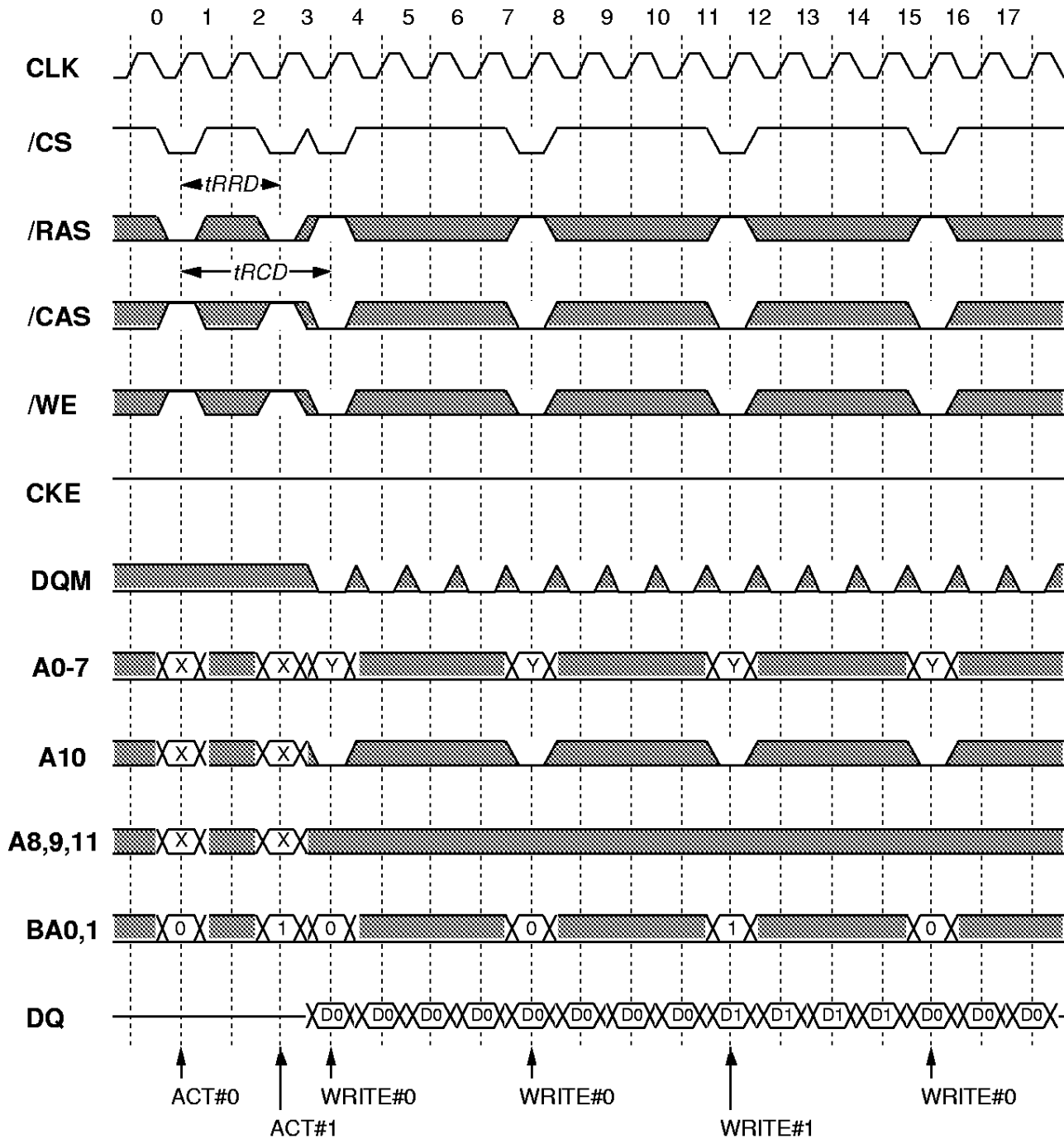

Italic parameter indicates minimum case

MH8S64QFC -7,-7L,-8,-8L,-10,-10L

536870912-BIT (8388608 - WORD BY 64-BIT) Synchronous DRAM

Page Mode Burst Read (multi bank) @BL=4 CL=3

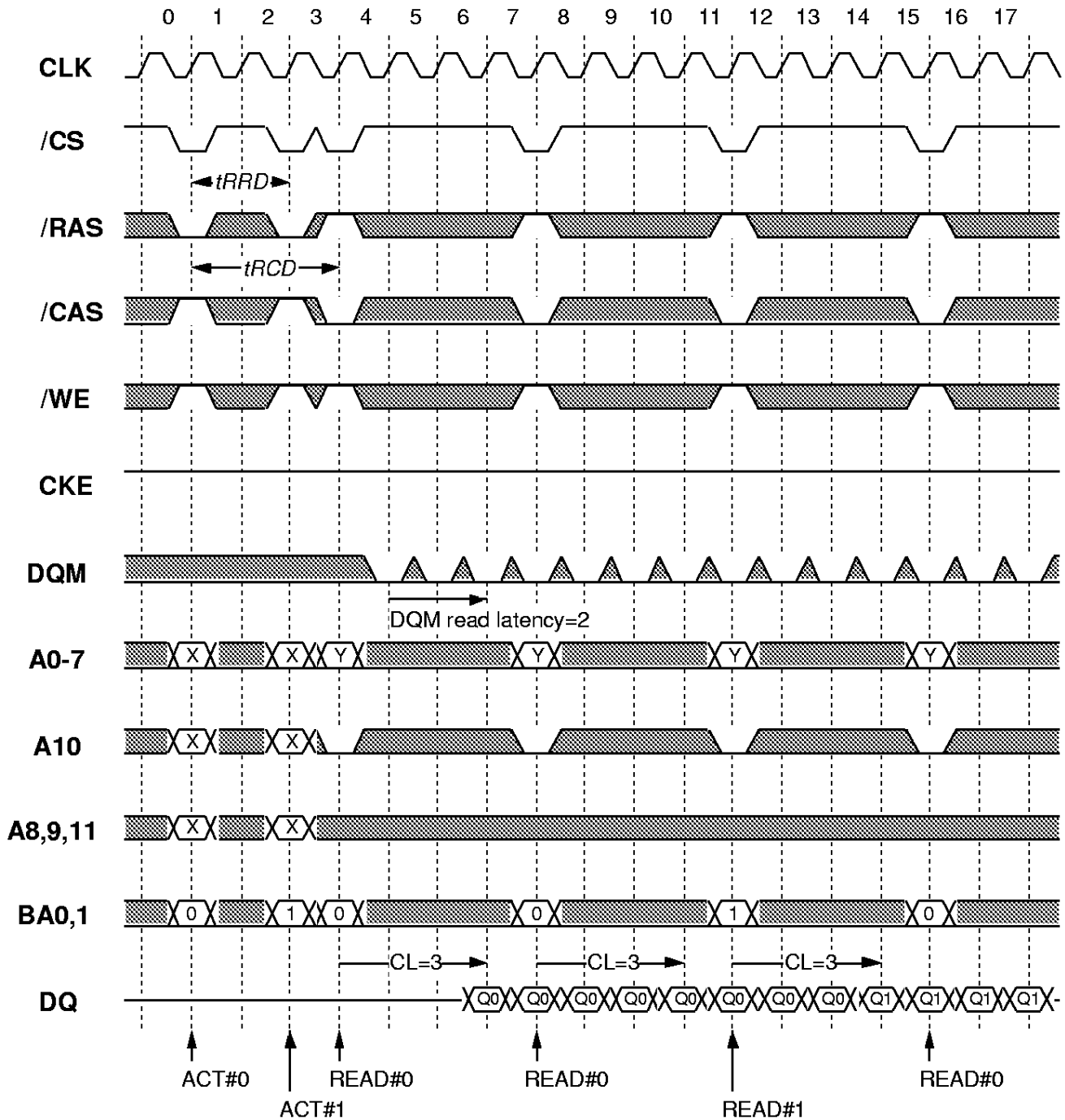

Italic parameter indicates minimum case

MH8S64QFC -7,-7L,-8,-8L,-10,-10L

536870912-BIT (8388608 - WORD BY 64-BIT) Synchronous DRAM

Write Interrupted by Write / Read @BL=4

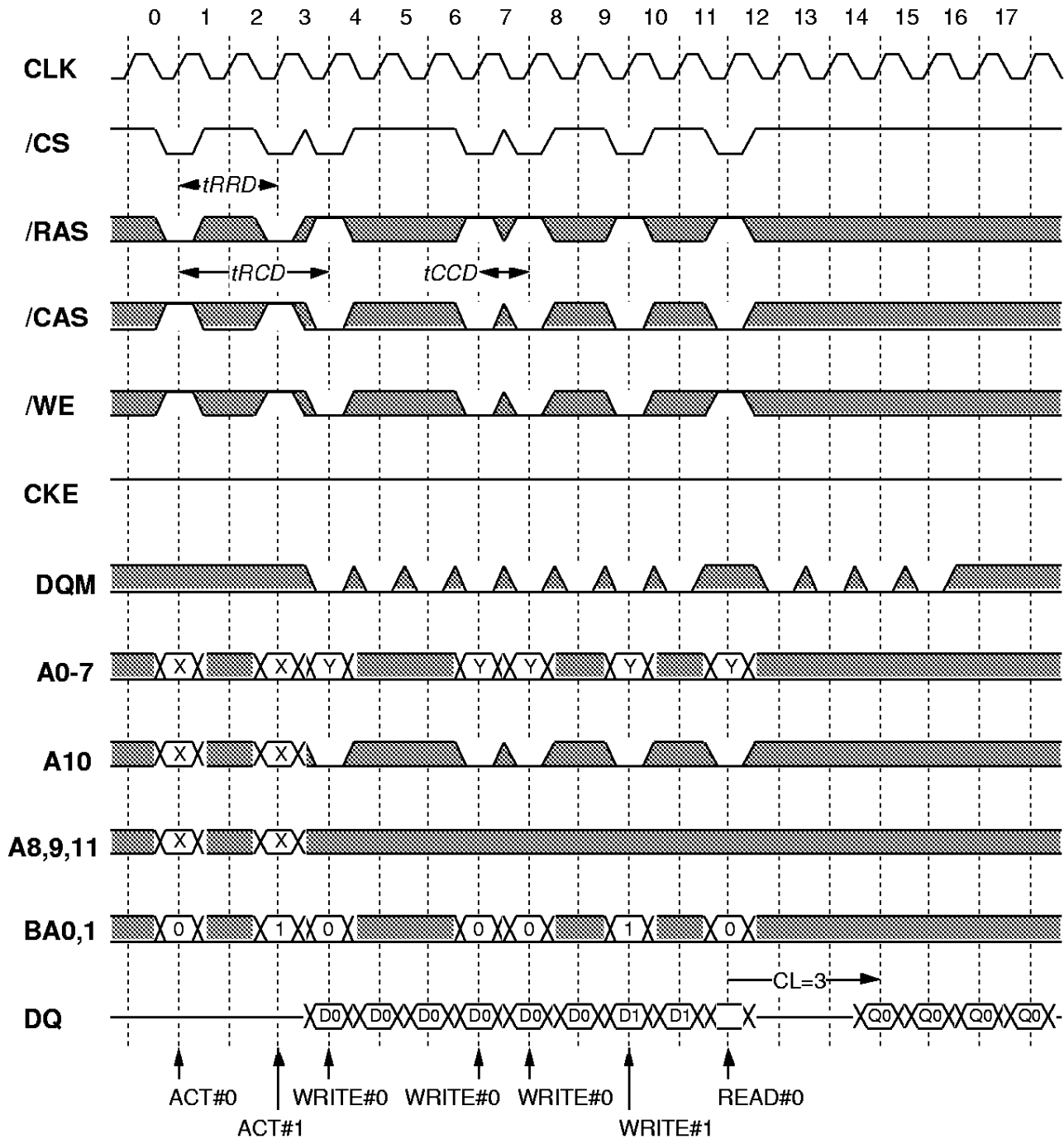

Burst Write can be interrupted by Write or Read of any active bank.

Italic parameter indicates minimum case

MH8S64QFC -7,-7L,-8,-8L,-10,-10L

536870912-BIT (8388608 - WORD BY 64-BIT) Synchronous DRAM

Read Interrupted by Read / Write @BL=4 CL=3

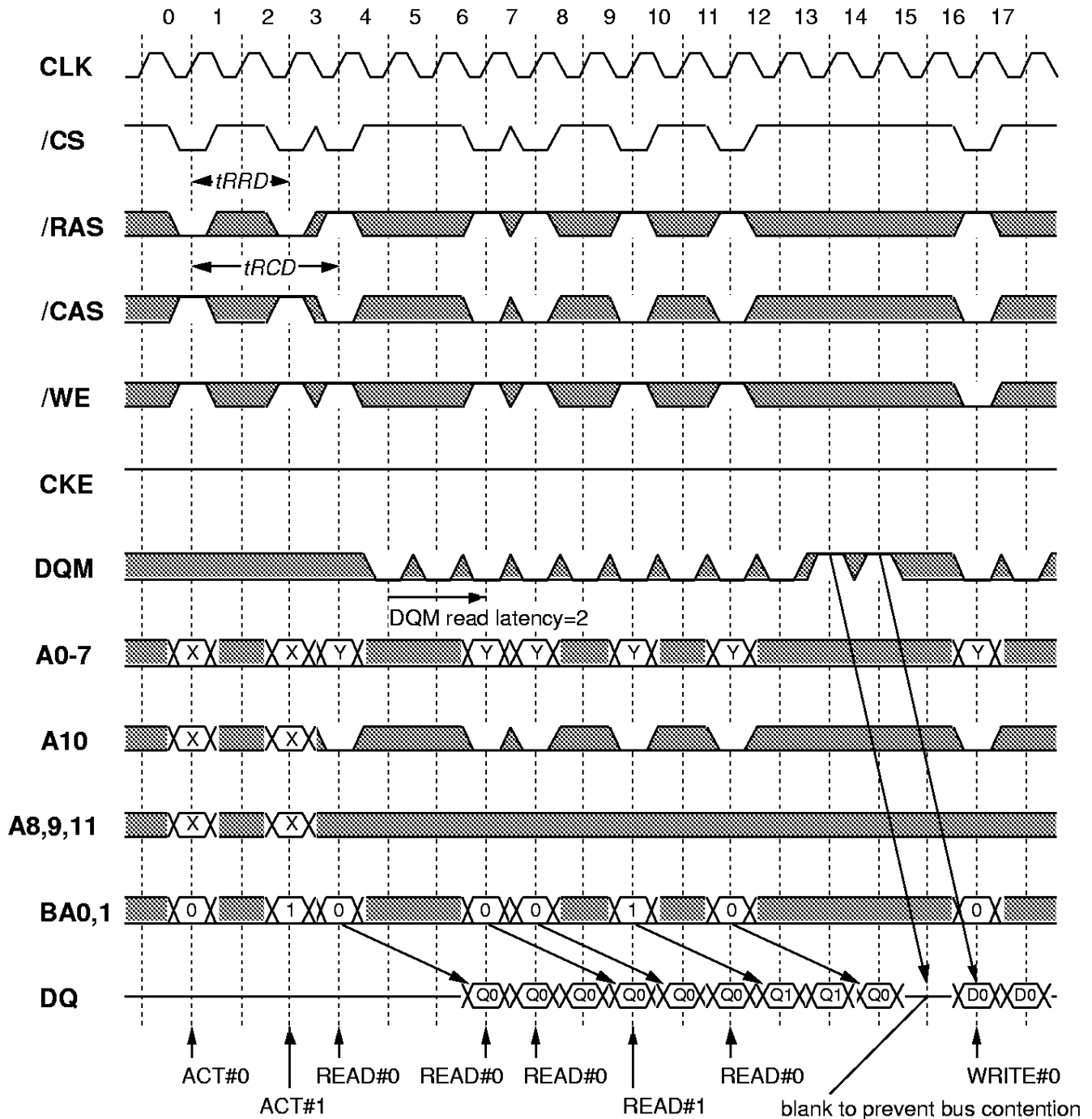

Burst Read can be interrupted by Read or Write of any active bank.

Italic parameter indicates minimum case

MH8S64QFC -7,-7L,-8,-8L,-10,-10L

536870912-BIT (8388608 - WORD BY 64-BIT) Synchronous DRAM

Write Interrupted by Precharge @BL=4

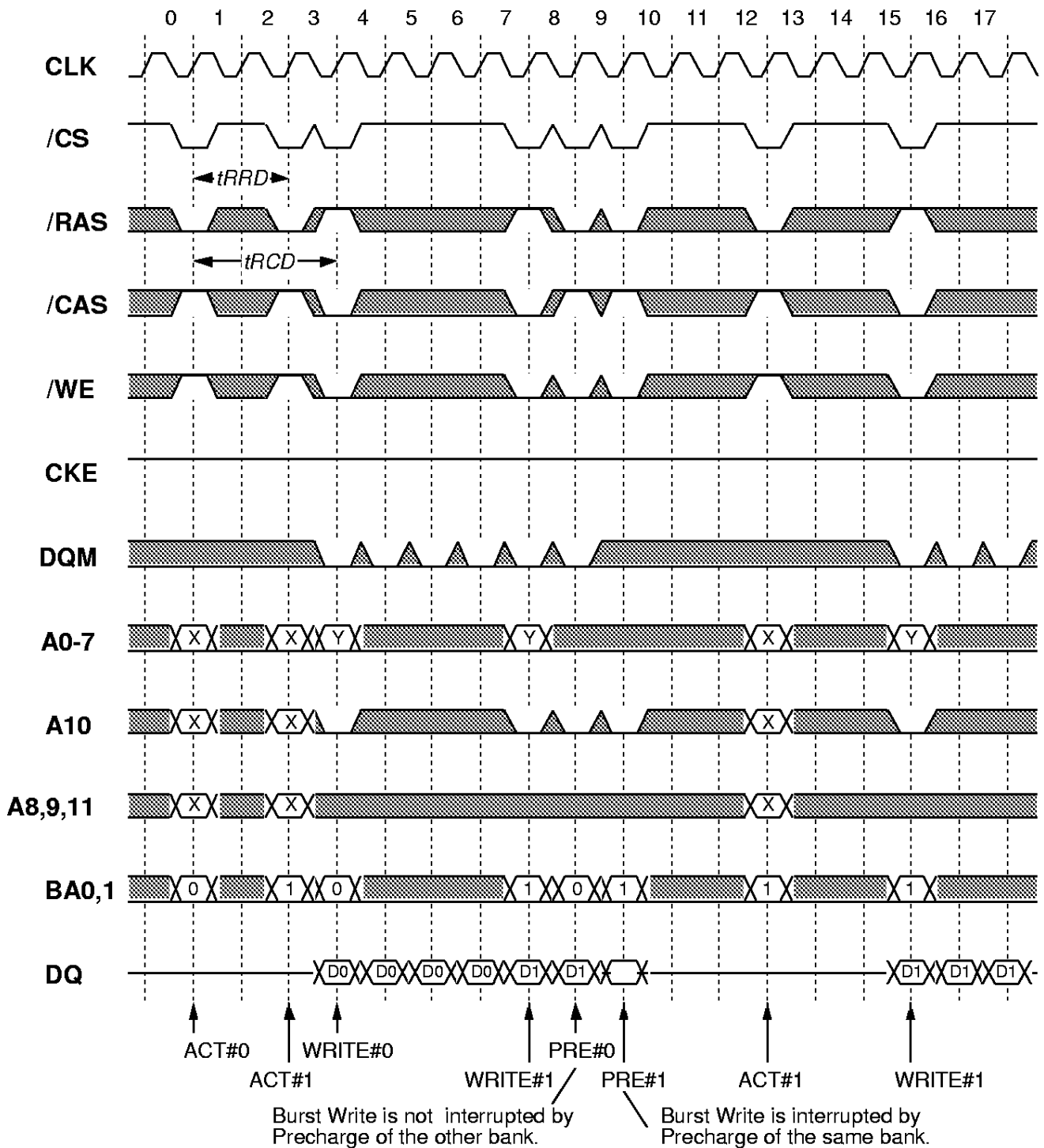

MH8S64QFC -7,-7L,-8,-8L,-10,-10L

536870912-BIT (8388608 - WORD BY 64-BIT) Synchronous DRAM

Read Interrupted by Precharge @BL=4 CL=3

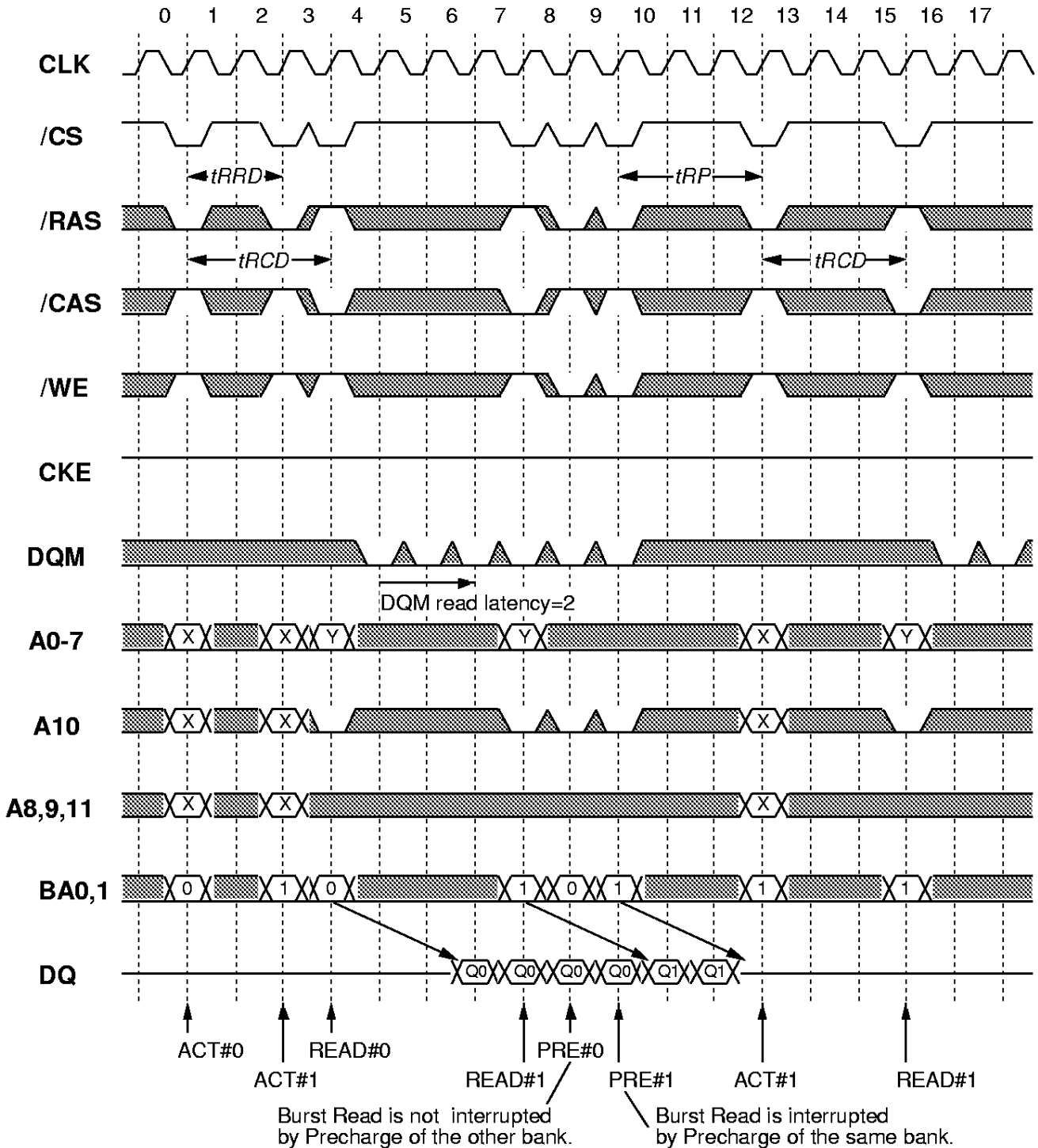

Italic parameter indicates minimum case

MH8S64QFC -7,-7L,-8,-8L,-10,-10L

536870912-BIT (8388608 - WORD BY 64-BIT) Synchronous DRAM

Mode Register Setting

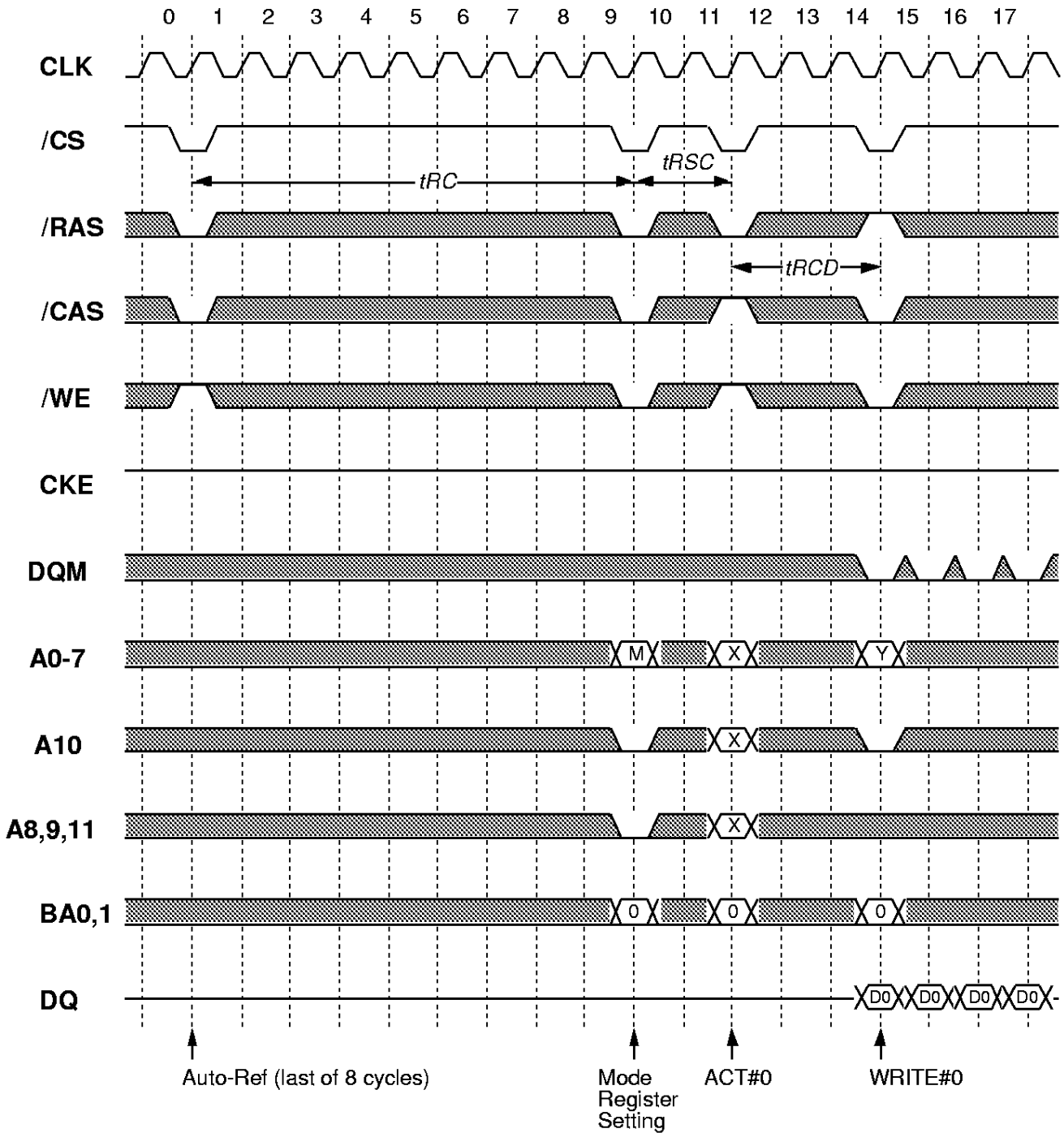

Italic parameter indicates minimum case

MH8S64QFC -7,-7L,-8,-8L,-10,-10L

536870912-BIT (8388608 - WORD BY 64-BIT) Synchronous DRAM

Auto-Refresh @BL=4

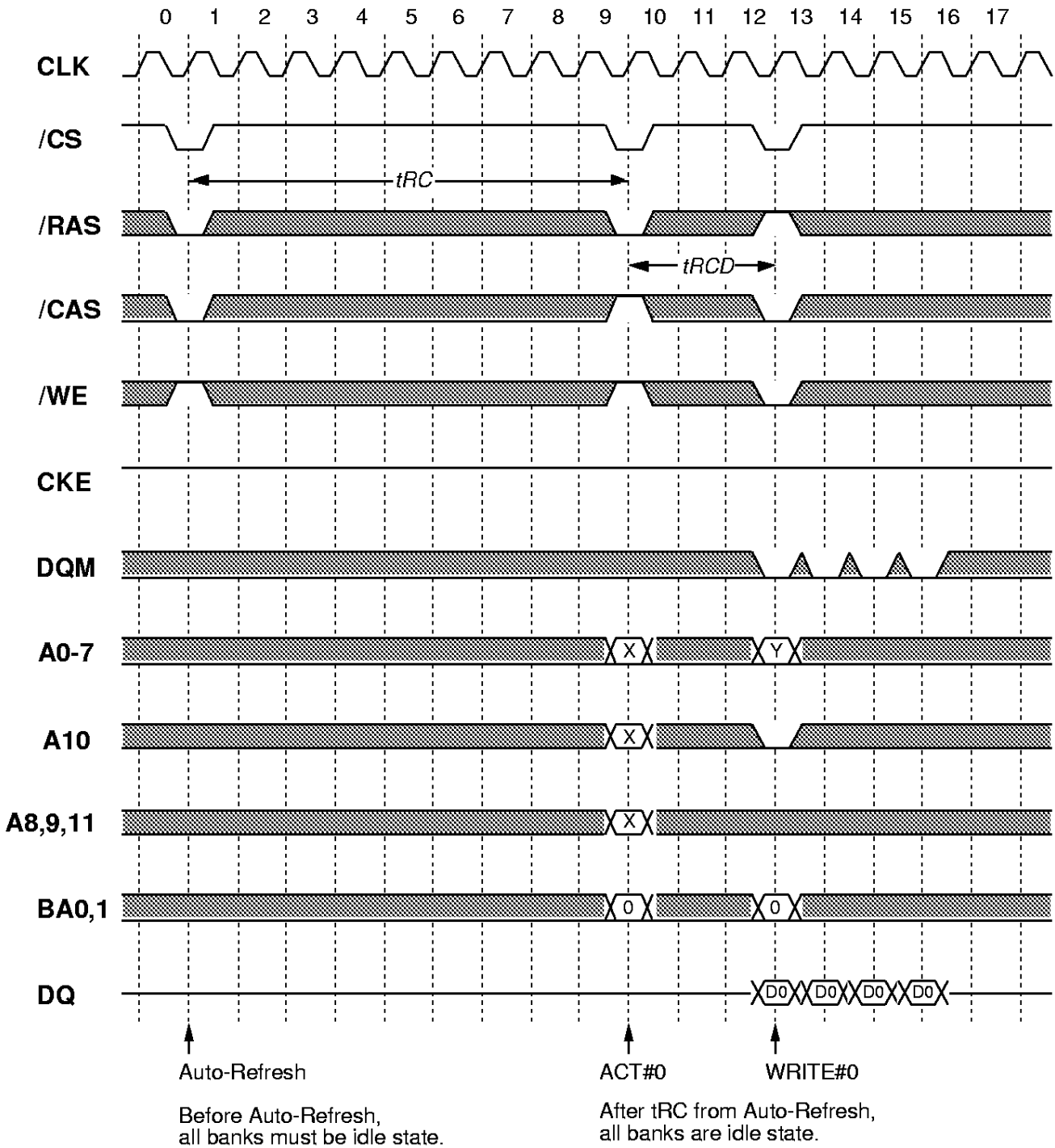

Italic parameter indicates minimum case

Self-Refresh

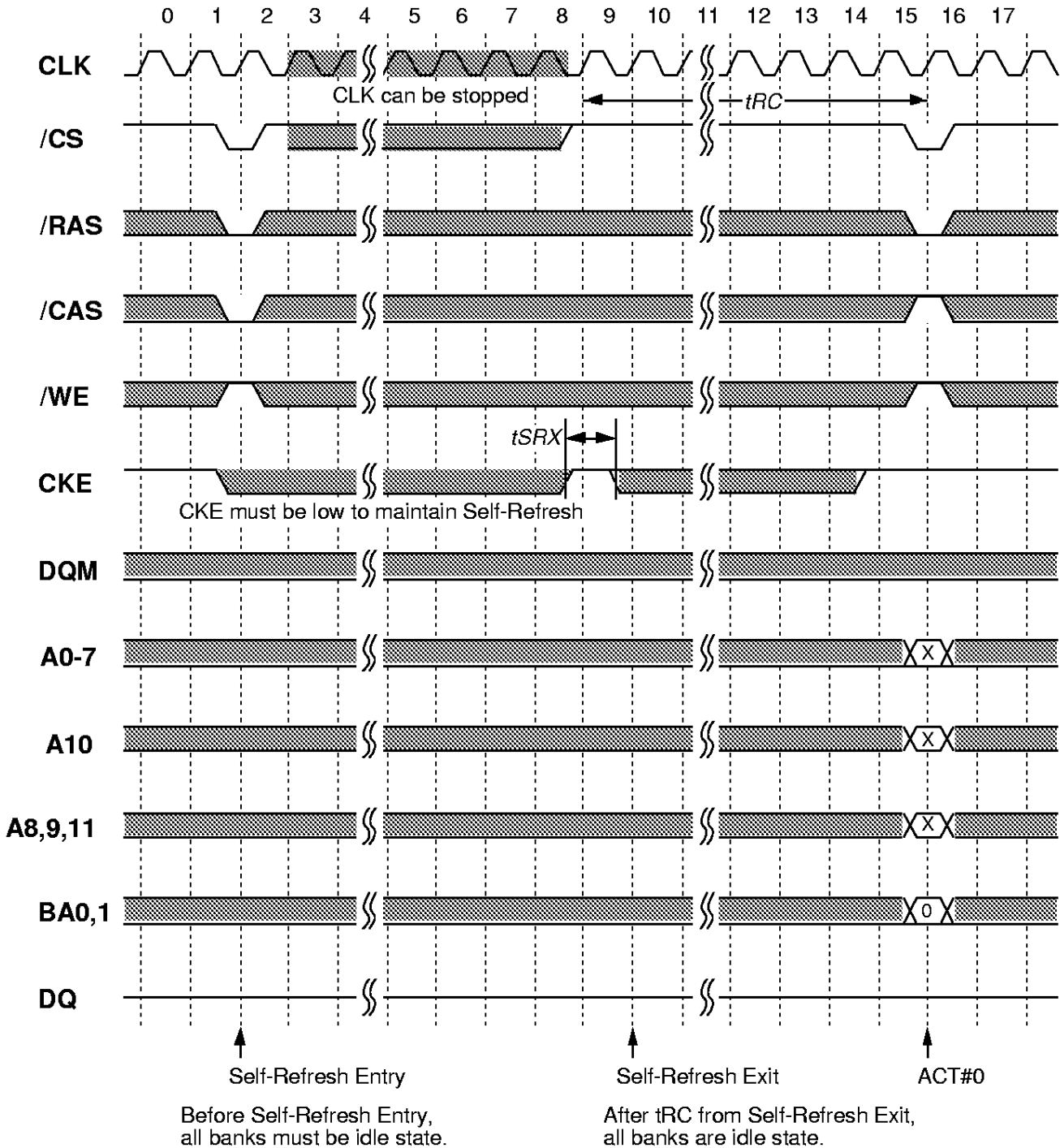

Italic parameter indicates minimum case

MH8S64QFC -7,-7L,-8,-8L,-10,-10L

536870912-BIT (8388608 - WORD BY 64-BIT) Synchronous DRAM

DQM Write Mask @BL=4

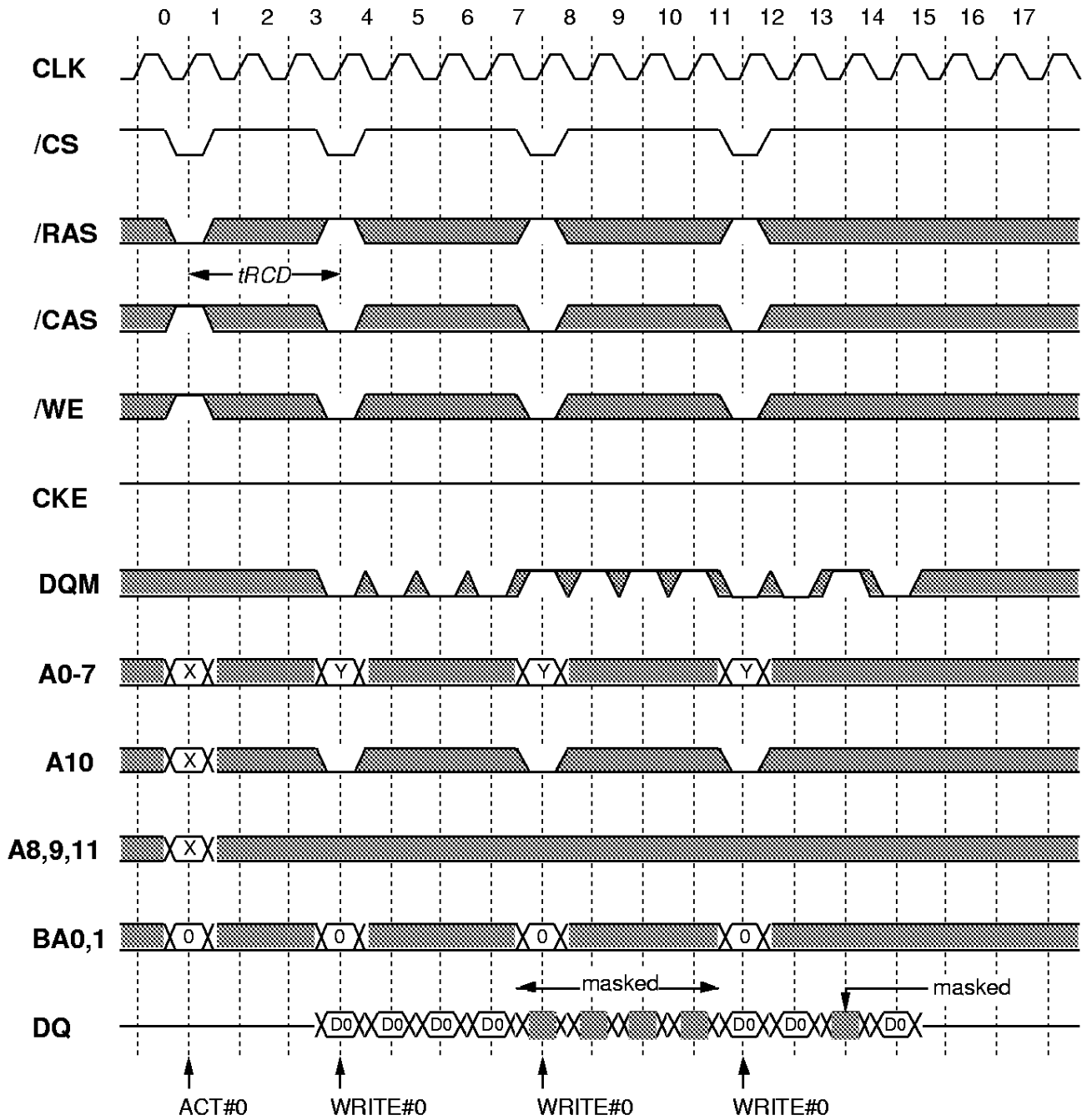

Italic parameter indicates minimum case

MH8S64QFC -7,-7L,-8,-8L,-10,-10L

536870912-BIT (8388608 - WORD BY 64-BIT) Synchronous DRAM

DQM Read Mask @BL=4 CL=3

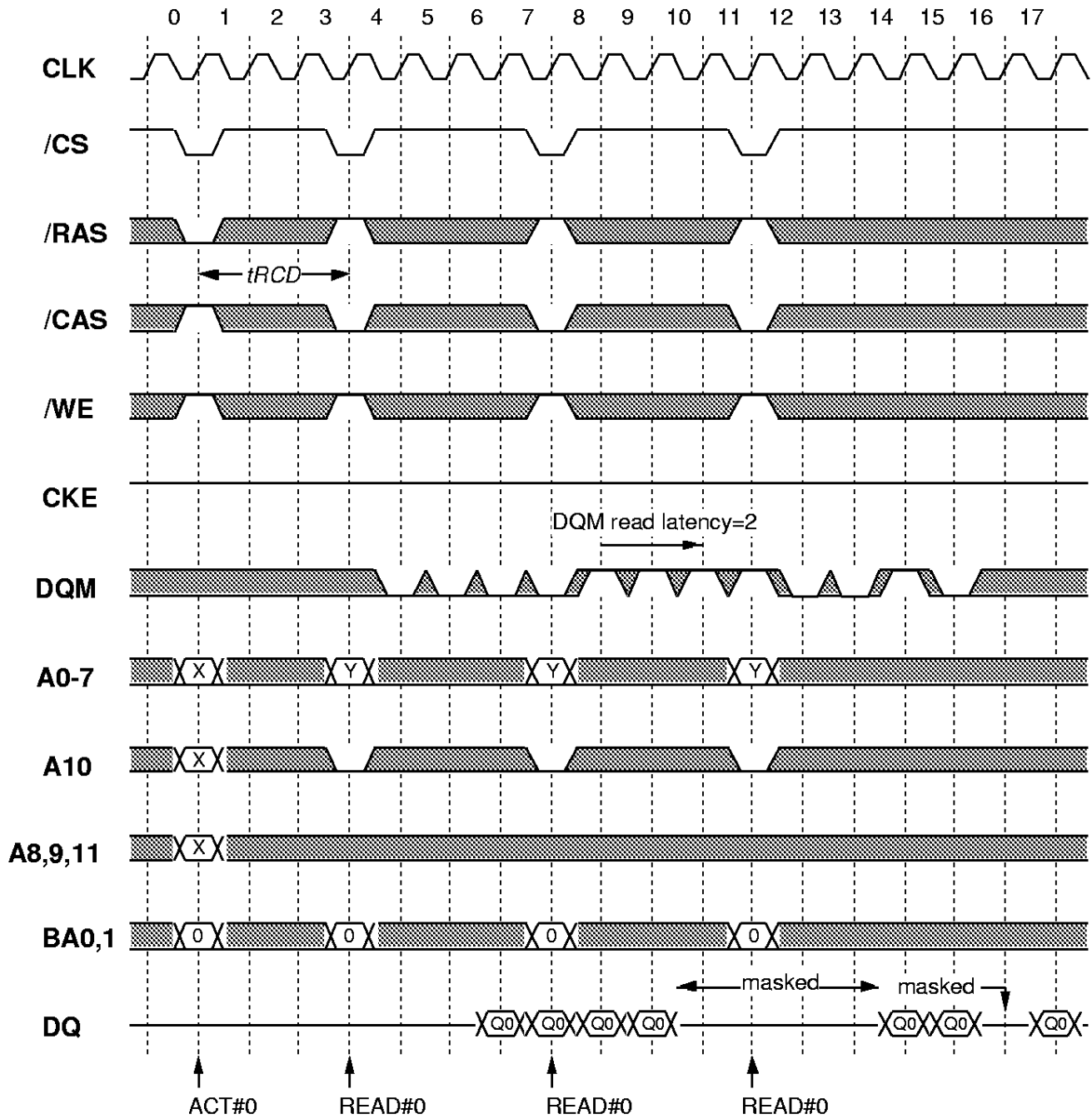

Italic parameter indicates minimum case

MH8S64QFC -7,-7L,-8,-8L,-10,-10L

536870912-BIT (8388608 - WORD BY 64-BIT) Synchronous DRAM

Power Down

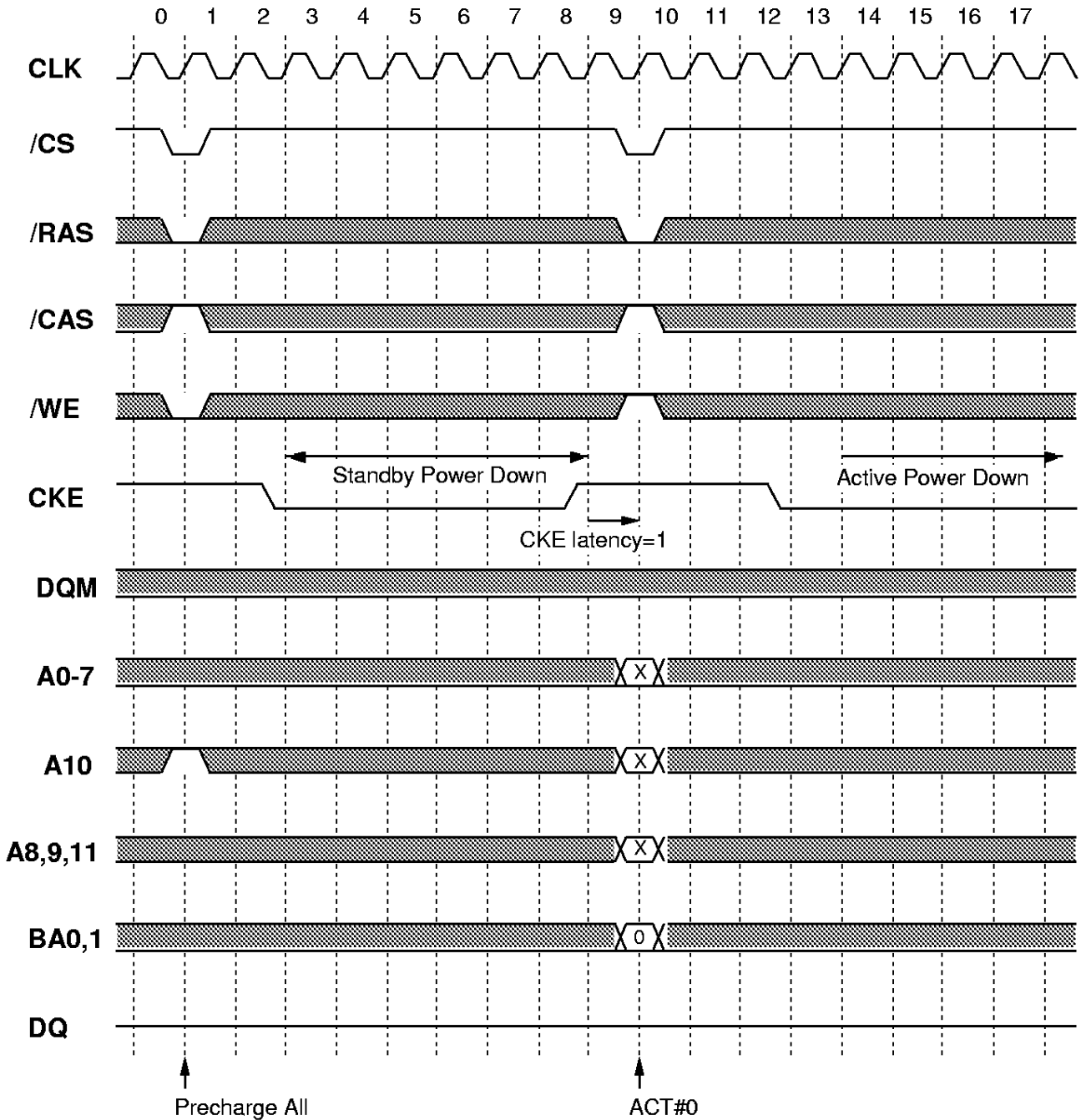

Italic parameter indicates minimum case

MH8S64QFC -7,-7L,-8,-8L,-10,-10L

536870912-BIT (8388608 - WORD BY 64-BIT) Synchronous DRAM

CLK Suspend @BL=4 CL=3

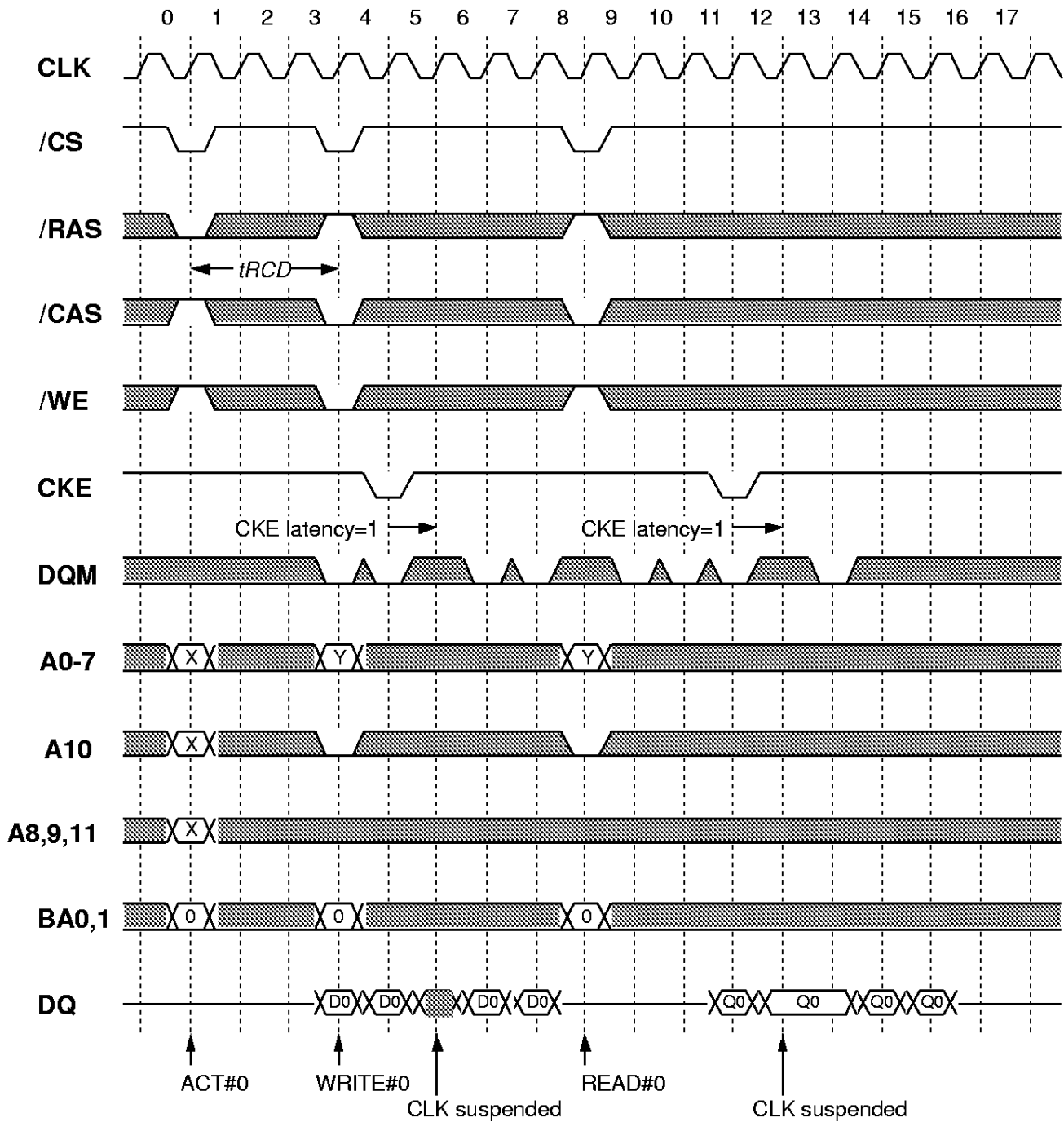

Italic parameter indicates minimum case

MH8S64QFC -7,-7L,-8,-8L,-10,-10L

536870912-BIT (8388608 - WORD BY 64-BIT) Synchronous DRAM

OUTLINE

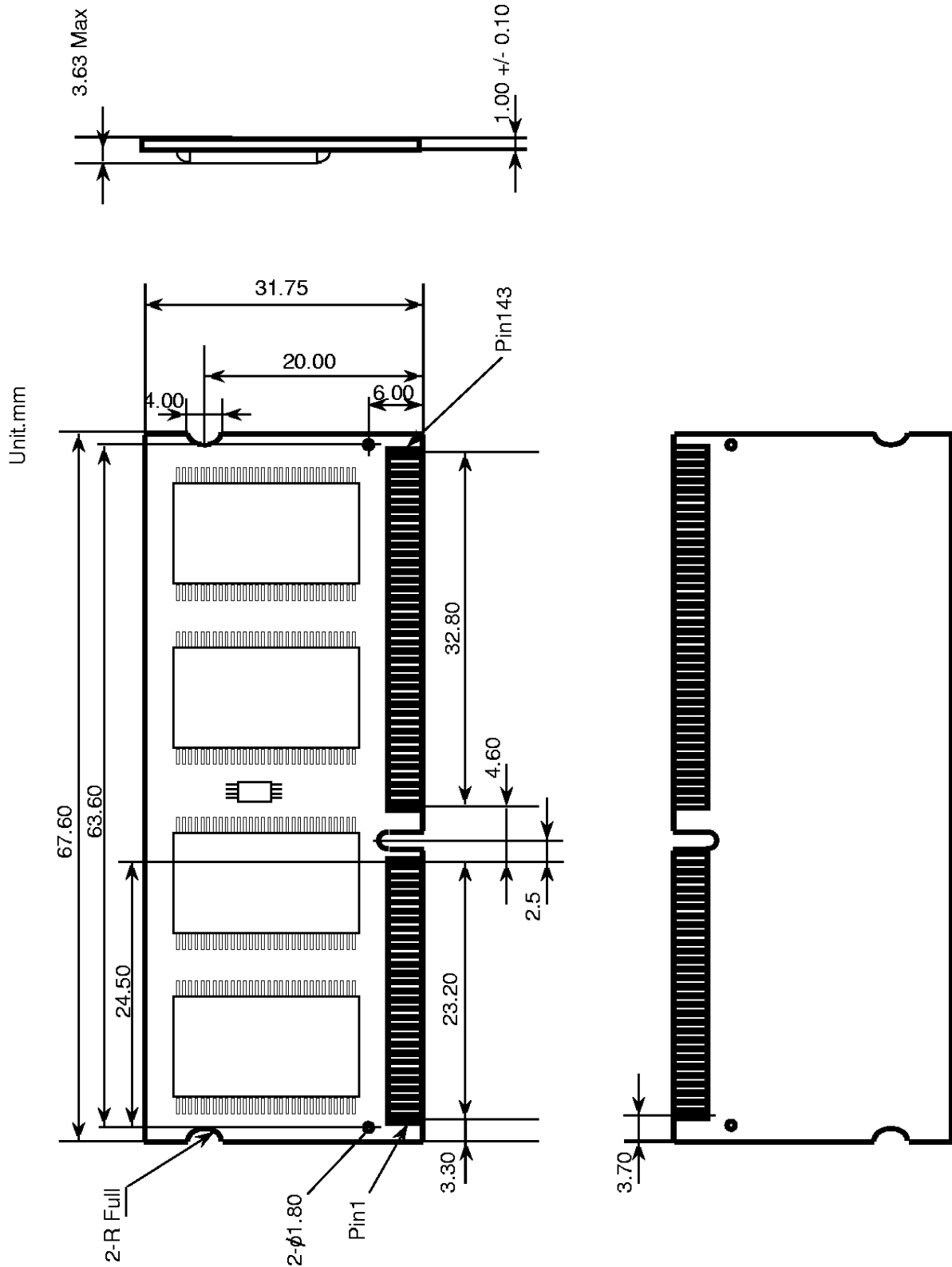

Keep safety first in your circuit designs!

Mitsubishi Electric Corporation puts the maximum effort into making semiconductor products better and more reliable, but there is always the possibility that trouble may occur with them. Trouble with semiconductors consideration to safety when making your circuit designs, with appropriate measures such as (i) placement of substitutive, auxiliary circuits, (ii) use of non-flammable material or (iii) prevention against any malfunction or mishap.

Notes regarding these materials

1. These materials are intended as a reference to assist our customers in the selection of the Mitsubishi semiconductor product best suited to the customer's application; they do not convey any license under any intellectual property rights, or any other rights, belonging to Mitsubishi Electric Corporation or a third party.
2. Mitsubishi Electric Corporation assumes no responsibility for any damage, or infringement of any third-party's rights, originating in the use of any product data, diagrams, charts or circuit application examples contained in these materials.
3. All information contained in these materials, including product data, diagrams and charts, represent information on products at the time of publication of these materials, and are subject to change by Mitsubishi Electric Corporation without notice due to product improvements or other reasons. It is therefore recommended that customers contact Mitsubishi Electric Corporation or an authorized Mitsubishi Semiconductor product distributor for the latest product information before purchasing a product listed herein.
4. Mitsubishi Electric Corporation semiconductors are not designed or manufactured for use in a device or system that is used under circumstances in which human life is potentially at stake. Please contact Mitsubishi Electric Corporation or an authorized Mitsubishi Semiconductor product distributor when considering the use of a product contained herein for special applications, such as apparatus or systems for transportation, vehicular, medical, aerospace, nuclear, or undersea repeater use.
5. The prior written approval of Mitsubishi Electric Corporation is necessary to reprint or reproduce in whole or in part these materials.
6. If these products or technologies are subject to the Japanese export control restrictions, they must be exported under a license from the Japanese government and cannot be imported into a country other than the approved destination.
Any diversion or reexport contrary to the export control laws and regulations of Japan and/or the country of destination is prohibited.
7. Please contact Mitsubishi Electric Corporation or an authorized Mitsubishi Semiconductor product distributor for further details on these materials or the products contained therein.