

FEATURES

Dual Channel
98 dB Signal-to-Noise Ratio
98 dB THD+N
0.0004 dB Passband Ripple
115 dB Stopband Attenuation
64× Oversampling
Linear Phase

APPLICATIONS

DAT and DCC Tape Players
Direct-to-Disc Recorders
Digital Audio Editors
Digital Mixing Consoles

PRODUCT DESCRIPTION

The AD1878 is a two-channel, 16-bit oversampled digital audio ADC. Each channel incorporates a high performance one-bit noise shaping modulator and a digital decimating filter. An on-board voltage reference is also included. ADC output data is transmitted from a flexible serial data port. The circuitry of the AD1878 is segmented between two monolithic chips.

The voltage reference and one-bit modulators are fabricated on a BiCMOS chip. The reference circuitry provides a reference voltage that is stable over temperature and time. Using an external master clock, the one-bit modulators operate at a $64 \times F_s$ oversampling ratio. This oversampling ratio permits the antialias filters to be simple resistor-capacitor combinations and results in linear phase throughout the passband. The modulators are 5th order and employ differential switched capacitor filters to provide the required noise shaping characteristics and extremely low distortion.

The digital decimating filters and serial port are fabricated using a CMOS process. Using a proprietary technique, these single-stage digital filters provide a narrow transition band, deep stopband attenuation and low passband ripple.

The output port provides a single, serial bit stream which can operate in several MASTER or SLAVE modes. It is controlled by a clock and mode select pins. The format of the data is twos complement, MSB first. The output signals are TTL and 5 volt CMOS compatible. Output words may be transmitted in a right justified, I²S or user-defined format.

FUNCTIONAL BLOCK DIAGRAM

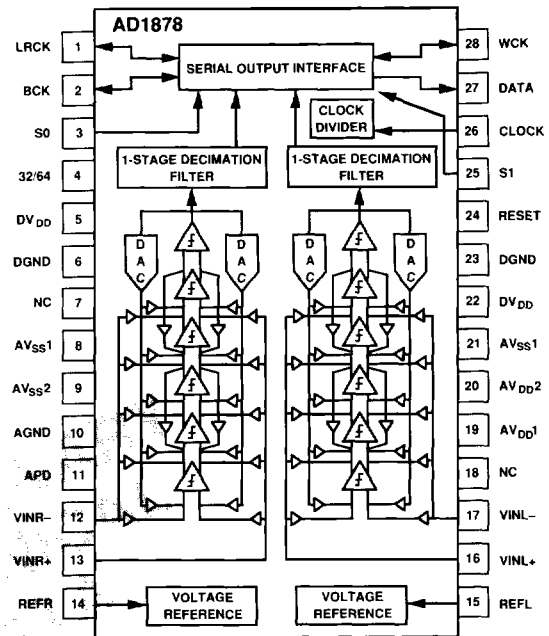

The AD1878 operates with ± 5 volt power supplies. Separate digital and analog power supplies and ground connections are provided for reduced digital crosstalk. The AD1878 is guaranteed to operate over a temperature range of -25°C to $+70^\circ\text{C}$ and is packaged in a 28-pin plastic DIP.

PRODUCT HIGHLIGHTS

1. $64 \times F_s$ sampling rate.
2. From 2.5 kHz to 50 kHz output word rates.
3. Passband ripple is less than 0.001 dB.
4. Stopband attenuation is 115 dB.
5. Excellent low level signal performance is achieved.
6. No sample-and-hold circuits are required.

This information applies to a product under development. Its characteristics and specifications are subject to change without notice. Analog Devices assumes no obligation regarding future manufacture unless otherwise agreed to in writing.

AD1878—SPECIFICATIONS

@ ± 5 volt Supplies, $T_A = +25^\circ\text{C}$, Clock = 12.288 MHz

Parameter	Target	Units
RESOLUTION	18	Bits
OVERSAMPLING RATIO	64	$\times F_s$
DYNAMIC RANGE, 0 kHz to 20 kHz, No A-Weight Filter		
Stereo Mode ¹	98	dB
Mono Mode ²	101	dB
SIGNAL TO (NOISE + DISTORTION)		
0 dB, 1 kHz	98	dB
-20 dB, 1 kHz	85	dB
-60 dB, 1 kHz	45	dB
ANALOG INPUTS		
Input Range	±3	V
Input Impedance	12.8	k Ω
REFERENCE OUTPUT		
Output Voltage	3	V
Output Impedance	TBD	
DC ACCURACY		
Gain Matching	TBD	dB
Gain Error	TBD	%
Gain Drift	TBD	ppm/ $^\circ\text{C}$
Midscale Error	20	LSBs
Midscale Drift	TBD	ppm/ $^\circ\text{C}$
PHASE DEVIATION (Interchannel)	Below Measurable Limit	Degrees
CROSSTALK		
20 kHz, EIAJ Method	105	dB
DIGITAL FILTER CHARACTERISTICS		
Passband Ripple	0.001	dB
Stopband Attenuation	115	dB
12.288 MHz Master Clock ⁴		
Passband Edge	21.7	kHz
Stopband Edge	26.2	kHz
11.2896 MHz Clock ⁵		
Passband Edge	20	kHz
Stopband Edge	24.1	kHz
DIGITAL INPUTS AND OUTPUTS		
V_{IH}	2.0	V
V_{IL}	0.8	V
I_{IH} @ $V_{IH} = 5\text{ V}$	10	μA
I_{IL} @ $V_{IL} = 0\text{ V}$	10	μA
V_{OH} @ $I_{OH} = 4\text{ mA}$	4.5	V
V_{OL} @ $I_{OL} = 4\text{ mA}$	0.5	V
NOMINAL MASTER CLOCK FREQUENCY	12.288	MHz
POWER SUPPLIES		
Voltage, $+V_L$ and $+V_S$	5	V
Voltage, $-V_L$ and $-V_S$	-5	V
Current, $+I_L$ and $+I_S$	TBD	mA
Current, $-I_L$ and $-I_S$	TBD	mA
POWER DISSIPATION		
Operation	900	mW
Power Down APD = "1"	400	mW
POWER SUPPLY REJECTION RATIO	67	dB
TEMPERATURE RANGE		
Specification	25	$^\circ\text{C}$
Operation	-25 to +70	$^\circ\text{C}$
Storage	-60 to +100	$^\circ\text{C}$

NOTES

¹Stereo Mode uses output of each channel independently.

²Mono Mode sums output words to derive higher Dynamic Range.

³16-bit LSBs.

⁴Master Clock Frequency for 48 kHz sample rate.

⁵Master Clock Frequency for 44.1 kHz sample rate.

Specifications subject to change without notice.

This information applies to a product under development. Its characteristics and specifications are subject to change without notice. Analog Devices assumes no obligation regarding future manufacture unless otherwise agreed to in writing.