

SFP Copper Transceiver 10/100 BroadR-Reach™
SFP-1GBT-01

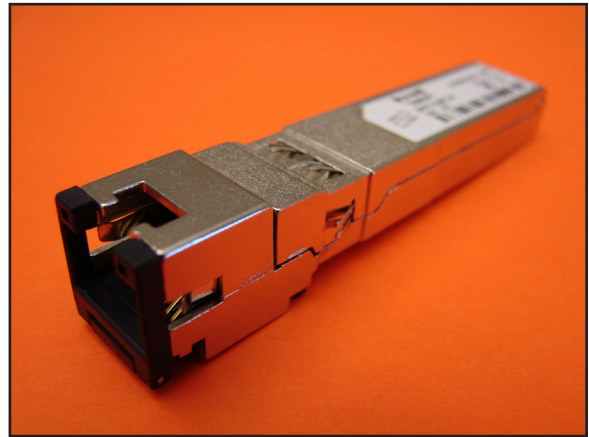

FEATURES / BENEFITS

- Design based on Broadcom’s BroadR-Reach™ technology, using their BCM54810S IC (login at <https://support.broadcom.com/Core/Login.aspx> for IC support)
- Complies with IEEE 802.3ab and Multi-Source Agreement (MSA) specifications for SFP transceivers
- Supports IEEE 802.3u and IEEE 802.3ab auto–negotiation features to allow networking equipment to automatically determine and adjust the required settings
- Automatically compensates for baseline wander by removing the DC offset from the input signal
- Low EMI emissions
- Automatic dependent interface (DI) crossover, eliminating the need for crossover cables or cross-wire (MDIX) ports
- Bail latch provides ease of extraction
- Compact RJ45 connector assembly
- Data scrambled to reduce radiated emission
- Power consumption is 340mW typical
- Fully RoHS compliant



Part Number	Description
SFP-1GBT-01	SGMII to 10/100Base-T SFP BroadR-Reach™ Mode

The BCM54810S physical layer IC (PHY) can be accessed via I²C interface:
 PHY address = “ACh” for transceivers with serial number 0000000225 and higher.
 PHY address = “82h” or “01” binary for transceivers with serial number 0000000224 and lower.
 The EEPROM memory address = “A0h”

The Bel SFP-1GBT-01 transceiver is internally configured for copper 10/100 BroadR-Reach™ mode. The host interface transmits and receives serial data differentially at 1.25 Gbps.

- SFP Transceiver identification is specified as “08h” for byte 6 in the EEPROM.

REGULATORY AND STANDARDS COMPLIANCE

- Compliant with IEEE 802.3
- FCC Part 15, Class A
- EN55022 Class A (CISPR 22 Class A)
- Meets requirements of relevant European Directives (CE)
- E55024 Immunity standard and NEBS 3 ESD

APPLICATIONS

- 10/100 Mbps data rate with an extended reach of 300 to 500 meters when using high quality Category 5/5e cable
- Networking equipment
- Switches-to-switches interface
- Routers

©2011 Bel Fuse Inc. Specifications subject to change without notice. 10.17.11

RELIABILITY TESTING

Vibration Test: Reference MIL-STD-202, Method 204. Condition D.

Mechanical Shock: Reference IEC 68-2-27, Test Ea. Alternative MIL-STD-202, Method 213B, Condition A.

Temperature cycling and temperature-humidity-bias.



SFP-1BGT-01 MODULE SPECIFICATIONS

Parameter	Symbol	Min	Typ	Max	Units	Notes
Supply Voltage	V_{DD3}	3.12	3.3	3.46	V	
Supply Current	I_S		100		mA	

SFP Host Serial Interface (TX/RX)	Symbol	Min	Typ	Max	Units	Notes
Line Frequency	F_{LINE}		125		MHz	
TX Output Impedance	Z_{TX_OUT}		100		Ω	Differential
RX Output Impedance	Z_{RX_IN}		100		Ω	Differential
Clock Frequency			25		MHz	
Rise/Fall Time	T_R/T_F		4		ns	20% - 80%
RMS Phase Jitter	F_J			1.5	ps-rms	$F_J = 12$ kHz to 20 MHz offset frequency

Environmental Specifications	Symbol	Min	Typ	Max	Units	Notes
Operating Temp	T_{OP}	0		+70	$^{\circ}C$	Case temperature
Storage Temp	T_{STG}	-40		+85	$^{\circ}C$	Ambient temperature

SFP Copper Transceiver 10/100 BroadR-Reach™
SFP-1GBT-01



SFP HOST CONNECT ELECTRICAL INTERFACE AND PINS DESCRIPTIONS

Pin	Name	Description
1	VeeT	Transmitter ground (common with receiver ground).
2	TX Fault	Transmitter fault is internally tied to transmit ground and is not supported.
3	TX Disable	Transmit disable. This pin is tied to PHY low power mode.
4	MOD-DEF2	Signal SDA (data) of the two-wire serial ID interface.
5	MOD-DEF1	Signal SCL (data) of the two-wire serial ID interface.
6	MOD-DEF0	This pin is internally tied to transmit ground.
7	Rate Select	Not implemented. This pin is floating internally.
8	LOS	Loss of signal indication.
9	VeeR	Receiver ground (common with transmitter ground).
10	VeeR	Receiver ground (common with transmitter ground).
11	VeeR	Receiver ground (common with transmitter ground).
12	RD-	Differential receiver outputs. User to terminate to 100 Ω differential at host. AC coupled.
13	RD+	Differential receiver outputs. User to terminate to 100 Ω differential at host. AC coupled.
14	VeeR	Receiver ground (common with transmitter ground).
15	VccR	3.3V power
16	VccT	3.3V power
17	VeeT	Transmitter ground (common with receiver ground).
18	TD+	Differential transmitter outputs. User to terminate to 100 Ω differential at host. AC coupled.
19	TD-	Differential transmitter outputs. User to terminate to 100 Ω differential at host. AC coupled.
20	VeeT	Transmitter ground (common with receiver ground).



MECHANICAL

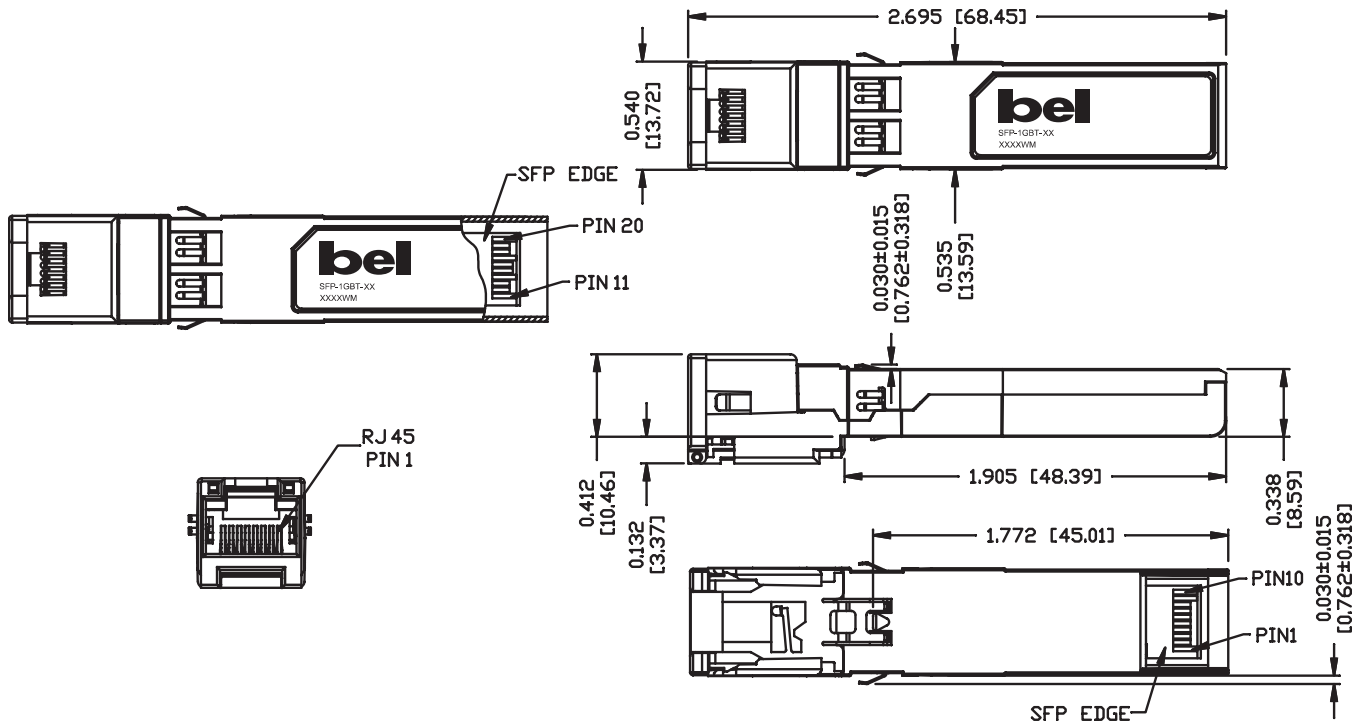

©2011 Bel Fuse Inc. Specifications subject to change without notice. 10.17.11

CORPORATE

Bel Fuse Inc.
206 Van Vorst Street
Jersey City, NJ 07302
Tel 201-432-0463
Fax 201-432-9542
www.belfuse.com

ASIA

Bel Fuse Ltd.
8F / 8 Luk Hop Street
San Po Kong
Kowloon, Hong Kong
Tel 852-2328-5515
Fax 852-2352-3706
www.belfuse.com

EUROPE

Bel Stewart Connector
45/46 Riverside
Medway City Estate
Rochester, Kent ME2 4DP U.K.
Tel 44-1634-722890
Fax 44-1634-716677
www.belfuse.com