



Dear customers,

About the change in the name such as "Oki Electric Industry Co. Ltd." and "OKI" in documents to OKI Semiconductor Co., Ltd.

The semiconductor business of Oki Electric Industry Co., Ltd. was succeeded to OKI Semiconductor Co., Ltd. on October 1, 2008. Therefore, please accept that although the terms and marks of "Oki Electric Industry Co., Ltd.", "Oki Electric", and "OKI" remain in the documents, they all have been changed to "OKI Semiconductor Co., Ltd.". It is a change of the company name, the company trademark, and the logo, etc. , and NOT a content change in documents.

October 1, 2008
OKI Semiconductor Co., Ltd.

OKI SEMICONDUCTOR CO., LTD.

550-1 Higashiasakawa-cho, Hachioji-shi, Tokyo 193-8550, Japan
<http://www.okisemi.com/en/>

MSC7166

16-Bit Grid Driver with 4 to 16-Decoder

GENERAL DESCRIPTION

The MSC7166 is a driver IC designed to directly drive the grids of a vacuum fluorescent display tube.

Since this IC has a built-in 4 to 16-line decoder and 16 output circuits, a signal device of MSC7166 can replace a set of the following three: two devices of either MSL912 or MSL918 and one device of either MSM4514 or MSM74HC4514.

Setting the DUTY pin to the "L" level makes all driver outputs go "L". Blanking can be set using this function.

FEATURES

- Logic supply voltage : 5V
- Driver supply voltage : 65V
- Driver output current I_{OH} : -40 mA
 I_{OL} : 1 mA
- Can be directly connected to VF display tube without pull-down resistor
- Built-in 4- to 16-line decoder
- Brightness can be adjusted by DUTY pin
- Package
24-pin plastic SOP (SOP24-P-430-1.27-K) (Product name: MSC7166GS-K)

BLOCK DIAGRAM

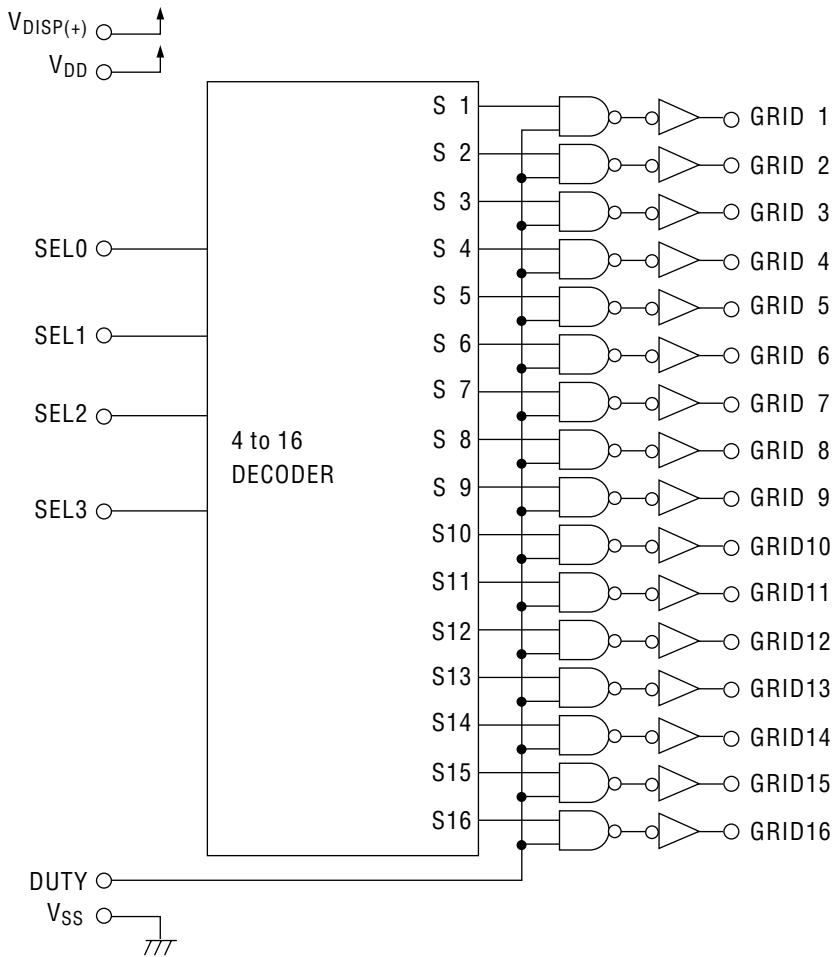

INPUT AND OUTPUT CONFIGURATION

Schematic Diagram of Logic Input Circuit

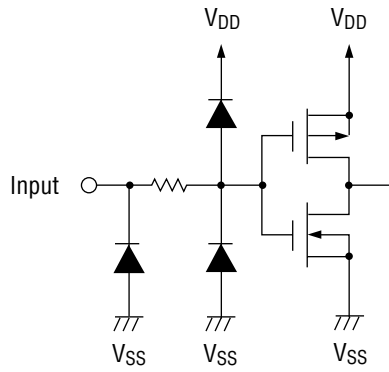

Schematic Diagram of Driver Output Circuit

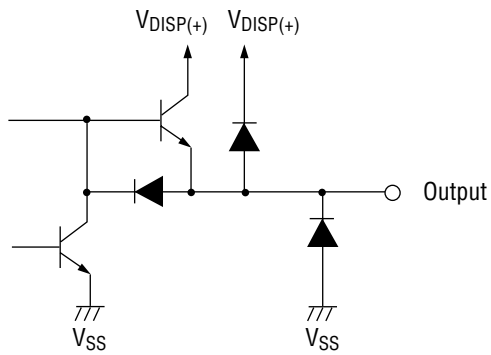

PIN CONFIGURATION (TOP VIEW)

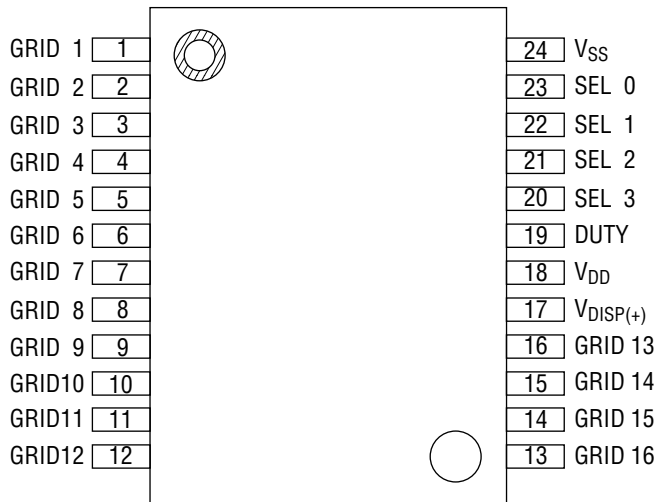

24-pin Plastic SOP

PIN DESCRIPTIONS

Symbol	Type	Description
SELO-3	I	4- to 16-line decoder input pins. The input 4-bit binary signals are converted into hexadecimal signals, then output through driver output pins.
DUTY	I	Duty control signal input pin. Setting this pin to "L" makes all driver outputs go "L", so this pin can be used for brightness control.
GRID1-16	O	High withstand voltage driver output pins for driving fluorescent display tube. These pins can directly be connected to the grid of fluorescent display tube without pull-down resistor.
V _{DISP(+)}	—	Power supply pin for the fluorescent display tube driver circuit.
V _{DD}	—	Logic power supply pin.
V _{SS}	—	Ground pin.

ABSOLUTE MAXIMUM RATINGS

Parameter	Symbol	Condition	Rating	Unit
Logic Supply Voltage	V _{DD}	Applied to logic supply pin	-0.3 to +6.5 *1	V
Driver Supply Voltage	V _{DISP(+)}	Applied to driver supply pin	-0.3 to +70 *1,2	V
Input Voltage	V _{IN}	Applied to all input pins	-0.3 to V _{DD} +0.3 *1	V
Power Dissipation	P _D	T _a ≤25°C	790	mW
Thermal Resistance of Package	R _{j-a}	—	158 *3	°C/W
Storage Temperature	T _{STG}	—	-55 to +150	°C

*1 The maximum supply voltage for V_{SS}.

*2 Permanent damage to the device may be caused if the voltage is supplied over the the absolute maximum rating value.

*3 Thermal resistance of the package (between junction and atmosphere).

The junction temperature (T_j) given by the equation indicated below should not exceed 150°C.

$$T_j = P \times R_{j-a} + T_a \quad (P: \text{maximum power consumption of IC})$$

RECOMMENDED OPERATING CONDITIONS

Parameter	Symbol	Condition	Min.	Max.	Unit
Logic Supply Voltage	V _{DD}	Applied to logic supply pin	4.5	5.5	V
Driver Supply Voltage	V _{DISP(+)}	Applied to driver supply pin	8	65	V
High Level Input Voltage	V _{IH}	Applied to all input pins	3.1	—	V
Low Level Input Voltage	V _{IL}	Applied to all input pins	—	1.7	V
High Level Output Current	I _{OH}	Applied to all driver output pins	—	-40	mA
Low Level Output Current	I _{OL}	Applied to all driver output pins	—	1.0	mA
Operating Temperature	T _{op}	—	-40	85	°C
Input Pulse Rise Time	t _r	Applied to all input pins	—	1.0	μs
Input Pulse Fall Time	t _f	Applied to all input pins	—	1.0	μs

ELECTRICAL CHARACTERISTICS

DC Characteristics

($V_{DD}=4.5$ to $5.5V$, $V_{DISP(+)}=8$ to $65V$, $T_a=-40$ to $+85^{\circ}C$)

Parameter	Symbol	Condition	Min.	Typ.	Max.	Unit
Logic Supply Current	I_{DD1}	No load, 1 output H	—	—	4.8	mA
	I_{DD2}	No load, DUTY=L	—	—	5.0	mA
Driver Supply Current	I_{DISP1}	No load, 1 output H	—	—	0.3	mA
	I_{DISP2}	No load, DUTY=L	—	—	1.0	μA
High Level Input Current	I_{IH}	—	—	—	± 1	μA
Low Level Input Current	I_{IL}	—	—	—	± 1	μA
High Level Output Voltage	V_{OH}	$I_{OH}=-40mA$	$V_{DISP(+)}-4$	—	—	V
Low Level Output Voltage	V_{OL}	$I_{OL}=1mA$	—	—	2.5	V

AC Characteristics

($V_{DD}=4.5$ to $5.5V$, $V_{DISP(+)}=8$ to $65V$, $T_a=-40$ to $+85^{\circ}C$)

Parameter	Symbol	Condition	Min.	Typ.	Max.	Unit
Delay Time L to H	t_{DLH}	$C_L=10pF$, See figure below	—	0.3	1.0	μs
Transient Time L to H	t_{TLH}	$C_L=10pF$, See figure below	—	2.0	4.0	μs
Delay Time H to L	t_{DHL}	$C_L=10pF$, See figure below	—	0.3	1.0	μs
Transient Time H to L	t_{THL}	$C_L=10pF$, See figure below	—	2.0	4.0	μs

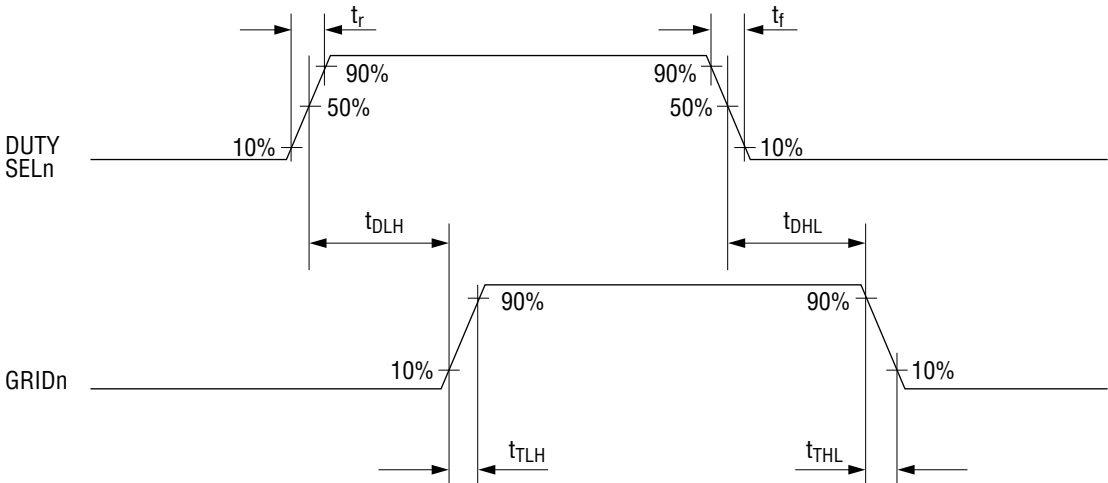

FUNCTION DESCRIPTION

Functional Table

DUTY	SEL				GRID																	
	0	1	2	3	1	2	3	4	5	6	7	8	9	10	11	12	13	14	15	16		
L	X	X	X	X	L	L	L	L	L	L	L	L	L	L	L	L	L	L	L	L	L	
	L	L	L	L	H	L	L	L	L	L	L	L	L	L	L	L	L	L	L	L	L	
H	H	L	L	L	L	H	L	L	L	L	L	L	L	L	L	L	L	L	L	L	L	
	L	H	L	L	L	L	H	L	L	L	L	L	L	L	L	L	L	L	L	L	L	
	H	H	L	L	L	L	L	H	L	L	L	L	L	L	L	L	L	L	L	L	L	
	L	L	H	L	L	L	L	L	H	L	L	L	L	L	L	L	L	L	L	L	L	
	H	L	H	L	L	L	L	L	L	H	L	L	L	L	L	L	L	L	L	L	L	
	L	H	H	L	L	L	L	L	L	L	H	L	L	L	L	L	L	L	L	L	L	
	H	H	L	L	L	L	L	L	L	L	L	L	L	L	L	L	L	L	L	L	L	
	L	H	H	L	L	L	L	L	L	L	L	L	L	L	L	L	L	L	L	L	L	
	H	H	H	L	L	L	L	L	L	L	L	L	L	L	L	L	L	L	L	L	L	
	L	L	H	H	L	L	L	L	L	L	L	L	L	L	L	L	L	H	L	L	L	
	H	L	H	H	L	L	L	L	L	L	L	L	L	L	L	L	L	L	H	L	L	
	L	H	H	H	L	L	L	L	L	L	L	L	L	L	L	L	L	L	L	H	L	
	H	H	H	H	L	L	L	L	L	L	L	L	L	L	L	L	L	L	L	L	L	H

PACKAGE DIMENSIONS

(Unit : mm)

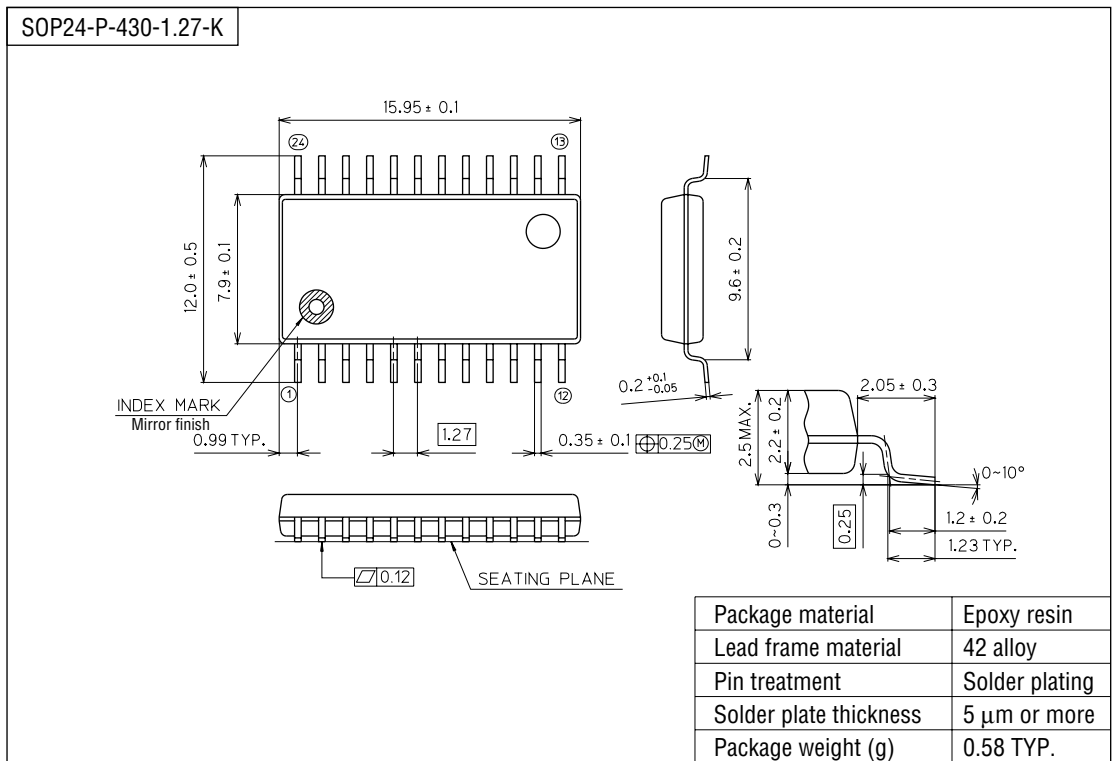

Notes for Mounting the Surface Mount Type Package

The SOP, QFP, TSOP, SOJ, QFJ (PLCC), SHP and BGA are surface mount type packages, which are very susceptible to heat in reflow mounting and humidity absorbed in storage. Therefore, before you perform reflow mounting, contact Oki's responsible sales person for the product name, package name, pin number, package code and desired mounting conditions (reflow method, temperature and times).