

FEATURES

- LOW OPERATING VOLTAGE ($V_{CC} = 13.5\text{ V}$)
- TITANIUM-PLATINUM-GOLD METALLIZATION FOR HIGH RELIABILITY
- SUPERIOR RF PERFORMANCE
- HIGH GAIN
- RUGGED VSWR $\infty: 1$ at $V_{CC} = 16\text{ V}$
- FOR 800 MHz BAND MOBILE RADIO APPLICATIONS
- LOW COST PACKAGES
- HIGH POWER

DESCRIPTION

NEC's NE0800 series of NPN epitaxial UHF power transistors is designed for large volume mobile radio applications in the 800 MHz band. The series is available in two low cost packages. High gain, power and efficiency, combined with low cost packages, make the NE0800 series an ideal choice for large volume applications in the 800 MHz mobile radio band.

The series solves the metal migration problem by using NEC's famous Pt-si/Ti/Pt/Au system rather than conventional aluminum or tungsten-gold metallization. NEC's proprietary fabrication technique employed in the series features ion-implantation base regions, arsenic doped polysilicon emitter structure, porous SiO_2 under bonding pads to reduce parasitic capacitance and silicon nitride passivation (Si_3N_4).

ELECTRICAL CHARACTERISTICS ($T_A = 25^\circ\text{C}$)

PART NUMBER EIAJ ¹ REGISTERED NUMBER PACKAGE OUTLINE			NE080190,91 2SC2558K,M 90,91			NE080490,91 2SC2559K,M 90,91			NE081090,91 2SC2850K,M 90,91		
SYMBOLS	PARAMETERS AND CONDITIONS	UNITS	MIN	TYP	MAX	MIN	TYP	MAX	MIN	TYP	MAX
P_{OUT}	Output Power at $V_{CC} = 13.5\text{ V}$, $f = 860\text{ MHz}$ $P_{IN} = 20\text{ dBm}$ $P_{IN} = 29.5\text{ dBm}$ $P_{IN} = 36\text{ dBm}$	dBm dBm dBm	30	32.5		36	37.8		39.5	40.2	
η_c	Collector Efficiency at $V_{CC} = 13.5$, $f = 860\text{ MHz}$ $P_{IN} = 20\text{ dBm}$ $P_{IN} = 29.5\text{ dBm}$ $P_{IN} = 36\text{ dBm}$	% % %	50	55		55	60		65	75	
VSWR	Voltage Standing Wave Ratio at $V_{CC} = 13.5\text{ V}$, $f = 860\text{ MHz}$ $P_{OUT} = 32\text{ dBm}$ $P_{OUT} = 37.5\text{ dBm}$ $P_{OUT} = 41\text{ dBm}$		∞			∞			∞		
E_{VCBO}	Collector to Base Breakdown Voltage at $I_E = 0$ $I_C = 100\text{ }\mu\text{A}$ $I_C = 1\text{ mA}$ $I_C = 2\text{ mA}$	V V V	35			35			35		
E_{VCEO}	Collector to Emitter Breakdown Voltage at $I_B = 0$ $I_C = 1\text{ mA}$ $I_C = 10\text{ mA}$ $I_C = 20\text{ mA}$	V V V	18			18			18		
E_{VEBO}	Emitter to Base Breakdown Voltage at $I_C = 0$ $I_E = 100\text{ }\mu\text{A}$ $I_E = 1\text{ mA}$ $I_E = 2\text{ mA}$	V V V	3			3			3		
I_{CBO}	Collector Cutoff Current at $V_{CB} = 20\text{ V}$, $I_E = 0$	mA			0.1			0.2			0.4
I_{EBO}	Emitter Cutoff Current at $V_{EB} = 2\text{ V}$, $I_C = 0$	mA			0.1			0.2			0.4
hFE	DC Forward Current Gain at $V_{CE} = 10\text{ V}$, $I_C = 100\text{ mA}$ (pulsed) $I_C = 300\text{ mA}$ (pulsed) $I_C = 500\text{ mA}$ (pulsed)		20	60	200	20	60	200	20	60	200
C_{OB}	Output Capacitance at $V_{CB} = 10\text{ V}$, $I_E = 0$, $f = 1\text{ MHz}^2$	pF		2.3	3.5		7	10		14	20

Notes:

1. Electronic Industrial Association of Japan.
2. Emitter and flange are rounded.

NE0800-12 SERIES

ABSOLUTE MAXIMUM RATINGS¹ (T_A = 25°C)

SYMBOLS	PARAMETERS	UNITS	RATINGS
V _{CB0}	Collector to Base Voltage	V	35
V _{CE0}	Collector to Emitter Voltage	V	18
V _{EB0}	Emitter to Base Voltage	V	3
I _c	Collector Current	A	0.5 1.5 3
R _{TH(J-C)}	Thermal Resistance (Junction to Case)	°C/W	21 10 5
P _T	Total Power Dissipation (T _c = 25°C)	W	8.3 17.5 35
T _J	Junction Temperature	°C	200
T _{STG}	Storage Temperature	°C	-65 to +150

Notes:

- Operation in excess of any one of these parameters may result in permanent damage.

TYPICAL PERFORMANCE CURVES (T_A = 25°C)

NE081090(91)
OUTPUT POWER AND COLLECTOR
EFFICIENCY vs. INPUT POWER

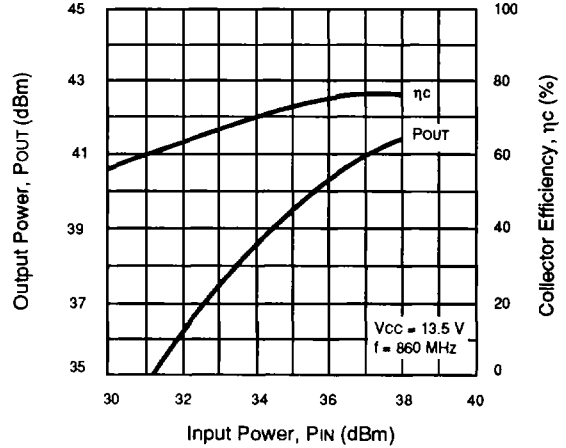

NE080190(91)
OUTPUT POWER AND COLLECTOR
EFFICIENCY vs. INPUT POWER

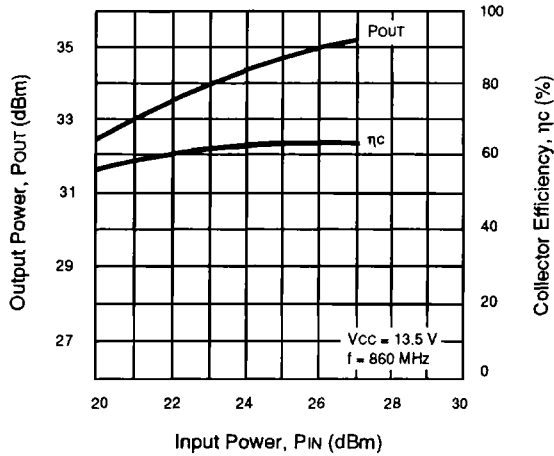

NE080490(91)
OUTPUT POWER AND COLLECTOR
EFFICIENCY vs. INPUT POWER

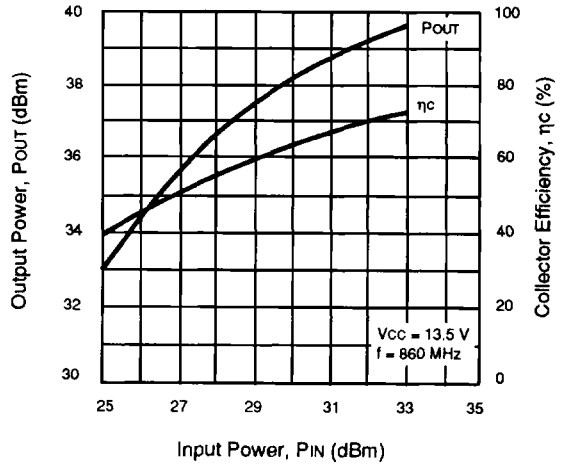

OUTLINE DIMENSIONS (Units in mm)

PACKAGE OUTLINE 90

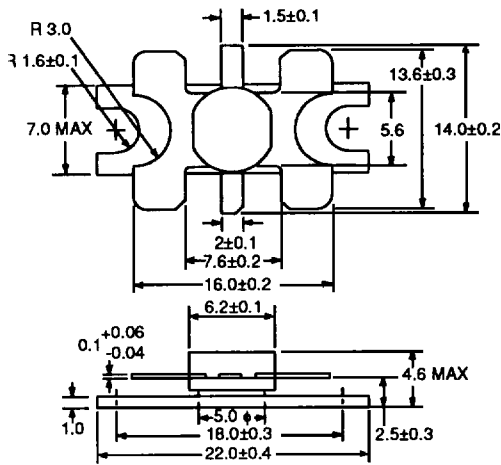

PACKAGE OUTLINE 91

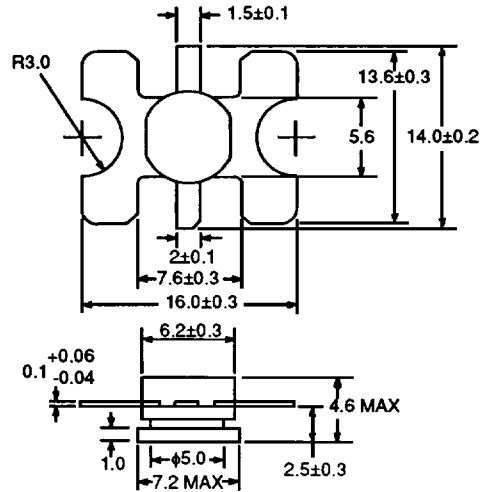

TEST CIRCUIT

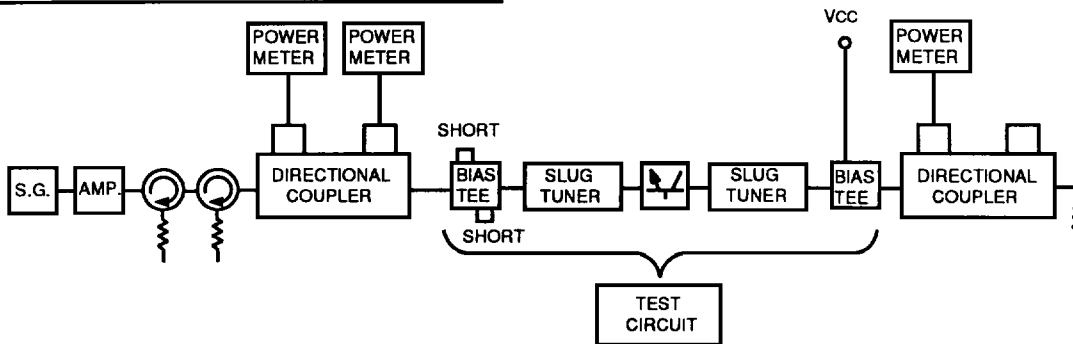

4

APPLICATIONS

800 MHz MOBILE RADIO BAND (VCC = 13.5V)

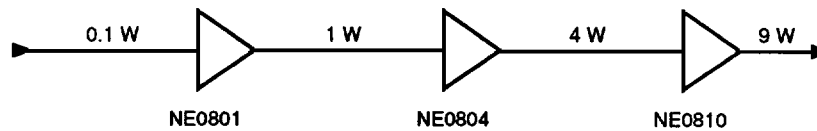

TYPICAL INPUT/OUTPUT LOAD IMPEDANCE¹

PART NUMBER	P _{IN} (dBm)	Z _{IN} (Ω)	Z _{OUT} (Ω)
NE080190(91)	20	144+j2.62	9.65-j17.6
NE080490(91)	29.5	1.16+j6.14	6.02-j0.86
NE081090(91)	36	2.64+j7	5.16+j1.3

Note:

1. Typical large signal impedances at V_{CC} = 13.5, f = 860 MHz, T_A = 25°C.

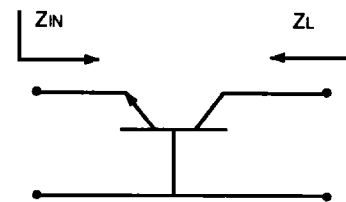

Z_L is optimum load impedance at rated output power.