

MN3412

12 BIT 4 QUADRANT
MULTIPLYING
D/A CONVERTER

FEATURES

- Full Four Quadrant Operation
- Gain Error
 $\pm 1/2$ LSB @ 25°C
 ± 1 LSB - 55 to +125°C
- Low Feedthrough Error
- Low Phase Shift Error
- Internal Output Op Amp
- TTL Compatible

32 PIN MODULE

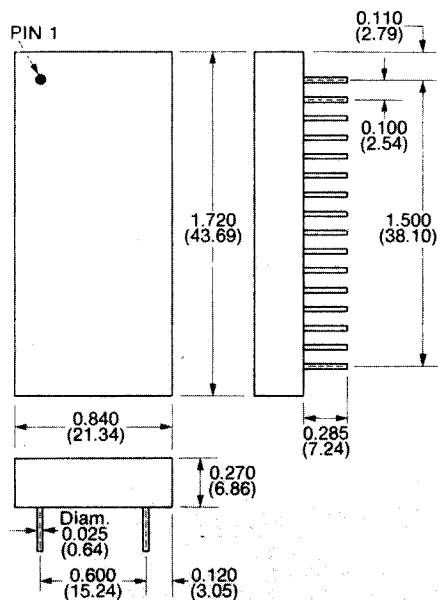

Dimensions in Inches
(Millimeters)

DESCRIPTION

The MN3412 is the most accurate, 12 Bit, multiplying D/A converter available in a Dual-in-Line configuration. Precision thin-film hybrid circuits and functional laser trimming are used to enable the MN3412 to maintain $\pm 1/2$ LSB gain error at +25°C and ± 1 LSB gain error from -55°C to +125°C.

This unparalleled accuracy can be used to provide high performance in both 4 quadrant multiplying and fixed reference applications. In addition, critical parameters for multiplying applications are clearly presented and defined. The MN3412 maintains 12 bit linearity with reference voltages down to 250 mV and better than 10 bit linearity with reference voltages as low as 30 mV. Feed-through is typically 80 dB down at 400 Hz, and settling time is only 20 μ Sec for a 20 V step. Phase shift characteristics are also excellent.

The MN3412 uses a voltage switched R-2R ladder network configuration to achieve outstanding performance over temperature. Linearity is guaranteed to be less than $\pm 1/2$ LSB from -55°C to +125°C. Gain drift is a low 1 ppm/°C, and offset drift a low 5 μ V/°C.

APPLICATIONS

The MN3412 is an excellent choice for high performance multiplying applications in computational and servo systems, and for high accuracy data conversion when used with a precision fixed reference. Additional applications include: digital-to-synchro converters, programmable-gain amplifiers, and ratiometric analog-to-digital converters.

MN3412



Micro Networks

A DIVISION OF UNITRODE CORPORATION
324 Clark Street, Worcester, MA 01606 • Tel: (617) 852-5400

MN3412 12 BIT D/A CONVERTER

ABSOLUTE MAXIMUM RATINGS

Storage Temperature	-65°C to +150°C
Operating Temperature	0°C to +70°C -55°C to +125°C "H" Models
Supply Voltages	
+V _{CC} (Pin 15)	+18 Volts
-V _{CC} (Pin 25)	-18 Volts
Logic (Pin 10)	+8 Volts
Digital Inputs	-V _{CC} to V _{LOGIC}
Reference Input (Pin 32)	±15Volts

ORDERING INFORMATION

PART NUMBER	MN3412H
Standard device is specified for 0°C to +70°C operation. Add "H" suffix for -55°C to +125°C operation.	

SPECIFICATIONS (T_A = 25°C, Supply Voltages ±15V and +5V, unless otherwise specified).

Logic Levels: Logic "1" Logic "0"	2.0		0.8	Volts Volts
Input Currents: Logic "1" Logic "0"			2 2	μA μA
Bipolar Output Range (Note 3) Output Impedance Output Load Current	±5	±11 1.0		Volts Ohm mA
Linearity Error (Note 1): 0°C to +70°C -55°C to +125°C ("H" Model)		± ¼	± ½ ± ½	LSB LSB
Gain Accuracy: +25°C 0°C to +70°C -55°C to +125°C ("H" Model)			± ½ ±1 ±1	LSB LSB LSB
Gain Drift: 0°C to +70°C -55°C to +125°C ("H" Model)		±1.5 ±1		ppm/°C ppm/°C
Zero Error (Note 2) +25°C Zero Drift -55°C to +125°C		±5	±5	mV μV/°C
Voltage Range (Note 3) Input Current (Note 4)	-11		+11 13	Volts mA
Settling Time (20 volt change to ± ½ LSB) Digital Inputs to Output (Fixed Reference) Reference Input to Output (Fixed Code)			20 20	μSec μSec
Small Signal Bandwidth (Note 5) Large Signal Bandwidth (Note 6) Output Slew Rate		1.4 125 3.3		MHz KHz V/μSec
Worst Case Glitch Digital Inputs to Output (Fixed Reference) Amplitude Settling Time Glitch Energy		3.5 4.5 1.25		Volts μSec mV-μSec
Power Supply Range (Note 7): +V _{CC} -V _{CC} +V _{LOGIC}	+11.0 -11.0 +4.75	+15.0 -15.0 +5.0	+18.0 -18.0 +5.25	Volts Volts Volts
Power Supply Rejection (Notes 7,8): +15V Supply -15V Supply		±0.002 ±0.002	±0.005 ±0.005	% FSR /% Vs % FSR /% Vs
Current Drain, Output Unloaded: +15V Supply -15V Supply +5V Supply		1 -16 16	3 -20 20	mA mA mA
Power Consumption		335	445	mW

SPECIFICATION NOTES:

1. Micro Networks tests and guarantees maximum linearity error at room temperature and at both extremes of the operating temperature range.
2. Zero Error is the error measured when the digital input of the converter is 1000 0000 0000 (0V output).
3. The output voltage of the MN3412 can go to $\pm 11V$ with $\pm V_{CC} = \pm 15V$. For linear operation, V_{REF} should be at least 4 volts less than $\pm V_{CC}$. See Note 7.
4. If the $-15V$ supply is disconnected, the reference input will short to ground. To avoid damage to the device under these conditions, the reference input current should be externally limited to 50 mA maximum.
5. Small Signal Bandwidth is the frequency at which a $0.1V_{p-p}$ Reference input signal is attenuated 3dB.
6. Large Signal Bandwidth is the frequency at which a $20V_{p-p}$ Reference input signal is attenuated 3dB.
7. The MN3412 will operate over a $\pm V_{CC}$ power supply range of $\pm 11V$ to $\pm 18V$. We test and guarantee Power Supply Rejection over the $\pm 15V \pm 3\%$ range.
8. FSR stands for Full Scale Range and is equivalent to 20 volts for the MN3412.

BLOCK DIAGRAM

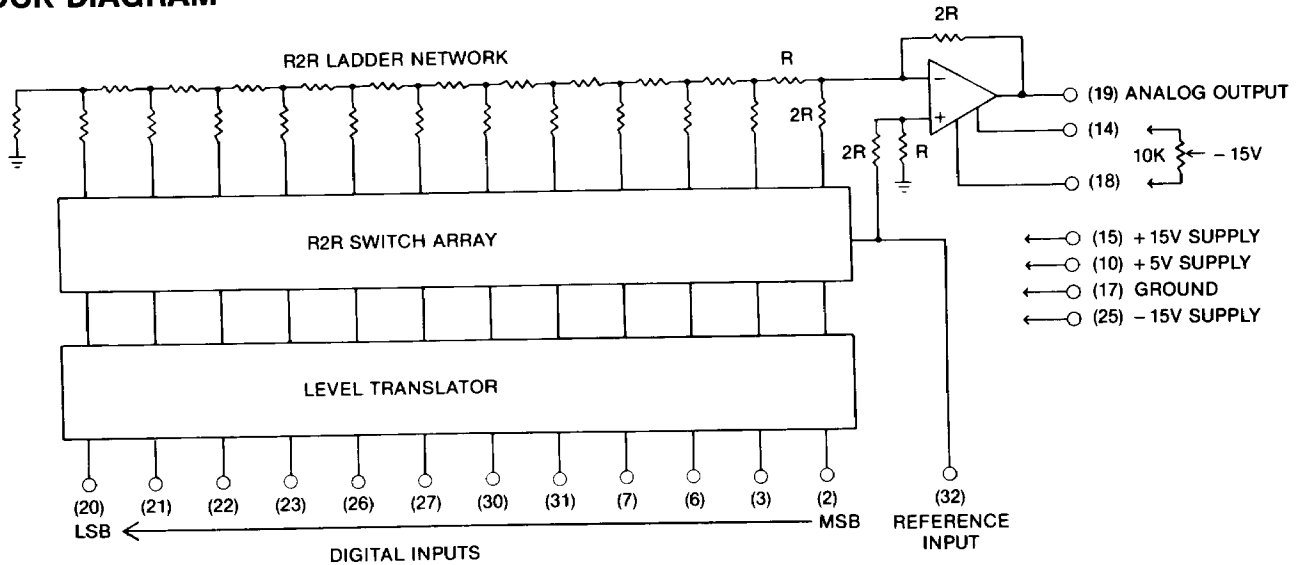

INPUT CODING

DIGITAL INPUTS		ANALOG OUTPUT (DC VOLTS)
MSB	LSB	
1111 1111 1111		$-0.99951 V_{REF}$
1000 0000 0001		$-0.00049 V_{REF}$
1000 0000 0000		$0.00000 V_{REF}$
0111 1111 1111		$+0.00049 V_{REF}$
0100 0000 0000		$+0.50000 V_{REF}$
0000 0000 0001		$+0.99951 V_{REF}$
0000 0000 0000		$+1.00000 V_{REF}$

PIN DESIGNATIONS

- | | |
|------------------|--------------------|
| 1 N/C | 32 Reference Input |
| 2 Bit 1 (MSB) | 31 Bit 5 |
| 3 Bit 2 | 30 Bit 6 |
| 4 N/C | 29 N/C |
| 5 N/C | 28 N/C |
| 6 Bit 3 | 27 Bit 7 |
| 7 Bit 4 | 26 Bit 8 |
| 8 N/C | 25 $-15V$ Supply |
| 9 N/C | 24 N/C |
| 10 $+5V$ Supply | 23 Bit 9 |
| 11 N/C | 22 Bit 10 |
| 12 N/C | 21 Bit 11 |
| 13 N/C | 20 Bit 12 (LSB) |
| 14 Zero Adjust | 19 Analog Output |
| 15 $+15V$ Supply | 18 Zero Adjust |
| 16 N/C | 17 Ground |

APPLICATIONS INFORMATION

LAYOUT CONSIDERATIONS — Proper attention to layout and decoupling is necessary to obtain specified accuracy from the MN3412. The unit's Ground (Pin 17) must be tied to circuit analog ground as close to the package as possible, preferably through a large ground plane underneath the package.

Power supplies should be decoupled with tantalum or electrolytic type capacitors located close to the unit. For optimum performance, $1 \mu F$ capacitors paralleled with $0.01 \mu F$ ceramic capacitors should be used as shown in the diagrams at the top of the next page.

POWER SUPPLY DECOUPLING

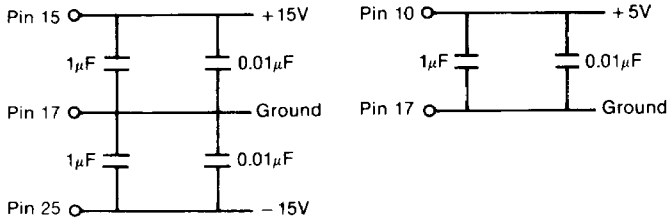

In addition, coupling between analog and digital signals should be minimized to avoid noise pick-up. Short leads should be used when connecting the external reference to the Reference Input (Pin 32) or when using the optional Zero Adjustment (Pins 14 and 18).

ZERO ADJUSTMENT — The MN3412 meets all specifications without external adjustment. However, accuracy can be further improved by zero adjustment. To

adjust zero connect a 10K potentiometer as shown below, apply code 1000 0000 0000, and adjust the potentiometer for zero volts at the output.

A multiturn potentiometer with a TCR of 100ppm/°C or less is recommended to minimize drift with temperature.

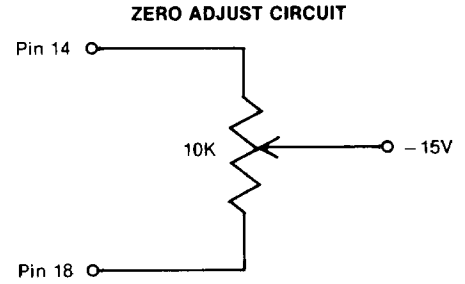

REFERENCE REQUIREMENTS — The reference input of the MN3412 can draw up to 13 mA from the reference source. Care should be taken to insure that the reference source can provide adequate drive.

TYPICAL CHARACTERISTICS

($T_A = 25^\circ\text{C}$, Supplies $\pm 15\text{V}$)

