

Series  
**NSX**

NONENVIRONMENTAL SIZE 2 RECEPTACLE CONNECTOR  
Q11 - BLANK - 34 INSERTS

Issue :  
Sept. 08, 2011

Page :  
**1/2**

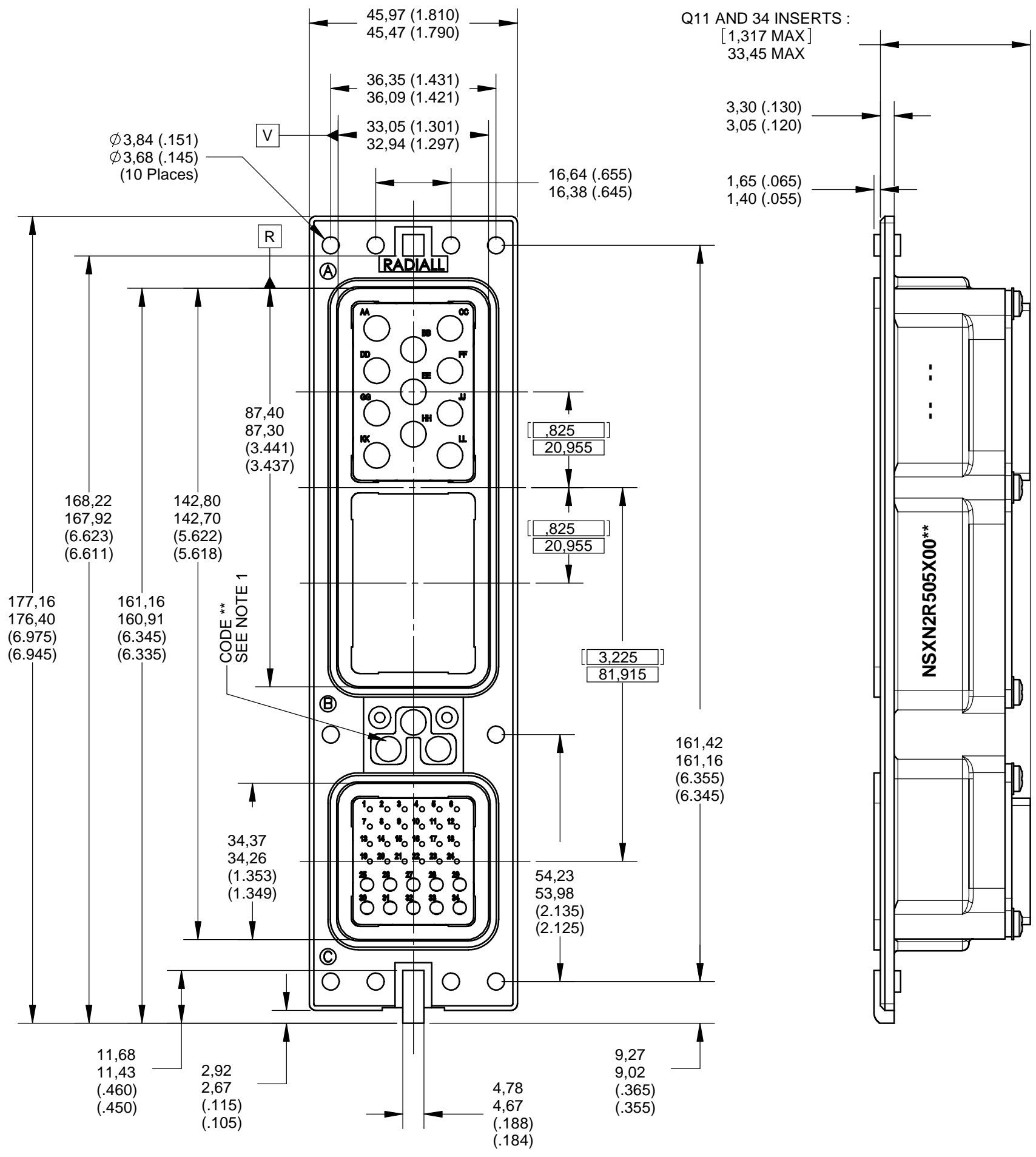

**NOTE 1 :**  
\*\* REPRESENTS THE POLARIZATION CODE AND IS CONFORM WITH ARINC 600 POLARIZATION POSITION  
WITHOUT POLARIZATION CODE, THE CONNECTOR IS DELIVERED WITH POLARIZATION HARDWARE UNASSEMBLED  
CODE 00 : THE CONNECTOR IS DELIVERED WITHOUT POLARIZING KEY

DIMENSIONS : mm (inch are given for information only)

CREATION  PEN: /  NOM: MOUTAULT DATE: Sept. 08, 2011 APPR.: DUPUIS				
	Issue	Revisions	Name	Approved

Confidential information not to be disclosed to third parties without Radiall approval. This information is given as an indication, in the continual goal to improve our products, we reserve the right to make any modifications judged necessary.

4112\_9311



**MATERIAL:**

- SHELL : DIE CAST ALUMINUM ALLOY PER SAE AMS-QQ-A-591
- INSERT RETENTION PLATES : ALUMINUM ALLOY PER SAE AMS-QQ-A-250
- POLARIZING RETENTION PLATE : ALUMINUM ALLOY PER SAE AMS-QQ-A-250
- POLARIZING KEYS : ZINC ALLOY PER ASTM B 86
- 34 INSERT : REINFORCED EPOXY RESIN PER ASTM D 5948 OR HIGH GRADE THERMOPLASTIC
- Q11 INSERT : ALUMINUM ALLOY PER SAE AMS-QQ-A-250
- CONTACT RETENTION CLIPS : BERYLLIUM COPPER PER ASTM B 194
- COVER : THERMOPLASTIC CONDUCTIVE ELASTOMER
- SCREWS AND WASHERS : CORROSION RESISTANT MATERIAL

**FINISH:**

- SHELL : CHROMATATION PER MIL-DTL-5541, CLASS 3
- INSERT RETENTION PLATES : ELECTROLESS NICKEL PER SAE AMS-2404
- POLARIZING RETENTION PLATE : ANODIC OXYDATION PER MIL-A-8625 CLASS 2 TYPE IIB
- POLARIZING KEYS : ELECTROLESS NICKEL PER SAE AMS-2404
- Q11 METALIC INSERT : ELECTROLESS NICKEL PER SAE AMS-2404
- CONTACT BODY : PLATING .00005 INCH OF GOLD PER SAE AMS-2422 OVER NICKEL PER AMS 2403
- CONTACT PROTECTIVE SLEEVE : PASSIVATED

**NOTES:**

- INSERT LAYOUT :
  - CAVITY A : Q11 FOR REAR RELEASE, REAR REMOVABLE COAX, TRIAX OR QUADRAX CONTACTS  
SIZE 8 CAVITIES ARE GROUNDED TO THE SHELL
  - CAVITY B : BLANK
  - CAVITY C : 34 FOR REAR RELEASE, REAR REMVABLE POWER CONTACTS
- CONNECTOR SUPPLIED WITHOUT CONTACT
- COVER P/N : 620 995 015 & 620 995 016 (INSTALLED)
- POLARIZING HARDWARE IS SHIPPED LOOSE WITH THE CONNECTOR
- MARKING: CONNECTOR AND PACKAGING MUST BE MARKED WITH : NSXN2R505X00\*\* + DATE CODE  
(CODE \*\* : SEE NOTE 1 PAGE 1)

Confidential information not to be disclosed to third parties without Radiall approval  
This information is given as an indication. In the continual goal to improve our products, we reserve the right to make any modifications judged necessary.

4112\_9311