



SANYO Semiconductors

DATA SHEET

LB11852FV

Monolithic Digital IC
For Fan Motor
Single-phase Full-wave Pre-driver
with Speed Control Function

Overview

The LB11852FV is a single-phase bipolar driving motor pre-driver with a speed control function based on speed feedback. With a small number of external parts, a highly efficient and very quiet variable-speed drive fan motor with low power consumption and high rotational accuracy can be implemented. The LB11852FV, integrated in a miniature package, is best suited for driving small fan motors requiring speed control.

Features

- Single-phase full-wave driving pre-driver
 - ⇒ With a PMOS-NMOS device used as the external power transistor, low saturation output and a single-phase full-wave drive enable a high-efficiency drive with low power consumption.
- Speed control circuit incorporated
 - ⇒ Compared with open-loop control, a closed-loop control function that uses speed feedback to control the speed makes it possible to improve the rotational speed accuracy and reduce the variations in the rotational speed caused by fluctuations in the supply voltage or load. The separately excited upper direct PWM method is featured as the variable speed system.
- Variable speed control is possible with external PWM input or analog voltage input
 - ⇒ The speed control input signal is compatible with PWM duty ratio and analog voltages.
- Soft start circuit incorporated
- Minimum speed setting pin
 - ⇒ The minimum speed can be set using an external resistor.
- Current limiting circuit incorporated
 - ⇒ Chopper type current limit at startup or lock.
- Reactive current cut circuit incorporated
 - ⇒ Reactive current before phase changeover is cut, ensuring highly silent and low power-consumption drive.
- Automatic resetting type constraint circuit incorporated
- FG (rotational speed detection) output

■ Any and all SANYO Semiconductor Co.,Ltd. products described or contained herein are, with regard to "standard application", intended for the use as general electronics equipment (home appliances, AV equipment, communication device, office equipment, industrial equipment etc.). The products mentioned herein shall not be intended for use for any "special application" (medical equipment whose purpose is to sustain life, aerospace instrument, nuclear control device, burning appliances, transportation machine, traffic signal system, safety equipment etc.) that shall require extremely high level of reliability and can directly threaten human lives in case of failure or malfunction of the product or may cause harm to human bodies, nor shall they grant any guarantee thereof. If you should intend to use our products for applications outside the standard applications of our customer who is considering such use and/or outside the scope of our intended standard applications, please consult with us prior to the intended use. If there is no consultation or inquiry before the intended use, our customer shall be solely responsible for the use.

■ Specifications of any and all SANYO Semiconductor Co.,Ltd. products described or contained herein stipulate the performance, characteristics, and functions of the described products in the independent state, and are not guarantees of the performance, characteristics, and functions of the described products as mounted in the customer's products or equipment. To verify symptoms and states that cannot be evaluated in an independent device, the customer should always evaluate and test devices mounted in the customer's products or equipment.

SANYO Semiconductor Co., Ltd.

TOKYO OFFICE Tokyo Bldg., 1-10, 1 Chome, Ueno, Taito-ku, TOKYO, 110-8534 JAPAN

LB11852FV

Specifications

Absolute Maximum Ratings at $T_a = 25^\circ\text{C}$

Parameter	Symbol	Conditions	Ratings	Unit
V_{CC} pin maximum supply voltage	V_{CC} max		18	V
OUTN pin maximum output current	IOUTN max		20	mA
OUTP pin maximum Sink current	IOUTP max		20	mA
OUT pin output withstand voltage	VOUT max		18	V
HB maximum output current	HB		10	mA
CTL, C pin withstand voltage	CTL, C max		7	V
CVI, LIM pin withstand voltage	CVI, LIM max		7	V
RD/FG output pin output withstand voltage	FG max		19	V
RD/FG output current	FG max		10	mA
5VREG pin maximum output current	I5VREG max		10	mA
Allowable power dissipation	Pd max	Mounted on a specified board *1	0.8	W
Operating temperature	Topr		-30 to 95	$^\circ\text{C}$
Storage temperature	Tstg		-55 to 150	$^\circ\text{C}$

*1 Mounted on a specified board : 114.3mm×76.1mm×1.6mm, glass epoxy

*2 T_j max = 150°C . Use the device in a condition that the chip temperature does not exceed $T_j = 150^\circ\text{C}$ during operation.

Recommended Operating Conditions at $T_a = 25^\circ\text{C}$

Parameter	Symbol	Conditions	Ratings	Unit
V_{CC} supply voltage 1	V_{CC1}	V_{CC} pin	5.5 to 16	V
V_{CC} supply voltage 2	V_{CC2}	V_{CC} -5VREG	4.5 to 5.5	V
CTL input voltage range	VCTL		0 to 5VREG	V
LIM input voltage range	VLIM		0 to 5VREG	V
VCI input voltage range	VCVI		0 to 5VREG	V
Hall input common phase input voltage range	VICM		0.2 to 3	V

Electrical Characteristics at $T_a = 25^\circ\text{C}$, $V_{CC} = 12\text{V}$, unless otherwise specified

Parameter	Symbol	Conditions	Ratings			Unit
			min	typ	max	
Circuit current	I_{CC1}	During drive		12	15	mA
	I_{CC2}	During lock protection		12	15	mA
5VREG voltage	5VREG	I5VREG = 5mA	4.8	5.0	5.2	V
Current limiting voltage	VLIM		190	210	230	mV
CPWM pin H level voltage	V_{CRH}		2.8	3.0	3.2	V
CPWM pin L level voltage	V_{CRL}		0.9	1.1	1.3	V
CPWM pin charge current	I_{CPWM1}	$V_{CPWM} = 0.5\text{V}$	24	30	36	μA
CPWM pin discharge current	I_{CPWM2}	$V_{CPWM} = 3.5\text{V}$	21	27	33	μA
CPWM oscillation frequency	F _{PWM}	C = 220pF		30		kHz
CT pin H level voltage	V_{CTH}		2.8	3.0	3.2	V
CT pin L level voltage	V_{CTL}		0.9	1.1	1.3	V
CT pin charge current	I_{CT1}	$V_{CT} = 2\text{V}$	1.6	2.0	2.5	μA
CT pin discharge current	I_{CT2}	$V_{CT} = 2\text{V}$	0.16	0.20	0.25	μA
CT pin charge/discharge current ratio	R_{CT}	I_{CT1}/I_{CT2}	8	10	12	times
OUTN pin output H voltage	V_{ONH}	$I_O = 10\text{mA}$		$V_{CC}-0.85$	$V_{CC}-1.0$	V
OUTN pin output L voltage	V_{ONL}	$I_O = 10\text{mA}$		0.9	1.0	V
OUTP pin output L voltage	V_{OPL}	$I_O = 10\text{mA}$		0.5	0.65	V
Hall input sensitivity	VHN	IN^+ , IN^- differential voltage (including offset and hysteresis)		± 15	± 25	mV

Continued on next page.

LB11852FV

Continued from preceding page.

Parameter	Symbol	Conditions	Ratings			Unit
			min	typ	max	
FG output L voltage	V_{FGL}	$I_{FG} = 5\text{mA}$		0.15	0.30	V
FG pin leak current	I_{FGL}	$V_{FG} = 19\text{V}$			30	μA
EO pin output H voltage	V_{EOH}	$I_{EO1} = -0.2\text{mA}$	VREG-1.2	VREG-0.8		V
EO pin output L voltage	V_{EOL}	$I_{EO1} = 0.2\text{mA}$		0.8	1.1	V
RC pin output H voltage	V_{RCH}		3.2	3.45	3.7	V
RC pin output L voltage	V_{RCL}		0.7	0.8	1.05	V
RC pin clamp voltage	V_{RCCLP}		1.3	1.5	1.7	V
CTL pin input H voltage	V_{CTLH}		2.0		VREG	V
CTL pin input L voltage	V_{CTLL}		0		1.0	V
CTL pin input open voltage	V_{CTLO}		VREG-0.5		VREG	V
CTL pin H input H current	I_{CTLH}	$V_{FGIN} = 5\text{VREG}$	-10	0	10	μA
CTL pin L input L current	I_{CTLL}	$V_{FGIN} = 0\text{V}$	-120	-90		μA
C pin output H voltage	V_{CH}		VREG-0.3	VREG-0.1		V
C pin output L voltage	V_{CL}		1.8	2.0	2.2	V
LIM pin input bias current	I_{BLIM}		-1		1	μA
LIM pin common phase input voltage range	V_{LIM}		2.0		VREG	V
SOFT pin charge current	I_{CSOFT}		1.0	1.3	1.6	μA
SOFT pin operating voltage range	V_{ISOFT}		2.0		VREG	V

Package Dimensions

unit : mm (typ)

3360

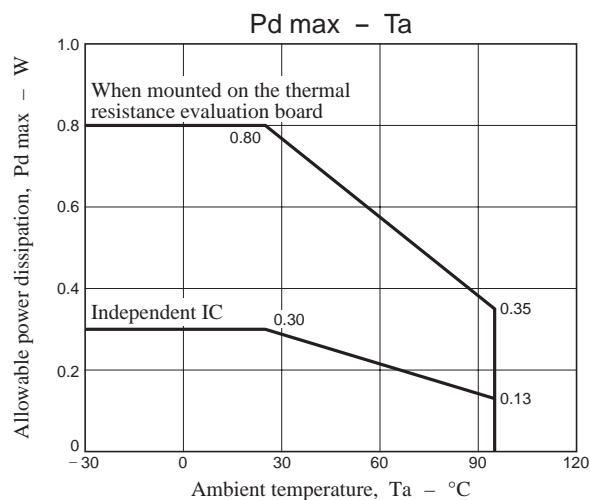
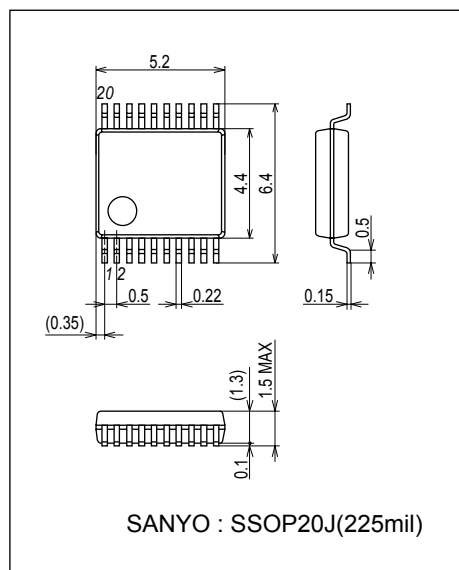

LB11852FV

Truth table

Lock protection CPWM = H

IN ⁻	IN ⁺	CT	OUT1P	OUT1N	OUT2P	OUT2N	FG	Mode
H	L	L	L	L	OFF	H	L	OUT1 → 2 drive
L	H		OFF	H	L	L	OFF	OUT2 → 1 drive
H	L	H	OFF	L	OFF	H	L	Lock protection
L	H		OFF	H	OFF	L	OFF	

Speed control CT = L

EO	CPWM	IN ⁻	IN ⁺	OUT1P	OUT1N	OUT2P	OUT2N	Mode
L	H	H	L	L	L	OFF	H	OUT1 → 2 drive
		L	H	OFF	H	L	L	OUT2 → 1 drive
H	L	H	L	OFF	L	OFF	H	Regeneration mode
		L	H	OFF	H	OFF	L	

Pin Assignment

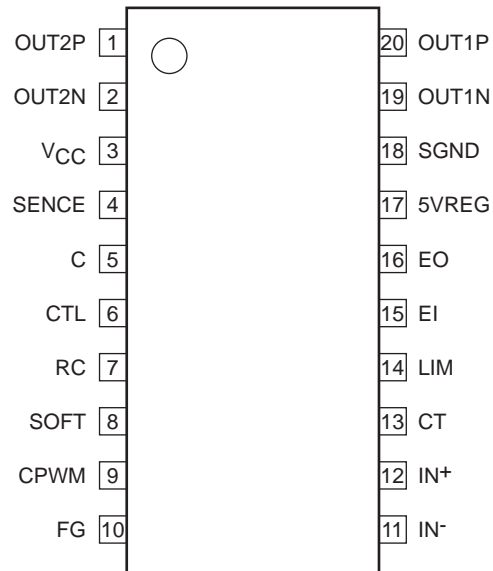

Top view

Block Diagram

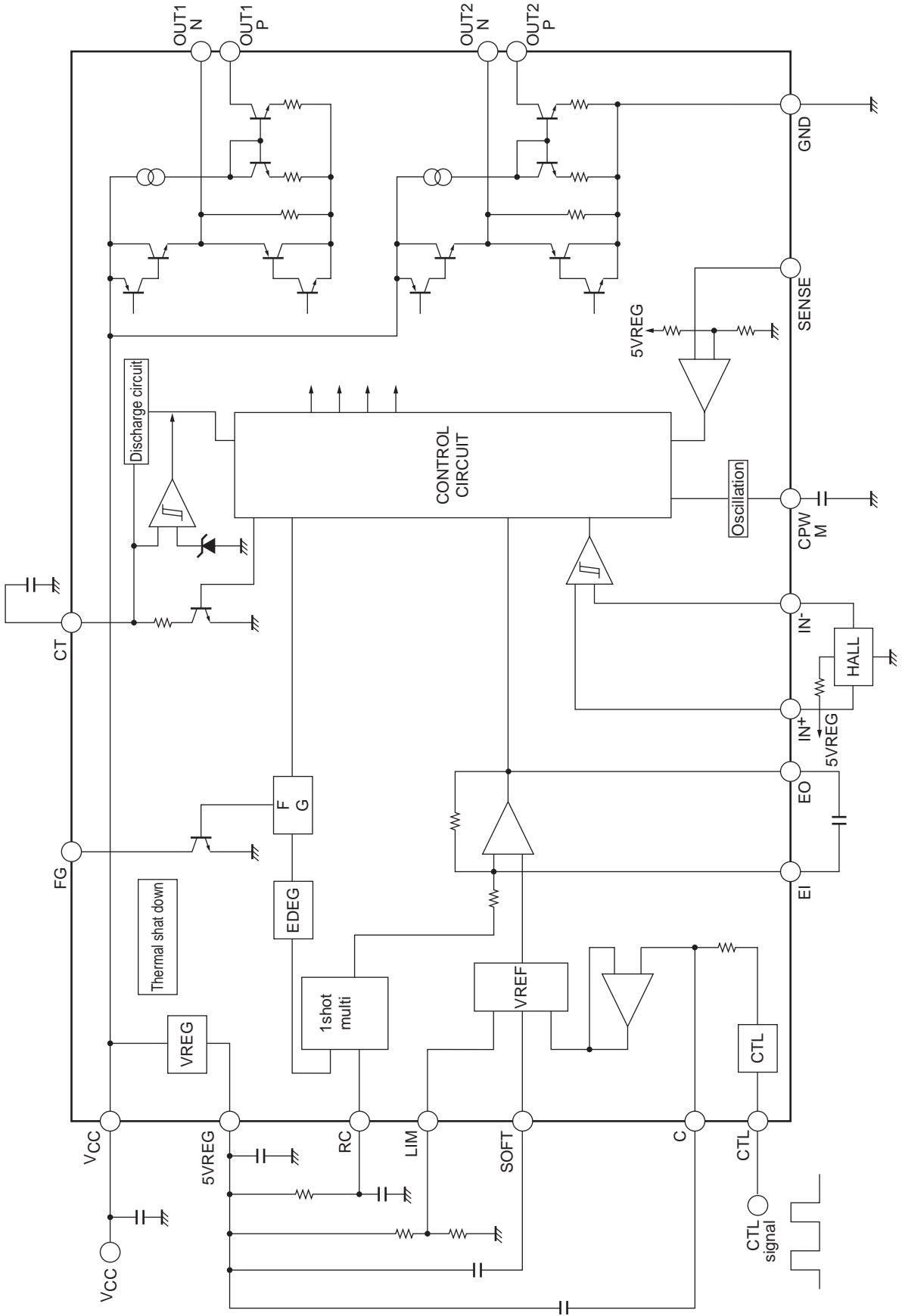

LB11852FV

Sample Application Circuit

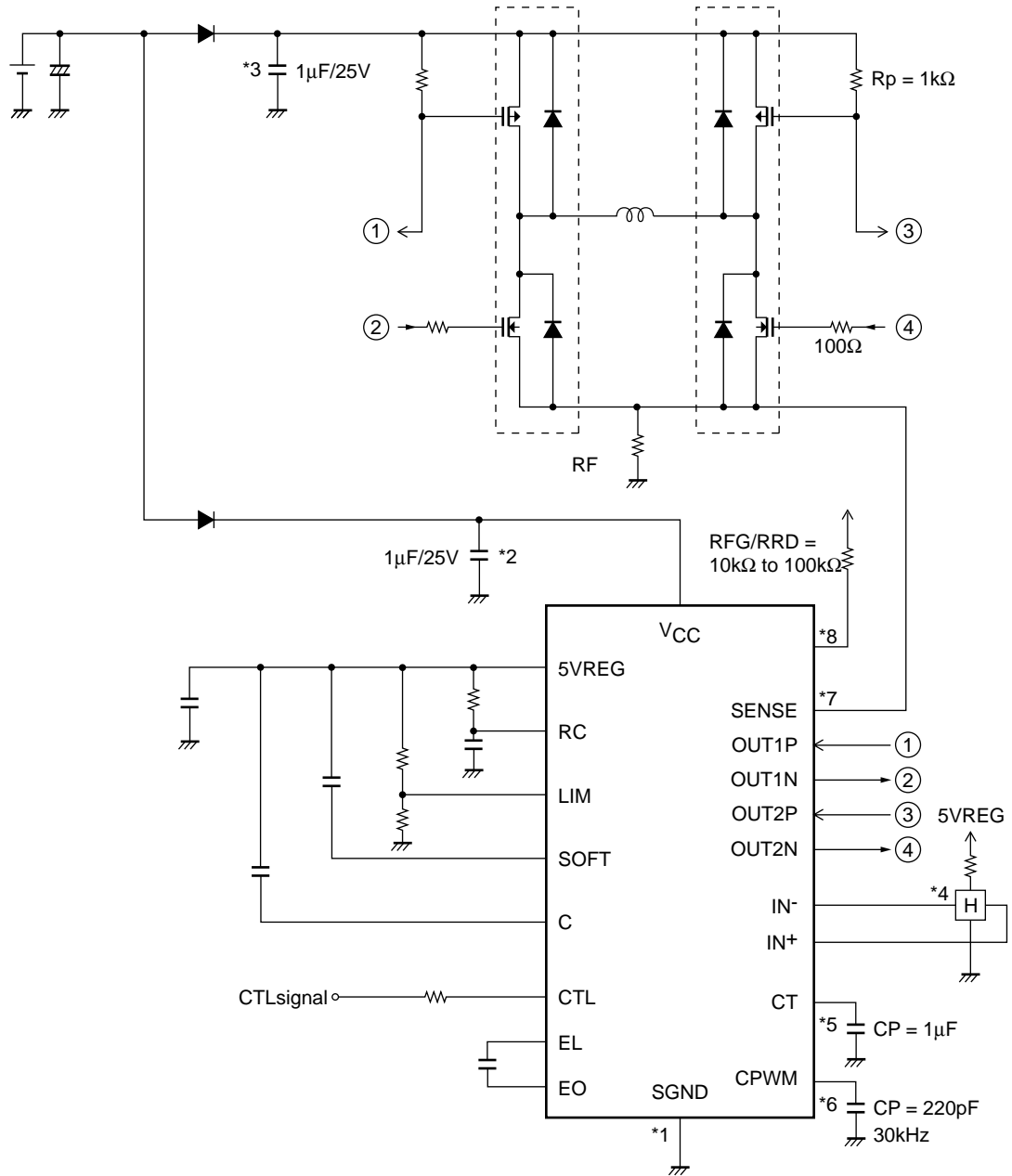

Description of Pre-driver Bock

***1 : Power-GND wiring**

The SGND is connected to the control circuit power supply system.

***2 : Power stabilization capacitor**

For the power stabilization capacitor on the signal side, use a capacitor of 0.1 μ F or more. Connect the capacitor between V_{CC} and GND with a thick and along the shortest possible route.

***3 : Power-side power stabilization capacitor**

For the power-side power stabilization capacitor, use a capacitor of 1 μ F or more. Connect the capacitor between the power-side power supply and GND with a thick and along the shortest possible route.

***4 : IN⁺, IN⁻ pins**

Hall signal input pins

Wiring should be short to prevent noise from being carried.

If noise is carried, insert a capacitor between the IN⁺ and IN⁻ pins.

The Hall input circuit functions as a comparator with hysteresis (15mV).

It also has a soft switch zone with ± 30 mV (input signal difference voltage).

It is also recommended that the Hall input level should be a minimum of 100mV (p-p).

***5 : CPWM pin**

Pin to connect the capacitor used to generate the PWM basic frequency

Use of CP = 200pF causes oscillation at f = 30kHz, which is the basic frequency of PWM.

As this is also used for the current limiter reset signal, a capacitor must be connected even if the speed is not going to be controlled.

***6 : CT pin**

Pin to connect the capacitor used for lock detection

The constant-current charging and constant-current discharging circuits incorporated cause locking when the pin voltage reaches 3.0V, and releasing the lock protection when it drops to 1.0V.

Connect this pin to the GND when it is not to be used (locking not necessary).

***7 : SENSE pin**

Current limiter detection pin

When the pin voltage exceeds 0.21V, the current limiter is activated, and operation enters lower regeneration mode.

Connect this pin to the GND when it is not to be used.

***8 : FG pin**

Rotational speed detection pin

This is an open collector output that can detect the rotational speed using the FG output corresponding to the phase changeover.

Keep this pin open when it is not to be used.

LB11852FV

Description of Speed Control Block

1. Speed control diagram

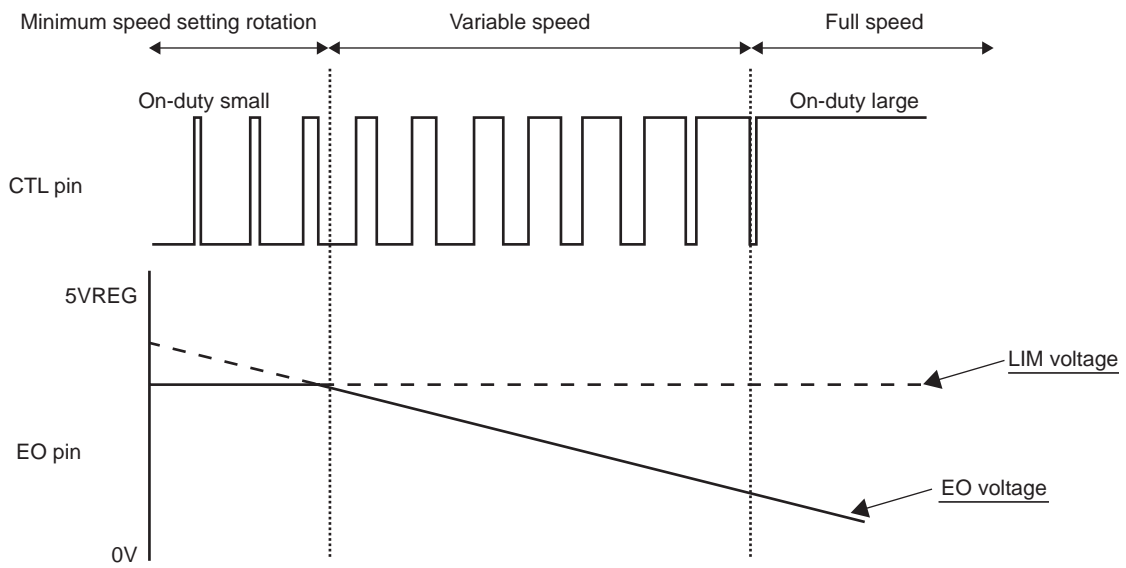
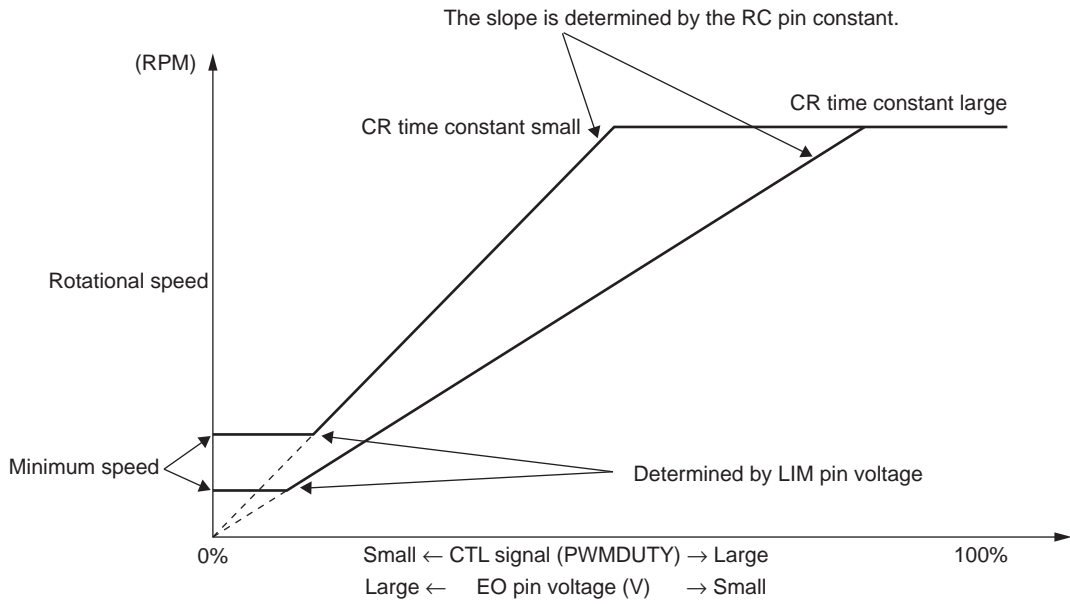

2. Timing at startup (soft start)

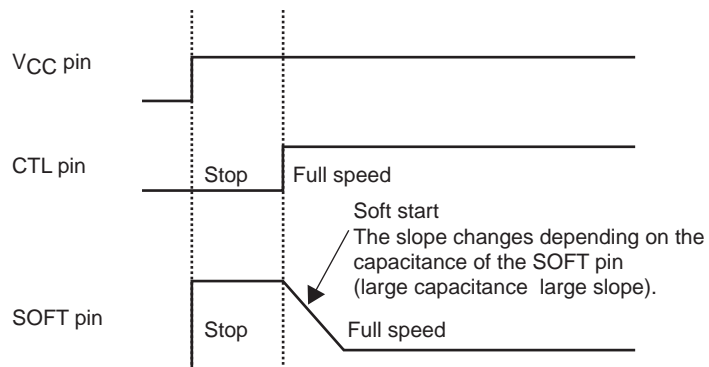

2. Supplementary description of operations

By inputting the duty pulses, a feedback loop is formed inside the LB11852 IC to establish the FG period (rotational speed of the motor) that corresponds to the control voltage of the pulses.

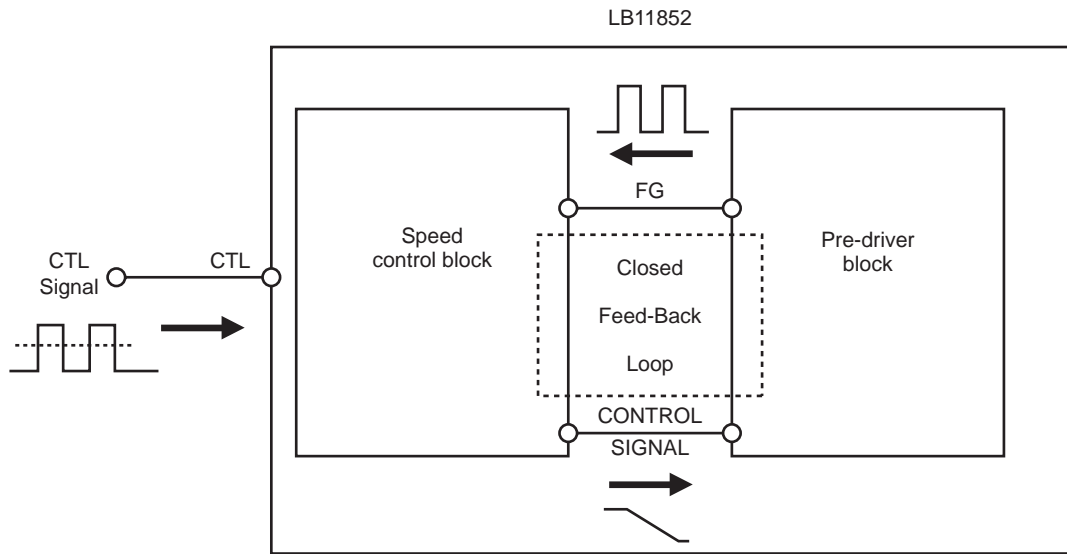

The operation inside the IC is as follows. Pulse signals are created from the edges of the FG signals as shown in the figure below, and using these signals as a reference, waveforms with a pulse width determined by the CR time constant are generated using a one-shot multivibrator. These pulse waveforms are then integrated to control the duty ratio of the pre-driver output as the control voltage.

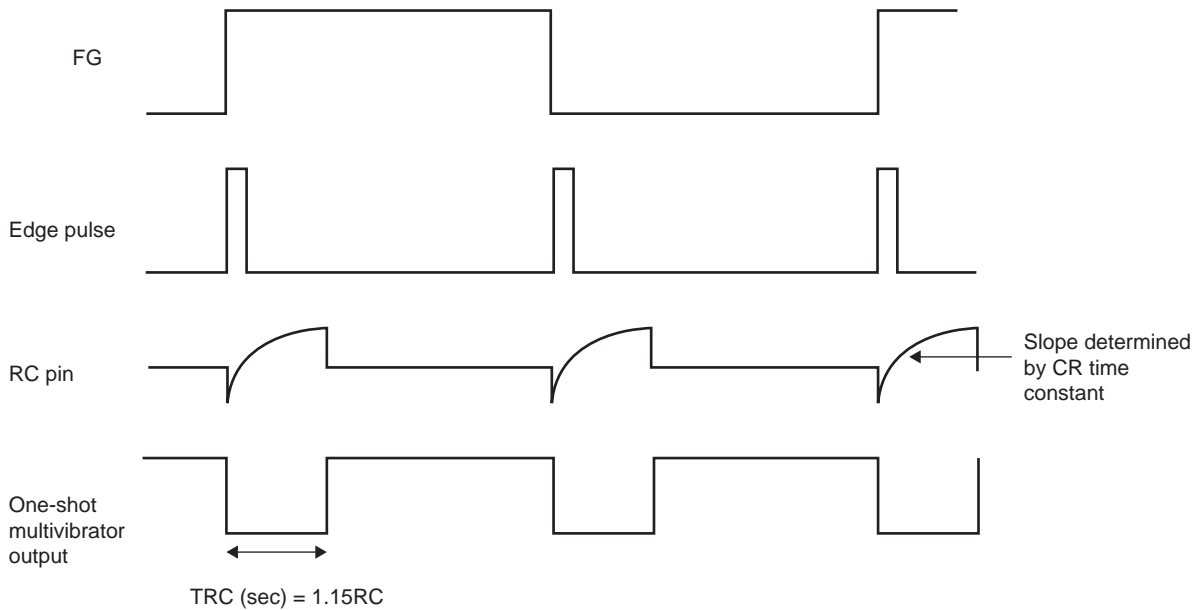

By changing the pulse width as determined by the CR time constant, the VCTL versus rotational speed slope can be adjusted as shown in the speed control diagram in the previous section.

However, since pulses that are determined by the CR time constant are used, the CR variations are output as-is as the speed control error.

4. Procedure for calculating the constant

<RC pin>

The slope shown in the speed control diagram is determined by the constant of the RC pin.

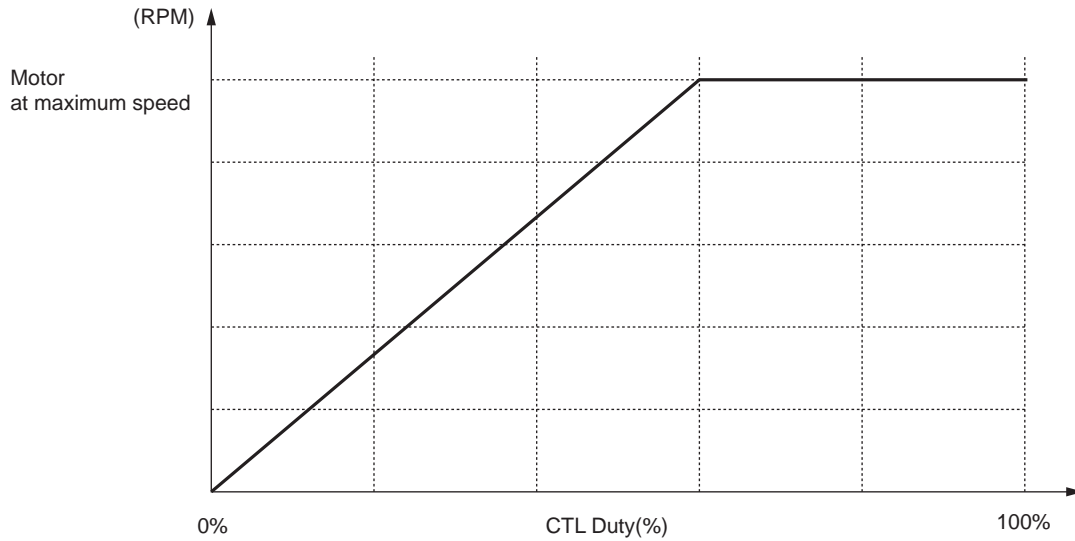

- 1) Obtain the FG signal frequency f_{FG} (Hz) at the maximum rotational speed of the motor (with two FG pulses per rotation).

$$f_{FG} \text{ (Hz)} = 2 \text{ rpm}/60 \cdots (1)$$

- 2) Obtain the time constant of the components connected to the RC pin

(use the duty ratio (example : 100% = 1.0 or 60% = 0.6) as the CTL duty ratio for achieving the maximum rotational speed).

$$R \times C = \text{Duty ratio} / (3.3 \times 1.1 \times f_{FG}) \cdots (2)$$

- 3) Obtain the resistance and the capacitance of the capacitor.

Based on the discharge capability of the RC pin, the capacitance of the capacitor which can be used is in the range of $0.01\mu\text{F}$ to $0.015\mu\text{F}$.

Therefore, obtain the appropriate resistance from the result of (2) above using the formula in (3) or (4) below.

$$R = (R \times C) / 0.01\mu\text{F} \cdots (3)$$

$$R = (R \times C) / 0.015\mu\text{F} \cdots (4)$$

The temperature characteristics of the curve are determined by the temperature characteristics of the capacitor of the RC pin. To minimize the variations in the rotational speed caused by temperature, a capacitor with excellent temperature characteristics must be used.

<LIM pin>

The minimum speed is determined by the voltage of the LIM pin.

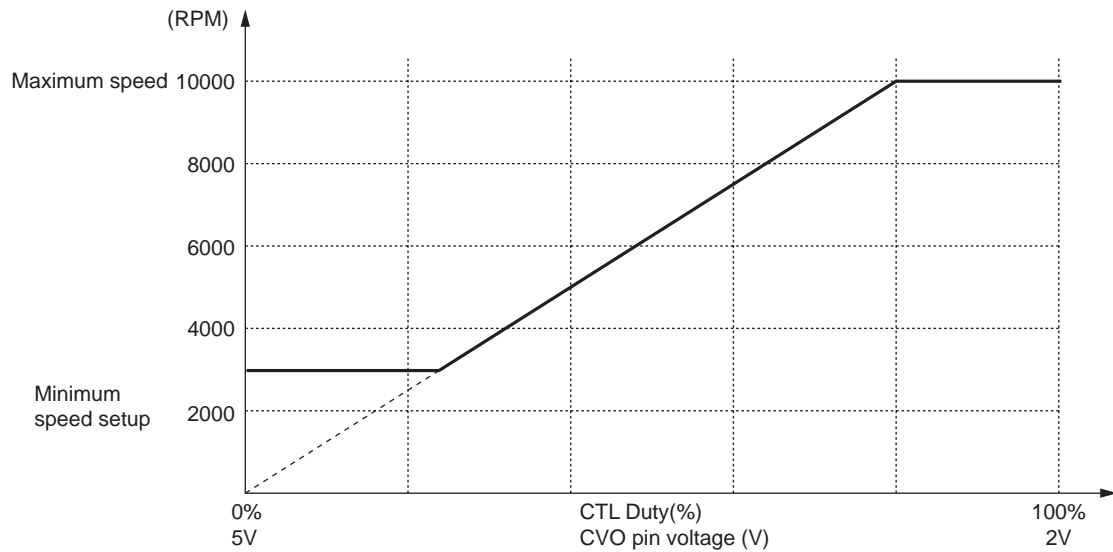

1) Obtain the ratio of the minimum speed required to the maximum speed.

$$Ra = \text{Minimum/maximum speed} \cdots (1)$$

In the example shown in the figure above : $Ra = \text{minimum/maximum speed} = 3000/10000 = 0.3$

2) Obtain the product of the duty ratio at which the maximum speed is achieved and the value in formula (1).

$$Ca = \text{Maximum speed duty ratio} \times Ra \cdots (2)$$

In the example given : $Ca = \text{maximum speed duty ratio} \times Ra = 0.8 \times 0.3 = 0.24$

3) Obtain the required LIM pin voltage.

$$LIM = 5 - (3 \times Ca) \cdots (3)$$

In the example given : $LIM = 5 - (3 \times Ca) = 5 - (3 \times 0.24) \approx 4.3V$

4) Divide the resistance of 5VREG to generate the LIM voltage.

In the example given, the voltage is 4.3V so the resistance ratio is 1 : 6.

The resistance is 10kΩ between 5VREG and LIM and 62kΩ between LIM and GND.

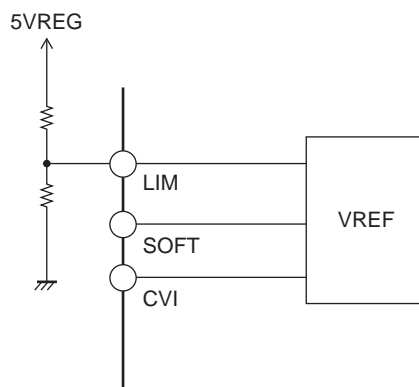

<C pin>

In order to connect a capacitor capable of smoothing the pin voltage to the C pin, the correlation given in the following equation must be satisfied when f (Hz) serves as the input frequency of the CTL pin. (R is incorporated inside the IC, and it is $180\text{k}\Omega$ (typ.)

$$1/f = t < CR$$

The higher the capacitance of the capacitor, the slower the response to changes in the input signals.

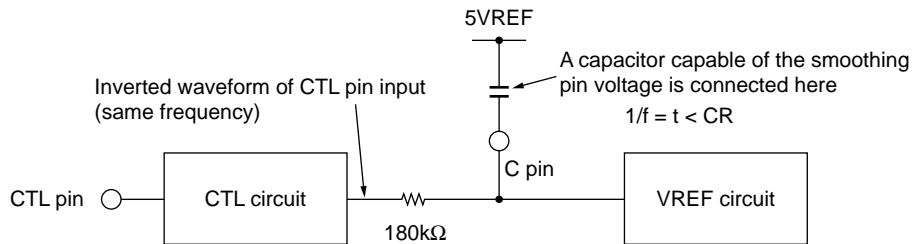

- SANYO Semiconductor Co.,Ltd. assumes no responsibility for equipment failures that result from using products at values that exceed, even momentarily, rated values (such as maximum ratings, operating condition ranges, or other parameters) listed in products specifications of any and all SANYO Semiconductor Co.,Ltd. products described or contained herein.
- SANYO Semiconductor Co.,Ltd. strives to supply high-quality high-reliability products, however, any and all semiconductor products fail or malfunction with some probability. It is possible that these probabilistic failures or malfunction could give rise to accidents or events that could endanger human lives, trouble that could give rise to smoke or fire, or accidents that could cause damage to other property. When designing equipment, adopt safety measures so that these kinds of accidents or events cannot occur. Such measures include but are not limited to protective circuits and error prevention circuits for safe design, redundant design, and structural design.
- In the event that any or all SANYO Semiconductor Co.,Ltd. products described or contained herein are controlled under any of applicable local export control laws and regulations, such products may require the export license from the authorities concerned in accordance with the above law.
- No part of this publication may be reproduced or transmitted in any form or by any means, electronic or mechanical, including photocopying and recording, or any information storage or retrieval system, or otherwise, without the prior written consent of SANYO Semiconductor Co.,Ltd.
- Any and all information described or contained herein are subject to change without notice due to product/technology improvement, etc. When designing equipment, refer to the "Delivery Specification" for the SANYO Semiconductor Co.,Ltd. product that you intend to use.
- Information (including circuit diagrams and circuit parameters) herein is for example only; it is not guaranteed for volume production.
- Upon using the technical information or products described herein, neither warranty nor license shall be granted with regard to intellectual property rights or any other rights of SANYO Semiconductor Co.,Ltd. or any third party. SANYO Semiconductor Co.,Ltd. shall not be liable for any claim or suits with regard to a third party's intellectual property rights which has resulted from the use of the technical information and products mentioned above.

This catalog provides information as of April, 2008. Specifications and information herein are subject to change without notice.