

SN54ALS688, SN74ALS688 8-BIT IDENTITY COMPARATORS

SDAS228A - JUNE 1982 - REVISED JANUARY 1995

- Compare Two 8-Bit Words
- Totem-Pole Outputs ($\overline{P = Q}$)
- 'ALS688 Are Identical to 'ALS521
- Package Options Include Plastic Small-Outline (DW) Packages, Ceramic Chip Carriers (FK), and Standard Plastic (N) and Ceramic (J) 300-mil DIPs

description

These identity comparators perform comparisons on two 8-bit binary or BCD words and provide $\overline{P = Q}$ outputs. These devices have totem-pole outputs.

The SN54ALS688 is characterized for operation over the full military temperature range of -55°C to 125°C . The SN74ALS688 is characterized for operation from 0°C to 70°C .

FUNCTION TABLE

INPUTS		OUTPUT $\overline{P = Q}$
DATA P, Q	ENABLE \overline{G}	
$P = Q$	L	L
$P > Q$	L	H
$P < Q$	L	H
X	H	H

SN54ALS688 ... J PACKAGE
SN74ALS688 ... DW OR N PACKAGE
(TOP VIEW)

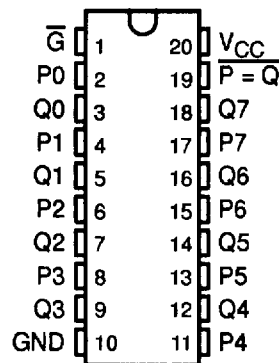

SN54ALS688 ... FK PACKAGE
(TOP VIEW)

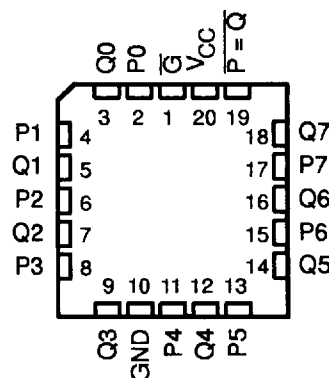

PRODUCTION DATA Information is current as of publication date. Products conform to specifications per the terms of Texas Instruments standard warranty. Production processing does not necessarily include testing of all parameters.



POST OFFICE BOX 655303 • DALLAS, TEXAS 75265

Copyright © 1995, Texas Instruments Incorporated

8961723 0103989 028

SN54ALS688, SN74ALS688 8-BIT IDENTITY COMPARATORS

SDAS228A - JUNE 1982 - REVISED JANUARY 1995

logic symbol†

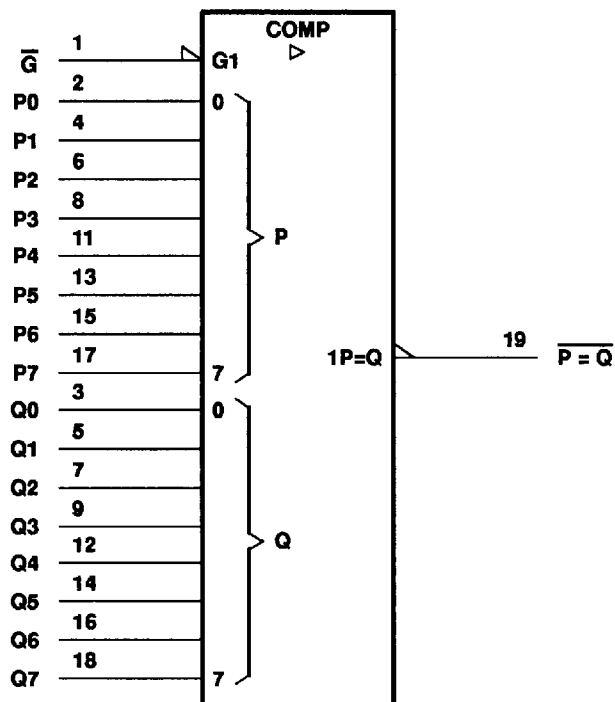

† This symbol is in accordance with ANSI/IEEE Std 91-1984 and IEC Publication 617-12.

logic diagram (positive logic)

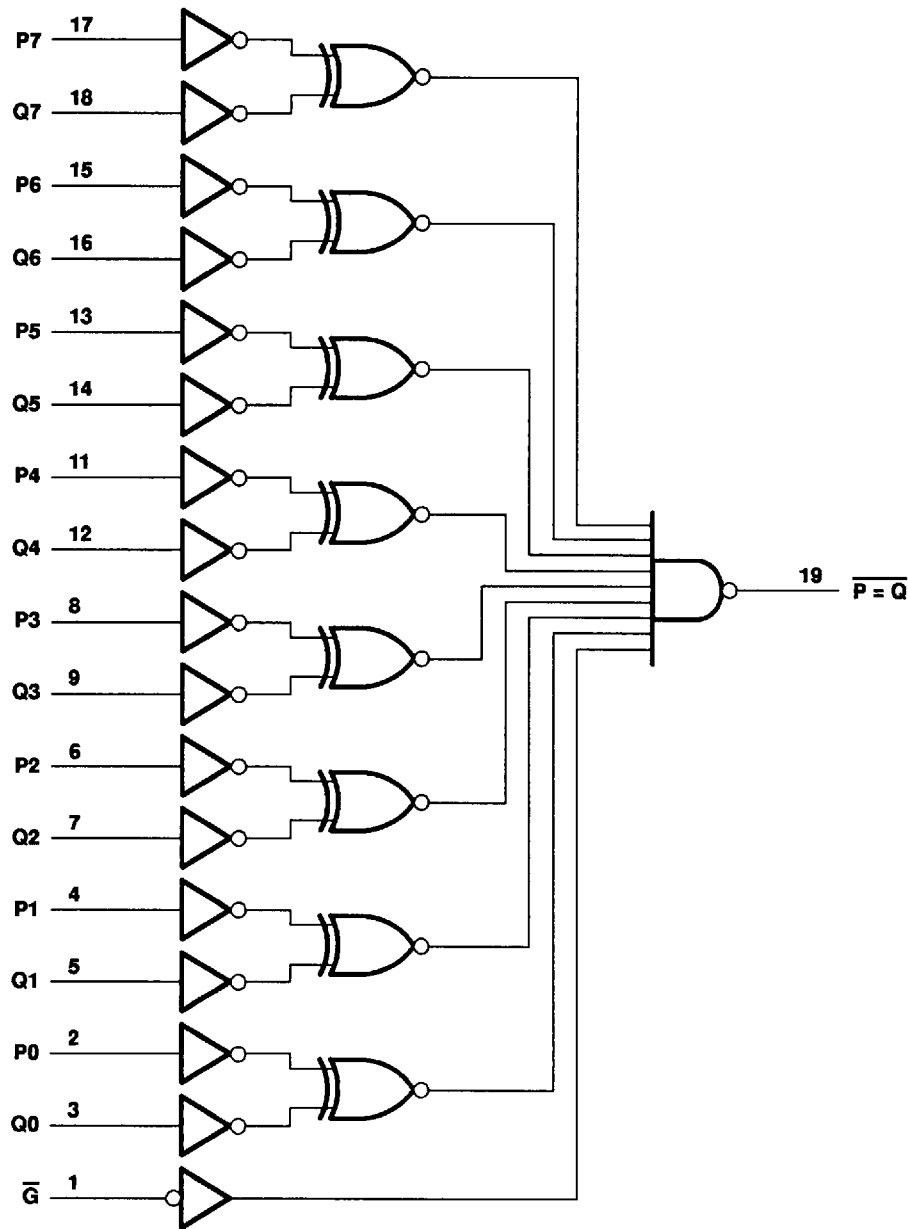

absolute maximum ratings over operating free-air temperature range (unless otherwise noted)†

Supply voltage, V_{CC}	7 V
Input voltage, V_I	7 V
Operating free-air temperature range, T_A : SN54ALS688	-55°C to 125°C
SN74ALS688	0°C to 70°C
Storage temperature range	-65°C to 150°C

† Stresses beyond those listed under "absolute maximum ratings" may cause permanent damage to the device. These are stress ratings only, and functional operation of the device at these or any other conditions beyond those indicated under "recommended operating conditions" is not implied. Exposure to absolute-maximum-rated conditions for extended periods may affect device reliability.

SN54ALS688, SN74ALS688 8-BIT IDENTITY COMPARATORS

SDAS228A - JUNE 1982 - REVISED JANUARY 1995

recommended operating conditions

		SN54ALS688			SN74ALS688			UNIT
		MIN	NOM	MAX	MIN	NOM	MAX	
V _{CC}	Supply voltage	4.5	5	5.5	4.5	5	5.5	V
V _{IH}	High-level input voltage	2			2			V
V _{IL}	Low-level input voltage			0.7			0.8	V
I _{OH}	High-level output current			-1			-2.6	mA
I _{OL}	Low-level output current			12			24	mA
T _A	Operating free-air temperature	-55		125	0		70	°C

electrical characteristics over recommended operating free-air temperature range (unless otherwise noted)

PARAMETER	TEST CONDITIONS	SN54ALS688			SN74ALS688			UNIT
		MIN	TYP†	MAX	MIN	TYP†	MAX	
V _{IK}	V _{CC} = 4.5 V, I _I = -18 mA			-1.5			-1.5	V
V _{OH}	V _{CC} = 4.5 V to 5.5 V, I _{OH} = -0.4 mA	V _{CC} - 2			V _{CC} - 2			V
	V _{CC} = 4.5 V, I _{OH} = -1 mA	2.4	3.3		2.4	3.3		
	V _{CC} = 4.5 V, I _{OH} = -2.6 mA							
V _{OL}	V _{CC} = 4.5 V, I _{OL} = 12 mA		0.25	0.4		0.25	0.4	V
	V _{CC} = 4.5 V, I _{OL} = 24 mA					0.35	0.5	
I _I	V _{CC} = 5.5 V, V _I = 7 V			0.1			0.1	mA
I _{IH}	V _{CC} = 5.5 V, V _I = 2.7 V			20			20	μA
I _{IL}	V _{CC} = 5.5 V, V _I = 0.4 V			-0.1			-0.1	mA
I _{O‡}	V _{CC} = 5.5 V, V _O = 2.25 V	-20		-112	-30		-112	mA
I _{CC}	V _{CC} = 5.5 V, See Note 1		12	19		12	19	mA

† All typical values are at V_{CC} = 5 V, T_A = 25°C.

‡ The output conditions have been chosen to produce a current that closely approximates one half of the true short-circuit output current, I_{OS}.

NOTE 1: I_{CC} is measured with \bar{G} grounded, P and Q at 4.5 V.

switching characteristics (see Figure 1)

PARAMETER	FROM (INPUT)	TO (OUTPUT)	V _{CC} = 4.5 V to 5.5 V, C _L = 50 pF, R _L = 500 Ω, T _A = MIN to MAX§				UNIT
			SN54ALS688		SN74ALS688		
			MIN	MAX	MIN	MAX	
t _{PLH}	P	$\bar{P} = \bar{Q}$	3	16	3	12	ns
t _{PHL}			5	25	5	20	
t _{PLH}	Q	$\bar{P} = \bar{Q}$	3	16	3	12	ns
t _{PHL}			5	25	5	20	
t _{PLH}	\bar{G}	$\bar{P} = \bar{Q}$	3	15	3	12	ns
t _{PHL}			5	25	5	22	

§ For conditions shown as MIN or MAX, use the appropriate value specified under recommended operating conditions.



POST OFFICE BOX 655303 • DALLAS, TEXAS 75265

PARAMETER MEASUREMENT INFORMATION
SERIES 54ALS/74ALS AND 54AS/74AS DEVICES

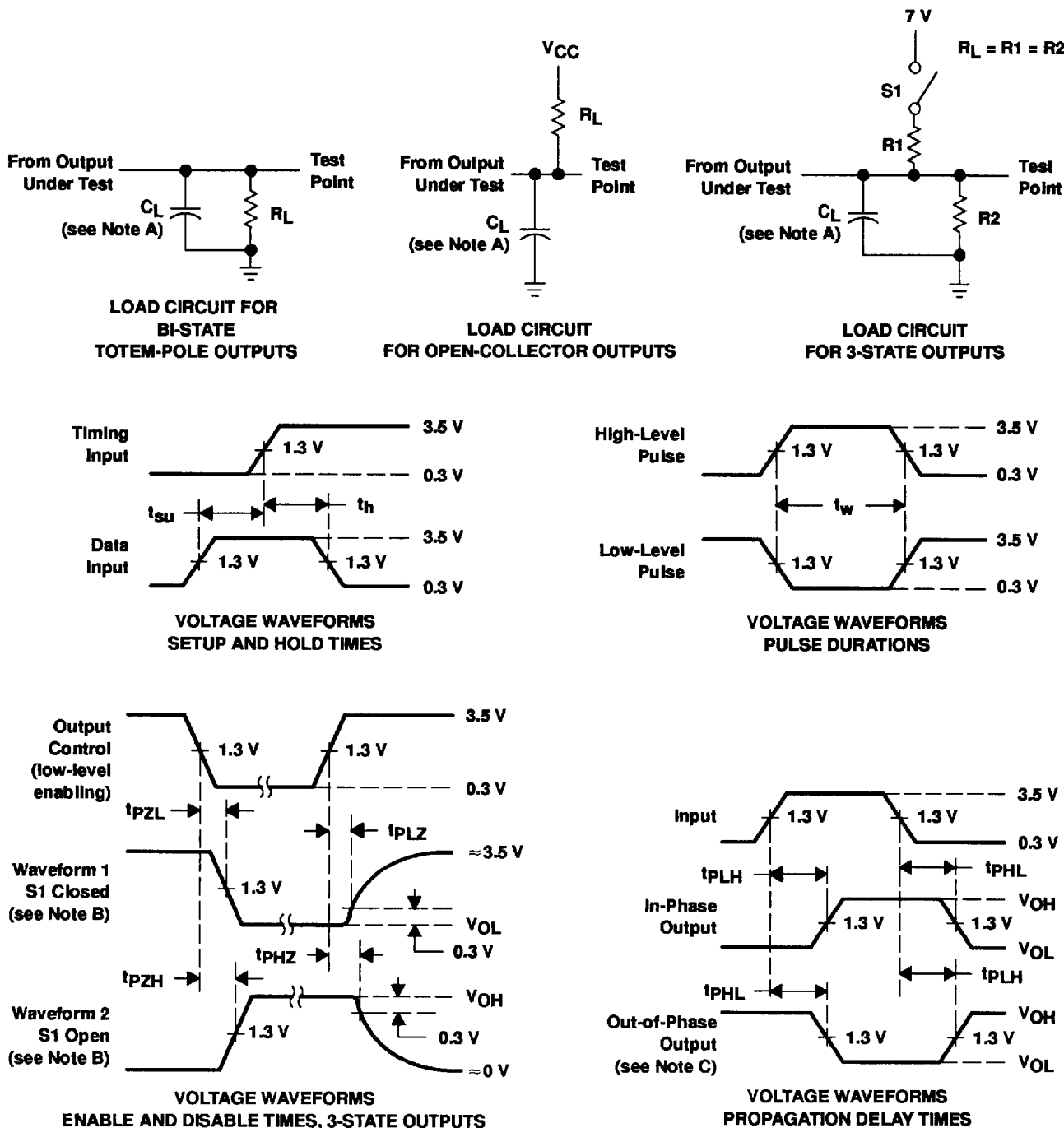

- NOTES: A. C_L includes probe and jig capacitance.
 B. Waveform 1 is for an output with internal conditions such that the output is low except when disabled by the output control. Waveform 2 is for an output with internal conditions such that the output is high except when disabled by the output control.
 C. When measuring propagation delay items of 3-state outputs, switch S1 is open.
 D. All input pulses have the following characteristics: $PRR \leq 1$ MHz, $t_r = t_f = 2$ ns, duty cycle = 50%.
 E. The outputs are measured one at a time with one transition per measurement.

Figure 1. Load Circuits and Voltage Waveforms

