

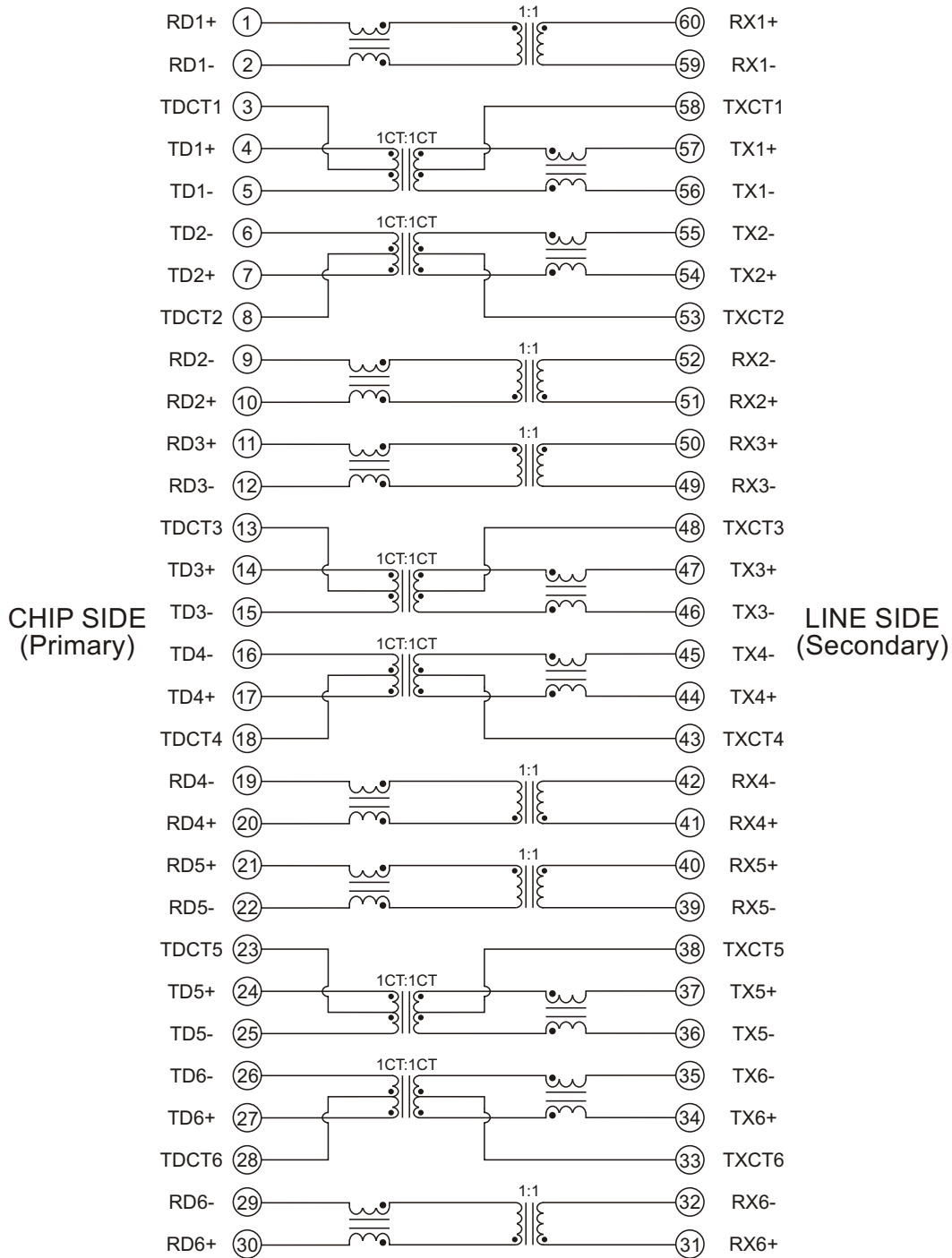

SCHEMATICS

824-M0161





SCHEMATICS

824-M0162

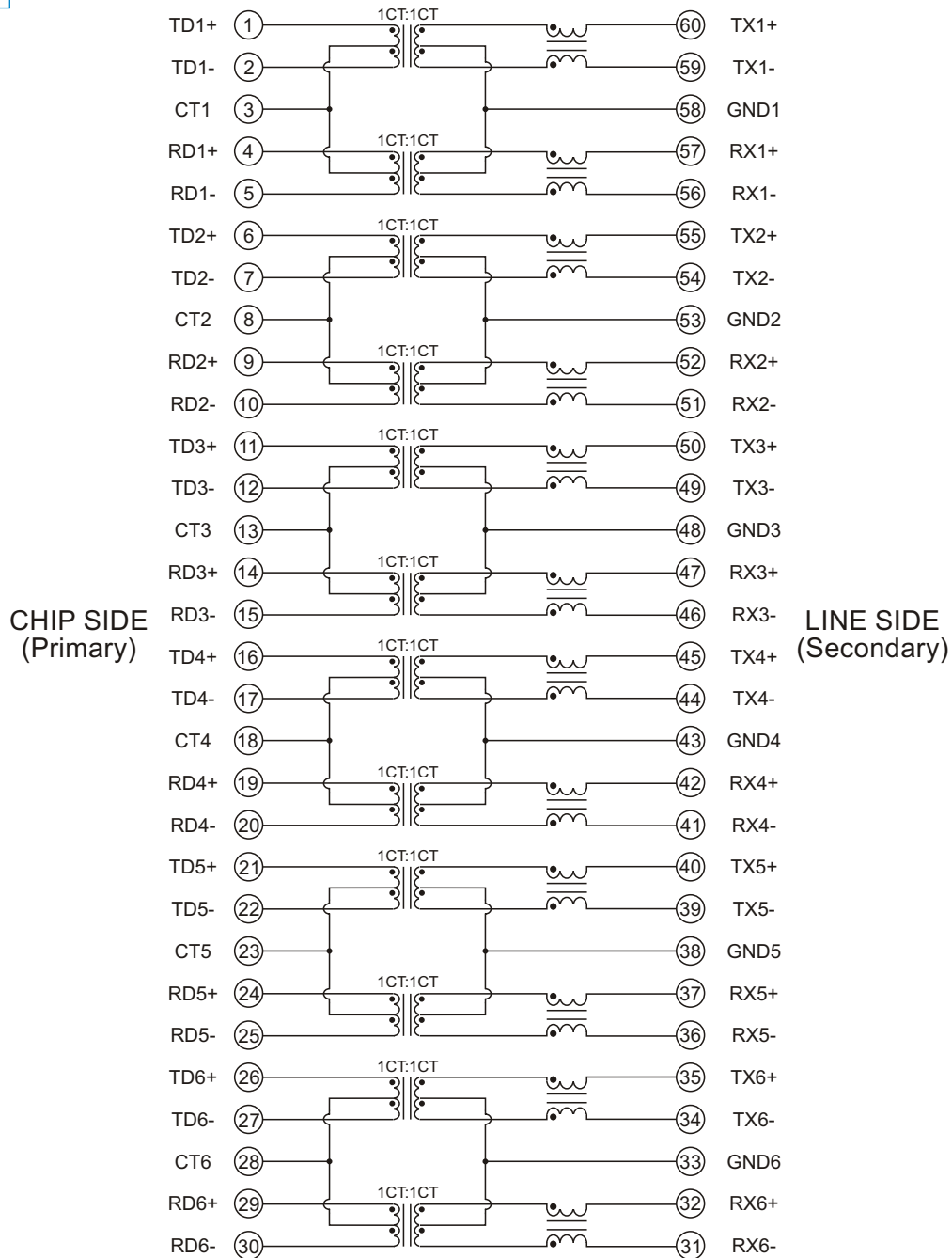

FOR MORE INFORMATION, PLEASE CONTACT

HEADQUARTER
1/F., Harbour View 1, No.12 Science Park East Avenue,
Phase II, Hong Kong Science Park, Shatin, N.T.
Hong Kong
Tel: (852) 2954 3333 Fax: (852) 2954 3304
Email: eempl@eleceltek.com
Website: <http://www.eleceltek.com> / www.eemagnetic.com

Information herein is for reference only and subject to change without notice. It does not constitute any representation, warranty or commitment of the company in respect of the products in any aspect. All logos, brands and product names mentioned herein are trademarks or registered trademarks of their respective owners. The company does not assume any liability arising out of the application or use of any product or circuit described herein. Copyrights 2009, E & E Magnetic Products Limited.