

X3 Frequency Multiplier

50Ω Output 900 to 1200 MHz

ZX90-3-122+



CASE STYLE: JA1242

Connectors Model
SMA ZX90-3-122-S+

+RoHS Compliant

The +Suffix identifies RoHS Compliance. See our web site for RoHS Compliance methodologies and qualifications

Maximum Ratings

Operating Temperature	-40°C to 85°C
Storage Temperature	-55°C to 100°C
RF Input Power	17 dBm

Permanent damage may occur if any of these limits are exceeded.

Coaxial Connections

INPUT	1
OUTPUT	2

Outline Drawing

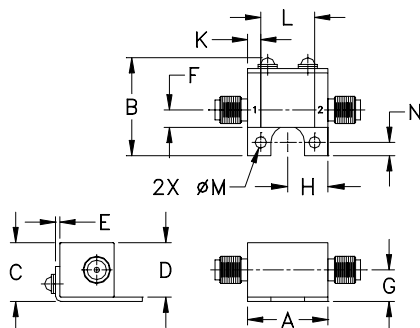

Outline Dimensions (inch/mm)

A	B	C	D	E	F	G
.74	.90	.54	.50	.04	.16	.29
18.80	22.86	13.72	12.70	1.02	4.06	7.37
H	J	K	L	M	N	wt
.37	--	.122	.496	.106	.122	grams
9.40	--	3.10	12.60	2.69	3.10	19.0

Features

- broadband
- low conversion loss, 16 dB typ.
- high rejection F2, and F4, 60 dBc typ.
- rugged construction
- protected by US Patent 6,790,049

Applications

- synthesizers
- local oscillators
- satellite up and down converters

Electrical Specifications

MULTIPLICATION FACTOR	FREQUENCY (MHz)		INPUT POWER (dBm)		CONVERSION LOSS (dB)		*HARMONIC OUTPUT (dBc)					
	F1 Input	F3 Output	Min.	Max.	Typ.	Max.	F1		F2		F4	
	Typ.	Min.	Typ.	Min.	Typ.	Min.	Typ.	Min.	Typ.	Min.	Typ.	Min.
3	300-400	900-1200	0	6	16	20	48	30	60	40	70	40

* Harmonics of input frequency below the power level of F3

Typical Performance Data

Input Frequency (MHz)	INPUT RF= 0 dBm				INPUT RF= 6 dBm			
	Conversion Loss (dB)	Harmonic Output Below F3 (-dBc)			Conversion Loss (dB)	Harmonic Output Below F3 (-dBc)		
		F3	F1	F2		F4	F3	F1
300.00	15.55	43.51	79.89	80.52	17.42	45.52	81.95	72.85
310.00	15.10	47.58	75.44	79.10	17.39	49.03	77.10	71.02
320.00	14.47	50.59	70.39	74.60	17.77	50.71	71.34	71.10
330.00	14.39	52.21	65.30	73.18	17.98	51.42	65.77	72.36
340.00	14.34	53.26	64.86	75.14	17.71	51.87	66.11	74.56
350.00	14.55	53.38	66.15	78.09	17.68	51.50	68.14	75.95
360.00	15.11	52.27	66.02	84.26	17.52	50.82	68.51	82.88
370.00	15.65	50.80	64.82	95.71	17.21	50.16	67.63	92.89
380.00	15.96	49.50	64.04	101.73	17.07	49.60	66.84	102.37
390.00	16.13	48.27	63.93	100.52	17.31	49.10	66.70	101.15
400.00	16.35	46.82	64.25	100.80	17.99	48.05	67.56	96.71

ZX90-3-122+ CONVERSION LOSS

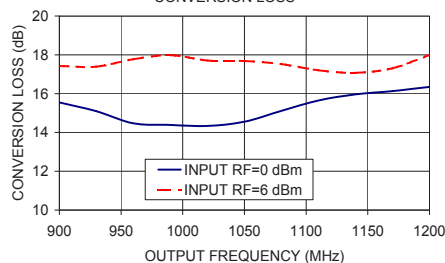

ZX90-3-122+ HARMONIC OUTPUT F1

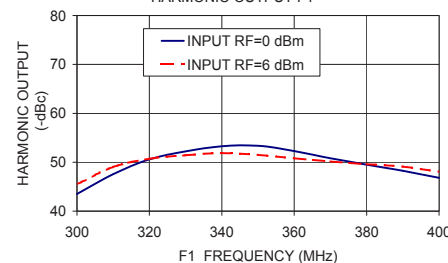

ZX90-3-122+ HARMONIC OUTPUT F2

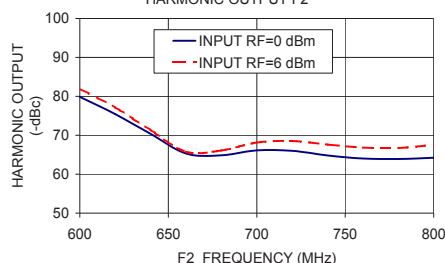

ZX90-3-122+ HARMONIC OUTPUT F4

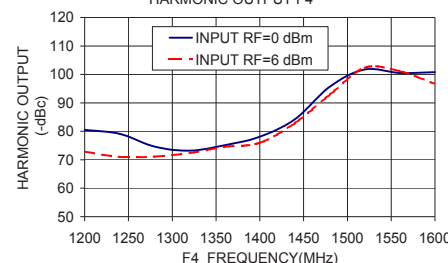

Notes

- Performance and quality attributes and conditions not expressly stated in this specification document are intended to be excluded and do not form a part of this specification document.
- Electrical specifications and performance data contained in this specification document are based on Mini-Circuit's applicable established test performance criteria and measurement instructions.
- The parts covered by this specification document are subject to Mini-Circuits standard limited warranty and terms and conditions (collectively, "Standard Terms"); Purchasers of this part are entitled to the rights and benefits contained therein. For a full statement of the Standard Terms and the exclusive rights and remedies thereunder, please visit Mini-Circuits' website at www.minicircuits.com/MCLStore/terms.jsp



Frequency Multiplier (Tripler)

ZX90-3-122+

Typical Performance Data

FREQUENCY (MHz)				RF IN=+0dBm			
				CONVERSION LOSS (dB)	HARMONIC OUTPUT* (-dBc)		
X1 OUTPUT	X2 OUTPUT	X3 OUTPUT	X4 OUTPUT	X3 OUTPUT	X1 OUTPUT	X2 OUTPUT	X4 OUTPUT
300.00	600.00	900.00	1200.00	15.55	43.51	79.89	80.52
310.00	620.00	930.00	1240.00	15.10	47.58	75.44	79.10
320.00	640.00	960.00	1280.00	14.47	50.59	70.39	74.60
330.00	660.00	990.00	1320.00	14.39	52.21	65.30	73.18
340.00	680.00	1020.00	1360.00	14.34	53.26	64.86	75.14
350.00	700.00	1050.00	1400.00	14.55	53.38	66.15	78.09
360.00	720.00	1080.00	1440.00	15.11	52.27	66.02	84.26
370.00	740.00	1110.00	1480.00	15.65	50.80	64.82	95.71
380.00	760.00	1140.00	1520.00	15.96	49.50	64.04	101.73
390.00	780.00	1170.00	1560.00	16.13	48.27	63.93	100.52
400.00	800.00	1200.00	1600.00	16.35	46.82	64.25	100.80

* Harmonic Output below power level of X3 Output.

FREQUENCY (MHz)				RF IN=+6dBm			
				CONVERSION LOSS (dB)	HARMONIC OUTPUT* (-dBc)		
X1 OUTPUT	X2 OUTPUT	X3 OUTPUT	X4 OUTPUT	X3 OUTPUT	X1 OUTPUT	X2 OUTPUT	X4 OUTPUT
300.00	600.00	900.00	1200.00	17.42	45.52	81.95	72.85
310.00	620.00	930.00	1240.00	17.39	49.03	77.10	71.02
320.00	640.00	960.00	1280.00	17.77	50.71	71.34	71.10
330.00	660.00	990.00	1320.00	17.98	51.42	65.77	72.36
340.00	680.00	1020.00	1360.00	17.71	51.87	66.11	74.56
350.00	700.00	1050.00	1400.00	17.68	51.50	68.14	75.95
360.00	720.00	1080.00	1440.00	17.52	50.82	68.51	82.88
370.00	740.00	1110.00	1480.00	17.21	50.16	67.63	92.89
380.00	760.00	1140.00	1520.00	17.07	49.60	66.84	102.37
390.00	780.00	1170.00	1560.00	17.31	49.10	66.70	101.15
400.00	800.00	1200.00	1600.00	17.99	48.05	67.56	96.71

* Harmonic Output below power level of X3 Output.



P.O. Box 350186, Brooklyn, New York 11235-0003 (718) 934-4500 Fax (718) 332-4661 For detailed performance specs & shopping online see Mini-Circuits web site



The Design Engineers Search Engine Provides ACTUAL Data Instantly From MINI-CIRCUITS At: www.minicircuits.com

RF/IF MICROWAVE COMPONENTS

REV. X1
ZX90-3-122+
8/18/2008
Page 1 of 1

Typical Performance Curves

Conversion Loss X3 Output

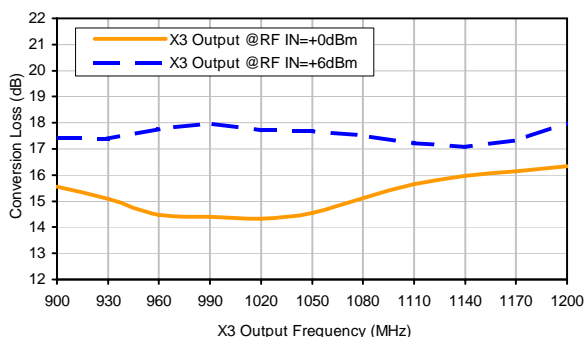

Harmonic X1 Output

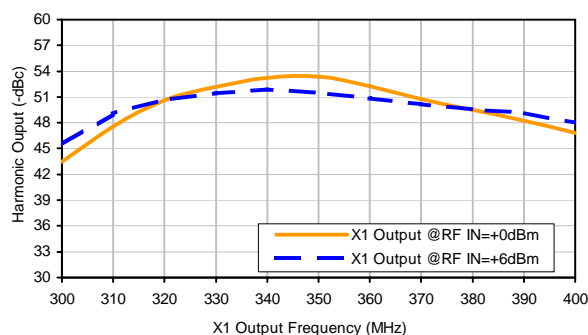

Harmonic X2 Output

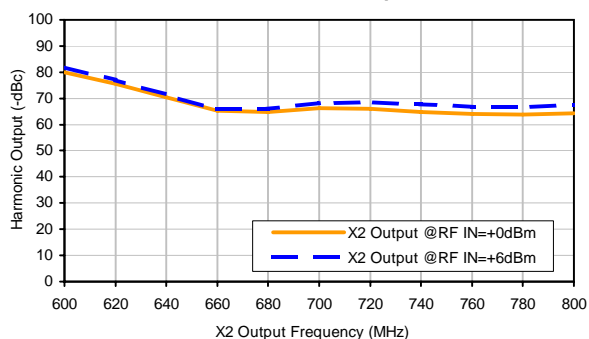

Harmonic X4 Output

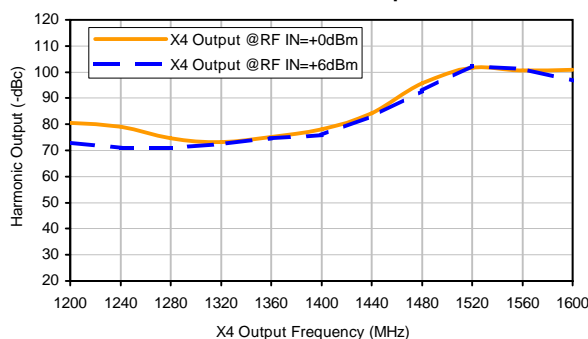

Outline Dimensions

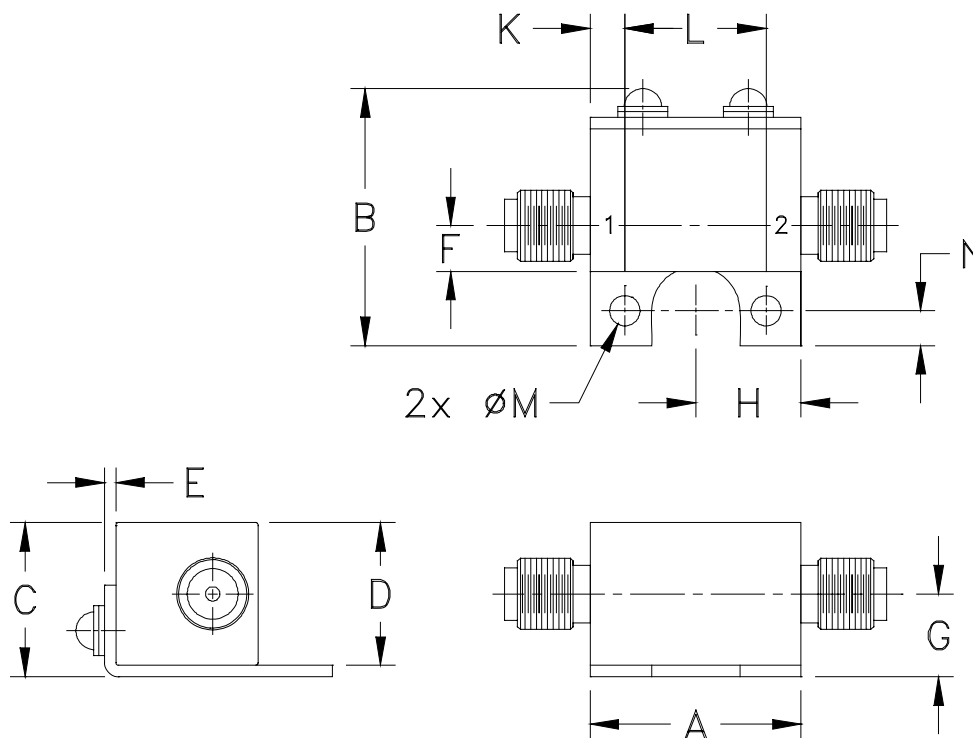

CASE #.	A	B	C	D	E	F	G	H	J	K	L	M	N	WT, GRAM
JA1242	.74 (18.80)	.90 (22.86)	.54 (13.72)	.50 (12.70)	.04 (1.02)	.16 (4.06)	.29 (7.37)	.37 (9.40)	- -	.122 (3.10)	.496 (12.60)	.106 (2.69)	.122 (3.10)	19.0

**Dimensions are in inches (mm). Tolerances: 2Pl. $\pm .03$; 3Pl. $\pm .015$.
Tolerance on hole size and interaxes dimensions to be $\pm .005$.**

Notes:

1. Case material: Brass.
2. Case finish: Nickel plate.

Mini-Circuits®

Distribution Centers NORTH AMERICA 800-654-7949 • 417-335-5935 • Fax 417-335-5945 • EUROPE 44-1252-832600 • Fax 44-1252-837010

Mini-Circuits ISO 9001 & ISO 14001 Certified

INTERNET <http://www.minicircuits.com>

P.O. Box 350166, Brooklyn, New York 11235-0003 (718) 934-4500 Fax (718) 332-4661



All Mini-Circuits products are manufactured under exacting quality assurance and control standards, and are capable of meeting published specifications after being subjected to any or all of the following physical and environmental test.

Specification	Test/Inspection Condition	Reference/Spec
Operating Temperature	-40° to 85°C	Individual Model Data Sheet
Storage Temperature	-55° to 100° C Ambient Environment	Individual Model Data Sheet
Barometric Pressure	100,000 Feet	MIL-STD-202, Method 105, Condition D
Humidity	90% RH, 65°C Units may require bake-out after humidity to restore full performance.	MIL-STD-202, Method 103
Thermal Shock	-65° to 125°C, 5 cycles	MIL-STD-202, Method 107, Condition B
Vibration (High Frequency)	20g peak, 10-2000 Hz, 12 times in each of three perpendicular directions (total 36)	MIL-STD-202, Method 204, Condition D
Mechanical Shock	100g, 6ms sawtooth, 3 shocks each direction 3 axes (total 18)	MIL-STD-202, Method 213, Condition I