

REVISIONS			
REV.	DESCRIPTION	ECN NO.	DATE
01	FIRST RELEASE	N/A	03/11/09

PAGE 4 IS FOR INTERNAL ONLY

PART NUMBER		PART DESCRIPTION		TITLE											
835-01093F		RoHS compliant per EU Directive 2002/95/EC(without exemption of solder content)		TRANSFORMER, FLYBACK, SMT, 12 PIN											
<p align="center">WARNING !</p> <p>ALL SHEETS OF THIS DOCUMENT ARE CONTROLLED DOCUMENTATION AND ARE NOT TO BE RELEASED OUTSIDE OF E&E OR ITS SUB-CONTRACTORS WITHOUT AUTHORIZATION.</p>		UNLESS OTHERWISE SPECIFIED, DIMENSIONS ARE IN INCH/mm.		APPROVALS											
		<p align="center">TOLERANCE ARE:</p> <table border="0"> <tr> <td>INCH</td> <td>mm</td> <td>ANGLE</td> </tr> <tr> <td>.XXX ± .005</td> <td>.XX ± .13</td> <td>X.X ± 0.3</td> </tr> <tr> <td>.XX ± .02</td> <td>.X ± .5</td> <td>X. ± 1</td> </tr> </table>		INCH	mm	ANGLE	.XXX ± .005	.XX ± .13	X.X ± 0.3	.XX ± .02	.X ± .5	X. ± 1	DATE		 <p>E & E Magnetic Products Ltd.</p>
		INCH	mm	ANGLE											
		.XXX ± .005	.XX ± .13	X.X ± 0.3											
		.XX ± .02	.X ± .5	X. ± 1											
DRAWN BY		03/11/09		DRAWING NO./MODEL											
W.P. CHENG		03/11/09													
PROJ. ENG		03/11/09		REV											
W.P. CHENG		03/11/09													
APPROVED BY		03/11/09		835-01093F											
V. TSUI		03/11/09													
Q.A.		03/11/09		SCALE											
C.M. TSUI		03/11/09													
				DO NOT SCALE											
				PAGE 1 OF 4											

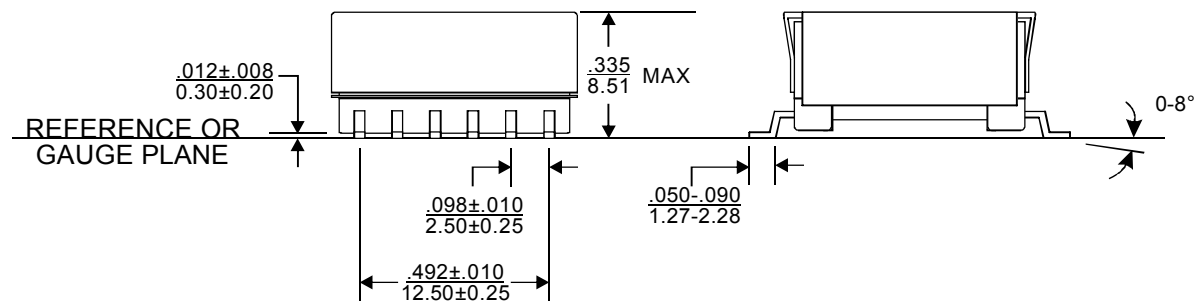
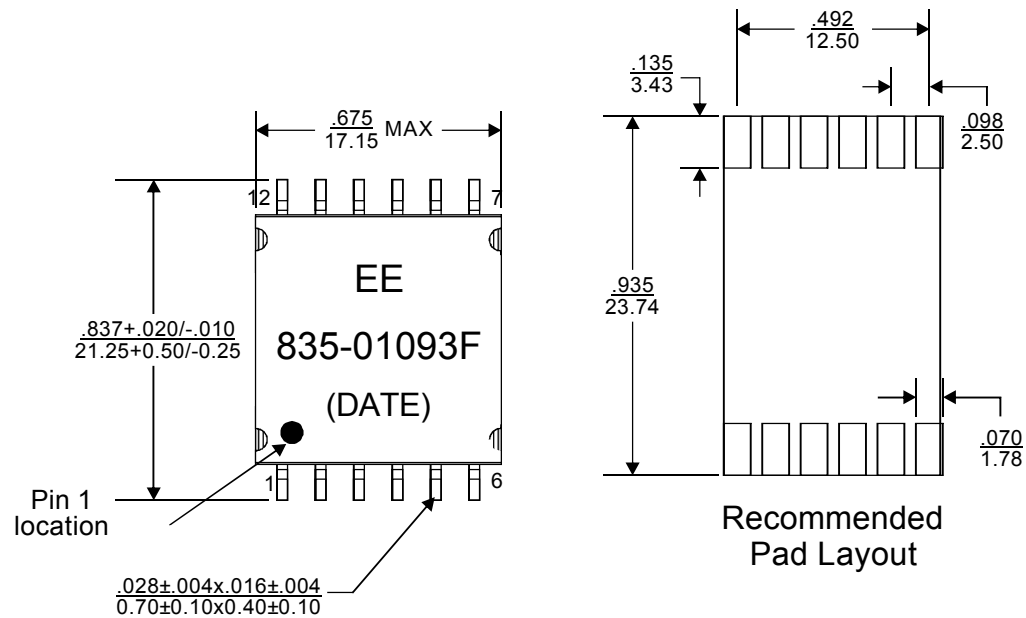

1. Dimension are specified in $\frac{\text{inches}}{\text{mm}}$ with higher precedence in inches.
2. Unless otherwise specified, all tolerances are $\pm \frac{.010}{0.25}$.
3. Coplanarity: $\frac{.004}{0.10}$ max.
4. "(DATE)" includes at least the manufacturing date code(in YYWW format) plus two character country code.
5. Dimensions are to be measured in accordance with JEDEC standard 95-1.

MECHANICAL OUTLINE



E & E Magnetic Products Ltd.

DRAWING NO./MODEL		REV	
835-01093F		01	
SCALE	PAGE	OF	
DO NOT SCALE	2	4	

ELECTRICAL SPECIFICATION @25°C:

PARAMETERS	UNIT	LIMITS
Turns Ratio(pri):(sec)	-	5.0 : 1 ± 2%
Turns Ratio(pri):(drive)	-	3.2 : 1 ± 2%
Turns Ratio(pri):(bias)	-	2.25 : 1 ± 2%
Polarity	-	Per Schematic
DCR(pri)	Ω	0.520 Max
DCR(sec)	Ω	0.0275Max
DCR(drive)	Ω	0.525 Max
DCR(bias)	Ω	0.770 Max
Inductance, Ls(pri)@100kHz, 0.1Vrms	uH	150 ± 10%
Inductance, Ls(pri)@100kHz, 0.1Vrms, 1.2Adc	uH	135 Min
LL(pri), short sec+drive@100kHz, 0.1Vrms	uH	2.0 Max
LL(drive), short sec@100kHz, 0.1Vrms	uH	0.4 Max
HIPOT(pri+bias):(sec+drive)	Vrms	1500 Min

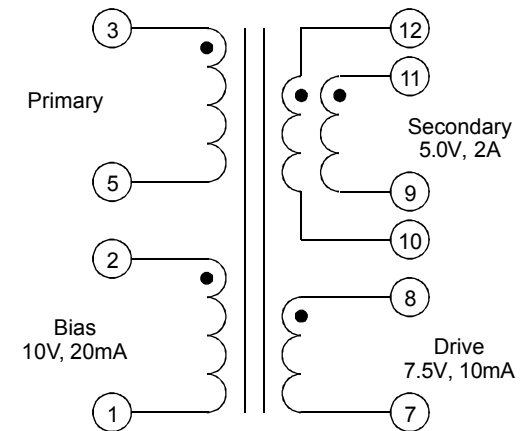

SCHEMATIC

- Operating temperature: -40°C to +125°C. The part temperature (ambient temperature + temperature rise) should not exceed the upper limit of the operating temperature under worst case operating conditions. Circuit design, component placement, PWB trace size and thickness, airflow and other cooling provisions all affect the part temperature. Part temperature should be verified in the end application.
- The secondary windings are to be connected in parallel on the PC board. DCR for secondary is with windings connected in parallel. Turns ratio is with both secondary windings connected in parallel.
- Secondary output: 5.0V, 2A, Drive output: 7.5V, 10mA. Output of the secondary is with the windings connected in parallel. 10W output from 36 - 72 V PoE input or 24V adapter; 6W output from 12V adaptor. Bias winding output is 10V, 20mA.



E & E Magnetic Products Ltd.

DRAWING NO./MODEL

835-01093F

REV

01

SCALE

DO NOT SCALE

PAGE

3

OF

4