

	5		4		3		2		1
PART NUMBER	ITEM ① CONTACT	ITEM ② SPRING	ITEM ③ BODY	ITEM ④ INSULATOR	ITEM ⑤ BODY				
25-7141	BRASS NICKEL PLATED	STEEL NICKEL PLATED	BRASS NICKEL PLATED	DELRIN	ZINC NICKEL PLATED				

**受控 CONTROLLED DOCUMENT**

编号 P/N	25-7141	版本 Rev	0B	日期 Rel'd Date	Mar 24,08
-----------	---------	-----------	----	------------------	-----------

DRAWING NO. 25-7141	
REVISIONS	
RELEASE FOR QUOTATION	
A	05-20-06 W W T
CHANGE TOLERANCE ON OVERALL LENGTH AND ADD 4, 5 NOTES.	
B	12-18-06 W G T

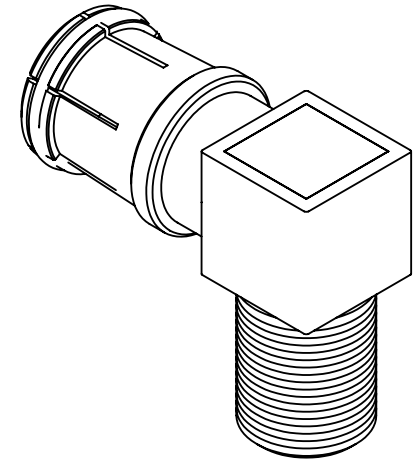
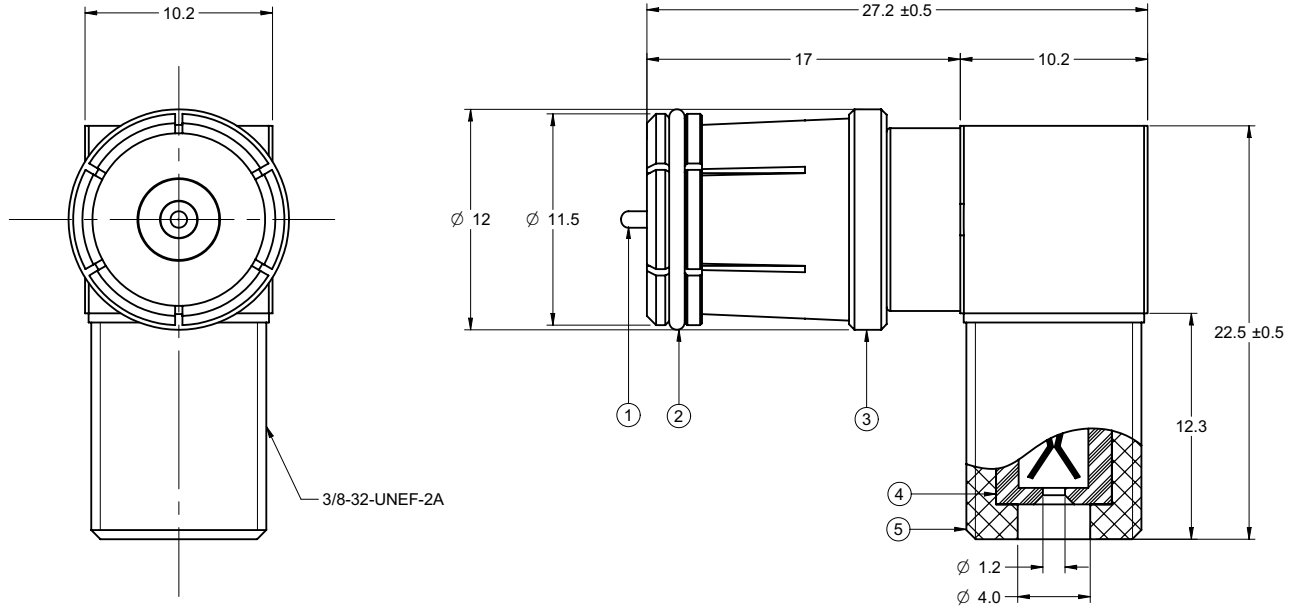

- NOTES:
- ELECTRICAL SPECIFICATIONS  
 IMPEDANCE: 75 OHM  
 WORKING VOLTAGE: 500 VOLTS RMS AT SEA LEVEL  
 DIELECTRIC WITHSTANDING VOLTAGE: 1500 VOLTS RMS AT SEA LEVEL  
 INSULATION RESISTANCE: 5000 MEGOHMS MIN
  - ENVIRONMENTAL SPECIFICATIONS  
 TEMPERATURE RANGE: -55°C TO +85°C
  - MECHANICAL CHARACTERISTICS:  
 DURABILITY: 500 CYCLES
  - PRODUCT SHOULD BE RoHS COMPLIANCE.
  - PACKAGING REQUIREMENT FOLLOWS ENGINEERING DOCUMENT P/N 836-4020000XX.

THIS DRAWING TO BE INTERPRETED PER ANSI Y 14.5M - 1994  
**COMPANY CONFIDENTIAL**

TOLERANCE UNLESS OTHERWISE SPECIFIED		DRAWN BY LINDA.WU	DATE 12-18-06
DECIMALS	mm	CHECKED BY BETTY.YU	DATE 12-18-06
X	± 0.5	APPROVED BY THOMAS	DATE 12-18-06
X.X	± 0.2	U/M	mm
X.XX	± 0.1		
ANGLES	± 0.5°		

**EMERSON**  
Network Power

**Connectivity Solutions**

TITLE  
RT.ANGLE F FM. TO PUSH ON MALE

SHEET 1 OF 1	DRAWING NO. 25-7141	SIZE C
-----------------	------------------------	-----------

THIS DRAWING WAS PRODUCED BY COMPUTER, DO NOT SCALE DRAWING OR UPDATE MANUALLY.