

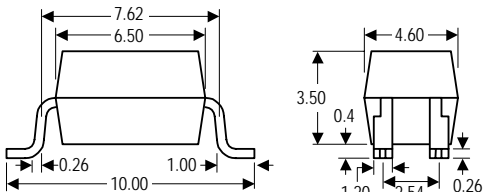

# SFH6286/2/3/4 TRANSISTOR AC INPUT OPTOCOUPLEDERS

**ISOCOM**® LTD

PACKAGES	CIRCUIT
	

## DESCRIPTION

The SFH6286/2/3/4 is a bi-directional input opto-isolator consists of two Gallium Arsenide infrared emitting diodes connected in inverse parallel coupled to a silicon NPN phototransistor in a 4 pin package.

Isocom Ltd supplies a multitude of plastic optocouplers for all applications varying from standard transistor optos through to Darlington and Schmitt Trigger devices. It's massive family of optos vary in speed allowing maximum opportunity to engineers worldwide.

All devices are performance guaranteed between -20°C and +80°C and have completed rigorous testing. The Company's customers can be assured of our commitment to stringent quality, reliability and inspection standards, as demonstrated by our existing approvals. Other customer specific options can also be offered.

## FEATURES

- 5300V RMS Isolation
- AC or Polarity Insensitive Inputs
- Compact Dual-in-line Package
- Built-in Reverse polarity Input Protection
- Current Transfer Ratio (Min 50% at  $I_F = \pm 1\text{mA}$ ,  $V_{CE} = 5\text{V}$ )
- UL Recognised, file No 250824

Isocom Ltd reserves the right to change the details on this specification without notice. Please consult Isocom Ltd prior to use. Isocom Ltd cannot accept liability for any errors or omissions.

For sales enquiries, or further information, please contact our sales office at:

Isocom Ltd, Hutton Close, Crowther Industrial Estate, District 3, Washington, NE38 0AH

Tel: +44 0191 4166 546 Fax: +44 0191 4155 055 Email [Isocom@isocomptocouplers.com](mailto:Isocom@isocomptocouplers.com)

Or go to the Isocom Website @: [Http://www.isocom.uk.com](http://www.isocom.uk.com)

## ABSOLUTE MAXIMUM RATINGS

Storage Temperature	-55°C to +125°C
Operating Temperature	-30°C to +100°C
Lead Soldering Temperature	260°C 1.6mm from case for 10S
Input-to-Output Isolation Voltage	5000VDC

### Input Diode

Forward DC Current	±50mA	
Peak forward Current	±1.0A	
Power Dissipation	70mW	

### Output Transistor

Collector-Emitter Voltage	55V	$BV_{CEO}$
Emitter-Collector voltage	6V	$BV_{ECO}$
Collector-Current	50mA	$I_C$
Collector Power Dissipation	150mW	$P_C$

### Package

Total Power Dissipation	200mW	$P_{tot}$
-------------------------	-------	-----------

## ELECTRICAL CHARACTERISTICS

$T_A = 25^\circ\text{C}$  U.O.S. (each channel where appropriate).

### Input Diode Electrical Characteristics

Parameter	Symbol	Test Conditions	Device	Min	Typ	Max	Units
Forward Voltage	$V_F$	$I_F = \pm 20\text{mA}$			1.2	1.4	V
Peak Forward Voltage	$V_{FM}$	$I_{FM} = \pm 0.5\text{A}$				3.0	V
Terminal Capacitance	$C_t$	$V = 0, f = 1\text{KHz}$			50	250	pF

### Output Detector Electrical Characteristics

Collector-emitter Dark Current	$I_{CEO}$	$V_{CE} = 20\text{V}, I_F = 0$				$10^{-7}$	A
--------------------------------	-----------	--------------------------------	--	--	--	-----------	---

### Coupled Electrical Characteristics

Current Transfer ratio	CTR	$I_F = \pm 10\text{mA}, V_{CE} = 5\text{V}$ SFH6286-2 SFH6286-3 SFH6286-4		60 100 160		200 320 600	%
Collector-Emitter saturation voltage	$V_{CE(sat)}$	$I_F = \pm 20\text{mA}, I_C = 1\text{mA}$			0.1	0.2	V
Isolation Resistance	$R_{ISO}$	DC= 5300V, 40 to 60% RH		$5 \cdot 10^{10}$	$10^{11}$		$\Omega$
Floating Capacitance	$C_f$	$V = 0, f = 1\text{Mhz}$			0.6	1.0	pF
Cut-off Frequency	$f_c$	$V_{CE} = 5\text{V}, I_C = 2\text{mA}, R_L = 100\Omega$		15	80		KHz
Response time (Rise)	$t_r$	$V_{CC} = 2\text{V}, I_C = 2\text{mA}, R_L = 100\Omega$			4	18	$\mu\text{S}$
Response time (Fall)	$t_f$				3	18	$\mu\text{S}$
Isolation Voltage	$V_{ISO}$			5300			Vrms

Isocom Ltd reserves the right to change the details on this specification without notice. Please consult Isocom Ltd prior to use.

Isocom Ltd cannot accept liability for any errors or omissions.

For sales enquiries, or further information, please contact our sales office at:

Isocom Ltd, Hutton Close, Crowther Industrial Estate, District 3, Washington, NE38 0AH

Tel: +44 0191 4166 546 Fax: +44 0191 4155 055 Email [Isocom@isocomptocouplers.com](mailto:Isocom@isocomptocouplers.com)

Or go to the Isocom Website @: [Http://www.isocom.uk.com](http://www.isocom.uk.com)