

July 1997

800MHz, Ultra High-Speed Monolithic Pin Driver

Features

- High Digital Data Rate 800MHz
- Very Fast Rise/Fall Times 500ps
- Wide Output Range +8V to -3V
- Precise 50Ω Output Impedance
- High Impedance, Three-State Output Control
- Slew Rate Control

Applications

- IC Tester Pin Electronics
- Pattern Generators
- Pulse Generators
- Level Comparator/Translator

Ordering Information

PART NUMBER	TEMP. RANGE (°C)	PACKAGE	PKG. NO.
HFA5253CB	0 to 50	20 Ld PSOP	M20.3A
HFA5253Y	T _{JUNCTION} < 175	Die Form	N/A

Description

The HFA5253 is a very high speed monolithic pin driver solution for high performance test systems. The device will switch at high data rates between two input voltage levels providing variable amplitude pulses. Slew Rate Control pins provide independent control over positive and negative slew rate allowing the customer to optimize the pin driver speed for their application. The output impedance is trimmed to achieve a precision 50Ω source for impedance matching. Two differential ECL/TTL compatible inputs control the operation of the HFA5253, one controlling the V_{HIGH}/V_{LOW} switching and the other controlling the output's high-impedance state. The HFA5253's 800MHz data rate makes it compatible with today's high-speed VLSI test systems and the +8V to -3V output swing satisfies the most stringent testing requirements of all common logic families.

The HFA5253 is manufactured in Harris' proprietary complementary bipolar UHF-1 process.

Pinout

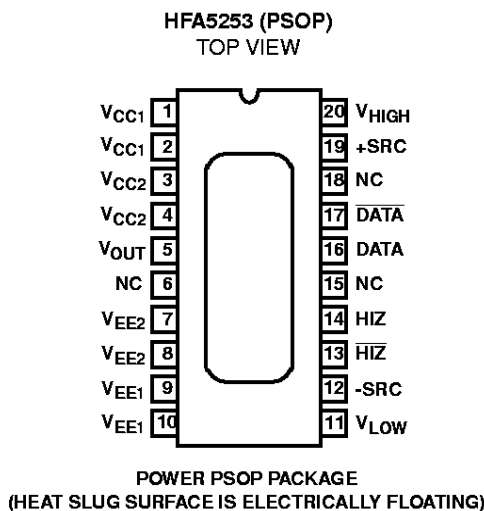

Block Diagram

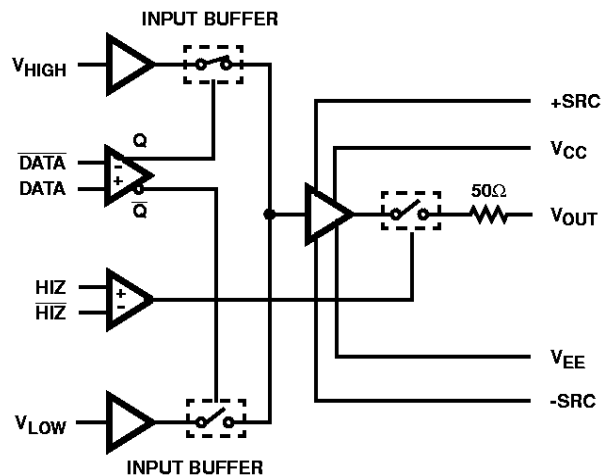

TRUTH TABLE FOR V_{OUT}

		DATA	
		0	1
HIZ	0	V _{LOW}	V _{HIGH}
	1	HIZ	HIZ

Pin Descriptions

NAME	FUNCTION
V _{CC1}	Positive Supply. Nominal value is 11.2V ±0.2V. Reducing supply voltage below 11.0V will reduce positive output voltage swing. The total supply voltage from V _{CC1} to V _{EE1} should not exceed 18.0V for normal operation or exceed 19.0V to prevent damage. Harris recommends two wire bonds to this pad to provide the lowest possible impedance. In addition, power supply decoupling chip capacitors of 470pF, 0.1μF and a 10μF tantalum are recommended. Do not connect the V _{CC1} and V _{CC2} pins together immediately, rather run separate traces until they can be joined at a large by-pass capacitor (0.1μF 10.0μF).
V _{EE1}	Negative Supply. Nominal value is -6.4V ±0.2V. A supply voltage more positive than -6.2V will reduce negative output voltage swing. The total supply voltage from V _{CC1} to V _{EE1} should not exceed 18.0V for normal operation or exceed 19.0V to prevent damage. Harris recommends two wire bonds to this pad to provide the lowest possible impedance. In addition, power supply decoupling chip capacitors of 470pF, 0.1μF and a 10μF tantalum are recommended. Do not connect the V _{EE1} and V _{EE2} pins together immediately, rather run separate traces until they can be joined at a large by-pass capacitor (0.1μF 10.0μF).
V _{CC2}	Output Stage Positive Supply. Nominal voltage and cautions are the same as for V _{CC1} . Having decoupling chip capacitors close to V _{CC2} and V _{EE2} is essential since large AC current will flow through this pad to the output during transients. Harris recommends two wire bonds for this pad. Do not connect the V _{CC1} and V _{CC2} pins together immediately, rather run separate traces until they can be joined at a large by-pass capacitor (0.1μF 10.0μF).
V _{EE2}	Output Stage Negative Supply. Nominal voltage and cautions are the same as for V _{EE1} . Having decoupling chip capacitors close to V _{CC2} and V _{EE2} is essential since large AC current will flow through this pad to the output during transients. Harris recommends two wire bonds for this pad. Do not connect the V _{EE1} and V _{EE2} pins together immediately, rather run separate traces until they can be joined at a large by-pass capacitor (0.1μF 10.0μF).
V _{HIGH}	Input Voltage High is used to set the output high level V _{OH} . V _{HIGH} is sensitive to capacitively coupled AC noise. Protection from high frequency noise can be achieved with a low pass filter consisting of a 50Ω chip resistor and a 470pF chip capacitor. Without this precaution the pin driver may oscillate due to feedback from the output through the PC board ground.
V _{LOW}	Input Voltage Low is used to set the output low level V _{OL} . V _{LOW} is sensitive to capacitively coupled AC noise. Protection from high frequency noise can be achieved with a low pass filter consisting of a 50Ω chip resistor and a 470pF chip capacitor. Without this precaution the pin driver may oscillate due to feedback from the output through the PC board ground.
V _{OUT}	Driver Output. The output impedance has been laser trimmed to match a 50Ω transmission line ±2Ω. Custom output impedance trimming is available (contact sales office for details) to provide the best match possible to your 50Ω system.
$\overline{\text{DATA}}$, DATA	Differential Digital Inputs used to switch V _{OUT} to the V _{HIGH} or V _{LOW} level. Harris recommends this input pair be driven by complementary ECL signals to provide optimal switching speeds and timing accuracy. However a large Common Mode and Differential Voltage Range is provided to accommodate a variety of signals including single ended TTL and CMOS. When using single ended signals the other input must be tied to an appropriate threshold voltage.
HIZ, HIZ	Differential Digital Inputs used to switch V _{OUT} from an Active to a High Impedance State. Harris recommends that this input pair be driven by complementary ECL signals to provide optimal switching speeds and timing accuracy. However a large Common Mode and Differential Voltage Range is provided to accommodate a variety of signals including single ended TTL and CMOS. When using single ended signals the other input must be tied to an appropriate threshold voltage.
+SRC	The Positive Slew Rate Control Pin adjusts the rising edge slew rate with an external current I _{STEAL} . I _{STEAL} draws current (0mA to 10mA) from an internal current source limiting the rate of change of the high impedance node. Typically an external resistor to GND is sufficient to set the slew rate at a desired level. Leaving the +SRC Pin open will give the highest speed performance. The external current I _{STEAL} for a resistor R _{STEAL} connected from +SRC to GND may be calculated by: $I_{STEAL} = (V_{CC} - 0.35)/R_{STEAL}$.
-SRC	The Negative Slew Rate Control Pin adjusts the falling edge slew rate with an external current I _{STEAL} . I _{STEAL} supplies current (0mA to 10mA) to an internal current source limiting the amount of current being drawn from the circuit and thus limiting the rate of change of the high impedance node. Typically an external resistor to GND is sufficient to set the slew rate at a desired level. Leaving the -SRC Pin open will give the highest speed performance. The external current I _{STEAL} for a resistor R _{STEAL} connected from -SRC to GND may be calculated by: $I_{STEAL} = (V_{EE} + 0.35)/R_{STEAL}$.

HFA5253

Absolute Maximum Ratings

Supply Voltage	19V
Differential Input Voltage (DATA and HIZ)	5V
Output Current Continuous (Note 1)	160mA
Input Voltage (Any pin except as specified)	V_{CC} to V_{EE}
V_{OUT} Voltage (Note 3)	9V to -4V
V_{HIGH} Voltage	V_{CC} to -4V

Operating Conditions

V_{LOW} Voltage	9V to V_{EE}
V_{HIGH} to V_{LOW} Voltage	11V to 0V ($V_{HIGH} > V_{LOW}$)
Slew Rate Control Current (+SRC, -SRC)	12mA
Temperature Range	0°C to 50°C

CAUTION: Stresses above those listed in "Absolute Maximum Ratings" may cause permanent damage to the device. This is a stress only rating and operation of the device at these or any other conditions above those indicated in the operational sections of this specification is not implied.

NOTES:

- Internal Power Dissipation may limit Output Current below 160mA.
- θ_{JA} is measured with the component mounted on an evaluation PC board in free air.
- Shorting the output to a voltage outside the specified range may damage the output.

Thermal Information

Thermal Resistance (Typical, Note 2)	θ_{JA} (°C/W)	θ_{JC} (°C/W)
20 Ld PSOP Package	49	2
(θ_{JC} Measured At Copper Slug Top Center with Infinite Heat Sink)		
Maximum Junction Temperature (Die)	175°C	
Maximum Junction Temperature (Plastic Package)	150°C	
Maximum Storage Temperature Range	-65°C to 150°C	
Maximum Lead Temperature (Soldering 10s)	300°C	
(PSOP - Lead Tips Only)		

Electrical Specifications $V_{CC} = +11.2V$; $V_{EE} = -6.4V$; $V_{IH} = -0.9V$; $V_{IL} = -1.75V$; +SRC and -SRC are Not Connected Unless Otherwise Specified

PARAMETER	TEST CONDITIONS	(NOTE 4) TEST LEVEL	TEMP. (°C)	MIN	TYP	MAX	UNITS
INPUT CHARACTERISTICS (V_{HIGH}, V_{LOW})							
V_{HIGH} Input Offset Voltage		A	25	-150	-50	+50	mV
V_{LOW} Input Offset Voltage		A	25	-150	-50	+50	mV
V_{HIGH} Input Bias Current	$V_{HIGH} = -3.25V$ to $+8.5V$	A	25	-50	110	400	μA
V_{LOW} Input Bias Current	$V_{LOW} = -3.5V$ to $+8.25V$	A	25	-400	-110	50	μA
V_{HIGH} Voltage Range		A	25	-3.5	-	8.5	V
V_{LOW} Voltage Range		A	25	-3.5	-	8.5	V
V_{HIGH} to V_{LOW} Differential Voltage Range	$V_{HIGH} \geq V_{LOW}$	A	25	0	-	9.5	V
V_{HIGH}/V_{LOW} Interaction (Notes 5, 17)	At 500mV	A	25	-	2	4	mV
	At 250mV	A	25	-	20	40	mV
LOGIC INPUT CHARACTERISTICS (DATA, \overline{DATA}, HIZ, \overline{HIZ})							
Logic Input Voltage Range		B	25	-3	-	8	V
Logic Differential Input Voltage		B	25	0.4	-	5	V
DATA/ \overline{DATA} Logic Input High Current	$V_{IH} = 0V$, $V_{IL} = -2V$	A	25	-50	110	700	μA
DATA/ \overline{DATA} Logic Input Low Current	$V_{IH} = 0V$, $V_{IL} = -2V$	A	25	-700	-300	50	μA
HIZ/ \overline{HIZ} Logic Input High Current	$V_{IH} = 0V$, $V_{IL} = -2V$	A	25	-50	70	400	μA
HIZ/ \overline{HIZ} Logic Input Low Current	$V_{IH} = 0V$, $V_{IL} = -2V$	A	25	-400	-80	50	μA
TRANSFER CHARACTERISTICS							
V_{HIGH} Voltage Gain	$V_{HIGH} = -1V$ to $6.5V$	A	25	0.95	0.97	1	V/V
V_{LOW} Voltage Gain	$V_{LOW} = -1.5V$ to $6V$	A	25	0.95	0.97	1	V/V
V_{HIGH}/V_{LOW} Linearity Error	Fullscale = 5V, Note 6	A	25	-0.2	-	0.2	%
	Fullscale = 10.5V, Note 7	A	25	-0.4	-	0.4	%
V_{HIGH}/V_{LOW} -3dB Bandwidth	200mV _{p-p}	B	25	-	100	-	MHz
Typical Slew Rate Control Range	$I_{STEAL} = 0mA$ to 10mA, 5V Step	B	25	1.0	-	2.8	V/ns
+SRC Pin Voltage		C	25	-	$V_{CC} - 0.35$	-	V
-SRC Pin Voltage		C	25	-	$V_{EE} + 0.35$	-	V
SWITCHING CHARACTERISTICS ($Z_{LOAD} = 16$ inches of RG-58 Terminated with 50Ω)							
Propagation Delay (Notes 8, 10)		B	25	1	-	2	ns
Propagation Delay Match (Rising to Falling Edge, Notes 8, 10)		B	25	-100	-	100	ps
Rising Edge Propagation Delay vs Duty Cycle (Notes 9, 10)		B	25	-120	-20	80	ps

HFA5253

Electrical Specifications $V_{CC} = +11.2V$; $V_{EE} = -6.4V$; $V_{IH} = -0.9V$; $V_{IL} = -1.75V$; +SRC and -SRC are Not Connected Unless Otherwise Specified **(Continued)**

PARAMETER	TEST CONDITIONS	(NOTE 4) TEST LEVEL	TEMP. (°C)	MIN	TYP	MAX	UNITS
Falling Edge Propagation Delay vs Duty Cycle (Notes 9, 10)		B	25	-80	20	120	ps
Active to HIZ Delay (Note 10)		B	25	1.5	2.0	2.5	ns
HIZ to Active Delay (Note 10)		B	25	2.8	3.3	3.8	ns
TRANSIENT RESPONSE ($Z_{LOAD} = 16$ inches of RG-58 Terminated with 5pF)							
Rise/Fall Time	1V _{P-P} , 20% - 80% (Note 11)	B	25	350	450	500	ps
	3V _{P-P} , 10% - 90% (Note 11)	B	25	700	890	1000	ps
	5V _{P-P} , 10% - 90% (Note 12)	B	25	1.1	1.3	1.7	ns
Rise/Fall Time Match (Note 12)		B	25	-	100	-	ps
Minimum Pulse Width (Note 13)	1V _{P-P}	B	25	-	1.0	-	ns
	3V _{P-P}	B	25	-	1.2	-	ns
	5V _{P-P}	B	25	-	2.0	-	ns
Overshoot/Undershoot/Preshoot	3V _{P-P}	B	25	-	5	-	%
Data Settling Time (Note 14)	To 1%	B	25	-	10	-	ns
OUTPUT CHARACTERISTICS							
Output Voltage Swing	No Load at $V_{CC} = 11V$, $V_{EE} = -6.2V$	A	25	-3	-	8	V
Output Amplitude Voltage	$V_{OH} - V_{OL}$	A	25	0.25	-	9.0	V
DC Output Resistance (Note 15)	-3V to 8V	A	25	45	47	49	Ω
Output Leakage - HIZ	-3V to 8V	A	25	-100	-	100	nA
Output Capacitance - HIZ		C	25	-	5	-	pF
Output Current - Active		A	25	80	100	-	mA
Output Short Circuit Range (Note 3)		A	25	-4.0	-	9.0	V
POWER SUPPLY CHARACTERISTICS ($V_{HIGH} = 5V$ Active, No Load)							
V_{HIGH} Power Supply Rejection Ratio (Note 16)		A	25	-	14	40	mV/V
V_{LOW} Power Supply Rejection Ratio (Note 16)		A	25	-	14	40	mV/V
Total Supply Current		A	25	90	96	98	mA
I_{CC1}/I_{EE1} Supply Current		B	25	-	74	-	mA
I_{CC2}/I_{EE2} Supply Current		B	25	-	22	-	mA
Supply Voltage Range	V_{CC}	A	25	11.0	11.2	11.4	V
	V_{EE}	A	25	-6.6	-6.4	-6.2	V
	$V_{CC} - V_{EE}$	A	25	17.2	-	18.0	V
Power Dissipation	$V_{CC} = 11.2V$, $V_{EE} = -6.4V$, No Load	A	25	-	-	1.72	W

NOTES:

4. Test Level: A = 100% production tested, B = Typical or limit based on lab characterization of a limited number of lots, C = Design Information, goal or condition.
5. V_{HIGH} to V_{LOW} Interaction is measured as the change in V_{OUT} (the active channel) due to a change in the inactive channel. V_{HIGH} Interaction at 250mV is measured as the deviation from 1V as V_{LOW} is changed from 0V to 750mV (Referred to V_{OUT}). V_{LOW} Interaction at 250mV is measured as the deviation from 0V as V_{HIGH} is changed from 1V to 250mV (Referred to V_{OUT}).
6. For $V_{HIGH} = 0V$ to 5V, for $V_{LOW} = 0V$ to 5V, Fullscale = 5V, 0.1% = 5mV. Output Amplitude ($V_{HIGH} - V_{LOW}$) = 1V_{P-P}.
7. For $V_{HIGH} = -2.5V$ to 8V, for $V_{LOW} = -3.0V$ to 7.5V, Fullscale = 10.5V, 0.1% = 10.5mV. Output Amplitude ($V_{HIGH} - V_{LOW}$) = 1V_{P-P}.
8. 3V Step, 50% duty cycle, 200ns period.
9. 0V to 3V Step, 200ns period, Pulse Width is varied from 5ns to 195ns.
10. Test is performed into a 50 Ω load with a 3V step. Measurement is made from the 50% of the input to 50% of output.
11. Limit based on calculation.
12. 5V Step, 50% duty cycle, 100ns period.
13. Minimum Pulse Width is measured 50% to 50% of specified amplitude with pulse peak at 100% of amplitude.
14. 3V Step, measured from 50% of input to $\pm 1\%$ of reference value at 50ns.
15. Dynamic Output Resistance will be higher (typ 48.5 Ω) than DC Output Resistance. DC Output Resistance is measured at 0V with I_{OUT} set from 0mA to 40mA.
16. $V_{HIGH} = 2.6V$, $V_{LOW} = 2.3V$, $V_{CC} = 10.2V$ to 11.2V, $V_{EE} = -5.4V$ to -6.4V.
17. Input voltages V_{HIGH} and V_{LOW} are corrected for Offset Voltage and Gain Error.

Functional Block Diagram

The HFA5253 functional block diagram is shown in on the first page of this data sheet.

The control inputs, DATA and $\overline{\text{DATA}}$, determine the output level. If DATA is at logic "1" and $\overline{\text{DATA}}$ is at logic "0", the output level will be the same as V_{HIGH} . If DATA is at logic "0" and $\overline{\text{DATA}}$ is at logic "1", the output will be the same as V_{LOW} . The control inputs, HIZ and $\overline{\text{HIZ}}$, cause the output to become either active or high-impedance. If HIZ is at logic "1" and $\overline{\text{HIZ}}$ is at logic "0", the output will be in high impedance mode. If HIZ is at logic "0" and $\overline{\text{HIZ}}$ is at logic "1", the output will be enabled. The output impedance in the enabled mode is trimmed to 50Ω .

Circuit Schematic

The Pin Driver circuit consists of a switch, an output buffer, and two differential control elements as shown in the circuit Schematic Diagram.

A two stage approach, separating the switch from the output buffer, allows the speed and accuracy requirements of the switch to be de-coupled from the load driving capability of the buffer.

The patented switch circuitry [3] uses cascaded emitter followers as input buffers and also to switch the input V_{HIGH} and V_{LOW} to node VSO. Dual differential pairs controlled by the data timing (DATA and $\overline{\text{DATA}}$) direct current to select

either the V_{HIGH} or V_{LOW} switch. Matching transistor types and transdiodes improve linearity and lowers the voltage offset and offset drift. Stacking two emitter-base junctions allows the V_{HIGH} to V_{LOW} range to be extended to two Emitter - Base breakdown voltages of the process. The speed of the pin driver is largely determined by the current flowing through the switch stage and the collector-base capacitance of the output stage transistors connected to the node VSO. The Slew Rate Control Pins, +SRC and -SRC, allow the user to control the amount of current available in the V_{HIGH} and V_{LOW} switch, respectively and thus the slew rate of node VSO.

The output stage consists of cascaded emitter followers constructed in a typical push-pull manner as shown in the Schematic Diagram. However, transdiodes are added to increase the voltage breakdown characteristics of the output during high impedance mode. HIZ and $\overline{\text{HIZ}}$ control the mode of the output stage. A trimmed, NiCr resistor is added to provide the 50Ω output impedance.

Overall, a symmetry of device types and paths is constructed to improve slew and delay symmetry. Both the V_{HIGH} to V_{OUT} path and the V_{LOW} to V_{OUT} path contain three NPN and three PNP transistors operating at similar collector currents. Thus the transient response of V_{HIGH} to V_{LOW} and V_{LOW} to V_{HIGH} are kept symmetrical. Also, a trimmable current reference (not shown) allows the AC parameters to be adjusted to maintain unit to unit consistency.

Schematic Diagram

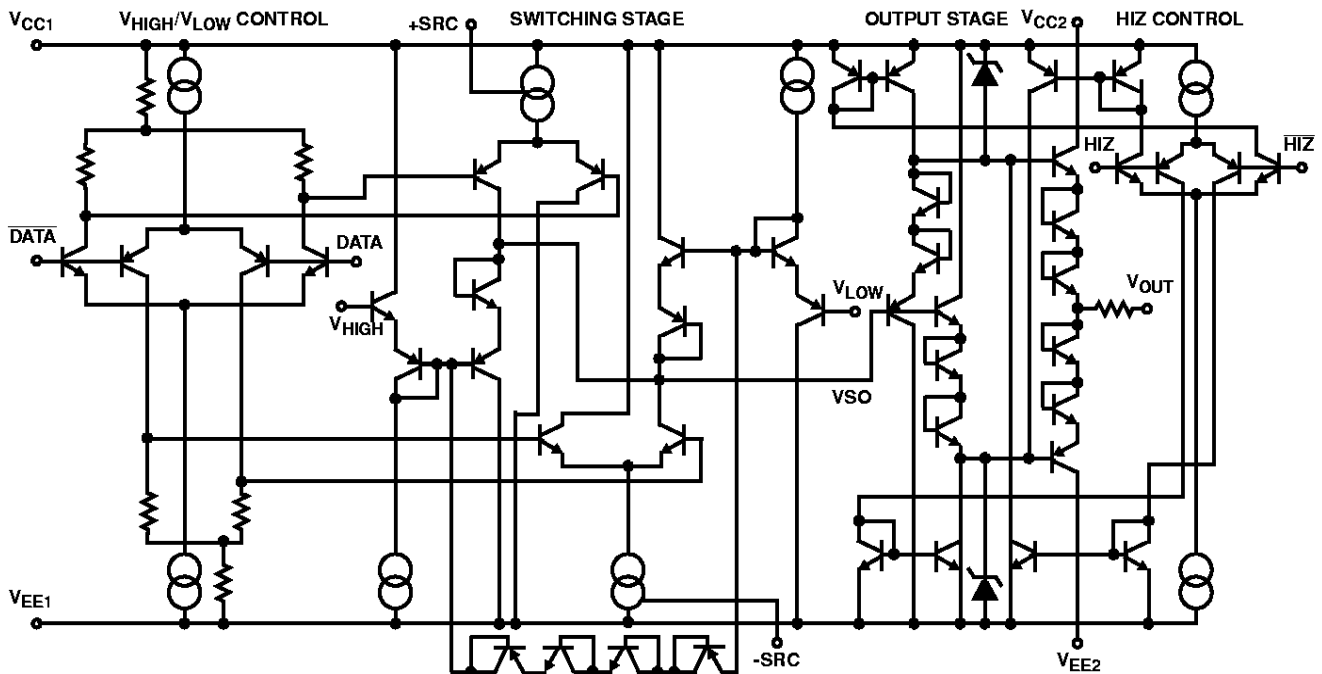

Application Information

The HFA5253 is a pin driver designed for use in automatic test equipment (ATE) and high speed pulse generators. Pin drivers, especially those with very high-speed performance, have generally been implemented with discrete transistors (sometimes GaAs) on a circuit board or in a hybrid. Recent IC process improvements, specifically Harris' UHF1 process [2], have enabled the manufacturing of the 500MHz and 800MHz silicon monolithic pin drivers, HFA5250, HFA5251 and now the HFA5253.

The ultra high speed performance of the HFA5253 is a result of UHF1 process leverages: low parasitic collector-to-substrate capacitance of the bonded wafer, low collector-to-base parasitic capacitance of the self-aligned base/emitter technology and ultra high f_T NPN (8GHz) and PNP (5.5GHz) poly-silicon transistors.

Definition of Terms

V_{OH} and V_{OL}

Output High Voltage and Output Low Voltage. V_{OH} is the voltage at V_{OUT} when the HIZ input is low and the DATA input is high. V_{OL} is the voltage at V_{OUT} when HIZ is low and DATA is low. The V_{OH} and V_{OL} levels are set with the V_{HIGH} and V_{LOW} inputs respectively.

Offset Voltage

Offset Voltage is the DC error between the voltage placed on V_{HIGH} or V_{LOW} and the resulting V_{OH} and V_{OL} . V_{HIGH} Offset Voltage Error is obtained by measuring V_{OH} with V_{HIGH} set to 0V and V_{LOW} set to -2.5V to minimize interaction effects. V_{LOW} Offset Voltage Error is the measurement of V_{OL} with V_{LOW} set to 0V and V_{HIGH} set to +7.5V.

Gain

Gain is defined as the ratio of output voltage change to input voltage change for a defined range. V_{HIGH} Gain is calculated with the following equation with V_{LOW} fixed at -2.5V:

$$V_{HIGH} \text{ GAIN} = \frac{V_{OH}(V_{HIGH} \text{ at } 6.5V) - V_{OH}(V_{HIGH} \text{ at } -1V)}{7.5}$$

V_{LOW} Gain is calculated in a similar manner.

$$V_{LOW} \text{ GAIN} = \frac{V_{OL}(V_{LOW} \text{ at } 6V) - V_{OL}(V_{LOW} \text{ at } -1.5V)}{7.5}$$

V_{HIGH} is held fixed at 7.5V. These Gain calculations minimize the effects of Interaction and End Point Nonlinearities.

Linearity Error

Linearity Error is a measure of output voltage worst case deviation from a straight line that has been corrected for offset and 7.5V Gain. Linearity Error is given as a percentage of fullscale and is done in two ranges, 5V and 10.5V. DATA is measure at 0.5V steps from -2.5V to 8V for V_{HIGH} and -3V to 7.5V for V_{LOW} . The Linearity Error equation is as follows for 10.5V fullscale:

$$V_{OUT}(IDEAL) = V_{IN} \times \text{Gain} + \text{Offset}$$

$$\text{Linearity Error} = \frac{V_{OUT} - V_{OUT}(IDEAL)}{10.5}$$

The Linearity Error equation is as follows for 5V fullscale:

$$\text{Linearity Error} = \frac{V_{OUT} - V_{OUT}(IDEAL)}{5}$$

Linearity Error is calculated for every data point in the range and the worst case value is recorded.

V_{HIGH} to V_{LOW} Interaction

V_{HIGH} to V_{LOW} Interaction is the change in V_{OUT} (the active channel) due to the inactive channel. V_{HIGH} Interaction is measured as the change in V_{OH} from 1V as V_{LOW} is moved from 0V to 750mV (V_{LOW} is corrected for gain and offset errors). V_{LOW} Interaction is measured as the change in V_{OL} from 0V as V_{HIGH} is moved from 1V to 250mV (with V_{HIGH} corrected for gain and offset errors). The minimum recommended difference between V_{HIGH} and V_{LOW} for the HFA5253 is 250mV.

Speed Advantage

Harris Pin Drivers on bonded-wafer technology definitely have a speed advantage, coming from the low collector-to-substrate capacitance and the high f_T of the transistors. In addition, the patented switching stage which fits uniquely to Harris' UHF1 process is another big contributor for the high speed. This switching circuitry requires low series-resistance NPN and PNP transistors available in UHF1. The rise and fall times of the pin driver are largely determined by the slew rate at the node VSO in the Schematic. The dominant mechanism for the slew rate is the charging/discharging of the collector-base capacitors of the transistors connected to the node VSO. The charging/discharging currents are coming from the switching stage current sources. The fast rise and fall times are achieved because of the negligible collector-to-substrate capacitance and the small base-collector capacitance due to the self-aligned recessed oxide [2].

The DATA/DATA differential stage is not a factor for the speed if its current sources have enough current not to bottleneck the transient. However it should be noted that the propagation delay mismatch is determined by this stage. Sufficient current is allocated to the differential stage current sources to best match the low-to-high and high-to-low transient propagation delays.

The specified load condition is a 16 inch 50Ω SMA cable with a 5pF capacitor at the end of the cable. This load simulates a typical ATE environment for a DUT (Device Under Test) with high impedance (>1kΩ) digital inputs. The rise/fall time for HFA5253 with 5V_{P-P} is typically 1.3ns. Pin drivers, built out of the same circuit structure as shown in the Schematic, can be made faster by trimming for a higher power supply current. Currently the pin driver has rise/fall times of less than 1ns (10% to 90% of 5V_{P-P}) when I_{CC} is trimmed to 125mA. Further speed enhancement will be made if there is a market demand.

Basic ATE System Application

Figure 1 shows a pin driver in a typical per-pin ATE system. The pin driver works closely with the Dual-Level Comparator and the Active Load. When the DUT pin acts as an input waiting for

a series of digital signals, the pin driver becomes active with a logic "0" applied on the HIZ pin and provides the DUT pin with digital signals. When the DUT pin acts as an output, the pin driver output will be in high impedance mode (HIZ) with a logic "1" applied to the "HIZ" pin. During this high impedance mode the pin driver presents a capacitance of less than 5pF to the DUT. Special care has to be taken to match the impedance (to 50Ω) at the pin driver output to minimize reflections.

The Dual-Level Comparator detects the logic levels of the DUT pin when it acts as an output. The comparator has two threshold level inputs, V_{CH} and V_{CL} . The logic level information of the DUT pin output is sent to the edge/window comparator through the Dual-Level Comparator. The edge/window comparator interprets this information in terms of corresponding transient performance in conjunction with the timing information. Thus it detects any possible failure transients.

The formatter sends a sequence of digital information to the pin driver which contains logic information over time. The Active Load is enabled when the DUT pin acts as an output. It simulates the load of the DUT pin by sinking or sourcing programmed current. Finally the sequencer controls the overall activities of the automatic testing.

Decoupling Circuit for Oscillation-Free Operation

To ensure oscillation-free operation in ATE or pulse generator applications, the pin driver needs an appropriate decoupling circuit on a printed circuit board which consists of chip capacitors and chip resistors. Figures 2, 3, and 4 refer to a proven decoupling circuit currently working in the lab and a 1X scale film of its associated PC board (metal level). Do not connect the V_{CC1} and V_{CC2} pins or the V_{EE1} and V_{EE2} pins together immediately, rather run separate traces until they can be joined at a large by-pass capacitor ($0.1\mu F \parallel 10.0\mu F$).

The control pins, DATA, \overline{DATA} , HIZ, and \overline{HIZ} are fed ECL signals through 50Ω micro-strip lines terminated with 50Ω for impedance matching since the input impedance at these pins is much higher than 50Ω. At the end of the micro-strip lines there is usually a high-speed pulse generator with an output impedance of 50Ω. A 50Ω micro-strip line is con-

nected to each of the pins, \overline{DATA} and \overline{HIZ} through a 50Ω chip resistor to monitor the pulse signals.

PARTS LIST

QTY	VALUE	COMPONENT
6	470pF	Chip Cap: 0805
4	0.1μF	Chip Cap: 0805
2	10μF	Tant.
8	50Ω	Chip Res: 0805
2	100Ω	Chip Res: 0805
7	SMA Jacks	Wide Body
1	20 Lead PSOP	HFA5253
4	4-40	1" Standoff
4	4-40	1/4" Screws
2	Twisted Wire Assemblies with 4 Wires Each: One for V_{CC} , V_{HIGH} , +SRC, GND; and 1 for V_{EE} , V_{LOW} , -SRC, GND.	

The input pins, V_{HIGH} , V_{LOW} , +SRC, and -SRC need to be protected from any capacitively coupled AC noise. Normally this protection can be achieved by having a low pass filter consisting of a 50Ω chip resistor and a chip capacitor, 470pF for V_{HIGH}/V_{LOW} and 0.1μF for +SRC/-SRC. Without this protection circuit the pin driver may oscillate due to signals fed back from the output through the PC board ground.

The power supply pins, V_{CC1} , V_{CC2} , V_{EE1} , and V_{EE2} , require decoupling chip capacitors of 470pF, 0.1μF, 10μF. Having decoupling capacitors close to V_{CC2} and V_{EE2} is essential since large AC current will flow through either V_{CC2} or V_{EE2} during transients.

The output of the pin driver is usually connected to the device-under-test (DUT) through 50Ω micro-strip line and coaxial cable which carries the signal to a high input impedance DUT pin.

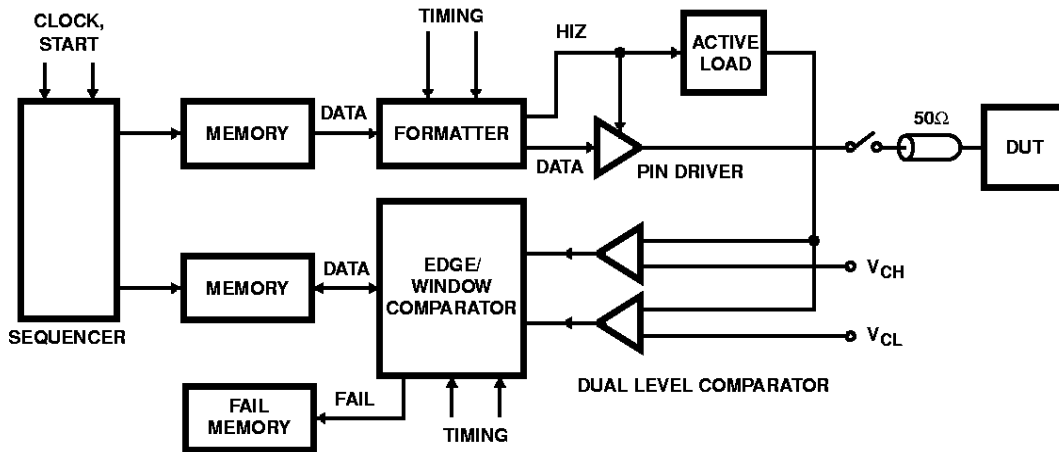

FIGURE 1. TYPICAL ATE SYSTEM

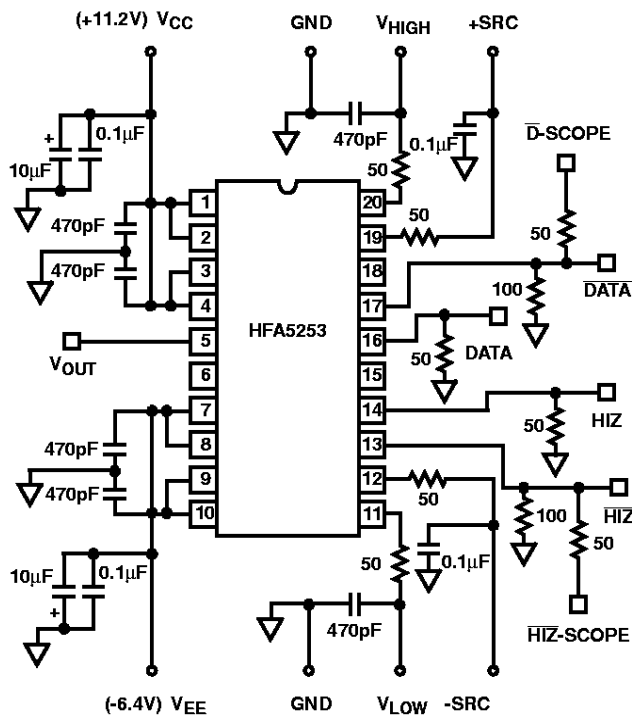

FIGURE 2. DECOUPLING CIRCUIT SCHEMATIC

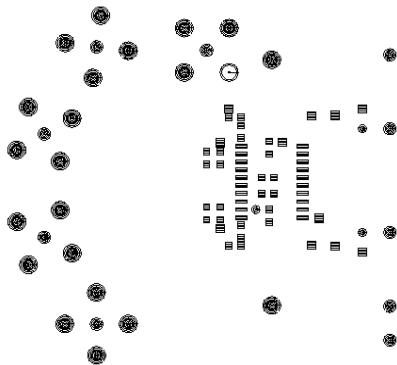

FIGURE 3. 1X PC BOARD LAYOUT (BOTTOM VIEW)



FIGURE 4. 1X PC BOARD LAYOUT (TOP VIEW)

References

- [1] Taewon Jung and Donald K. Whitney Jr., "A 500MHz ATE Pin Driver," Bipolar Circuits and Technology Meeting Proceedings, pp238-241, October 1992.
- [2] Chris K. Davis et. al., "UHF1: A High Speed Complementary Bipolar Analog Process on SOI," Bipolar Circuits and Technology Meeting Proceedings, pp260-263, October 1992.
- [3] Donald K. Whitney Jr., "Symmetrical, High Speed, Voltage Switching Circuit," United States Patent Pending, Filed November 1991.