

Product Preview
IR Remote Control Transmitter
CMOS

The MC44107 remote control transmitter converts a keyboard input into a pulse code modulated signal suitable for infrared transmission to an appropriate receiver. Its large command capacity, 512 commands, makes it highly suited to remote control applications in TV, video, hi-fi, etc. The transmitter is an LSI circuit realized in complementary MOS technology.

- Binary Coded, 9-Bit PCM Data Word
- Simple Modulator Requirements
- One-Pin Reference Oscillator for External Ceramic Resonator
- Very Low (Maximum 1 μ A) Standby Current Consumption
- Wide Operating Voltage Range: 4 to 10 V
- Operating Temperature Range: - 40 to 85° C

MC44107

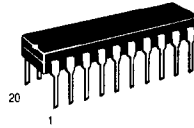

P SUFFIX
PLASTIC DIP
CASE 738

ORDERING INFORMATION

MC44107P Plastic DIP

PIN ASSIGNMENT

R5	1	20	MUX
R2	2	19	CD
R7	3	18	CF
D _{out}	4	17	OSC
R1	5	16	CG
R6	6	15	CC
R8	7	14	CB
R4	8	13	CE
R3	9	12	CH
V _{SS}	10	11	PAGE

BLOCK DIAGRAM

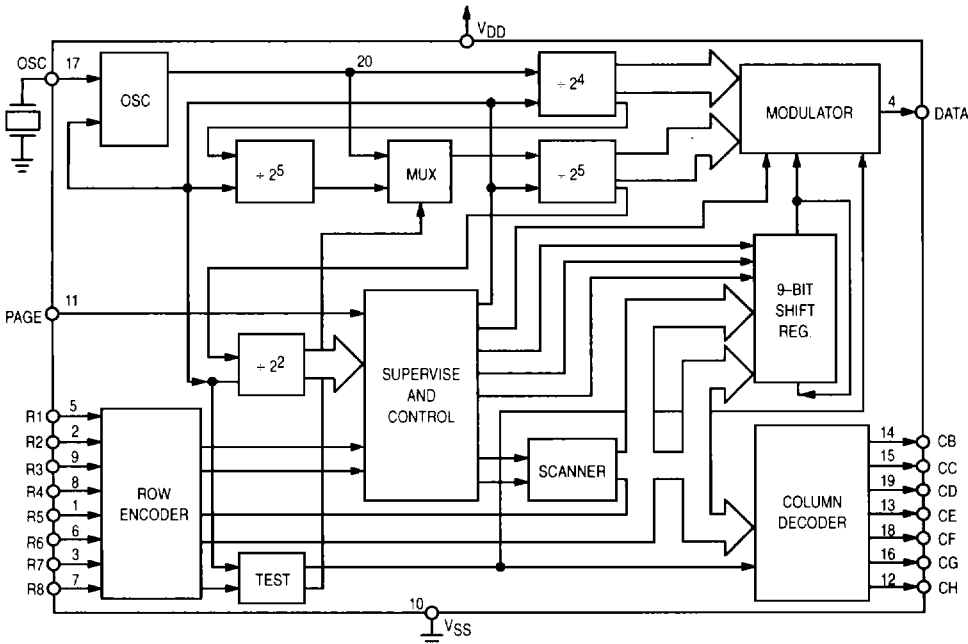

This document contains information on a product under development. Motorola reserves the right to change or discontinue this product without notice.

REV 2
8/95

MAXIMUM RATINGS* (Voltages referenced to V_{SS})

Parameter	Symbol	Value	Unit
DC Supply Voltage	V_{DD}	- 0.5 to + 12	V
Input Voltage, All Inputs	V_{in}	- 0.5 to $V_{DD} + 0.5$	V
DC Current Drain per Pin (Except Signal Out and V_{DD})	I	2	mA
DC Current Drain (Signal Out and V_{DD})	I	10	mA
Storage Temperature Range	T_{stg}	- 65 to + 150	°C

* Maximum Ratings are those values beyond which damage to the device may occur. Functional operation should be restricted to the limits in the Electrical Characteristics tables or Pin Descriptions section.

This device contains protection circuitry to guard against damage due to high static voltages or electric fields; however, it is advised that precautions be taken to avoid application of voltage higher than maximum rated voltages to this high-impedance circuit. For proper operation it is recommended that V_{in} and V_{out} be constrained to the range $V_{SS} \leq (V_{in} \text{ or } V_{out}) \leq V_{DD}$.

Unused inputs must always be tied to an appropriate logic voltage level (e. g., either V_{SS} or V_{DD}).

ELECTRICAL CHARACTERISTICS

Characteristic	Symbol	V_{DD} V_{dc}	- 40°C		25°C			85°C		Unit
			Min	Max	Min	Typ	Max	Min	Max	
Inputs R1, R8 and PAGE (with Pull-Up) I_{in} at $V_{in} = 1.2$ V I_{in} at $V_{in} = 3$ V I_{in} at $V_{in} = 2.8$ V I_{in} at $V_{in} = 7$ V	I_{in}	4	—	70	—	—	50	—	40	μ A
		10	—	350	—	—	250	—	200	
		4	5	—	4	—	—	3	—	
		10	25	—	20	—	—	15	—	
V_{IH} V_{IH}	V_{IH}	4	2.8	—	2.8	—	—	2.8	—	V
		10	7	—	7	—	—	7	—	
V_{IL} V_{IL}	V_{IL}	4	—	1.2	—	—	1.2	—	1.2	V
		10	—	3	—	—	3	—	3	
Outputs CB, CH (Open Drain) I_{on} at $V_{on} = 1.2$ V I_{on} at $V_{on} = 3$ V	I_{on}	4	270	—	200	—	—	160	—	μ A
		10	1350	—	1000	—	—	800	—	
I_{off} I_{off}	I_{off}	4	—	1	—	1	—	—	1	μ A
		10	—	1	—	1	—	—	1	
Output DATA V_{OH} at $I_{source} = 1.0$ mA	V_{OH}	4	3.2	—	3.0	—	1	2.8	—	V
		10	9.6	—	9.5	—	0.5	9.4	—	
V_{OL} at $I_{sink} = 1.0$ mA	V_{OL}	4	—	0.8	—	—	1	—	1.2	V
		10	—	0.4	—	—	0.5	—	0.6	
Supply Voltage	V_{DD}	—	4	10	4	—	10	4	10	V
Standby Current	I_{DDSTB}	4	—	—	—	0.02	1	—	—	μ A
		10	—	—	—	0.02	1	—	—	
Active Mode Current	I_{DDACT}	4	—	—	—	0.07	1	—	—	mA
		10	—	—	—	0.45	2	—	—	
Oscillator Frequency	f_{osc}	—	—	—	430	—	530	—	—	kHz

CIRCUIT OPERATION

The transmitter emits a 9-bit, labelled A (LSB) to I (MSB), binary code able to encode 512 commands organized as 8 pages of 64 commands. All of these commands are user selectable except the last command (511) which is used as an SST, Start/Stop Transmission code.

Each bit of the transmitted signal is in the form of a biphasic pulse code modulated (PCM) signal, whose coding is shown in Figure 1.

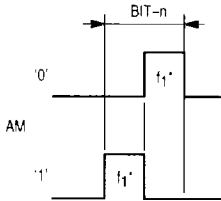

* f_1 is a train of pulses at the carrier frequency - 16.

Figure 1. Signal Coding

The keyboard can be a simple switch matrix, connected between the eight row inputs (1 to 8) and the seven column outputs (B to H). V_{SS} acts as the eighth column line to give the full complement of 64 commands per page. The maximum "ON" resistance of the keyboard must be limited to 500 Ω .

Page access is accomplished by connecting, by means of a key, the page input to one of the seven column outputs or by leaving the input circuit open.

One of the circuit's major features is its low standby current consumption — typically less than 1 μ A. For this reason the battery may be left continuously in circuit.

As soon as a key is selected, the circuit switches to its active mode and enables the oscillator. To allow for accidental activation and/or key bounce, the circuit requires that the key is held for a minimum delay of t_{key} , which in the case of a 500 kHz oscillator is 65.6 ms. After this delay the column/row/page command, consisting of a string of messages (see

Figure 2), appropriate to the key selected will be transmitted and repeated until the key is released.

Any page key required must be selected before, and held during, the selection of the column/row matrix key. If this sequence is not followed, the circuit will default to the appropriate command between 0 and 63. If two or more page keys are accidentally held down, only the first one pressed will be detected.

A command consists of several messages. Each command starts with the message 511 (SST) followed by the message appropriate to the key selected. These messages are repeated until the key is released. The final message is always followed by the SST message, 511.

Every message consists of a pre-bit, a pre-bit pause, a start-bit, and nine data bits, where the pre-bit and the start-bit are always logical "1". The pre-bit allows for the set up of the AGC loop in the receiving preamplifier. The truth tables for data bits are given in Tables 1 and 2, while Figure 2 shows the timing relationships between the commands, messages, and modulation.

In the event of accidental multi-key operation, the circuit will react in one of three ways, depending on the combination of the keys selected.

When two or more keys are connected to the same row input and any column output except A, the command appropriate to the first key selected will be transmitted until that key is released. After the SST code has been transmitted, assuming another key is still selected, the command appropriate to that key will be transmitted. If the other key has been released in the meantime, the circuit will revert to standby.

If two keys are selected in the same row with one being connected to column A, any transmission will terminate with the SST code and then the circuit will transmit the command appropriate to the key connected to column A.

In the case where two or more keys connected to the same column are selected, the circuit reacts in a normal manner to the first key activated. Upon selection of the second key, the SST code is transmitted and the circuit will revert to the standby mode. Only when the multi-key condition is released and a single key is selected will the circuit resume operation, as previously described.

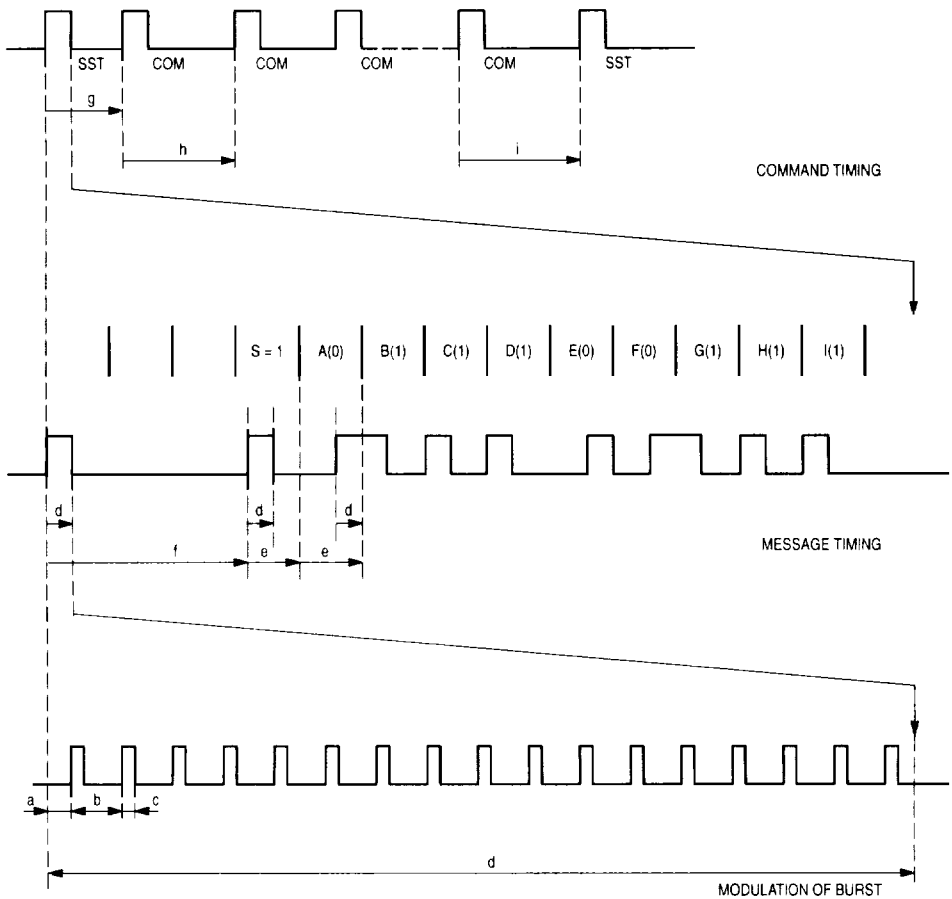

CIRCUIT TIMING*

Modulation	$a = 4/f_{osc}$ $b = 16/f_{osc}$ $c = 4/f_{osc}$ $d = 256/f_{osc}$	8 μ s 32 μ s 8 μ s 512 μ s	$1/f$ Carrier Half-Bit Time
Message Timing	$d = 256/f_{osc}$ $e = 512/f_{osc}$ $f = 1536/f_{osc}$	512 μ s 1.02 ms 3.072 ms	Half-Bit Time Bit Time Pre-Pulse Time
Command Timing	$g = 32 \times \text{Bit Time}$ $h = 128 \times \text{Bit Time}$ $i = 128 \times \text{Bit Time}$ $t_{key} = 64 \times \text{Bit Time}$	32.8 ms 131 ms 131 ms 65.6 ms	

* Times indicated are typical and refer to an oscillator frequency of 500 kHz.

Figure 2. MC44107 Remote Control Transmitter Timing Diagram

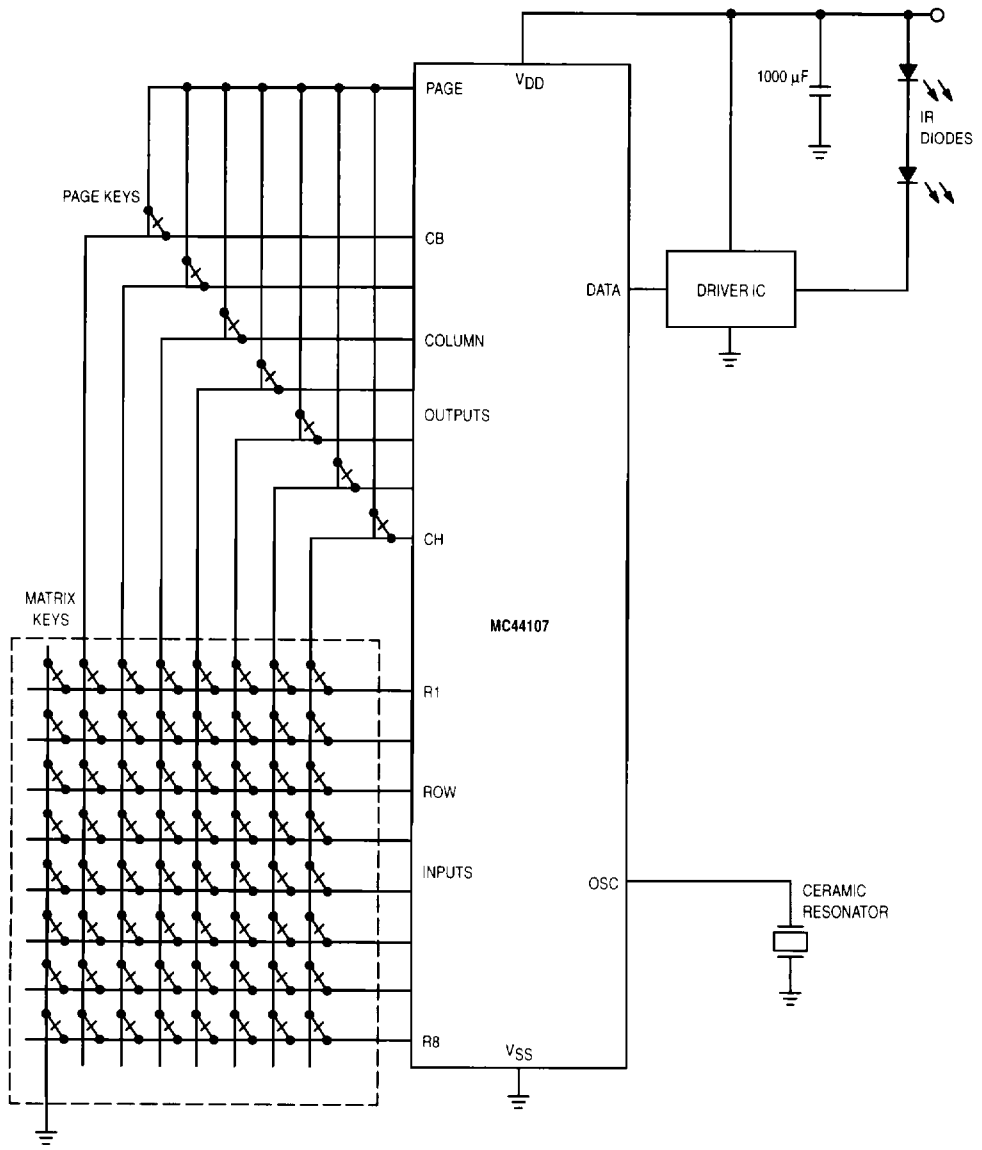

Figure 3. Transmitter Circuit

PIN DESCRIPTIONS

ROW INPUTS

1 to 8 (Pins 1, 2, 3, and 5 – 9) In the standby mode these inputs are held high by internal pull-up resistors. As soon as a key is pressed, a logical "0" is presented by the column output on that particular line. This switches the circuit to the active mode and starts the oscillator.

COLUMN OUTPUTS

B to H (Pins 12 – 16, 18, and 19) In the standby mode these pins are held low, logical "0". When a key is selected and the oscillator starts, the outputs are released and the scanning routine starts.

PAGE INPUT

(Pin 11) This input is connected directly to the transmitter's supervisory and control circuitry and may be connected to one of the column outputs, via a key, or left open. If the pin is left open, the first page of 64 commands will be available

(see Table 1). If connected to one of the column outputs, the remaining pages become available (see Table 2). The specified standby current consumption is maintained regardless of the load applied to the input: $0 V < V_{page} < V_{DD}$.

OSCILLATOR

(Pin 17) A one-pin oscillator is incorporated into the circuit, which has been specifically designed for use with an inexpensive ceramic resonator between 430 kHz and 530 kHz. It is possible to use a tuned LC circuit with a series capacitor, in place of the ceramic resonator.

DATA OUTPUT

(Pin 4) This output provides the modulated signal for subsequent external amplification.

SPECIAL NOTE: KEYBOARD

It is important, when considering a keyboard, that the maximum "ON" resistance, even after aging, of 500 Ω is strictly observed.

Table 1. Transmitted Codes

Message Number	Matrix Connect Row/Col	Binary Code									Message Number	Matrix Connect Row/Col	Binary Code								
		A	B	C	D	E	F	G	H	I			A	B	C	D	E	F	G	H	I
0	1A	0	0	0	0	0	0	0	0	0	32	5A	0	0	0	0	0	1	0	0	0
1	1B	1	0	0	0	0	0	0	0	0	33	5B	1	0	0	0	0	1	0	0	0
2	1C	0	1	0	0	0	0	0	0	0	34	5C	0	1	0	0	0	1	0	0	0
3	1D	1	1	0	0	0	0	0	0	0	35	5D	1	1	0	0	0	1	0	0	0
4	1E	0	0	1	0	0	0	0	0	0	36	5E	0	0	1	0	0	1	0	0	0
5	1F	1	0	1	0	0	0	0	0	0	37	5F	1	0	1	0	0	1	0	0	0
6	1G	0	1	1	0	0	0	0	0	0	38	5G	0	1	1	0	0	1	0	0	0
7	1H	1	1	1	0	0	0	0	0	0	39	5H	1	1	1	0	0	1	0	0	0
8	2A	0	0	0	1	0	0	0	0	0	40	6A	0	0	0	1	0	1	0	0	0
9	2B	1	0	0	1	0	0	0	0	0	41	6B	1	0	0	1	0	1	0	0	0
10	2C	0	1	0	1	0	0	0	0	0	42	6C	0	1	0	1	0	1	0	0	0
11	2D	1	1	0	1	0	0	0	0	0	43	6D	1	1	0	1	0	1	0	0	0
12	2E	0	0	1	1	0	0	0	0	0	44	6E	0	0	1	1	0	1	0	0	0
13	2F	1	0	1	1	0	0	0	0	0	45	6F	1	0	1	1	0	1	0	0	0
14	2G	0	1	1	1	0	0	0	0	0	46	6G	0	1	1	1	0	1	0	0	0
15	2H	1	1	1	1	0	0	0	0	0	47	6H	1	1	1	1	0	1	0	0	0
16	3A	0	0	0	0	1	0	0	0	0	48	7A	0	0	0	0	1	1	0	0	0
17	3B	1	0	0	0	1	0	0	0	0	49	7B	1	0	0	0	1	1	0	0	0
18	3C	0	1	0	0	1	0	0	0	0	50	7C	0	1	0	0	1	1	0	0	0
19	3D	1	1	0	0	1	0	0	0	0	51	7D	1	1	0	0	1	1	0	0	0
20	3E	0	0	1	0	1	0	0	0	0	52	7E	0	0	1	0	1	1	0	0	0
21	3F	1	0	1	0	1	0	0	0	0	53	7F	1	0	1	0	1	1	0	0	0
22	3G	0	1	1	0	1	0	0	0	0	54	7G	0	1	1	0	1	1	0	0	0
23	3H	1	1	1	0	1	0	0	0	0	55	7H	1	1	1	0	1	1	0	0	0
24	4A	0	0	0	1	1	0	0	0	0	56	8A	0	0	0	1	1	1	0	0	0
25	4B	1	0	0	1	1	0	0	0	0	57	8B	1	0	0	1	1	1	0	0	0
26	4C	0	1	0	1	1	0	0	0	0	58	8C	0	1	0	1	1	1	0	0	0
27	4D	1	1	0	1	1	0	0	0	0	59	8D	1	1	0	1	1	1	0	0	0
28	4E	0	0	1	1	1	0	0	0	0	60	8E	0	0	1	1	1	1	0	0	0
29	4F	1	0	1	1	1	0	0	0	0	61	8F	1	0	1	1	1	1	0	0	0
30	4G	0	1	1	1	1	0	0	0	0	62	8G	0	1	1	1	1	1	0	0	0
31	4H	1	1	1	1	1	0	0	0	0	63	8H	1	1	1	1	1	1	0	0	0

2

Table 2. Page Table

Message	Page Input Connected To	G	H	I
0 to 63	Not Connected	0	0	0
64 to 127	CB	1	0	0
128 to 191	CC	0	1	0
192 to 255	CD	1	1	0
256 to 319	CE	0	0	1
320 to 383	CF	1	0	1
384 to 447	CG	0	1	1
448 to 511	CH	1	1	1