

## HSDL-3002

IrDA® Data Compliant Low Power 115.2 kbit/s with Remote Control Transmission Infrared Transceiver



## Data Sheet



### Description

The HSDL-3002 is a small form factor single enhanced infrared (IR) transceiver module that provides the combination of (1) interface between logic and IR signals for through-air, serial, half-duplex IR data link, and (2) IR remote control transmission operating at 940 nm for universal remote control applications.

For infrared data communication, the HSDL-3002 provides the flexibility of Low Power SIR applications and remote control applications depending on the application circuit designs as outlined in the Application Circuit section. The transceiver is compliant to IrDA Physical Layer Specifications version 1.4 from 9.6 kbit/s to 115.2 kbit/s and it is IEC 825-Class 1 Eye Safe.

The HSDL-3002 can be shutdown completely to achieve very low power consumption. In the shutdown mode, the PIN diode will be inactive and thus producing very little photocurrent even under very bright ambient light. Such features are ideal for battery operated handheld products.

### Features

- Guaranteed temperature performance,  $-20$  to  $70^{\circ}\text{C}$ 
  - Critical parameters are guaranteed over temperature and supply voltage
- Low power consumption
- Small module size
  - Height: 2.70 mm
  - Width: 9.10 mm
  - Depth: 3.65 mm
- Withstands  $>100$  mV<sub>p-p</sub> power supply ripple typically
- V<sub>CC</sub> supply 2.7 to 5.5 volts
- Integrated EMI shield
- Designed to accommodate light loss with cosmetic windows
- IEC 825-class 1 eye safe

### IrDA Data Features

- Fully compliant to IrDA physical layer specifications version 1.4 from 9.6 kbit/s to 115.2 kbit/s
  - Excellent nose-to-nose operation
  - Link distance up to 50 cm
- Complete shutdown for TXD(IrDA), RXD(IrDA), and PIN diode
- Low shutdown current (10 nA typical)
- LED stuck-high protection

### Remote Control Features

- High radiant intensity
- Spectrally suited to remote control receiver
- Typical link distance at 6 m

### Applications

- Mobile data communication and universal remote control
  - PDAs
  - Mobile phone

## Application Support Information

The Application Engineering Group is available to assist you with the application designs associated with the HSDL-3002 infrared transceiver module. You can contact them through your local sales representatives for additional details.

## Ordering Information

Part Number	Packaging Type	Package	Quantity
HSDL-3002-007	Tape and Reel	Front View	2500

## Marketing Information

The unit is marked with a number “1” and “YWWLL” on the shield for front option.

Y = year

WW = work week

LL = lot information

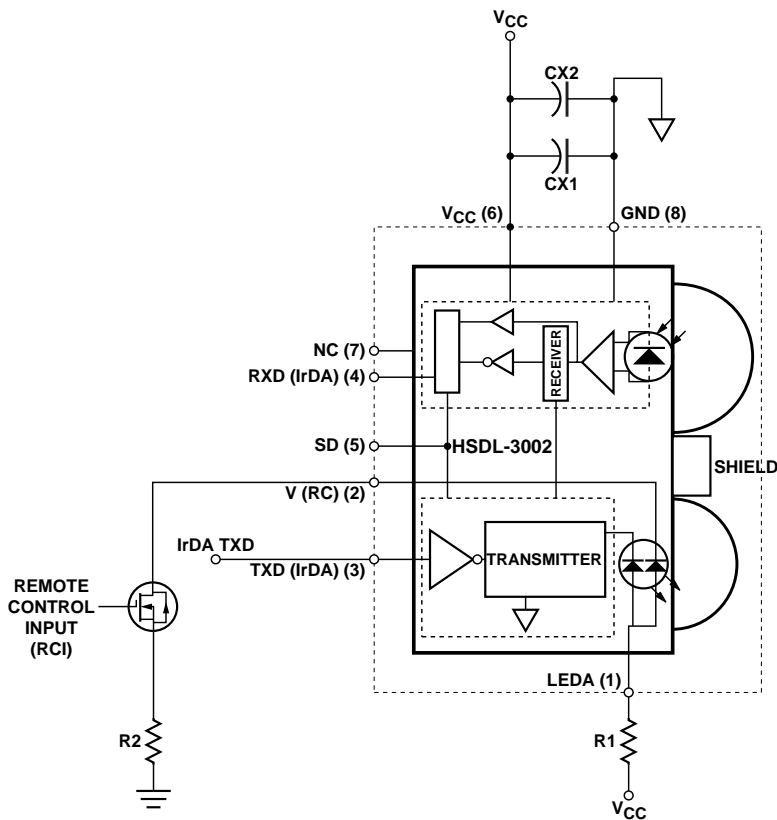

Figure 1. Functional block diagram of HSDL-3002.

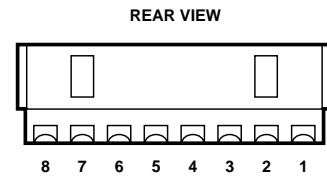

Figure 2. Rear view diagram with pin-out.

## I/O Pins Configuration Table

Pin	Symbol	I/O	Description	Notes
1	LED A	I	IR and Remote Control LED Anode	Tied through external resistor, R1, to regulate $V_{CC}$ from 2.7 to 5.5 Volt
2	V(RC)	I	Remote Control LED Cathode	Connected to an external switching transistor. Do not float the input pin of the switching transistor.
3	TXD (IrDA)	I	IrDA Transmitter Data Input. Active High	Logic high turns on the LED. If held high longer than $\sim 50 \mu\text{s}$ , the LED is turned off. TXD (IrDA) must be driven either high or low. DO NOT leave the pin floating.
4	RXD (IrDA)	O	IrDA Receiver Data Output. Active Low	Output is at low pulse response when light pulse is seen.
5	SD	I	Shutdown. Active High	Complete shutdown TXD(IrDA), RXD(IrDA), and PIN diode
6	$V_{CC}$	I	Supply Voltage	Regulated, 2.7 to 5.5 Volt
7	NC	-	No internal connection	
8	GND	I	Connect to system ground	Connect to system ground
-	SHIELD	-	EMI Shield	Connect to system ground via a low inductance trace. For best performance, do not connect to GND directly at the part.

## Recommended Application Circuit Components

Component	Recommended Value
R1 <sup>[1]</sup>	2.2 $\Omega \pm 5\%$ , 0.25 Watt for $2.7 \leq V_{CC} \leq 3.3 \text{ V}$ 2.7 $\Omega \pm 5\%$ , 0.25 Watt for $3.0 \leq V_{CC} \leq 3.6 \text{ V}$ 6.8 $\Omega \pm 5\%$ , 0.25 Watt for $4.5 \leq V_{CC} \leq 5.5 \text{ V}$
R2	0 $\Omega$ , 0.25 Watt for $4.5 \leq V_{CC} \leq 5.5 \text{ V}$
CX1 <sup>[2]</sup>	0.47 $\mu\text{F} \pm 20\%$ , X7R Ceramic
CX2 <sup>[3]</sup>	6.8 $\mu\text{F} \pm 20\%$ , Tantalum
Q1	N-Channel Logic Level MOSFET (Philip's BSH103) with less than 1 $\Omega$ 'ON' resistance

### Notes:

- R1 is used to optimize the performance of the 870 nm LED, while R2 is the current limiting resistor for the 940 nm RC LED.
- CX1 must be placed within 0.7 cm of HSDL-3002 to obtain optimum noise immunity.
- In environment with noisy power supplies, supply rejection can be enhanced by including CX2 as shown in Figure 1.

## Transceiver I/O Truth Table

Transceiver Mode	Shutdown	Inputs			Outputs		
		IrDA (TXD)	Remote Control Input	EI	IR LED	RC LED	RXD
Active	0	0	0	High <sup>[4]</sup>	Off	Off	Low <sup>[5]</sup>
Active	0	0	0	Low	Off	Off	High
Active	0	0	1	X	Off	On	Not Valid
Active	0	1	0	X	On	Off	Not Valid
Active	0	1	1	X	On	On	Not Valid
Shutdown	1	X <sup>[6]</sup>	X <sup>[6]</sup>	Low	Not Valid	Not Valid	Not Valid

X = Don't Care      EI = In-Band Infrared Intensity at detector

### Notes:

4. In-Band EI  $\leq$  115.2 kb/s.

5. Logic Low is a pulsed response. The condition is maintained for duration dependent on the pattern and strength of the incident intensity.

6. To maintain low shutdown current, TXD need to be driven high or low and not left floating. The Remote Control Input should be tied low.

**CAUTION:** The BiCMOS inherent to this design of this component increases the component's susceptibility to damage from electrostatic discharge (ESD). It is advised that normal static precautions be taken in handling and assembly of this component to prevent damage and/or degradation, which may be induced by ESD.

## Absolute Maximum Ratings

For implementations where case to ambient thermal resistance is  $\leq$  50°C/W.

Parameter	Symbol	Min.	Max.	Units	Conditions
Storage Temperature	T <sub>S</sub>	-40	100	°C	
Operating Temperature	T <sub>A</sub>	-20	70	°C	
LED Supply Voltage	V <sub>LED</sub>	0	7	V	
Supply Voltage	V <sub>CC</sub>	0	7	V	
Output Voltage: RXD	V <sub>O</sub>	-0.5	7	V	
LED Current Pulse Amplitude	I <sub>LED</sub>		500	mA	$\leq$ 90 $\mu$ s Pulse Width $\leq$ 20% duty cycle

## Recommended Operating Conditions

Parameter	Symbol	Min.	Max.	Units	Conditions
Operating Temperature	T <sub>A</sub>	-20	70	°C	
Supply Voltage	V <sub>CC</sub>	2.7	5.5	V	
Logic Input Voltage for TXD	Logic High	V <sub>IH</sub>	2/3 V <sub>CC</sub>	V <sub>CC</sub>	V
	Logic Low	V <sub>IL</sub>	0	1/3 V <sub>CC</sub>	V
Receiver Input Irradiance	Logic High	E <sub>IH</sub>	0.0081	500	mW/cm <sup>2</sup> For in-band signals $\leq$ 115.2 kbps <sup>[7]</sup>
	Logic Low	E <sub>IL</sub>		0.3	mW/cm <sup>2</sup> For in-band signals <sup>[7]</sup>
TXD Pulse Width (SIR)	t <sub>TPW</sub> (SIR)	1.5	1.6	$\mu$ s	t <sub>pw</sub> (TXD) = 1.6 $\mu$ s at 115.2 kbps
Receiver Data Rate		9.6	115.2	kbps	

## Electrical & Optical Specifications

Specifications (Min. & Max. values) hold over the recommended operating conditions unless otherwise noted. Unspecified test conditions may be anywhere in their operating range. All typical values (Typ.) are at 25°C with V<sub>CC</sub> set to 3.0 V unless otherwise noted.

Parameter	Symbol	Min.	Typ.	Max.	Units	Conditions	
<b>Receiver</b>							
Viewing Angle	2θ <sub>1/2</sub>	30			°		
Peak Sensitivity Wavelength	λ <sub>p</sub>		875		nm		
RXD Output Voltage	Logic High	V <sub>OH</sub>	V <sub>CC</sub> - 0.2	V <sub>CC</sub>	V	I <sub>OH</sub> = -200 μA, EI ≤ 0.3 μW/cm <sup>2</sup>	
	Logic Low	V <sub>OL</sub>	0	0.4	V		
RXD Pulse Width (SIR) <sup>[8]</sup>	t <sub>RPW</sub> (SIR)	1		7.5	μs	θ <sub>1/2</sub> ≤ 15°, C <sub>L</sub> = 9 pF	
RXD Rise and Fall Times	t <sub>r</sub> , t <sub>f</sub>		25	100	ns	C <sub>L</sub> = 9 pF	
Receiver Latency Time <sup>[9]</sup>	t <sub>L</sub>		25	50	μs	EI = 4 μW/cm <sup>2</sup>	
Receiver Wake Up Time <sup>[10]</sup>	t <sub>RW</sub>		18	100	μs	EI = 10 mW/cm <sup>2</sup>	
<b>IR Transmitter</b>							
IR Radiant Intensity	I <sub>EH</sub>	10	40		mW/sr	I <sub>LEDA</sub> = 350 mA, θ <sub>1/2</sub> ≤ 15°, TXD ≥ V <sub>IH</sub> , T <sub>A</sub> = 25°C, V(RCI) ≤ V <sub>IL</sub>	
IR Viewing Angle	2θ <sub>1/2</sub>	30		60	°		
IR Peak Wavelength	λ <sub>p</sub>		875		nm		
TXD Logic Levels	High	V <sub>IH</sub>	2/3 V <sub>CC</sub>	V <sub>CC</sub>	V		
	Low	V <sub>IL</sub>	0	1/3 V <sub>CC</sub>	V		
TXD Input Current	High	I <sub>H</sub>		0.02	1	μA	V <sub>I</sub> ≥ V <sub>IH</sub>
	Low	I <sub>L</sub>	-1	-0.02	1	μA	0 ≤ V <sub>I</sub> ≤ V <sub>IL</sub>
LED Current	Shutdown	I <sub>VLED</sub>		20	1000	nA	V <sub>I</sub> (SD) ≥ V <sub>IH</sub> , T <sub>A</sub> = 25°C
Wakeup Time <sup>[11]</sup>	t <sub>TW</sub>		30	100	ns		
Maximum Optical PW <sup>[12]</sup>	t <sub>PW(Max)</sub>		25	50	μs		
TXD Rise and Fall Time (Optical)	t <sub>r</sub> , t <sub>f</sub>			600	ns		
LED Anode on State Voltage	V <sub>ON</sub> (LEDA)			2.2	V	I <sub>LEDA</sub> = 350 mA, V <sub>I</sub> (TXD) ≥ V <sub>IH</sub> , V(RCI) ≤ V <sub>IL</sub>	
<b>RC Transmitter</b>							
Remote Control (RC) Radiant Intensity <sup>[13]</sup>	I <sub>EH</sub>	5	20		mW/sr	I <sub>LEDA</sub> = 400 mA, θ <sub>1/2</sub> ≤ 15°, TXD ≤ V <sub>IL</sub> , T <sub>A</sub> = 25°C, V(RCI) ≥ V <sub>IH</sub>	
RC Viewing Angle	2θ <sub>1/2</sub>	30		60	°		
RC Peak Wavelength	λ <sub>p</sub>		940		nm		
<b>Transceiver</b>							
Input Current	High	I <sub>H</sub>		0.01	1	μA	V <sub>I</sub> ≥ V <sub>IH</sub>
	Low	I <sub>L</sub>	-1	-0.02	1	μA	0 ≤ V <sub>I</sub> ≤ V <sub>IL</sub>
Supply Current	Shutdown	I <sub>CC1</sub>		0.01	1	μA	V <sub>SD</sub> ≥ V <sub>CC</sub> - 0.5; T <sub>A</sub> = 25°C
	Idle	I <sub>CC2</sub>		290	450	μA	V <sub>I</sub> (TXD) ≤ V <sub>IL</sub> , EI = 0
	Active	I <sub>CC3</sub>		2	8	mA	V <sub>I</sub> (TXD) ≥ V <sub>IL</sub>

**Notes:**

7. An in-band optical signal is a pulse/sequence where the peak wavelength,  $\lambda_p$ , is defined as  $850 \text{ nm} \leq \lambda_p \leq 900 \text{ nm}$ , and the pulse characteristics are compliant with the IrDA Serial Infrared Physical Layer Link Specification.
8. For in band signals 2.4 kbps to 115.2 kbps where  $3.6 \mu\text{W}/\text{cm}^2 \leq E_I \leq 500 \text{ mW}/\text{cm}^2$ .
9. Latency is defined as the time from the last TXD light output pulse until the receiver has recovered full sensitivity.
10. Receiver Wake up time is measured from  $V_{CC}$  power on to valid RXD output.
11. Transmitter wake up time is measured from  $V_{CC}$  power on to valid light output in response to a TXD pulse.
12. The optical PW is defined as the maximum time which the LED will turn on, this is to prevent the long turn on time for the LED.
13. The  $V_{IH}$  and  $V_{IL}$ , when used in reference with RCI, depend on the switching transistor used and should obtain from the transistor datasheet.

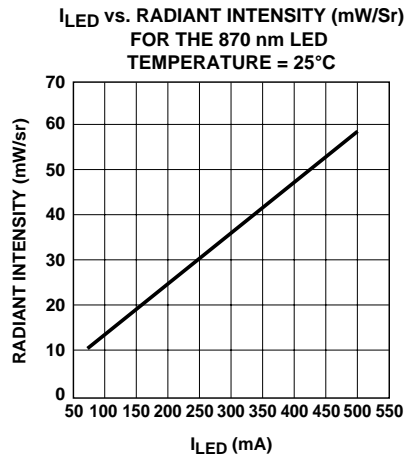

Figure 3. IR LOP vs.  $I_{LED}$ .

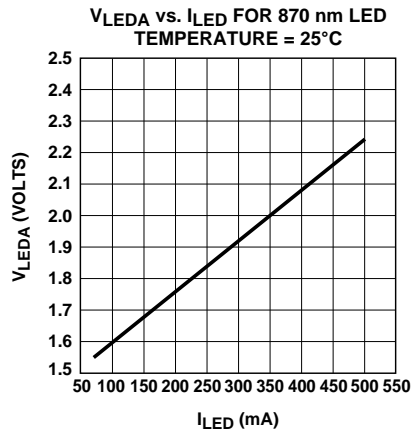

Figure 4. IR  $V_{LED}$  vs.  $I_{LED}$ .

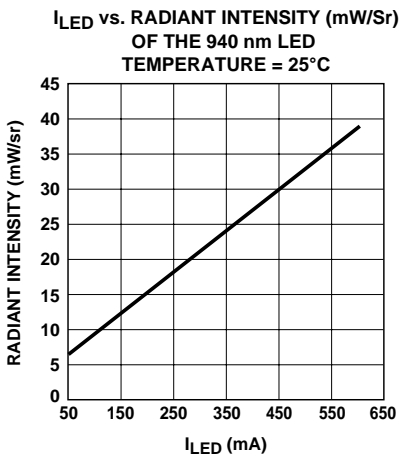

Figure 5. RC LOP vs.  $I_{LED}$ .

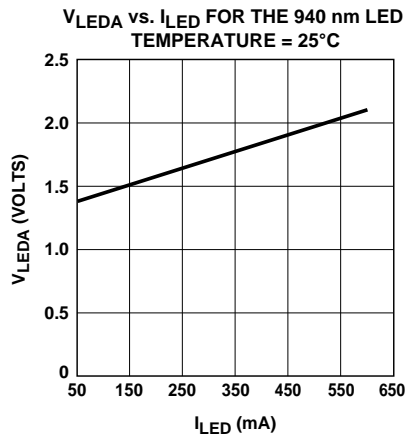

Figure 6. RC  $V_{LED}$  vs.  $I_{LED}$ .

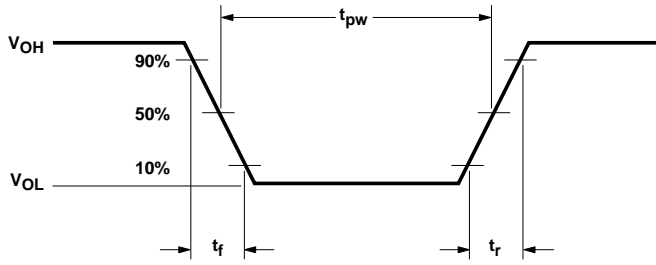

Figure 7. RXD output waveform.

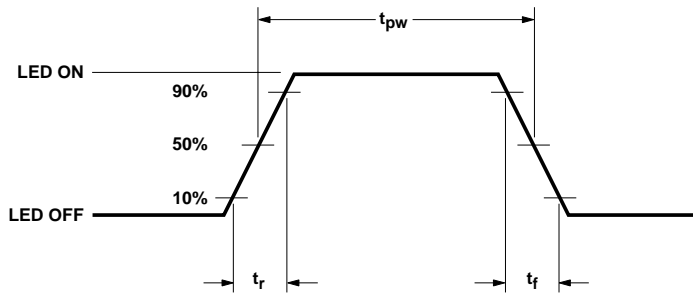

Figure 8. LED optical waveform.

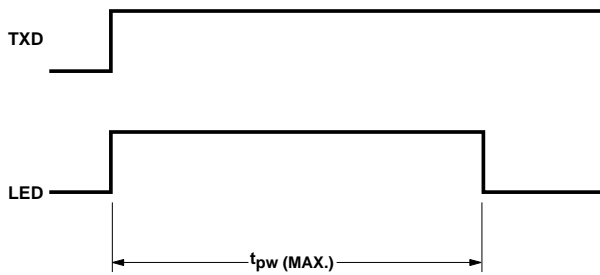

Figure 9. TXD "Stuck ON" protection.

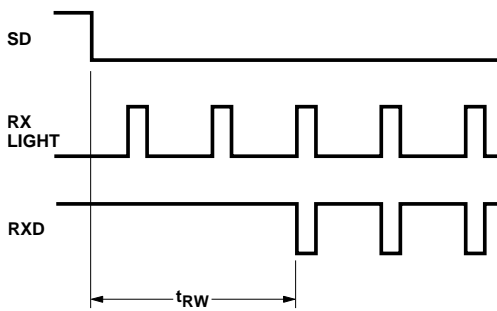

Figure 10. Receiver wakeup time definition.

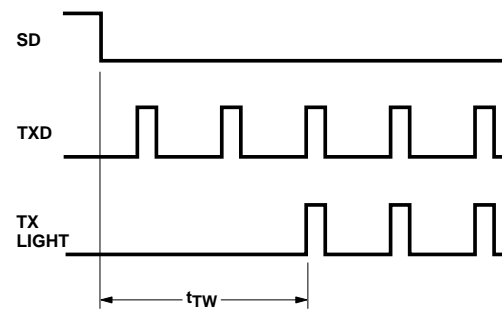

Figure 11. Transmitter wakeup time definition.

# HSDL-3002 Package Outline (with Integrated Shield)

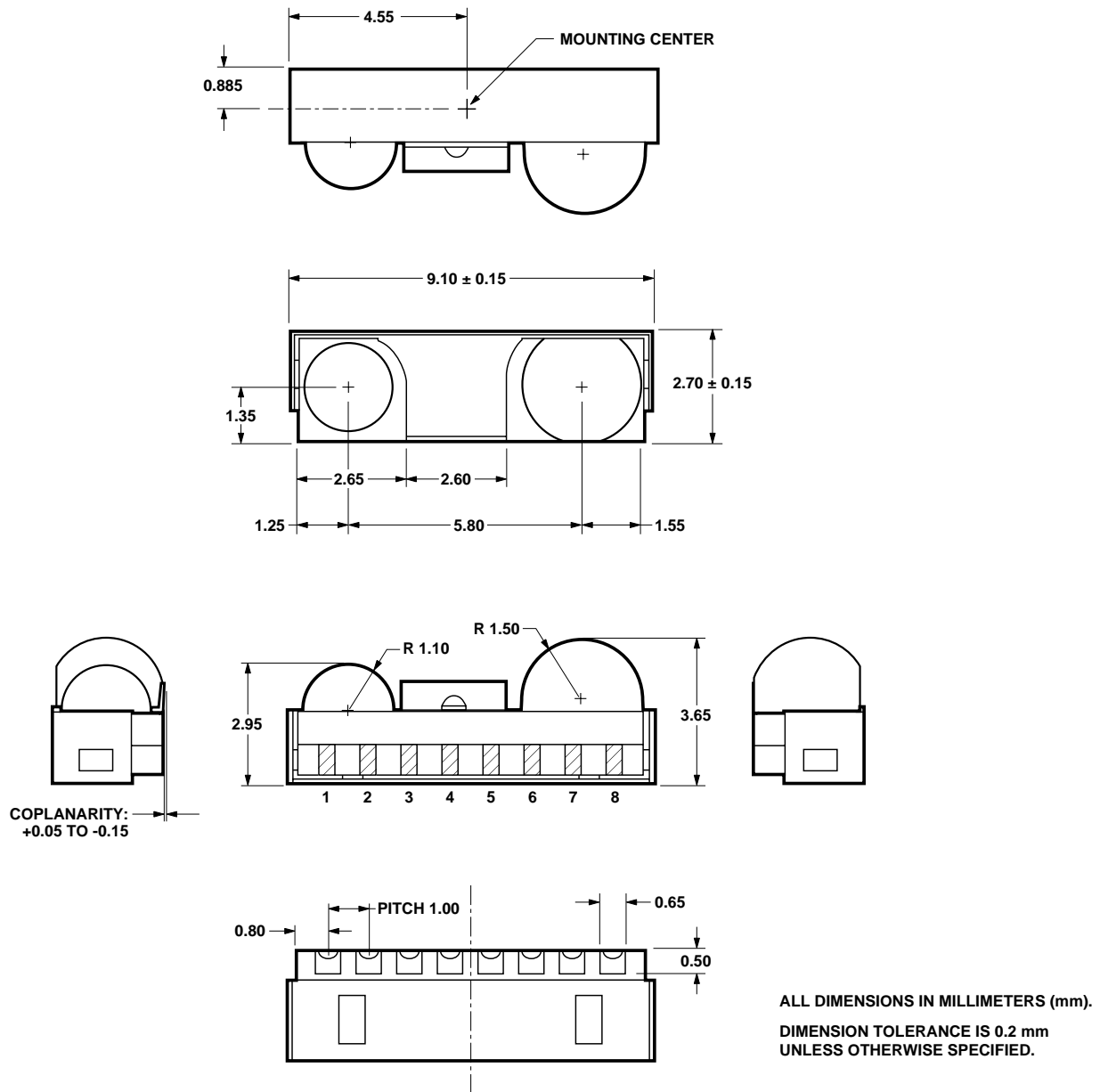

Figure 12. Package outline dimension.

# HSDL-3002 Tape and Reel Dimensions

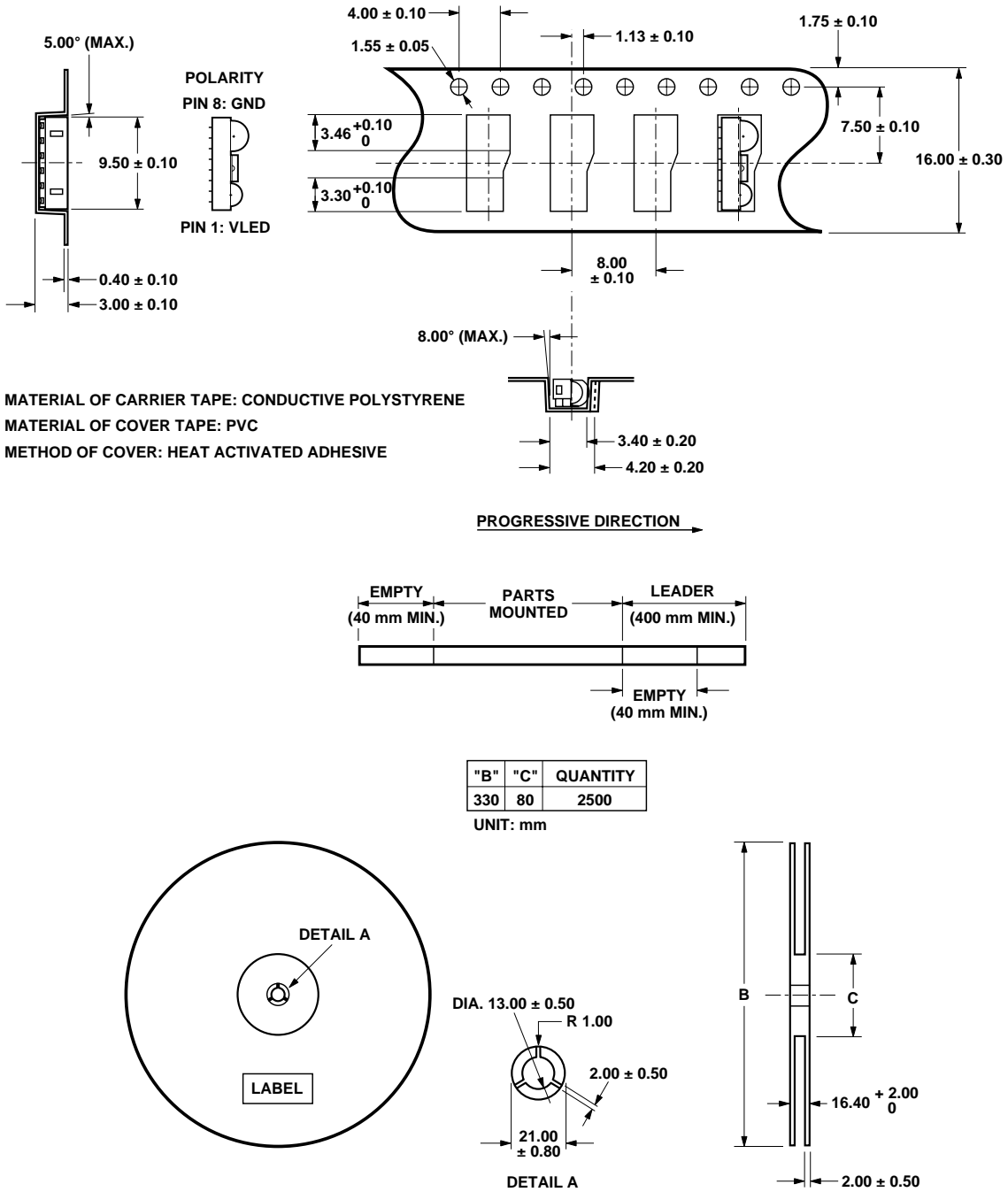

Figure 13. Tape and reel dimensions.

## Moisture Proof Packaging

All HSDL-3002 options are shipped in moisture proof package. Once opened, moisture absorption begins.

This part is compliant to JEDEC Level 4.

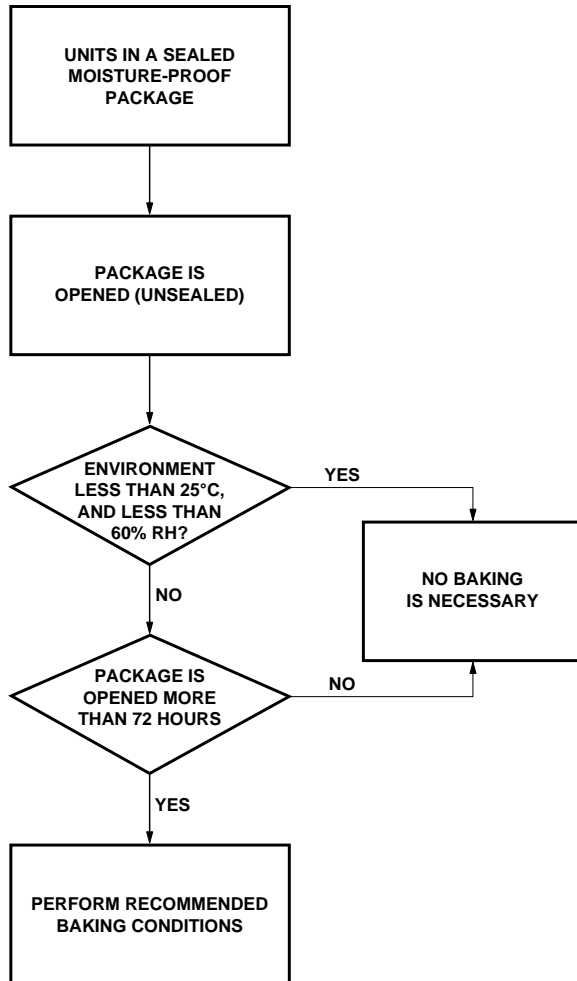

Figure 14. Baking conditions chart.

## Baking Conditions

If the parts are not stored in dry conditions, they must be baked before reflow to prevent damage to the parts.

Package	Temp.	Time
In reels	60°C	≥ 48 hours
In bulk	100°C	≥ 4 hours
	125°C	≥ 2 hours
	150°C	≥ 1 hour

Baking should only be done once.

## Recommended Storage Conditions

Storage Temperature	10°C to 30°C
Relative Humidity	below 60% RH

## Time from Unsealing to Soldering

After removal from the bag, the parts should be soldered within three days if stored at the recommended storage conditions.

## Reflow Profile

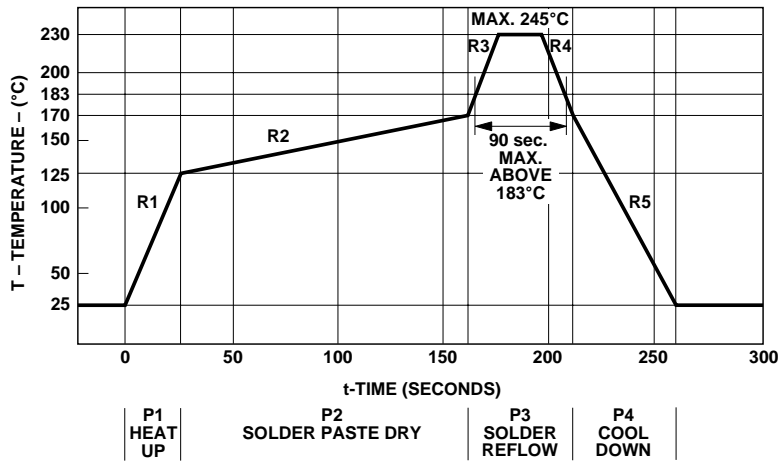

Figure 15. Reflow graph.

Process Zone	Symbol	$\Delta T$	Maximum DT/Dtime
Heat Up	P1, R1	25°C to 125°C	4°C/s
Solder Paste Dry	P2, R2	125°C to 170°C	0.5°C/s
Solder Reflow	P3, R3	170°C to 230°C (245°C at 10 seconds max.)	4°C/s
	P3, R4	230°C to 170°C	-4°C/s
Cool Down	P4, R5	170°C to 25°C	-3°C/s

The reflow profile is a straight-line representation of a nominal temperature profile for a convective reflow solder process. The temperature profile is divided into four process zones, each with different  $\Delta T/\Delta \text{time}$  temperature change rates. The  $\Delta T/\Delta \text{time}$  rates are detailed in the above table. The temperatures are measured at the component to printed circuit board connections.

In **process zone P1**, the PC board and HSDL-3602 castellated I/O pins are heated to a temperature of 125°C to activate the flux in the solder paste. The temperature ramp up rate, R1, is limited to 4°C per second to allow for even heating of both the PC board and HSDL-3602 castellated I/O pins.

**Process zone P2** should be of sufficient time duration (>60 seconds) to dry the solder paste. The temperature is raised to a level just below the liquidus point of the solder, usually 170°C (338°F).

**Process zone P3** is the solder reflow zone. In zone P3, the temperature is quickly raised above the liquidus point of solder to 230°C (446°F) for optimum results. The dwell time above the liquidus point of solder should be between 15 and 90 seconds. It usually takes about 15 seconds to assure proper coalescing of the solder balls into liquid solder and the formation of good solder connections. Beyond a dwell time of 90 seconds, the intermetallic growth within the solder

connections becomes excessive, resulting in the formation of weak and unreliable connections. The temperature is then rapidly reduced to a point below the solidus temperature of the solder, usually 170°C (338°F), to allow the solder within the connections to freeze solid.

**Process zone P4** is the cool down after solder freeze. The cool down rate, R5, from the liquidus point of the solder to 25°C (77°F) should not exceed -3°C per second maximum. This limitation is necessary to allow the PC board and HSDL-3602 castellated I/O pins to change dimensions evenly, putting minimal stresses on the HSDL-3602 transceiver.

# Appendix A : SMT Assembly Application Note

## 1.0 Solder Pad, Mask and Metal Stencil

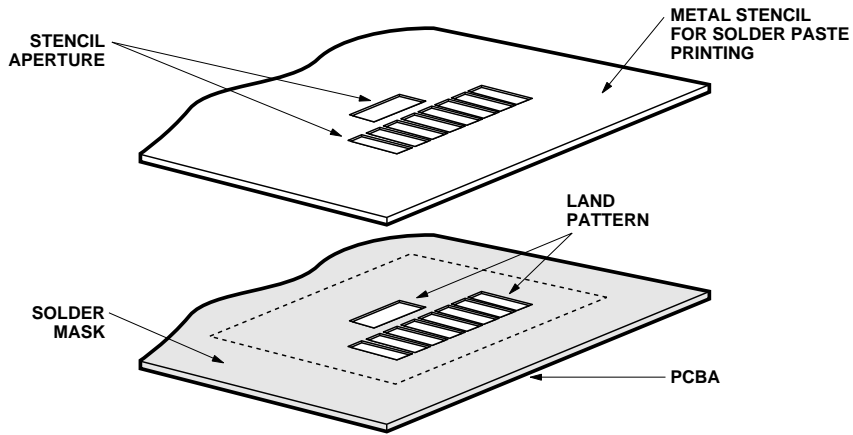

Figure 16. Stencil and PCBA.

## 1.1 Recommended Land Pattern

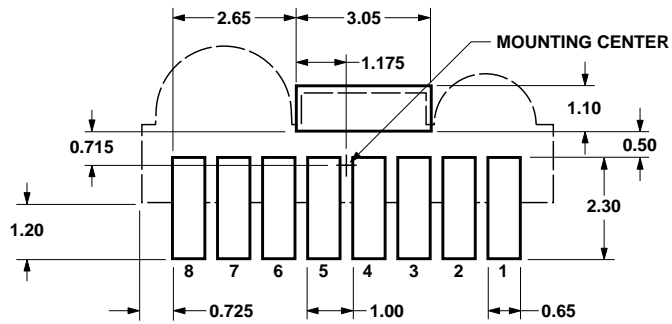

Figure 17. Land pattern.

### 1.2 Recommended Metal Solder Stencil Aperture

It is recommended that only a 0.152 mm (0.006 inches) or a 0.127 mm (0.005 inches) thick stencil be used for solder paste printing. This is to ensure adequate printed solder paste volume and no shorting. See the table below the drawing for combinations of metal stencil aperture and metal stencil thickness that should be used.

Aperture opening for shield pad is 3.05 mm x 1.1 mm as per land pattern.

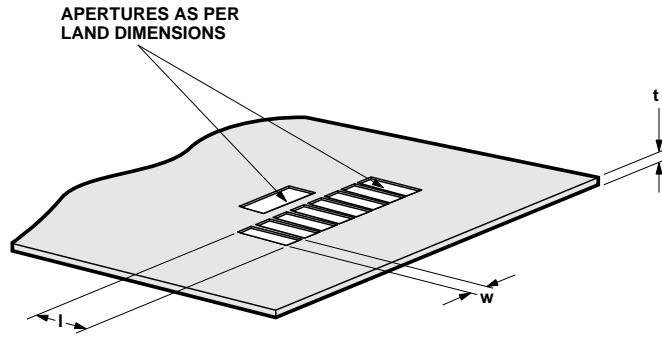

Figure 18. Solder stencil aperture.

Stencil thickness, t (mm)	Aperture size(mm)	
	length, l	width, w
0.152 mm	2.60 ± 0.05	0.55 ± 0.05
0.127 mm	3.00 ± 0.05	0.55 ± 0.05

### 1.3 Adjacent Land Keepout and Solder Mask Areas

Adjacent land keep-out is the **maximum space** occupied by the unit relative to the land pattern. There should be no other SMD components within this area.

The minimum solder resist strip width required to avoid solder bridging adjacent pads is **0.2 mm**.

It is recommended that two fiducial crosses be placed at mid-length of the pads for unit alignment.

**Note:** Wet/Liquid Photo-Imageable solder resist/mask is recommended.

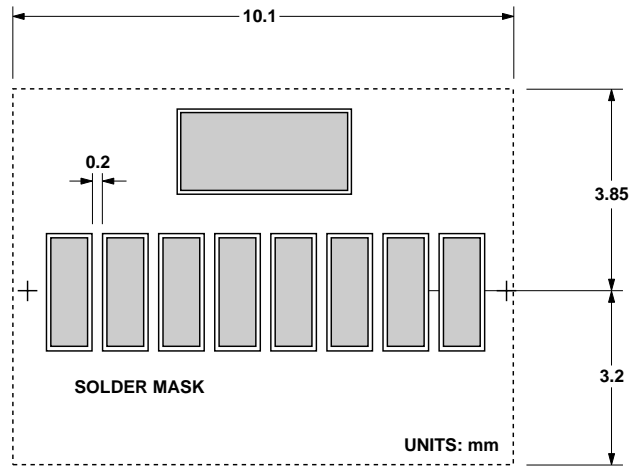
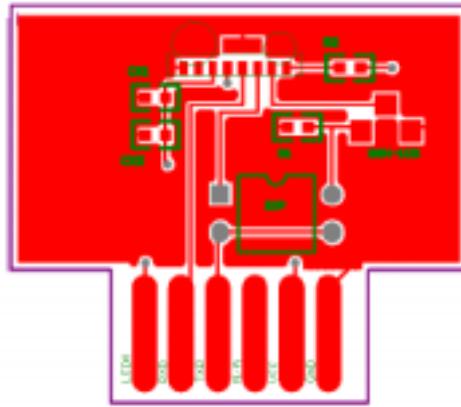

Figure 19. Adjacent land keepout and solder mask areas.

## Appendix B : PCB Layout Suggestion

The following shows an example of a PCB layout that would result in good electrical and EMI performance. Things to note:

1. The ground plane should be continuous under the part, but should not extend under the shield trace.
2. The shield trace is a wide, low inductance trace back to the system ground.
3. The AGND pin should be connected to the ground plane and not to the shield tab.
4. C1 and C2 are optional supply filter capacitors; they may be left out if a clean power supply is used.
5.  $V_{LED}$  can be connected to either unfiltered or unregulated power supply. If  $V_{LED}$  and  $V_{CC}$  share the same power supply and C1 is used, the connection should be before the current limiting resistor R2. In a noisy environment, supply rejection can be enhanced by including C2 as well.



Top View

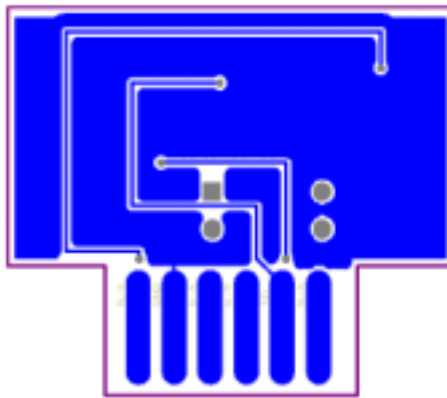

Bottom View

The layout corresponds to the following application circuit diagram.

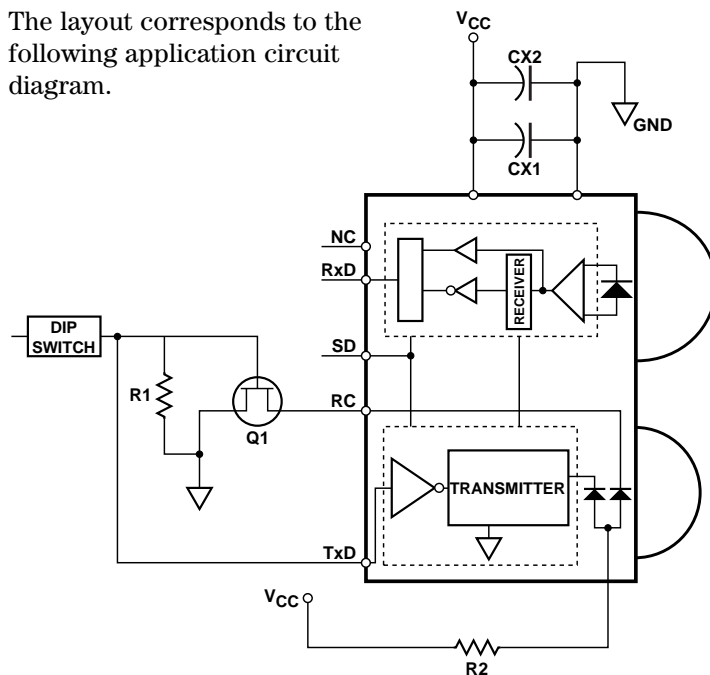

R2 is the current limiting resistor, while R1 is a weak pull down resistor for the input of the switching MOSFET. The DIP switch is used to select between driving the 875 nm or 940 nm LED.

Figure 20. PCB layout suggestion.

## Appendix C : General Application Guide for the HSDL-3002 Infrared IrDA® Compliant 115.2 Kb/s Transceiver

### Description

The HSDL-3002, a wide voltage operating range infrared transceiver is a low-cost and small form factor device that is designed to address the mobile

computing market such as PDAs, as well as small embedded mobile products such as digital cameras and cellular phones. It also includes a 940 nm LED to support universal remote control applications. It is fully compliant to IrDA 1.4 low power specification from 9.6 kb/s to 115.2 kb/s, and supports most remote control codes. The design of the HSDL-

3002 also includes the following unique features:

- An additional spectrally suited 940 nm LED
- Low passive component count.
- Shutdown mode for low power consumption requirement.

### Selection of Resistor R1

Resistor R1 should be selected to provide the appropriate peak pulse LED current over different ranges of  $V_{CC}$  as shown in the table below.

Recommended R1	$V_{CC}$	Intensity	Minimum Peak Pulse LED Current	Conditions
2.2 $\Omega$	3.0 V	40 mW/sr	350 mA	Turn on 870 nm LED only $TxD \geq V_{IH}$ , $V(RC) \leq V_{IL}$
		20 mW/sr	400 mA	Turn on 940 nm LED only $TXD \leq V_{IL}$ , $V(RC) \geq V_{IH}$

The resistor value chosen above is for optimal IrDA operation. For optimized remote control performance, it is recommended to turn on both the 870 nm and 940 nm LEDs. Moreover, separate power control feature can be incorporated for remote control operation by implementing device as shown in Figure 3.

### Interface to Recommended I/O Chips

The HSDL-3002's TXD data input is buffered to allow for CMOS drive levels. No peaking circuit or capacitor is required. Data rate from 9.6 kb/s up to 115.2 kb/s is available at the RXD pin. The  $V(RC)$ , pin 2, in conjunction with  $TxD$  (IrDA), pin 3, can be used to send remote control codes. Pin 2

is driven through a switching FET transistor with a very low on-resistance capable of driving 400 mA of current for remote control operation.

The block diagram below shows how the IrDA port fits into a mobile phone and PDA platform.

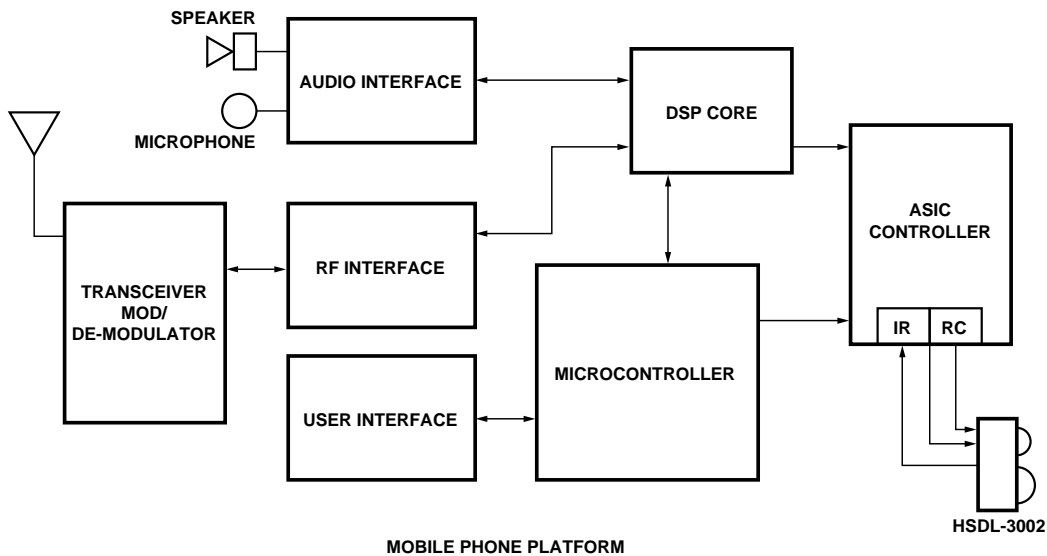

Figure 21. IR layout in mobile phone platform.

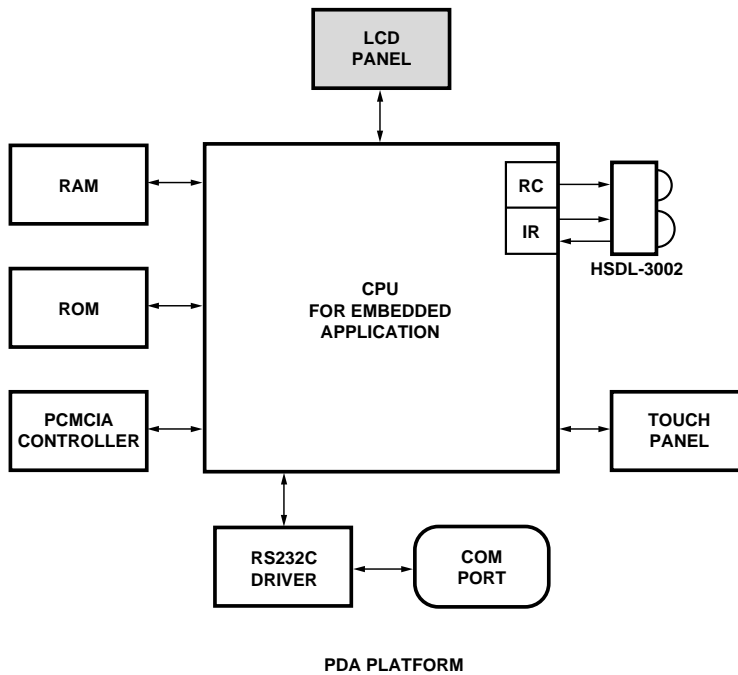

Figure 22. IR layout in PDA platform.

The link distance testing was done using typical HSDL-3002 units with National Semiconductor's PC87109 3 V Super I/O controller and SMC's FDC37C669 and FDC37N769 Super I/O controllers. An IrDA link distance of up to 100 cm was demonstrated.

### Remote Control Operation

HSDL-3002 comes with an additional spectrally suited 940 nm LED for remote control applications. Remote control applications are not governed by any standards, owing to which there are numerous remote control codes in the market. Each of these standards results in receiver modules with different sensitivities, depending on the carrier frequencies and responsivity to the incident light wavelength.

Based on a survey of some commonly used remote control receiver modules, the irradiance is found to be in the range of 0.05~0.07  $\mu\text{W}/\text{cm}^2$ . Based on a typical irradiance of 0.075  $\mu\text{W}/\text{cm}^2$  and turning on both 870 nm and 940 nm LEDs, a typical link distance of 6 m is achieved. For a more exhaustive note on implementing remote control using HSDL-3002, please refer to the application note.

## Appendix D : Window Designs for HSDL-3002

### Optical port dimensions for HSDL-3002

To ensure IrDA compliance, some constraints on the height and width of the window exist. The minimum dimensions ensure that the IrDA cone angles are met without vignetting. The maximum dimensions minimize the effects of stray light. The minimum size corresponds to a cone angle of 30° and the maximum size corresponds to a cone angle of 60°.

In the figure below, X is the width of the window, Y is the height of the window and Z is the distance from the HSDL-3002 to the back of the window. The distance from the center of the LED lens to the center of the photodiode lens, K, is 5.8 mm. The equations for computing the window dimensions are as follows:

$$X = K + 2*(Z+D)*\tan A$$

$$Y = 2*(Z+D)*\tan A$$

The above equations assume that the thickness of the window is negligible compared to the distance of the module from the back of the window (Z). If they

are comparable, Z' replaces Z in the above equation. Z' is defined as

$$Z' = Z + t/n$$

where 't' is the thickness of the window and 'n' is the refractive index of the window material.

The depth of the LED image inside the HSDL-3002, D, is 8.6 mm. 'A' is the required half angle for viewing. For IrDA compliance, the minimum is 15° and the maximum is 30°.

Assuming the thickness of the window to be negligible, the equations result in the following tables and graphs:

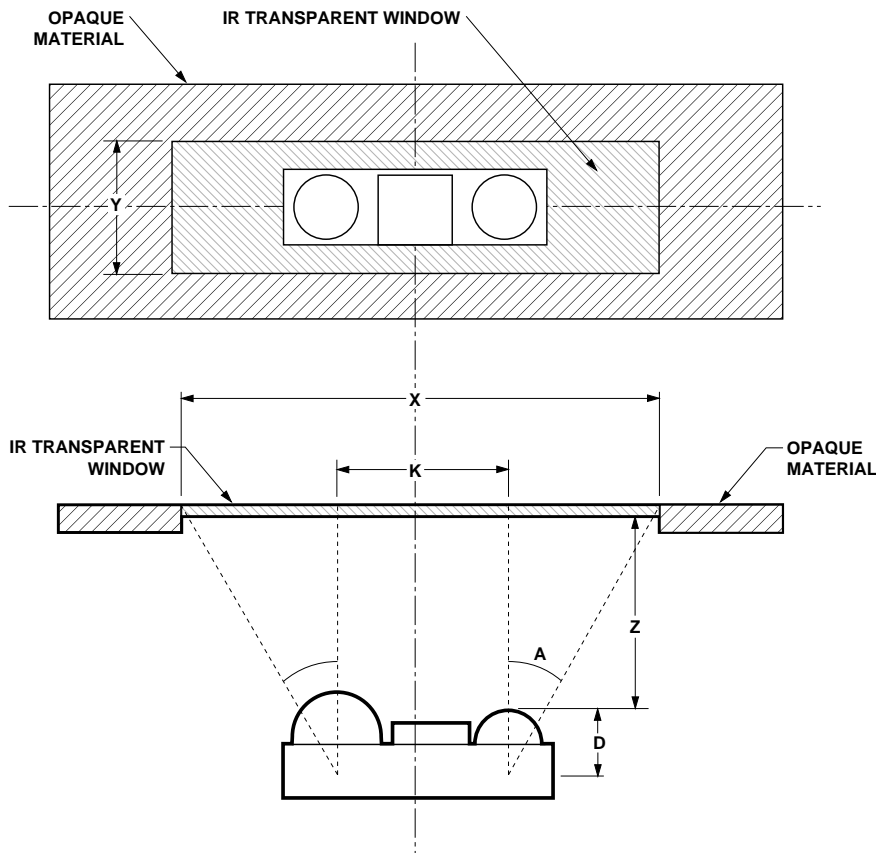

Figure 23. Window design diagram.

Module Depth (z) mm	Aperture Width (x, mm)		Aperture Height (y, mm)	
	Max.	Min.	Max.	Min.
0	15.73	10.41	9.93	4.61
1	16.89	10.94	11.09	5.14
2	18.04	11.48	12.24	5.68
3	19.19	12.02	13.39	6.22
4	20.35	12.55	14.55	6.75
5	21.5	13.09	15.7	7.29
6	22.66	13.62	16.86	7.82
7	23.81	14.16	18.01	8.36
8	24.97	14.7	19.17	8.90
9	26.12	15.23	20.32	9.43

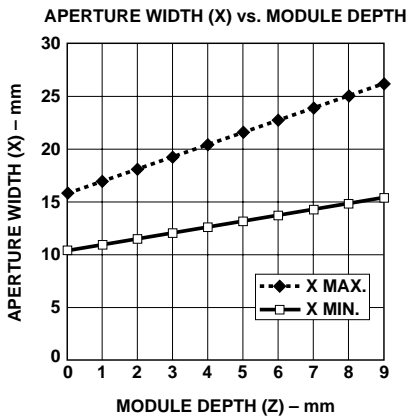

Figure 24. Aperture width (X) vs. module depth.

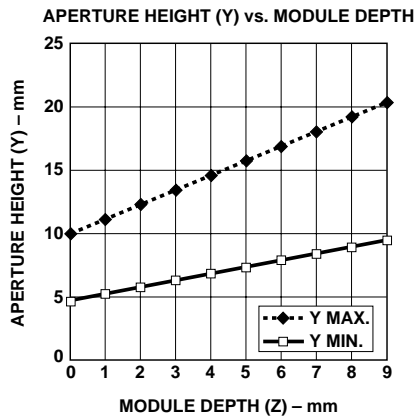

Figure 25. Aperture height (Y) vs. module depth.

## Window Material

Almost any plastic material will work as a window material. Polycarbonate is recommended. The surface finish of the plastic should be smooth, without any

texture. An IR filter dye may be used in the window to make it look black to the eye, but the total optical loss of the window should be 10% or less for best optical performance. Light loss should be measured at 875 nm.

The recommended plastic materials for use as a cosmetic window are available from General Electric Plastics.

## Recommended Plastic Materials

Material #	Light Transmission	Haze	Refractive Index
Lexan 141L	88%	1%	1.586
Lexan 920A	85%	1%	1.586
Lexan 940A	85%	1%	1.586

Note: 920A and 940A are more flame retardant than 141L.  
Recommended Dye: Violet #21051 (IR transmittant above 625 nm)

## Shape of the Window

From an optics standpoint, the window should be flat. This ensures that the window will not alter either the radiation pattern of the LED, or the receive pattern of the photodiode.

If the window must be curved for mechanical or industrial design reasons, place the same curve on the back side of the window that has an identical radius as the front side. While this will not completely eliminate the lens effect of the front curved surface, it will significantly reduce the effects. The amount of change in the radiation pattern is dependent

upon the material chosen for the window, the radius of the front and back curves, and the distance from the back surface to the transceiver. Once these items are known, a lens design can be made which will eliminate the effect of the front surface curve.

The following drawings show the effects of a curved window on the radiation pattern. In all cases, the center thickness of the window is 1.5 mm, the window is made of polycarbonate plastic, and the distance from the transceiver to the back surface of the window is 3 mm.

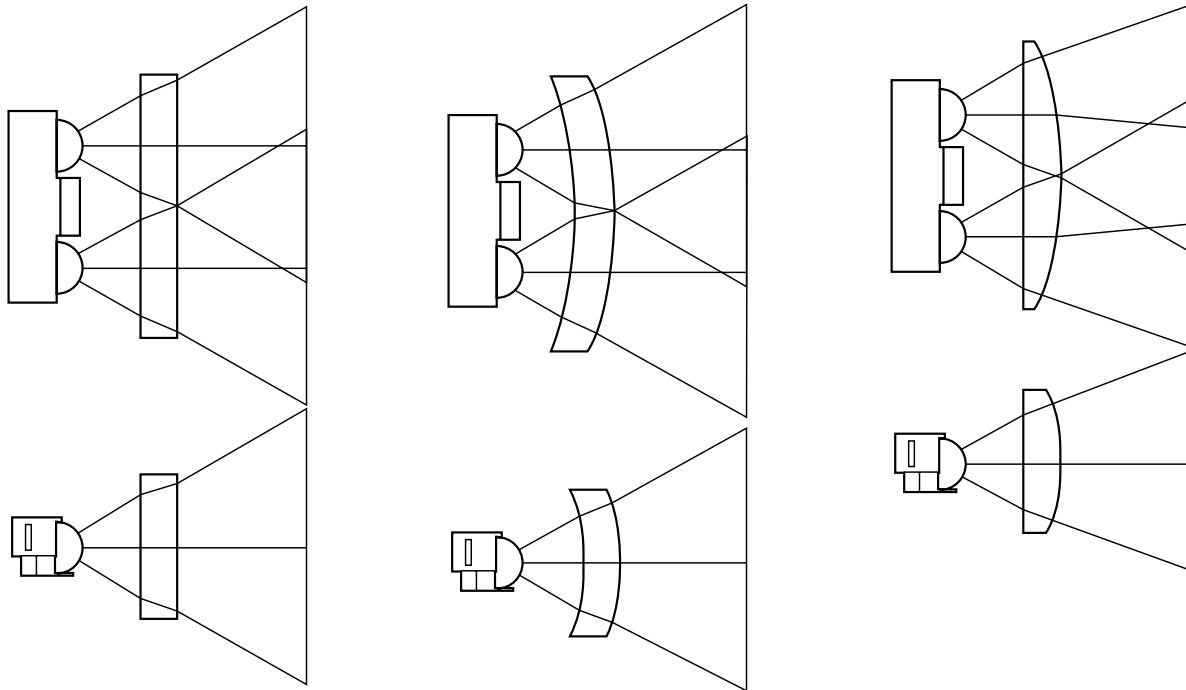

**Flat Window**  
(First choice)

**Curved Front and Back**  
(Second choice)

**Curved Front, Flat Back**  
(Do not use)

Figure 26. Shape of windows.

For product information and a complete list of distributors, please go to our website: [www.avagotech.com](http://www.avagotech.com)

Avago, Avago Technologies, and the A logo are trademarks of Avago Technologies, Limited in the United States and other countries.  
Data subject to change. Copyright © 2006 Avago Technologies Pte. All rights reserved. Obsoletes 5988-7424EN  
5988-4165EN May 27, 2006

