

CDK1300

8-bit, 250 MSPS ADC with Demuxed Outputs

CDK1300 8-bit, 250 MSPS ADC with Demuxed Outputs Rev 1B

FEATURES

- TTL/CMOS/PECL input logic compatible
- High conversion rate: 250 MSPS
- Single +5V power supply
- Very low power dissipation: 310mW
- 220MHz full power bandwidth
- Power-down mode
- +3.0V/+5.0V (LVCMOS) digital output logic compatibility
- Single/demuxed output ports selectable

APPLICATIONS

- RGB video processing
- Digital communications
- High-speed instrumentation
- Digital Sampling Oscilloscopes (DSO)
- Projection display systems

General Description

The CDK1300 is a high-speed, 8-bit analog-to-digital converter implemented in an advanced BiCMOS process. An advanced folding and interpolating architecture provides both a high conversion rate and very low power dissipation of only 310mW. The analog inputs can be operated in either single-ended or differential input mode. A 2.5V common mode reference is provided on chip for the single-ended input mode to minimize external components.

The CDK1300 digital outputs are demuxed (double-wide) with both dual-channel and single-channel selectable output modes. Demuxed mode supports either parallel aligned or interleaved data output. The output logic is both +3.0V and +5.0V compatible. The CDK1300 is available in a 44-lead TQFP surface mount package over the industrial temperature range of -40°C to +85°C.

Block Diagram

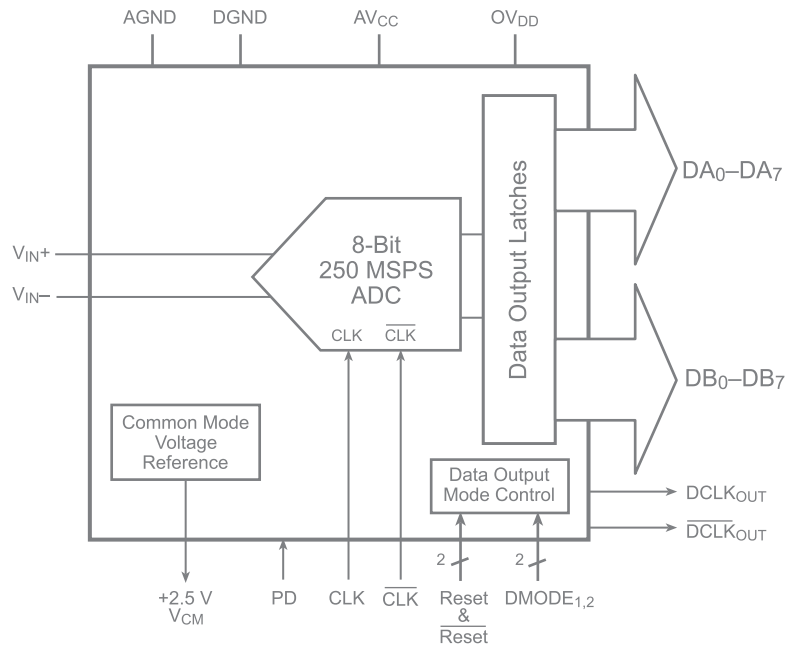

Ordering Information

Part Number	Package	Pb-Free	RoHS Compliant	Operating Temperature Range	Packaging Method
CDK1300ITQ44	TQFP-44	Yes	Yes	-40°C to +85°C	Rail

Moisture sensitivity level for all parts is MSL-1.

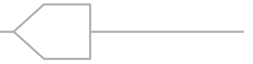

Absolute Maximum Ratings

The safety of the device is not guaranteed when it is operated above the "Absolute Maximum Ratings". The device should not be operated at these "absolute" limits. Adhere to the "Recommended Operating Conditions" for proper device function. The information contained in the Electrical Characteristics tables and Typical Performance plots reflect the operating conditions noted on the tables and plots.

Parameter	Min	Max	Unit
Supply Voltage			
AV_{CC}		+6	V
OV_{DD}		+6	V
Input Voltages			
Analog inputs	-0.5V	$V_{CC} + 0.5V$	V
Digital inputs	-0.5V	$V_{CC} + 0.5V$	V

Reliability Information

Parameter	Min	Typ	Max	Unit
Storage Temperature Range	-65		+125	°C

Recommended Operating Conditions

Parameter	Min	Typ	Max	Unit
Operating Temperature Range	-40		+85	°C



Electrical Characteristics

($T_A = T_{Min}$ to T_{Max} , $AV_{CC} = +5V$, $OV_{DD} = +5V$, $f_{clk} = 250MHz$, 50% duty cycle, $f_{IN} = 70MHz$, dual channel mode; unless otherwise noted)

Symbol	Parameter	Conditions	Min	Typ	Max	Units
	Resolution			8		bits
DC Performance						
DLE	Differential Linearity Error	+25°C, $f_{IN} = 1KHz$		-0.7/1.05		LSB
		-40°C to +85°C, $f_{IN} = 1KHz$		-0.95/+1.5		LSB
ILE	Integral Linearity Error	+25°C, $f_{IN} = 1KHz$		±1.7		LSB
		-40°C to +85°C, $f_{IN} = 1KHz$		±2.25		LSB
	No Missing Codes	@250 MSPS, $f_{IN} = 1KHz$	Guaranteed			
Analog Input						
	Input Voltage Range	with respect to V_{IN-}		±470		mV _{pp}
V_{CM}	Input Common Mod ⁽²⁾		2.3	2.5	2.0	V
	Input Bias Current	+25°C		10		µA
	Input Resistance	+25°C		50		kΩ
	Input Capacitance	+25°C		4		pF
	Input Bandwidth	+25°C (-3dB of FS)		220		MHz
	Gain Error	+25°C		2		%
	Offset Error	+25°C		±10		mV
PSRR	Offset Power Supply Rejection Ratio	$AV_{CC} = 5V \pm 0.25V$		0.5		mV/V
Timing Characteristics						
	Conversion Rate ⁽¹⁾		250			MSPS
t_{pd1}	Output Delay (Clock-to-Data) ⁽²⁾	-40°C to +85°C	6	8	10.5	ns
	Output Delay Tempco			22		ps/°C
t_{ap}	Aperture Delay Time			0.5		ns
	Aperture Jitter Time			2.0		ps-RMS
	Pipeline Delay (Latency)					
	Single Channel Mode			2.5		Cycle
	Demuxed Interleaved Mode			2.5		Cycle
	Demuxed Parallel Mode					
	Channel B			2.5		Cycle
	Channel A			3.5		Cycle
	CLK to DCLK _{OUT} Delay Time					
t_{pd2}	Single Channel Mode ⁽²⁾		4	6	7	ns
t_{pd3}	Dual Channel Mode ⁽²⁾		5.3	6.16	7.8	ns
Dynamic Performance						
ENOB	Effective Number of Bits	$f_{IN} = 70MHz, +25°C^{(1)}$	5.8	6.4		Bits
		$f_{IN} = 70MHz, -40°C$ to +85°C ⁽²⁾	5.5	6.0		Bits
SNR	Signal-to-Noise Ratio	$f_{IN} = 70MHz, +25°C^{(1)}$	42	43		dB
		$f_{IN} = 70MHz, -40°C$ to +85°C ⁽²⁾	36	40		dB
THD	Total Harmonic Distortion	$f_{IN} = 70MHz, +25°C^{(1)}$		-43	-40	dB
		$f_{IN} = 70MHz, -40°C$ to +85°C ⁽²⁾		-42	-37	dB
SINAD	Signal-to-Noise and Distortion	$f_{IN} = 70MHz, +25°C^{(1)}$	37	40		dB
		$f_{IN} = 70MHz, -40°C$ to +85°C ⁽²⁾	35	38		dB

Notes:

- 100% production tested at +25°C.
- Parameter is guaranteed (but not tested) by design and characterization data.



Electrical Characteristics

($T_A = T_{Min}$ to T_{Max} , $AV_{CC} = +5V$, $OV_{DD} = +5V$, $f_{clk} = 250MHz$, 50% duty cycle, $f_{IN} = 70MHz$, dual channel mode; unless otherwise noted)

Symbol	Parameter	Conditions	Min	Typ	Max	Units
Power Supply Requirements						
AV_{CC}	Analog Voltage Supply ⁽²⁾		4.75	5.0	5.25	V
OV_{DD}	Digital Voltage Supply ⁽²⁾		2.75		5.25	V
AV_{CC}	Current ⁽¹⁾			62	70	mA
	Power Dissipation ⁽¹⁾	with Internal Voltage Reference		310	350	mW
Common Mode Reference Output						
	Voltage ⁽¹⁾		2.45	2.5	2.55	V
	Voltage Tempco			100		ppm/°C
	Output Impedance	$I_{OUT} = \pm 50\mu A$		1		k Ω
PSRR	Power Supply Rejection Ratio			63		mV/V
Clock and Reset Inputs (Differential and Single-Ended)						
V_{DIFF}	Differential Signal Amplitude ⁽¹⁾		400			mV _{pp}
V_{IHD}	Differential High Input Voltage ⁽²⁾		1.4		5	V
V_{ILD}	Differential Low Input Voltage ⁽²⁾		0		3.9	V
V_{CMD}	Differential Common Mode Input ⁽²⁾		1.2		4.1	V
V_{IH}	Single-Ended High Input Voltage ⁽²⁾		1.8			V
V_{IL}	Single-Ended Low Input Voltage ⁽²⁾				1.2	V
I_{IH}	High Input Current ⁽¹⁾	$V_{ID} = 1.5V$	-100	20	+100	μA
I_{IL}	Low Input Current ⁽¹⁾	$V_{ID} = 1.5V$	-100	20	+100	μA
Power Down and Mode Control Inputs (Single-Ended)						
	High Input Voltage ⁽²⁾		2.0		AV_{CC}	V
	Low Input Voltage ⁽²⁾		0		1.0	V
	Max Input Current Low ⁽¹⁾		-100	10	+100	μA
	Max Input Current High <4.0V ⁽¹⁾		-100	10	+100	μA
Digital Outputs						
	Logic "1" Voltage ⁽¹⁾	$I_{OH} = -0.5mA$	$OV_{DD}-2.0$	$OV_{DD}-0.06$		V
	Logic "0" Voltage ⁽¹⁾	$I_{OL} = +1.6mA$		0.13	0.2	V
	T_R/T_F Data	$OV_{DD} = 3V, 10pF$ load		3.5		ns
		$OV_{DD} = 5V, 10pF$ load		2.0		ns
	T_R/T_F DCLK	$OV_{DD} = 3V, 10pF$ load		1.3		ns
		$OV_{DD} = 5V, 10pF$ load		0.7		ns

Notes:

- 100% production tested at +25°C.
- Parameter is guaranteed (but not tested) by design and characterization data.

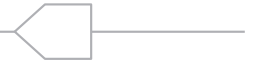

Typical Performance Characteristics

($T_A = T_{Min}$ to T_{Max} , $AV_{CC} = +5V$, $OV_{DD} = +5V$, $f_{clk} = 250MHz$, 50% duty cycle, $f_{IN} = 70MHz$, dual channel mode; unless otherwise noted)

AC Performance vs. Temperature

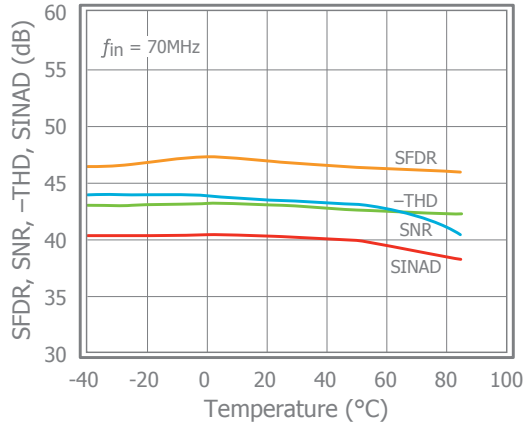

AC Performance vs. Temperature

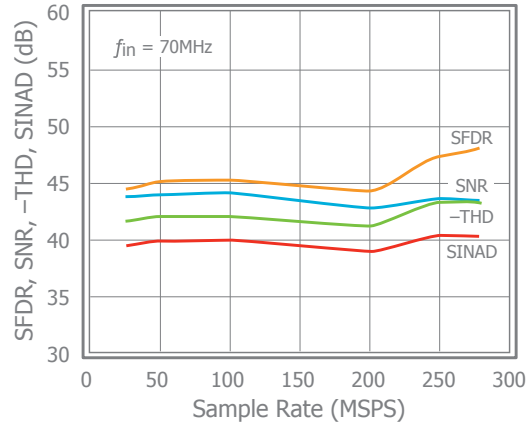

AV_{CC} Current vs. Temperature

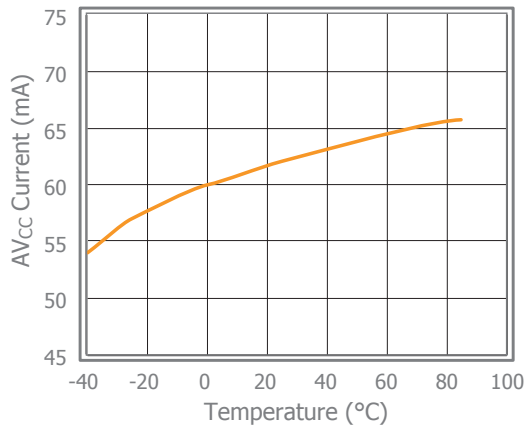

AV_{CC} Current Power Down vs. Temp.

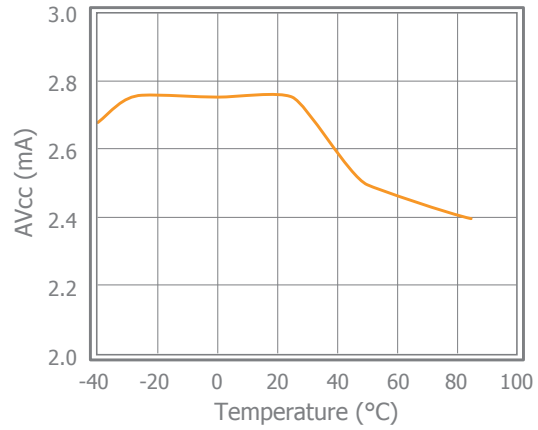

Voltage Offset Error vs. Temperature

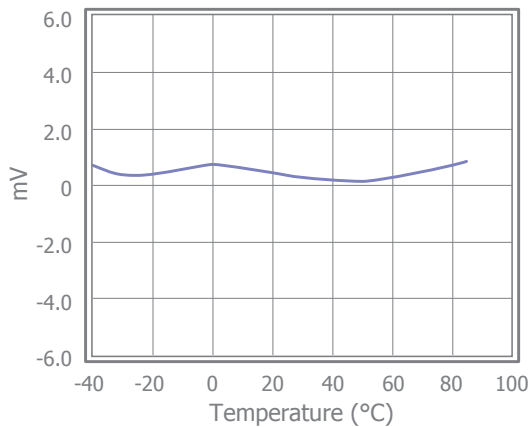

Percent Gain Error vs. Temperature

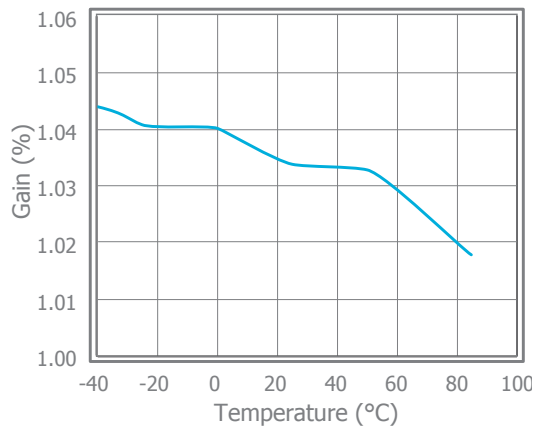

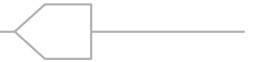

Typical Performance Characteristics

($T_A = T_{Min}$ to T_{Max} , $AV_{CC} = +5V$, $OV_{DD} = +5V$, $f_{clk} = 250MHz$, 50% duty cycle, $f_{IN} = 70MHz$, dual channel mode; unless otherwise noted)

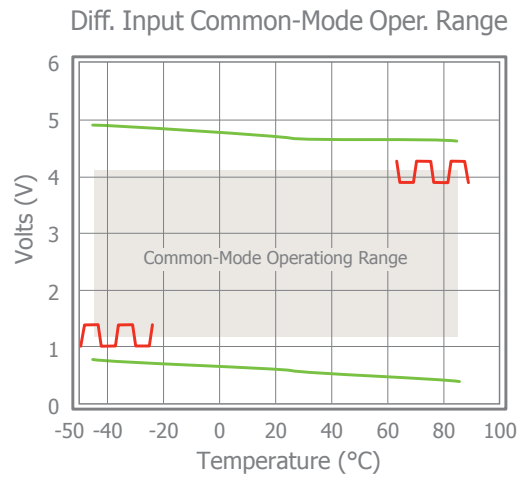
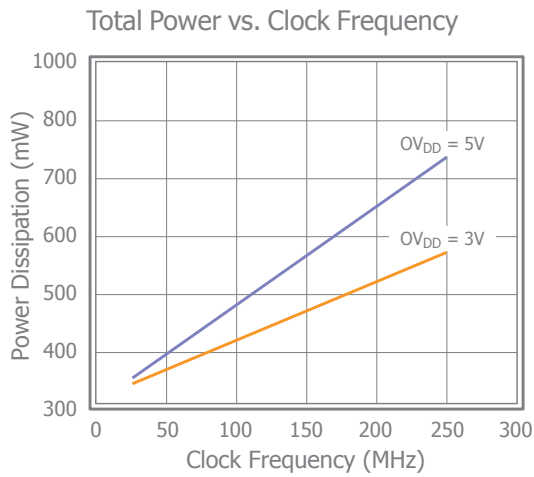
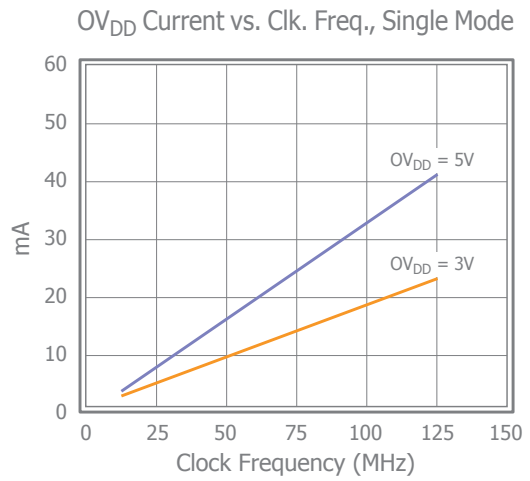
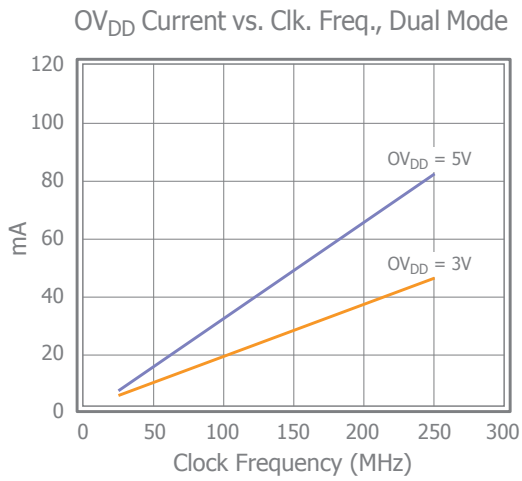
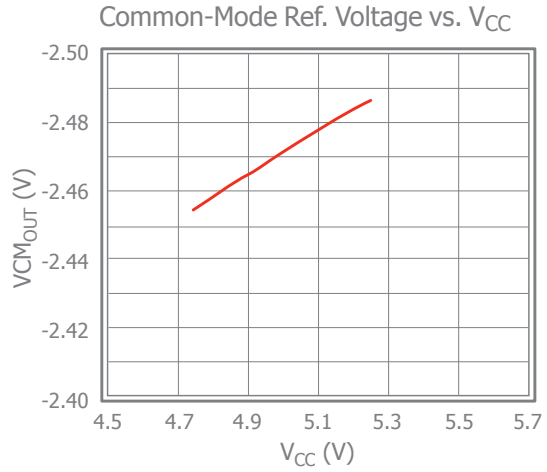
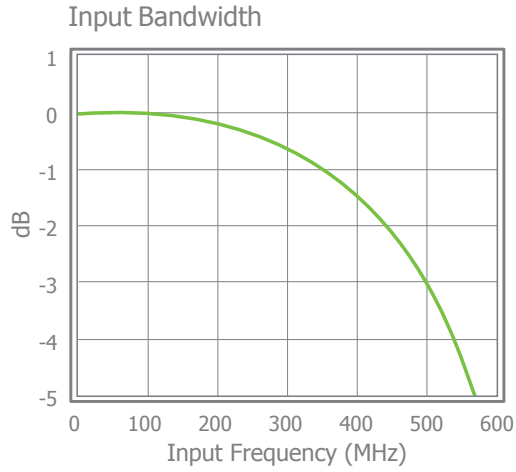

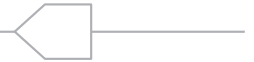

Theory of Operation

The CDK1300 is a three-step subranger. It consists of two THAs in series at the input, followed by three ADC blocks. The first block is a three-bit folder with over/under range detection. The second block consists of two single-bit folding interpolator stages. There are pipelining THAs between each ADC block.

The analog decode functions are the input buffer, input THAs, three-bit folder, folding interpolators, and pipelining THAs. The input buffer enables the part to withstand rail-to-rail input signals without latching or excessive currents and also performs single-ended to differential conversion. All of the THAs have the same basic architecture. Each has a differential pair buffer followed by switched emitter followers driving the hold capacitors. The input THA also has hold mode feedthrough cancellation devices.

The three MSBs of the ADC are generated in the first three-bit folder block, the output of which drives a differential reference ladder which also sets the full-scale input range. Differential pairs at the ladder taps generate midscale, quarter and three-quarter scale, overrange, and underrange. Every other differential pair collector is cross-coupled to generate the eighth scale zero crossings. The middle ADC block generates two bits from the folded signals of the previous stages after pipeline THAs. Its outputs drive more pipeline THAs to push the decoding of the three LSBs to the next half clock cycle. The three LSBs are generated in interpolators that are latched one full clock cycle after the MSBs.

The digital decode consists of comparators, exclusive of

cells for gray to binary decoding, and/or cells used for mostly over/under range logic. There is a total of 2.5 clock cycles latency before the output bank selection. In order to reduce sparkle codes and maintain sample rate, no more than three bits at a time are decoded in any half clock cycle.

The output data mode is controlled by the state of the demux mode inputs. There are three output modes:

- All data on bank A with clock rate limited to one-half maximum
- Interleaved mode with data alternately on banks A and B on alternate clock cycles
- Parallel mode with bank A delayed one cycle to be synchronous with bank B every other clock cycle

If necessary, the input clock is divided by two. The divided clock selects the correct output bank. The user can synchronize with the divided clock to select the desired output bank via the differential RESET input.

The output logic family is CMOS with output OVDD supply adjustable from 2.7V to 5.25V. There are also differential clock output pins that can be used to latch the output data in single bank mode or to indicate the current output bank in demux mode.

Finally, a power-down mode is available, which causes the outputs to become tri-state, and overall power is reduced to about 24mW. There is a 2V reference to supply common mode for single-ended inputs that is not shut down in powerdown mode.

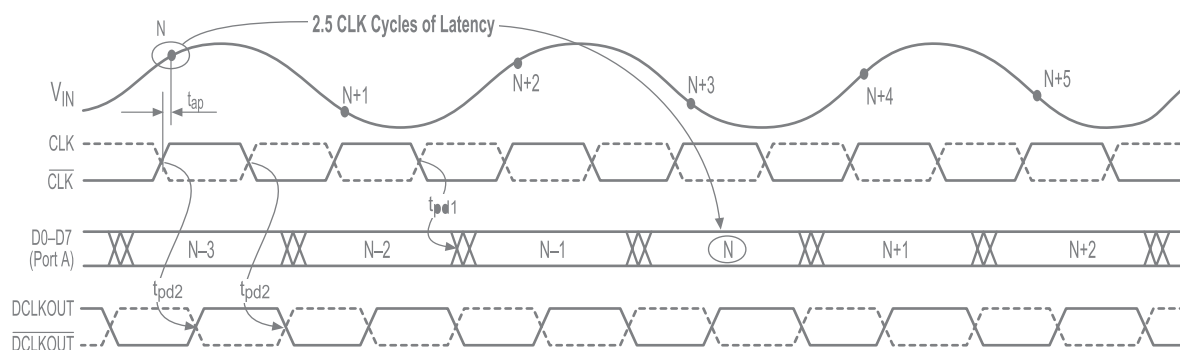

Figure 1. Single Mode Timing Diagram

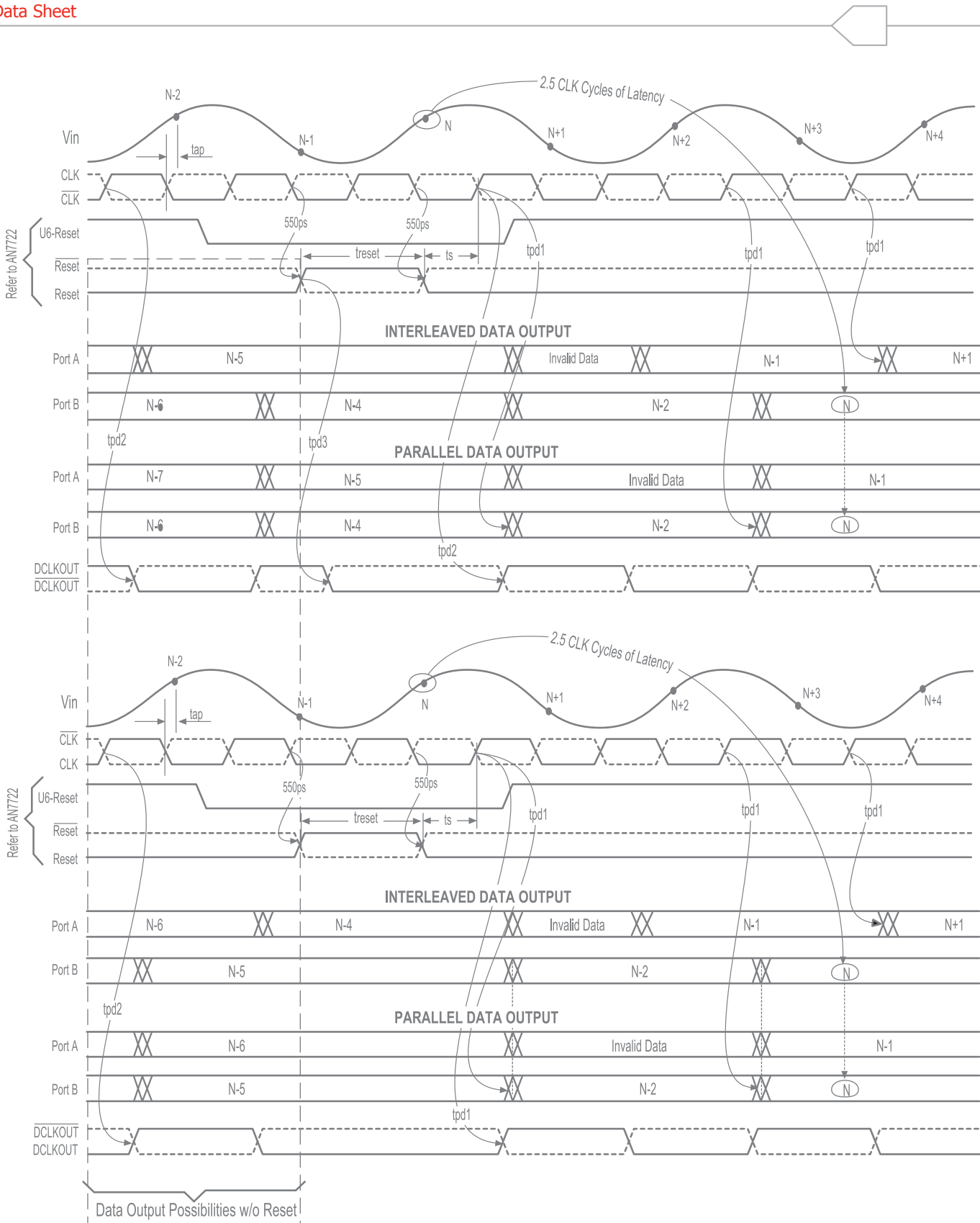

Figure 2. Dual Mode Timing Diagram

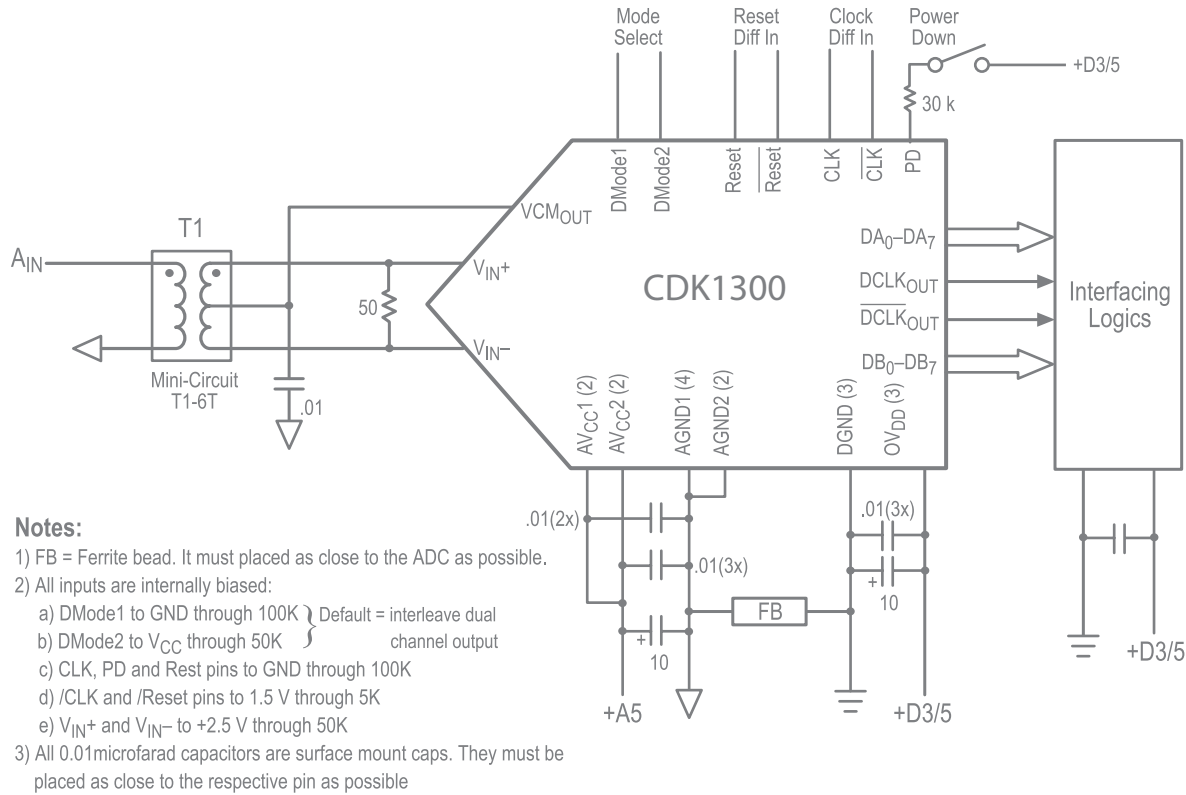

Figure 3. Typical Interface Circuit

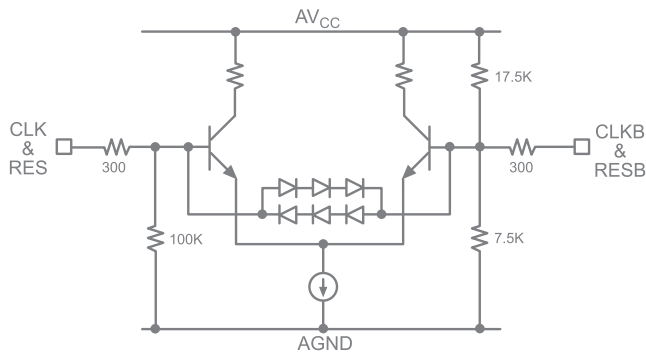

Figure 4. CLK and Reset Equivalent Circuit (without ESD Diodes)

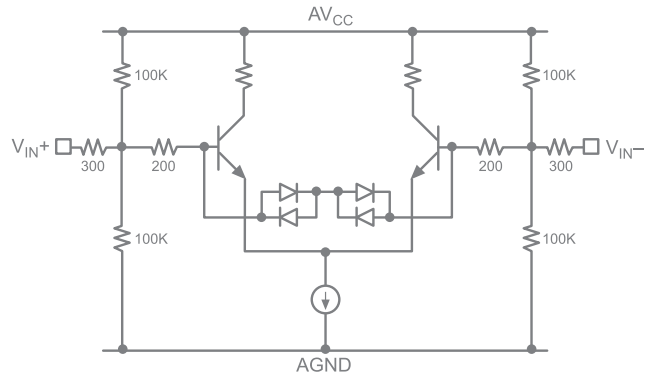

Figure 5. Analog Input Equivalent Circuit

Typical Interface Circuit

Very few external components are required to achieve the stated device performance. Figure 3 shows the typical interface requirements when using the CDK1300 in normal circuit operation. The following sections provide descriptions of the major functions and outline performance criteria to consider for achieving the optimal device performance.

Analog Input

The input of the CDK1300 can be configured in various ways depending on whether a single-ended or differential input is desired.

The AC-coupled input is most conveniently implemented using a transformer with a center-tapped secondary winding. The center tap is connected to the V_{CM} pin as shown in Figure 3. To obtain low distortion, it is important that the

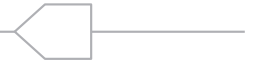

selected transformer does not exhibit core saturation at the full-scale voltage. Proper termination of the input is important for input signal purity. A small capacitor across the input attenuates kickback noise from the internal track-and-hold.

Figure 6 illustrates a solution (based on operational amplifiers) that can be used if a DC-coupled single-ended input is desired.

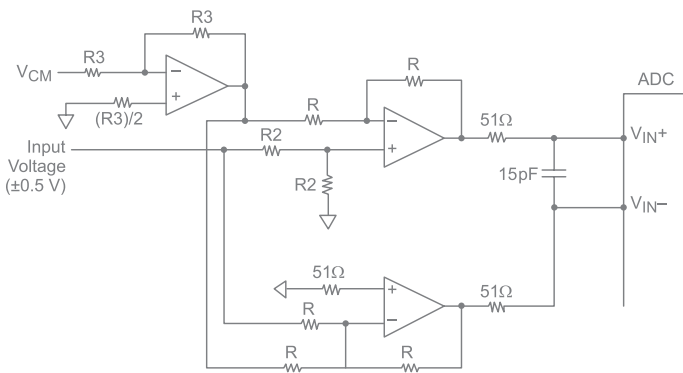

Figure 6. DC-Coupled Single-Ended to Differential Conversion (power supplies and bypassing are not shown)

Input Protection

All I/O pads are protected with an on-chip protection circuit. This circuit provides ESD robustness and prevents latchup under severe discharge conditions without degrading analog transmission times.

Power Supplies and Grounding

The CDK1300 is operated from a single power supply in the range of 4.75V to 5.25V. Normal operation is suggested to be 5.0V. All power supply pins should be bypassed as close to the package as possible. The analog and digital grounds should be connected together with a ferrite bead as shown in the typical interface circuit and as close to the ADC as possible.

Power-Down Mode

To save on power, the CDK1300 incorporates a power-down function. This function is controlled by the signal on pin PD. When pin PD is set high, the CDK1300 enters the power-down mode. All outputs are set to high impedance. In the powerdown mode the CDK1300 dissipates 24mW typically.

Common-Mode Voltage Reference Circuit

The CDK1300 has an on-board common-mode voltage reference circuit (V_{CM}). It is 2.5V and is capable of driving 50 μ A loads typically. The circuit is commonly used to drive the center tap of the RF transformer in fully differential applications. For single-ended applications, this output can be used to provide the level shifting required for the single-to-differential converter conversion circuit. Bypass V_{CM} to AGND by external 0.01 μ F capacitor, as shown in Figure 3 on the previous page.

Clock Input

The clock input on the CDK1300 can be driven by either a single-ended or double-ended clock circuit and can handle TTL, PECL, and CMOS signals. When operating at high sample rates it is important to keep the pulse width of the clock signal as close to 50% as possible. For TTL/CMOS single-ended clock inputs, the rise time of the signal also becomes an important consideration.

Digital Outputs

The output circuitry of the CDK1300 has been designed to be able to support three separate output modes. The demuxed (double-wide) mode supports either parallel aligned or interleaved data output. The single-channel mode is not demuxed and can support direct output at speeds up to 125 MSPS. The output format is straight binary (Table 1).

Table 1. Output Data Format

Analog Input	Output Code D7–D0
+FS	1111 1111
+FS - 1 LSB	1111 111 \emptyset
+1 FS	1000 000 \emptyset
-FS + 1 LSB	0000 000 \emptyset
-FS	0000 0000

\emptyset indicates the flickering bit between logic 0 and 1

The data output mode is set using the $DMODE_1$ and $DMODE_2$ inputs (pins 32 & 31 respectively). Table 2 describes the mode switching options.

Table 2. Output Data Modes

Output Mode	$DMODE_1$	$DMODE_2$
Parallel Dual Channel Output	0	0
Interleaved Dual Channel Output	0	1
Single Channel Data Output (Bank A only 125 MSPS max)	1	X

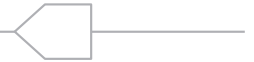

Evaluation Board

An evaluation board is available to aid designers in demonstrating the full performance of the CDK1300. This board includes a clock driver and reset circuit, adjustable references and common mode, a single-ended to differential input buffer and a single-ended to differential

transformer (1:1). An application note (TBD) describing the operation of this board, as well as information on the testing of the CDK1300, is also available. Contact the factory for price and availability.

Mechanical Dimensions

TQFP-44 Package

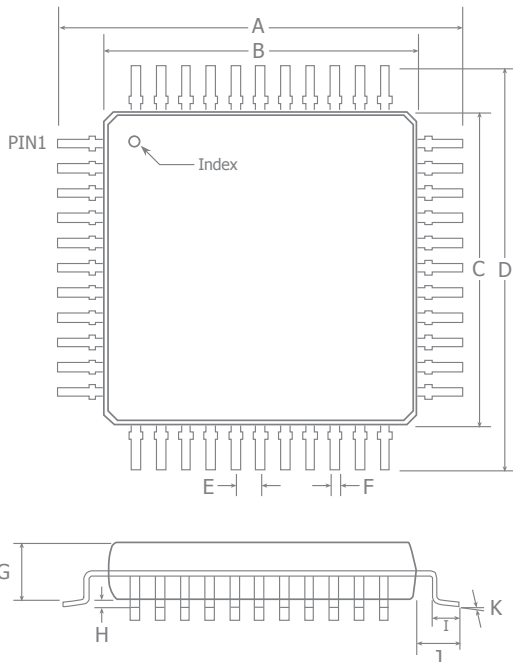

TQFP-44						
SYMBOL	INCHES			MILLIMETERS		
	MIN	TYP	MAX	MIN	TYP	MAX
A		0.472			12.00	
B		0.394			10.00	
C		0.394			10.00	
D		0.472			12.00	
E		0.031			0.80	
F	0.012		0.018	0.300		0.45
G	0.053		0.057	1.35		1.45
H	0.002		0.006	0.05		0.15
I	0.018		0.030	0.45		0.75
J		0.039			1.00	
K		0-7°			0-7°	

For Further Assistance:

Exar Corporation Headquarters and Sales Offices

48720 Kato Road
Fremont, CA 94538 - USA

Tel.: +1 (510) 668-7000
Fax: +1 (510) 668-7001
www.exar.com

NOTICE

EXAR Corporation reserves the right to make changes to the products contained in this publication in order to improve design, performance or reliability. EXAR Corporation assumes no responsibility for the use of any circuits described herein, conveys no license under any patent or other right, and makes no representation that the circuits are free of patent infringement. Charts and schedules contained here in are only for illustration purposes and may vary depending upon a user's specific application. While the information in this publication has been carefully checked; no responsibility, however, is assumed for inaccuracies.

EXAR Corporation does not recommend the use of any of its products in life support applications where the failure or malfunction of the product can reasonably be expected to cause failure of the life support system or to significantly affect its safety or effectiveness. Products are not authorized for use in such applications unless EXAR Corporation receives, in writing, assurances to its satisfaction that: (a) the risk of injury or damage has been minimized; (b) the user assumes all such risks; (c) potential liability of EXAR Corporation is adequately protected under the circumstances.

Reproduction, in part or whole, without the prior written consent of EXAR Corporation is prohibited.



A New Direction in Mixed-Signal