

Agilent HDSM-550G

13 mm 4-Digit and 7 Word Icons, Green, Clock Display Module

Data Sheet

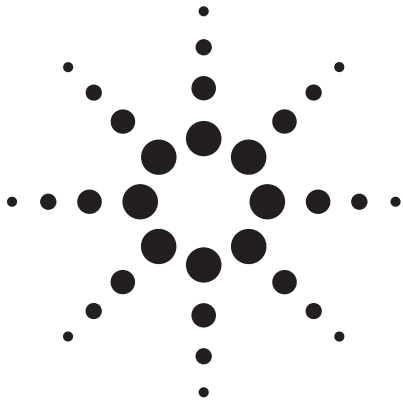

Features

- Color: green digit
- Gray face paint (gray package gives optimum contrast)
- Low power requirement

Applications

- As an indicator, e.g., temperature, etc.

Description

This display comprises four 13.00 mm seven-segment digits with seven word icons. It comes in gray face paint with green digits to give optimum contrast.

Absolute Maximum Ratings at $T_A = 25^\circ\text{C}$

| Parameter | Symbol | Rating | Units |
|--|-------------|-------------------|------------------|
| Power Dissipated per Segment | P_D | 65 | mW |
| Peak Forward Current per Segment (1/10 Duty Cycle, 0.1 ms Pulse Width) | I_{PEAK} | 100 | mA |
| DC Forward Current per Segment ^[1] | I_F | 25 ^[1] | mA |
| Reverse Voltage per Segment | V_R | 5 | V |
| Operating Temperature | T_O | -40 to +105 | $^\circ\text{C}$ |
| Storage Temperature | T_S | -40 to +105 | $^\circ\text{C}$ |
| Wavesoldering Conditions (2 mm Distance from the Body) | Temperature | 250 | $^\circ\text{C}$ |
| | Time | 3 | s |

Note:

1. Derate above 40°C at $0.33\text{ mA}/^\circ\text{C}$.

Electrical/Optical Characteristics at T_A = 25°C

| Parameter | Symbol | Min. | Typ. | Max. | Units | Test Conditions |
|---|---------------------|------|------|------|-----------|------------------------|
| Forward Voltage | V _F | | 2.25 | 2.50 | V | I _F = 20 mA |
| Reverse Current | I _R | | | 100 | μA | V _R = 5 V |
| Peak Emission Wavelength ^[1] | λ _{peak} | | 568 | | nm | I _F = 20 mA |
| Dominant Wavelength ^[1,3] | λ _D | | 573 | | nm | I _F = 20 mA |
| Spectral Halfwidth | Δλ _{1/2} | | 35 | | nm | I _F = 20 mA |
| Luminous Intensity ^[1,2] | I _V | 1125 | | 3520 | μcd | I _F = 10 mA |
| Thermal Resistance LED Junction-to-Pin | Rθ _{J-PIN} | | 480 | | °C/W/Seg. | |

Notes:

1. Case temperature of the device immediately prior to the intensity measurement is 25°C.
2. The digits are categorized for luminous intensity. The intensity category is designated by a letter on the side of the package.
3. The dominant wavelength, λ_D, is derived from the CIE Chromaticity Diagram and represents the single wavelength which defines the color of the device.

Package Dimensions

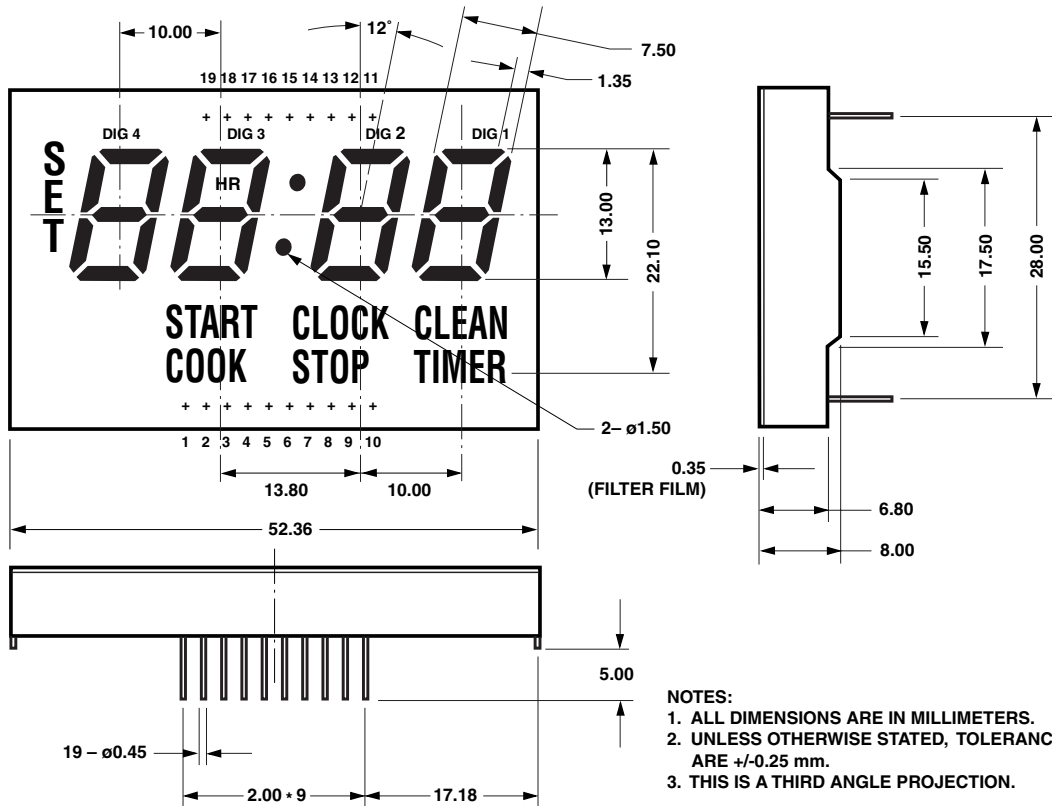

- NOTES:**
1. ALL DIMENSIONS ARE IN MILLIMETERS.
 2. UNLESS OTHERWISE STATED, TOLERANCES ARE +/-0.25 mm.
 3. THIS IS A THIRD ANGLE PROJECTION.

Circuit Diagram and Pin Connection

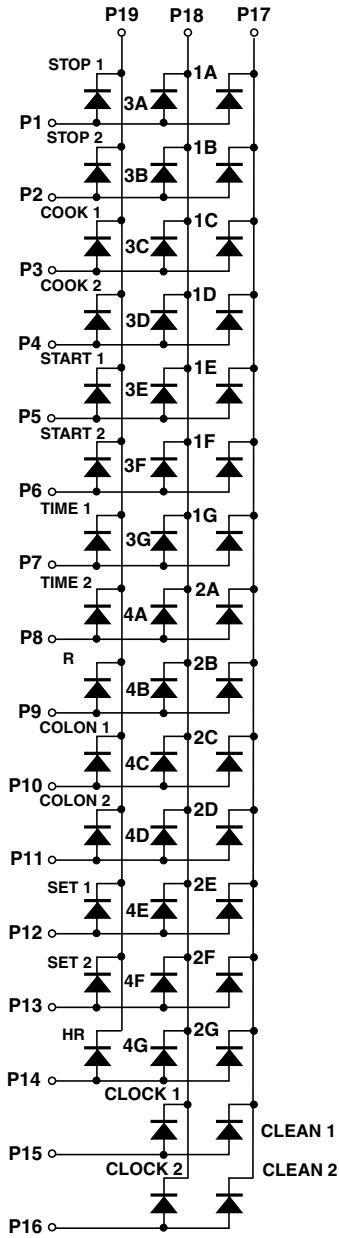

| PIN | PIN 19 | PIN 18 | PIN 17 |
|--------|--------|--------|--------|
| PIN 1 | STOP1 | 3A | 1A |
| PIN 2 | STOP2 | 3B | 1B |
| PIN 3 | COOK1 | 3C | 1C |
| PIN 4 | COOK2 | 3D | 1D |
| PIN 5 | START1 | 3E | 1E |
| PIN 6 | START2 | 3F | 1F |
| PIN 7 | TIME1 | 3G | 1G |
| PIN 8 | TIME2 | 4A | 2A |
| PIN 9 | R | 4B | 2B |
| PIN 10 | COLON1 | 4C | 2C |
| PIN 11 | COLON2 | 4D | 2D |
| PIN 12 | SET1 | 4E | 2E |
| PIN 13 | SET2 | 4F | 2F |
| PIN 14 | HR | 4G | 2G |
| PIN 15 | - | CLOCK1 | CLEAN1 |
| PIN 16 | - | CLOCK2 | CLEAN2 |

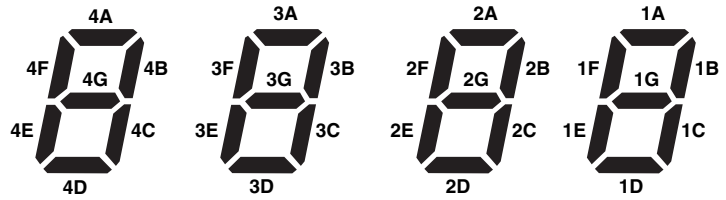

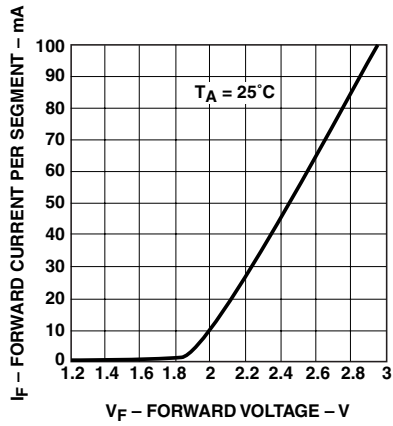

Figure 1. Forward current vs. forward voltage.

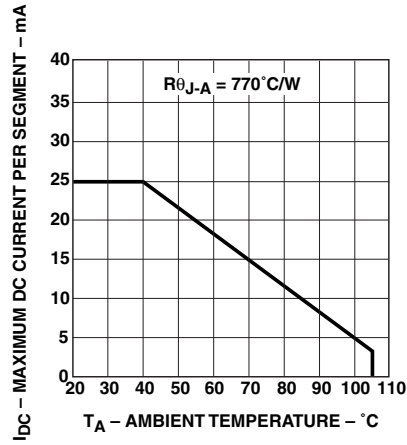

Figure 2. Maximum allowable DC current vs. ambient temperature.

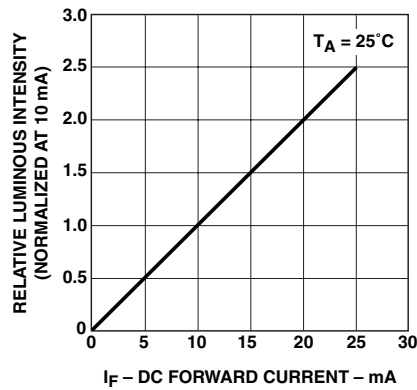

Figure 3. Relative luminous intensity vs. DC forward current.

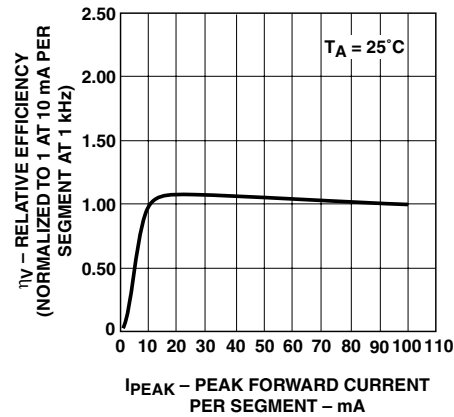

Figure 4. Relative efficiency (luminous intensity per unit current) vs. peak current.

www.agilent.com/semiconductors

For product information and a complete list of distributors, please go to our web site.

For technical assistance call:

Americas/Canada: +1 (800) 235-0312 or (916) 788-6763

Europe: +49 (0) 6441 92460

China: 10800 650 0017

Hong Kong: (+65) 6756 2394

India, Australia, New Zealand: (+65) 6755 1939

Japan: (+81 3) 3335-8152 (Domestic/International), or 0120-61-1280 (Domestic Only)

Korea: (+65) 6755 1989

Singapore, Malaysia, Vietnam, Thailand, Philippines, Indonesia: (+65) 6755 2044

Taiwan: (+65) 6755 1843

Data subject to change.

Copyright © 2004 Agilent Technologies, Inc.

June 24, 2004

5988-1573EN

Intensity of Green Bin Limits (mcd at 10 mA)

| Bin ID | Min. | Max. |
|--------|------|------|
| I | 1.25 | 2.00 |
| K | 2.00 | 3.20 |

Tolerance for each bin limit is $\pm 10\%$.

Green Color Bin Limits (mcd at 20 mA)

| Bin ID | Min. | Max. |
|--------|-------|-------|
| 2 | 573.5 | 576.5 |
| 3 | 570.5 | 573.5 |

Tolerance for each bin limit is ± 0.5 nm.

Contrast Enhancement

For information on contrast enhancement please see Application Note 1015.

Soldering/Cleaning

Cleaning agents from the ketone family (acetone, methyl ethyl ketone, etc.) and from the chlorinated hydrocarbon family (methylene chloride, trichloroethylene, carbon tetrachloride, etc.) are not recommended for cleaning LED parts. All of these various solvents attack or dissolve the encapsulating epoxies used to form the package of plastic LED parts.

For information on soldering LEDs please refer to Application Note 1027.