

Dual - MOSMIC[®]- two AGC Amplifiers for TV-Tuner Prestage with Integrated Band Switch for One-Line Switching

Comments

MOSMIC - MOS Monolithic Integrated Circuit

Description

The Dual-MOSMIC[®] TSDF12830YS, assembled in the well-known SOT-363 plastic package, is a combination of two different MOSMIC[®] amplifiers with common Source and common Gate 2 leads and an integrated switch. One of the MOSMIC stages is optimized for use in VHF applications, especially regarding cross modulation performance and noise figure at lower VHF frequencies, whereas the other stage is optimized for use in UHF applications regarding gain and noise figure performance at higher frequencies of UHF range. The integrated switch is operated by the Gate 1 bias of the UHF amplifier on Pin 6. All of the Gates are protected against excessive input voltage surges by integrated antiseri- diodes between themselves and Source.

Features

- Two differently optimized amplifiers in a single package. One of them has a fully internal self-biasing network on chip and the other has a partly integrated bias for easy Gate 1 switch-off with PNP switching transistors inside PLL -IC
- Internal switch for saving lines on PCB layout as well as external components
- Integrated gate protection diodes
- Low noise figure, high gain
- Typical forward transadmittance of 31 mS resp. 28 mS
- Superior cross modulation at gain reduction
- High AGC-range with soft slope
- Main AGC control range from 3 V to 0.5 V
- Lead (Pb)-free component
- Component in accordance to RoHS 2002/95/EC and WEEE 2002/96/EC

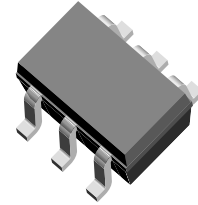
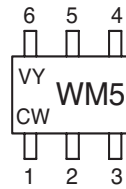

18597



Electrostatic sensitive device.
Observe precautions for handling

Applications

Low noise gain controlled VHF and UHF input stages with 5 V supply voltage, such as in digital and analog TV tuners and in other multimedia and communications equipment.

Typical Application

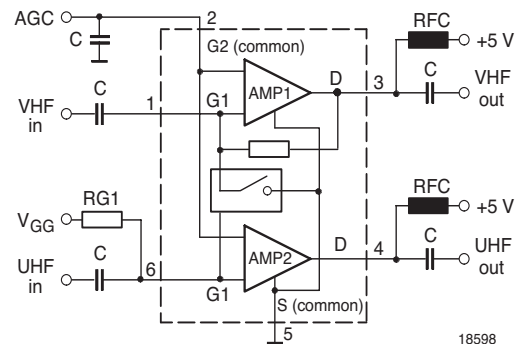

$V_{GG} = 5\text{ V}$: UHF AMP is on; VHF AMP is off
 $V_{GG} = 0\text{ V}$: UHF AMP is off; VHF AMP is on
 (0 = shorted to Ground or open)

18598

Mechanical Data

Case: SOT-363 Plastic case

Weight: approx. 6.0 mg

Parts Table

Part	Marking	Package
TSDF12830YS	WM5	SOT-363

Absolute Maximum Ratings

$T_{amb} = 25\text{ }^{\circ}\text{C}$, unless otherwise specified

Amplifier 1

Following data are valid for operating amplifier 1 (pin 1, 3, 2, 5) which is optimized for VHF applications

Parameter	Test condition	Symbol	Value	Unit
Drain - source voltage		V_{DS}	8	V
Drain current		I_D	30	mA
Gate 1/Gate 2 - source peak current		$\pm I_{G1/G2SM}$	10	mA
Gate 1/Gate 2 - source voltage		$+V_{G1} \pm V_{G2SM}$	6	V
Gate 1 - source voltage		$-V_{G1SM}$	1.5	V
Total power dissipation	$T_{amb} \leq 60\text{ }^{\circ}\text{C}$	P_{tot}	200	mW
Channel temperature		T_{Ch}	150	$^{\circ}\text{C}$
Storage temperature range		T_{stg}	- 55 to + 150	$^{\circ}\text{C}$

Amplifier 2

Following data are valid for operating amplifier 2 (pin 6, 4, 2, 5) which is optimized for UHF applications

Parameter	Test condition	Symbol	Value	Unit
Drain - source voltage		V_{DS}	8	V
Drain current		I_D	25	mA
Gate 1/Gate 2 - source peak current		$\pm I_{G1/G2SM}$	10	mA
Gate 1/Gate 2 - source voltage		$+V_{G1} \pm V_{G2SM}$	6	V
Gate 1 - source voltage		$-V_{G1SM}$	1.5	V
Total power dissipation	$T_{amb} \leq 60\text{ }^{\circ}\text{C}$	P_{tot}	200	mW
Channel temperature		T_{Ch}	150	$^{\circ}\text{C}$
Storage temperature range		T_{stg}	- 55 to + 150	$^{\circ}\text{C}$

Maximum Thermal Resistance

Parameter	Test condition	Symbol	Value	Unit
Channel ambient	1)	R_{thChA}	450	K/W

1) on glass fibre printed board (25 x 20 x 1.5) mm³ plated with 35 μm Cu

Electrical DC Characteristics

$T_{amb} = 25\text{ }^{\circ}\text{C}$, unless otherwise specified

Amplifier 1

Following data are valid for operating amplifier 1 (pin 1, 3, 2, 5) which is optimized for VHF applications

Parameter	Test condition	Symbol	Min	Typ.	Max	Unit
Gate 1 - source breakdown voltage	$+ I_{G1S} = 10\text{ mA}, V_{G2S} = V_{DS} = 0$	$+ V_{(BR)G1SS}$	7		10	V
Gate 2 - source breakdown voltage	$\pm I_{G2S} = 10\text{ mA}, V_{G1S} = V_{DS} = 0$	$\pm V_{(BR)G2SS}$	7		10	V
Gate 1 - source leakage current	$+ V_{G1S} = 5\text{ V}, V_{G2S} = V_{DS} = 0$	$+ I_{G1SS}$			50	μA
Gate 2 - source leakage current	$\pm V_{G2S} = 5\text{ V}, V_{G1S} = V_{DS} = 0$	$\pm I_{G2SS}$			20	nA
Drain - source operating current	$V_{DS} = V_{RG1} = 5\text{ V}, V_{G2S} = 4\text{ V},$ Gate 1 = nc	I_{DSP}	8	13	17	mA
Gate 2 - source cut-off voltage	$V_{DS} = V_{RG1} = 5\text{ V},$ Gate 1 = nc, $I_D = 20\text{ }\mu\text{A}$	$V_{G2S(OFF)}$	0.3		1.2	V

Amplifier 2

Following data are valid for operating amplifier 2 (pin 6, 4, 2, 5) which is optimized for UHF applications

Parameter	Test condition	Symbol	Min	Typ.	Max	Unit
Drain - source breakdown voltage	$I_D = 10\text{ }\mu\text{A}, V_{G2S} = V_{G1S} = 0$	$V_{(BR)DSS}$	15			V
Gate 1 - source breakdown voltage	$+ I_{G1S} = 10\text{ mA}, V_{G2S} = V_{DS} = 0$	$+ V_{(BR)G1SS}$	7		10	V
	$\pm I_{G2S} = 10\text{ mA}, V_{G1S} = V_{DS} = 0$	$\pm V_{(BR)G2SS}$	7		10	V
Gate 1 - source leakage current	$+ V_{G1S} = 5\text{ V}, V_{G2S} = V_{DS} = 0$	$+ I_{G1SS}$			20	nA
Gate 2 - source leakage current	$\pm V_{G2S} = 5\text{ V}, V_{G1S} = V_{DS} = 0$	$\pm I_{G2SS}$			20	nA
Drain - source operating current	$V_{DS} = V_{RG1} = 5\text{ V}, V_{G2S} = 4\text{ V},$ $R_{G1} = 100\text{ k}\Omega$	I_{DSO}	8	12	17	mA
Gate 1 - source cut-off voltage	$V_{DS} = 5\text{ V}, V_{G2S} = 4\text{ V}, I_D = 20\text{ }\mu\text{A}$	$V_{G1S(OFF)}$	0.3		1.0	V
Gate 2 - source cut-off voltage	$V_{DS} = V_{RG1} = 5\text{ V}, R_{G1} = 100\text{ k}\Omega,$ $I_D = 20\text{ }\mu\text{A}$	$V_{G2S(OFF)}$	0.3		1.2	V

Electrical AC Characteristics

$T_{amb} = 25\text{ }^{\circ}\text{C}$, unless otherwise specified

Amplifier 1

$V_{DS} = V_{RG1} = 5\text{ V}$, $V_{G2S} = 4\text{ V}$, Gate 1 = nc, $I_D = I_{DSP}$, $f = 1\text{ MHz}$, $T_{amb} = 25\text{ }^{\circ}\text{C}$, unless otherwise specified

Following data are valid for operating amplifier 1 (pin 1, 3, 2, 5) which is optimized for VHF applications

Parameter	Test condition	Symbol	Min	Typ.	Max	Unit
Forward transadmittance		$ y_{21s} $	23	28	33	mS
Gate 1 input capacitance		C_{issg1}		2.2	2.7	pF
Feedback capacitance		C_{rss}		20		fF
Output capacitance		C_{oss}		1.0		pF
Power gain	$G_S = 2\text{ mS}$, $B_S = B_{Sopt}$, $G_L = 0.5\text{ mS}$, $B_L = B_{Lopt}$, $f = 200\text{ MHz}$	G_{ps}		32		dB
	$G_S = 2\text{ mS}$, $B_S = B_{Sopt}$, $G_L = 1\text{ mS}$, $B_L = B_{Lopt}$, $f = 400\text{ MHz}$	G_{ps}		28		dB
	$G_S = 3.3\text{ mS}$, $B_S = B_{Sopt}$, $G_L = 1\text{ mS}$, $B_L = B_{Lopt}$, $f = 800\text{ MHz}$	G_{ps}		22		dB
AGC range	$V_{DS} = 5\text{ V}$, $V_{G2S} = 0.5\text{ to }4\text{ V}$, $f = 200\text{ MHz}$	G_{ps}		50		dB
Noise figure	$G_S = G_L = 20\text{ mS}$, $B_S = B_L = 0$, $f = 50\text{ MHz}$	F		4.5	6.0	dB
	$G_S = 2\text{ mS}$, $G_L = 1\text{ mS}$, $B_S = B_{Sopt}$, $f = 400\text{ MHz}$	F		1.0	1.6	dB
	$G_S = 3.3\text{ mS}$, $G_L = 1\text{ mS}$, $B_S = B_{Sopt}$, $f = 800\text{ MHz}$	F		1.5	2.3	dB
Cross modulation	Input level for $k = 1\%$ @ 0 dB AGC $f_w = 50\text{ MHz}$, $f_{unw} = 60\text{ MHz}$	X_{mod}	90			dB μ V
	Input level for $k = 1\%$ @ 40 dB AGC $f_w = 50\text{ MHz}$, $f_{unw} = 60\text{ MHz}$	X_{mod}	105			dB μ V

Remark on improving intermodulation behavior:

By setting R_{G1} smaller than $56\text{ k}\Omega$, typical value of I_{DSO} will raise and improved intermodulation behavior will be performed.

Amplifier 2

$V_{DS} = V_{RG1} = 5\text{ V}$, $V_{G2S} = 4\text{ V}$, $R_{G1} = 100\text{ k}\Omega$, $I_D = I_{DSO}$, $f = 1\text{ MHz}$, $T_{amb} = 25\text{ }^\circ\text{C}$, unless otherwise specified
 Following data are valid for operating amplifier 2 (pin 6, 4, 2, 5) which is optimized for UHF applications

Parameter	Test condition	Symbol	Min	Typ.	Max	Unit
Forward transadmittance		$ Y_{21s} $	27	31	35	mS
Gate 1 input capacitance		C_{issg1}		1.7	2.1	pF
Feedback capacitance		C_{rss}		20		fF
Output capacitance		C_{oss}		0.9		pF
Power gain	$G_S = 2\text{ mS}$, $B_S = B_{Sopt}$, $G_L = 0.5\text{ mS}$, $B_L = B_{Lopt}$, $f = 200\text{ MHz}$	G_{ps}		33		dB
	$G_S = 3.3\text{ mS}$, $B_S = B_{Sopt}$, $G_L = 1\text{ mS}$, $B_L = B_{Lopt}$, $f = 400\text{ MHz}$	G_{ps}		30		dB
	$G_S = 3.3\text{ mS}$, $B_S = B_{Sopt}$, $G_L = 1\text{ mS}$, $B_L = B_{Lopt}$, $f = 800\text{ MHz}$	G_{ps}		25		dB
AGC range	$V_{DS} = 5\text{ V}$, $V_{G2S} = 0.5\text{ to }4\text{ V}$, $f = 800\text{ MHz}$	G_{ps}	40	50		dB
Noise figure	$G_S = G_L = 20\text{ mS}$, $B_S = B_L = 0$, $f = 50\text{ MHz}$	F		5.0	7.0	dB
	$G_S = 2\text{ mS}$, $G_L = 0.5\text{ mS}$, $B_S = B_{Sopt}$, $f = 400\text{ MHz}$	F		1.0	1.5	dB
	$G_S = 3.3\text{ mS}$, $G_L = 1\text{ mS}$, $B_S = B_{Sopt}$, $f = 800\text{ MHz}$	F		1.3	2.0	dB
Cross modulation	Input level for $k = 1\% @ 0\text{ dB}$ AGC $f_w = 50\text{ MHz}$, $f_{unw} = 60\text{ MHz}$	X_{mod}	90			dB μ V
	Input level for $k = 1\% @ 40\text{ dB}$ AGC $f_w = 50\text{ MHz}$, $f_{unw} = 60\text{ MHz}$	X_{mod}	100	105		dB μ V

Remark on improving intermodulation behavior:

By setting R_{G1} smaller than $100\text{ k}\Omega$, typical value of I_{DSO} will raise and improved intermodulation behavior will be performed.

Package Dimensions in mm (Inches)

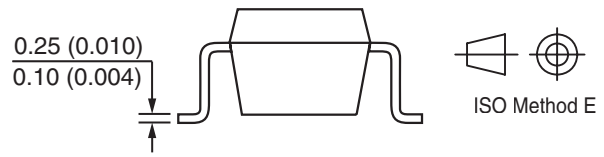
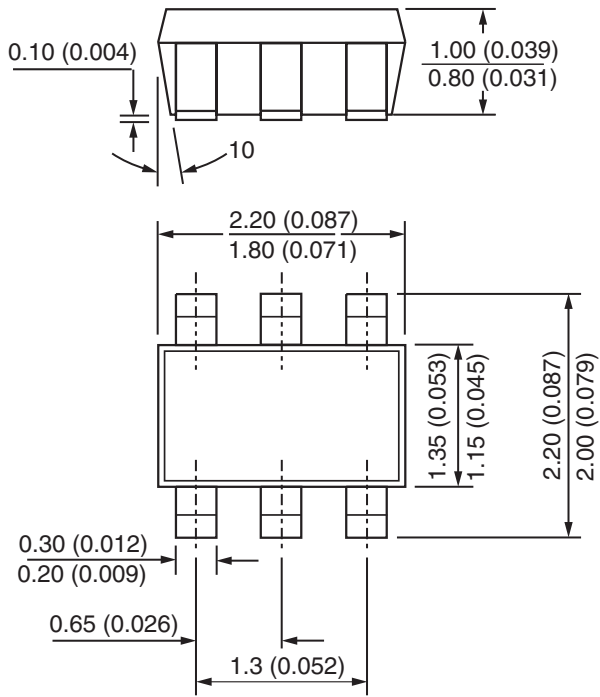

Mounting Pad Layout

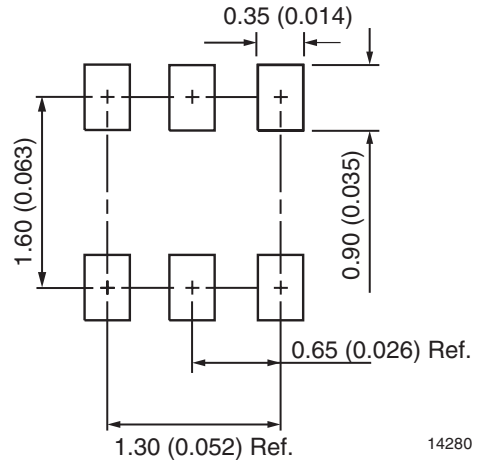

14280



Ozone Depleting Substances Policy Statement

It is the policy of Vishay Semiconductor GmbH to

1. Meet all present and future national and international statutory requirements.
2. Regularly and continuously improve the performance of our products, processes, distribution and operating systems with respect to their impact on the health and safety of our employees and the public, as well as their impact on the environment.

It is particular concern to control or eliminate releases of those substances into the atmosphere which are known as ozone depleting substances (ODSs).

The Montreal Protocol (1987) and its London Amendments (1990) intend to severely restrict the use of ODSs and forbid their use within the next ten years. Various national and international initiatives are pressing for an earlier ban on these substances.

Vishay Semiconductor GmbH has been able to use its policy of continuous improvements to eliminate the use of ODSs listed in the following documents.

1. Annex A, B and list of transitional substances of the Montreal Protocol and the London Amendments respectively
2. Class I and II ozone depleting substances in the Clean Air Act Amendments of 1990 by the Environmental Protection Agency (EPA) in the USA
3. Council Decision 88/540/EEC and 91/690/EEC Annex A, B and C (transitional substances) respectively.

Vishay Semiconductor GmbH can certify that our semiconductors are not manufactured with ozone depleting substances and do not contain such substances.

We reserve the right to make changes to improve technical design and may do so without further notice.

Parameters can vary in different applications. All operating parameters must be validated for each customer application by the customer. Should the buyer use Vishay Semiconductors products for any unintended or unauthorized application, the buyer shall indemnify Vishay Semiconductors against all claims, costs, damages, and expenses, arising out of, directly or indirectly, any claim of personal damage, injury or death associated with such unintended or unauthorized use.

Vishay Semiconductor GmbH, P.O.B. 3535, D-74025 Heilbronn, Germany



Notice

Specifications of the products displayed herein are subject to change without notice. Vishay Intertechnology, Inc., or anyone on its behalf, assumes no responsibility or liability for any errors or inaccuracies.

Information contained herein is intended to provide a product description only. No license, express or implied, by estoppel or otherwise, to any intellectual property rights is granted by this document. Except as provided in Vishay's terms and conditions of sale for such products, Vishay assumes no liability whatsoever, and disclaims any express or implied warranty, relating to sale and/or use of Vishay products including liability or warranties relating to fitness for a particular purpose, merchantability, or infringement of any patent, copyright, or other intellectual property right.

The products shown herein are not designed for use in medical, life-saving, or life-sustaining applications. Customers using or selling these products for use in such applications do so at their own risk and agree to fully indemnify Vishay for any damages resulting from such improper use or sale.