

TSB12LV23A

**OHCI-Lynx™ PCI-Based IEEE 1394 Host
Controller**

Data Manual

NOTE

Designing with this device may require extensive support. Before incorporating this device into a design, customers should contact TI or an Authorized TI Distributor.

IMPORTANT NOTICE

Texas Instruments and its subsidiaries (TI) reserve the right to make changes to their products or to discontinue any product or service without notice, and advise customers to obtain the latest version of relevant information to verify, before placing orders, that information being relied on is current and complete. All products are sold subject to the terms and conditions of sale supplied at the time of order acknowledgment, including those pertaining to warranty, patent infringement, and limitation of liability.

TI warrants performance of its semiconductor products to the specifications applicable at the time of sale in accordance with TI's standard warranty. Testing and other quality control techniques are utilized to the extent TI deems necessary to support this warranty. Specific testing of all parameters of each device is not necessarily performed, except those mandated by government requirements.

Customers are responsible for their applications using TI components.

In order to minimize risks associated with the customer's applications, adequate design and operating safeguards must be provided by the customer to minimize inherent or procedural hazards.

TI assumes no liability for applications assistance or customer product design. TI does not warrant or represent that any license, either express or implied, is granted under any patent right, copyright, mask work right, or other intellectual property right of TI covering or relating to any combination, machine, or process in which such semiconductor products or services might be or are used. TI's publication of information regarding any third party's products or services does not constitute TI's approval, warranty or endorsement thereof.

Contents

<i>Section</i>	<i>Title</i>	<i>Page</i>
1	Introduction	1-1
1.1	Description	1-1
1.2	Features	1-1
1.3	Related Documents	1-2
1.4	Trademarks	1-2
1.5	Ordering Information	1-2
2	Terminal Descriptions	2-1
3	TSB12LV23A Controller Programming Model	3-1
3.1	PCI/CardBus Configuration Registers	3-3
3.2	Vendor ID Register	3-3
3.3	Device ID Register	3-4
3.4	Command Register	3-4
3.5	Status Register	3-5
3.6	Class Code and Revision ID Register	3-6
3.7	Latency Timer and Class Cache Line Size Register	3-6
3.8	Header Type and BIST Register	3-7
3.9	OHCI Base Address Register	3-7
3.10	TI Extension Base Address Register	3-8
3.11	CIS Base Address Register	3-8
3.12	CardBus CIS Pointer Register	3-9
3.13	Subsystem Identification Register	3-10
3.14	Power Management Capabilities Pointer Register	3-10
3.15	Interrupt Line and Pin Register	3-11
3.16	MIN_GNT and MAX_LAT Register	3-11
3.17	OHCI Control Register	3-12
3.18	Capability ID and Next Item Pointer Register	3-12
3.19	Power Management Capabilities Register	3-13
3.20	Power Management Control and Status Register	3-14
3.21	Power Management Extension Register	3-14
3.22	Miscellaneous Configuration Register	3-15
3.23	Link Enhancement Control Register	3-16
3.24	Subsystem Access Register	3-17
3.25	GPIO Control Register	3-18
4	OHCI Registers	4-1
4.1	OHCI Version Register	4-4
4.2	GUID ROM Register	4-5
4.3	Asynchronous Transmit Retries Register	4-6

4.4	CSR Data Register	4-6
4.5	CSR Compare Register	4-7
4.6	CSR Control Register	4-7
4.7	Configuration ROM Header Register	4-8
4.8	Bus Identification Register	4-8
4.9	Bus Options Register	4-9
4.10	GUID High Register	4-10
4.11	GUID Low Register	4-10
4.12	Configuration ROM Mapping Register	4-11
4.13	Posted Write Address Low Register	4-11
4.14	Posted Write Address High Register	4-12
4.15	Vendor ID Register	4-12
4.16	Host Controller Control Register	4-13
4.17	Self-ID Buffer Pointer Register	4-14
4.18	Self-ID Count Register	4-15
4.19	Isochronous Receive Channel Mask High Register	4-16
4.20	Isochronous Receive Channel Mask Low Register	4-17
4.21	Interrupt Event Register	4-18
4.22	Interrupt Mask Register	4-20
4.23	Isochronous Transmit Interrupt Event Register	4-21
4.24	Isochronous Transmit Interrupt Mask Register	4-22
4.25	Isochronous Receive Interrupt Event Register	4-22
4.26	Isochronous Receive Interrupt Mask Register	4-23
4.27	Fairness Control Register	4-23
4.28	Link Control Register	4-24
4.29	Node Identification Register	4-25
4.30	PHY Layer Control Register	4-26
4.31	Isochronous Cycle Timer Register	4-27
4.32	Asynchronous Request Filter High Register	4-28
4.33	Asynchronous Request Filter Low Register	4-30
4.34	Physical Request Filter High Register	4-31
4.35	Physical Request Filter Low Register	4-33
4.36	Physical Upper Bound Register (Optional Register)	4-33
4.37	Asynchronous Context Control Register	4-34
4.38	Asynchronous Context Command Pointer Register	4-35
4.39	Isochronous Transmit Context Control Register	4-36
4.40	Isochronous Transmit Context Command Pointer Register	4-37
4.41	Isochronous Receive Context Control Register	4-37
4.42	Isochronous Receive Context Command Pointer Register	4-39
4.43	Isochronous Receive Context Match Register	4-40
4.44	IR Digital Video Enhancements Register	4-41
5	GPIO Interface	5-1
6	Serial ROM Interface	6-1
7	Electrical Characteristics	7-1

7.1	Absolute Maximum Ratings Over Operating Temperature Ranges	7-1
7.2	Recommended Operating Conditions	7-2
7.3	Electrical Characteristics Over Recommended Operating Conditions	7-3
7.4	Switching Characteristics for PCI Interface	7-3
7.5	Switching Characteristics for PHY-Link Interface	7-3
8	Mechanical Information	8-1

List of Illustrations

<i>Figure</i>	<i>Title</i>	<i>Page</i>
2-1	Terminal Assignments	2-1
3-1	TSB12LV23A Block Diagram	3-2
5-1	GPIO2 and GPIO3 Logic Diagram	5-1

List of Tables

<i>Table</i>	<i>Title</i>	<i>Page</i>
2-1	Signals Sorted by Terminal Number	2-2
2-2	Signals Sorted Alphabetically to Terminal Number	2-3
2-3	Power Supply Terminals	2-3
2-4	PCI System Terminals	2-4
2-5	PCI Address and Data Terminals	2-4
2-6	PCI Interface Control Terminals	2-5
2-7	IEEE 1394 PHY/Link Terminals	2-6
2-8	Miscellaneous Terminals	2-6
3-1	Bit Field Access Tag Descriptions	3-1
3-2	PCI Configuration Register Map	3-3
3-3	Command Register Description	3-4
3-4	Status Register Description	3-5
3-5	Class Code and Revision ID Register Description	3-6
3-6	Latency Timer and Class Cache Line Size Register Description	3-6
3-7	Header Type and BIST Register Description	3-7
3-8	OHCI Base Address Register Description	3-7
3-9	CIS Base Address Register Description	3-8
3-10	CardBus CIS Pointer Register Description	3-9
3-11	Subsystem Identification Register Description	3-10
3-12	Interrupt Line and Pin Register Description	3-11
3-13	MIN_GNT and MAX_LAT Register Description	3-11
3-14	OHCI Control Register Description	3-12
3-15	Capability ID and Next Item Pointer Register Description	3-12

3-16	Power Management Capabilities Register Description	3-13
3-17	Power Management Control and Status Register Description	3-14
3-18	Power Management Extension Register Description	3-14
3-19	Miscellaneous Configuration Register Description	3-15
3-20	Link Enhancement Control Register Description	3-16
3-21	Subsystem Access Register Description	3-17
3-22	GPIO Control Register Description	3-18
4-1	OHCI Register Map	4-1
4-2	OHCI Version Register Description	4-4
4-3	GUID ROM Register Description	4-5
4-4	Asynchronous Transmit Retries Register Description	4-6
4-5	CSR Control Register Description	4-7
4-6	Configuration ROM Header Register Description	4-8
4-7	Bus Options Register Description	4-9
4-8	Configuration ROM Mapping Register Description	4-11
4-9	Posted Write Address High Register Description	4-12
4-10	Host Controller Control Register Description	4-13
4-11	Self-ID Count Register Description	4-15
4-12	Isochronous Receive Channel Mask High Register Description	4-16
4-13	Isochronous Receive Channel Mask Low Register Description	4-17
4-14	Interrupt Event Register Description	4-18
4-15	Interrupt Mask Register Description	4-20
4-16	Isochronous Transmit Interrupt Event Register Description	4-21
4-17	Isochronous Receive Interrupt Event Register Description	4-22
4-18	Fairness Control Register Description	4-23
4-19	Link Control Register Description	4-24
4-20	Node Identification Register Description	4-25
4-21	PHY Control Register Description	4-26
4-22	Isochronous Cycle Timer Register Description	4-27
4-23	Asynchronous Request Filter High Register Description	4-28
4-24	Asynchronous Request Filter Low Register Description	4-30
4-25	Physical Request Filter High Register Description	4-31
4-26	Physical Request Filter Low Register Description	4-33
4-27	Asynchronous Context Control Register Description	4-34
4-28	Asynchronous Context Command Pointer Register Description	4-35
4-29	Isochronous Transmit Context Control Register Description	4-36
4-30	Isochronous Receive Context Control Register Description	4-37
4-31	Isochronous Receive Context Match Register Description	4-40
4-32	IR Digital Video Enhancements Register Description	4-41
6-1	Registers and Bits Loadable Through Serial ROM	6-1
6-2	Serial ROM Map	6-2

1 Introduction

This chapter provides an overview of the Texas Instruments TSB12LV23A device and its features.

1.1 Description

The Texas Instruments TSB12LV23A device, the OHCI-Lynx™ PCI-based IEEE 1394 host controller, is a PCI-to-1394 host controller compatible with the latest *PCI Local Bus*, *PCI Bus Power Management Interface*, IEEE 1394-1995, and *1394 Open Host Controller Interface Specifications*. The chip provides the IEEE 1394 link function and is compatible with serial bus data rates of 100 Mbits/s, 200 Mbits/s, and 400 Mbits/s.

As required by the *1394 Open Host Controller Interface Specification* (OHCI) and the IEEE 1394a-2000 specification, internal control registers are memory-mapped and nonprefetchable. The PCI configuration header is accessed through configuration cycles specified by PCI, and provides plug-and-play (PnP) compatibility. Furthermore, the TSB12LV23A device is compliant with the *PCI Bus Power Management Interface Specification*, according to the *PC 99 Design Guide* requirements. The TSB12LV23A device supports the D0, D2, and D3 power states.

The TSB12LV23A design provides PCI bus master bursting, and is capable of transferring a cacheline of data at 132 Mbytes/s after connection to the memory controller. Because PCI latency can be large, deep FIFOs are provided to buffer 1394 data.

The TSB12LV23A device provides physical write posting buffers and a highly tuned physical data path for SBP-2 performance. The TSB12LV23A device also provides multiple isochronous contexts, multiple cacheline burst transfers, advanced internal arbitration, and bus-holding buffers on the PHY/link interface.

The TSB12LV23A device implements an enhancement for formatted DV and audio/music isochronous transmissions which implement the common isochronous packet (CIP) format defined by IEC61883. The enhancements to the isochronous DMA contexts are implemented as hardware support for the synchronization time stamp for both DV and audio/music CIP formats. The TSB12LV23A device supports modification of the synchronization time stamp field to ensure that the value inserted via software is not stale, that is, less than the current cycle timer, when the packet is transmitted.

An advanced CMOS process is used to achieve low power consumption with operation at PCI clock rates up to 33 MHz.

1.2 Features

The TSB12LV23A device supports the following features:

- 3.3-V core logic with universal PCI interfaces compatible with 3.3-V and 5-V PCI signaling environments
- Supports serial bus data rates of 100, 200, and 400 Mbits/s
- Provides bus-holding buffers on physical interface for low-cost single-capacitor isolation
- Supports physical write posting of up to three outstanding transactions
- Serial ROM interface supports 2-wire devices
- Supports external cycle timer control for customized synchronization
- Implements PCI burst transfers and deep FIFOs to tolerate large host latency
- Provides two general-purpose I/Os

- Fabricated in advanced low-power CMOS process
- Packaged in 100-terminal PQFP (PZ)
- Supports $\overline{\text{PCI_CLKRUN}}$ protocol
- Drop-in replacement for the TSB12LV22 device
- Supports PCI and CardBus applications
- Digital video and audio performance enhancements

1.3 Related Documents

- *1394 Open Host Controller Interface Specification* (Revision 1.0)
- *Digital Interface for Consumer Electronic Audio/Video Equipment Draft Version 2.1* (IEC61883)
- *P1394 Standard for a High-Performance Serial Bus* (IEEE 1394–1995)
- *IEEE Standard for a High-Performance Serial Bus—Amendment 1* (IEEE 1394a-2000)
- *PC 99 Design Guide*
- *PCI Bus Power Management Interface Specification* (Revision 1.1)
- *PCI Local Bus Specification* (Revision 2.2)
- *Serial Bus Protocol 2* (SBP-2)

1.4 Trademarks

OHCI-Lynx and TI are trademarks of Texas Instruments.

Other trademarks are the property of their respective owners.

1.5 Ordering Information

ORDERING NUMBER	NAME	VOLTAGE	PACKAGE
TSB12LV23A	OHCI-Lynx™ PCI-based IEEE 1394 host controller	3.3 V, 5 V-tolerant I/Os	100-terminal PQFP

2 Terminal Descriptions

This section provides the terminal descriptions for the TSB12LV23A device. Figure 2–1 shows the signal assigned to each terminal in the package. Table 2–1 is a listing of signal names arranged by terminal number. Table 2–2 is a listing of signal names arranged in alphanumeric order.

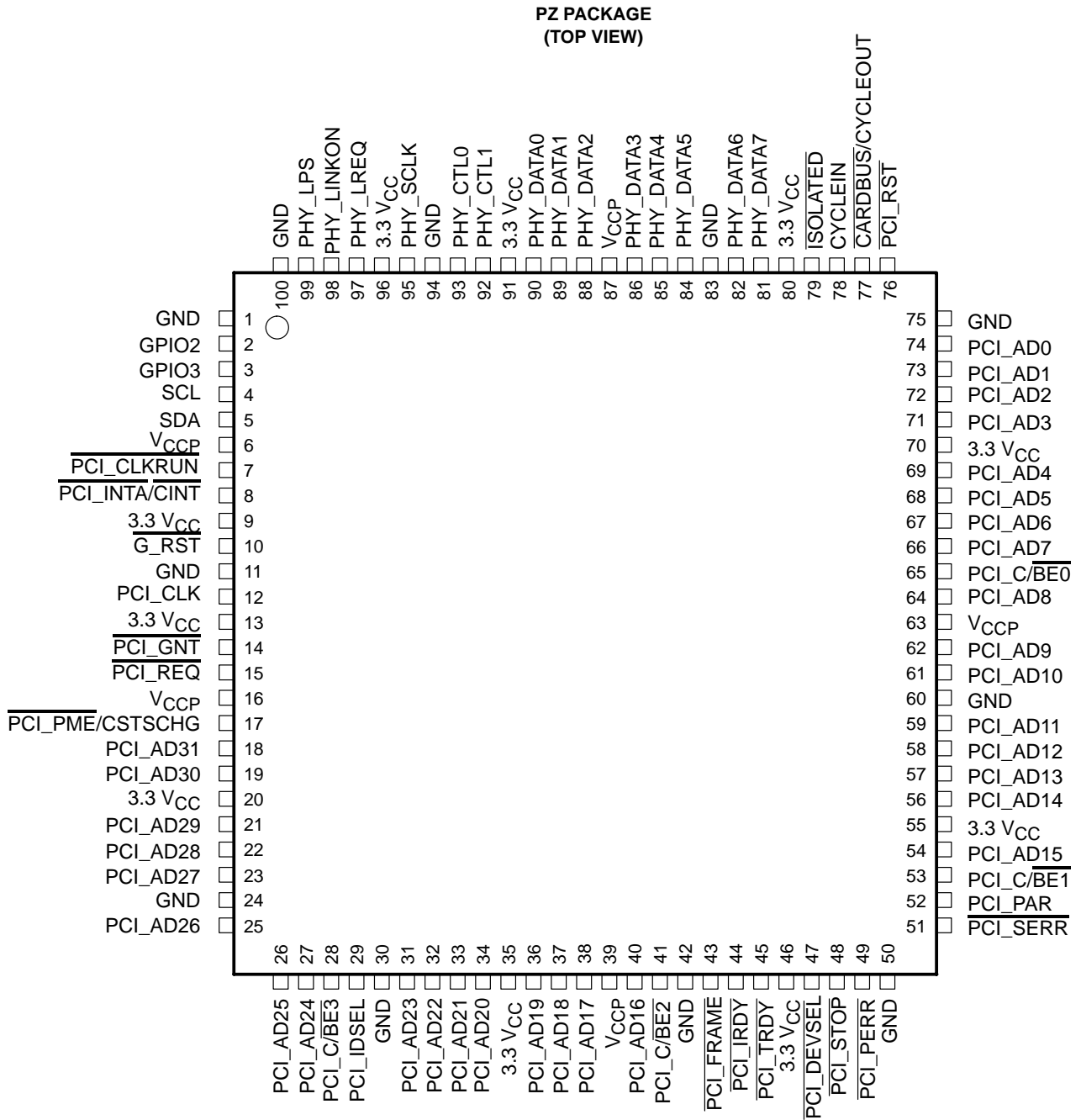

Figure 2–1. Terminal Assignments

Table 2–1. Signals Sorted by Terminal Number

NO.	TERMINAL NAME	NO.	TERMINAL NAME	NO.	TERMINAL NAME	NO.	TERMINAL NAME
1	GND	26	PCI_AD25	51	PCI_SERR	76	PCI_RST
2	GPIO2	27	PCI_AD24	52	PCI_PAR	77	CARDBUS/CYCLEOUT
3	GPIO3	28	PCI_C/BE3	53	PCI_C/BE1	78	CYCLEIN
4	SCL	29	PCI_IDSEL	54	PCI_AD15	79	ISOLATED
5	SDA	30	GND	55	3.3 V _{CC}	80	3.3 V _{CC}
6	V _{CCP}	31	PCI_AD23	56	PCI_AD14	81	PHY_DATA7
7	PCI_CLKRUN	32	PCI_AD22	57	PCI_AD13	82	PHY_DATA6
8	PCI_INTA/CINT	33	PCI_AD21	58	PCI_AD12	83	GND
9	3.3 V _{CC}	34	PCI_AD20	59	PCI_AD11	84	PHY_DATA5
10	G_RST	35	3.3 V _{CC}	60	GND	85	PHY_DATA4
11	GND	36	PCI_AD19	61	PCI_AD10	86	PHY_DATA3
12	PCI_CLK	37	PCI_AD18	62	PCI_AD9	87	V _{CCP}
13	3.3 V _{CC}	38	PCI_AD17	63	V _{CCP}	88	PHY_DATA2
14	PCI_GNT	39	V _{CCP}	64	PCI_AD8	89	PHY_DATA1
15	PCI_REQ	40	PCI_AD16	65	PCI_C/BE0	90	PHY_DATA0
16	V _{CCP}	41	PCI_C/BE2	66	PCI_AD7	91	3.3 V _{CC}
17	PCI_PME/CSTSCHG	42	GND	67	PCI_AD6	92	PHY_CTL1
18	PCI_AD31	43	PCI_FRAME	68	PCI_AD5	93	PHY_CTL0
19	PCI_AD30	44	PCI_IRDY	69	PCI_AD4	94	GND
20	3.3 V _{CC}	45	PCI_TRDY	70	3.3 V _{CC}	95	PHY_SCLK
21	PCI_AD29	46	3.3 V _{CC}	71	PCI_AD3	96	3.3 V _{CC}
22	PCI_AD28	47	PCI_DEVSEL	72	PCI_AD2	97	PHY_LREQ
23	PCI_AD27	48	PCI_STOP	73	PCI_AD1	98	PHY_LINKON
24	GND	49	PCI_PERR	74	PCI_AD0	99	PHY_LPS
25	PCI_AD26	50	GND	75	GND	100	GND

Table 2–2. Signal Names Sorted Alphanumerically to Terminal Number

TERMINAL NAME	NO.	TERMINAL NAME	NO.	TERMINAL NAME	NO.	TERMINAL NAME	NO.
$\overline{\text{CARDBUS/CYCLEOUT}}$	77	PCI_AD8	64	PCI_C/BE1	53	PHY_DATA4	85
CYCLEIN	78	PCI_AD9	62	PCI_C/BE2	41	PHY_DATA5	84
GND	1	PCI_AD10	61	PCI_C/BE3	28	PHY_DATA6	82
GND	11	PCI_AD11	59	PCI_CLK	12	PHY_DATA7	81
GND	24	PCI_AD12	58	$\overline{\text{PCI_CLKRUN}}$	7	PHY_LINKON	98
GND	30	PCI_AD13	57	$\overline{\text{PCI_DEVSEL}}$	47	PHY_LREQ	97
GND	42	PCI_AD14	56	$\overline{\text{PCI_FRAME}}$	43	PHY_LPS	99
GND	50	PCI_AD15	54	$\overline{\text{PCI_GNT}}$	14	PHY_SCLK	95
GND	60	PCI_AD16	40	PCI_IDSEL	29	SCL	4
GND	75	PCI_AD17	38	$\overline{\text{PCI_INTA/CINT}}$	8	SDA	5
GND	83	PCI_AD18	37	$\overline{\text{PCI_IRDY}}$	44	V _{CCP}	6
GND	94	PCI_AD19	36	PCI_PAR	52	V _{CCP}	16
GND	100	PCI_AD20	34	$\overline{\text{PCI_PERR}}$	49	V _{CCP}	39
GPIO2	2	PCI_AD21	33	$\overline{\text{PCI_PME/CSTSCHG}}$	17	V _{CCP}	63
GPIO3	3	PCI_AD22	32	$\overline{\text{PCI_REQ}}$	15	V _{CCP}	87
$\overline{\text{G_RST}}$	10	PCI_AD23	31	$\overline{\text{PCI_RST}}$	76	3.3 V _{CC}	9
ISOLATED	79	PCI_AD24	27	$\overline{\text{PCI_SERR}}$	51	3.3 V _{CC}	13
PCI_AD0	74	PCI_AD25	26	$\overline{\text{PCI_STOP}}$	48	3.3 V _{CC}	20
PCI_AD1	73	PCI_AD26	25	$\overline{\text{PCI_TRDY}}$	45	3.3 V _{CC}	35
PCI_AD2	72	PCI_AD27	23	PHY_CTL0	93	3.3 V _{CC}	46
PCI_AD3	71	PCI_AD28	22	PHY_CTL1	92	3.3 V _{CC}	55
PCI_AD4	69	PCI_AD29	21	PHY_DATA0	90	3.3 V _{CC}	70
PCI_AD5	68	PCI_AD30	19	PHY_DATA1	89	3.3 V _{CC}	80
PCI_AD6	67	PCI_AD31	18	PHY_DATA2	88	3.3 V _{CC}	91
PCI_AD7	66	PCI_C/BE0	65	PHY_DATA3	86	3.3 V _{CC}	96

The terminals are grouped by functionality, such as PCI system function and power supply function, in Table 2–3 through Table 2–8. The terminal numbers are also listed for convenient reference.

Table 2–3. Power Supply Terminals

TERMINAL		I/O	DESCRIPTION
NAME	NO.		
GND	1, 11, 24, 30, 42, 50, 60, 75, 83, 94, 100	I	Device ground terminals
V _{CCP}	6, 16, 39, 63, 87	I	PCI signaling clamp voltage power input. PCI signals are clamped per the <i>PCI Local Bus Specification</i> .
3.3 V _{CC}	9, 13, 20, 35, 46, 55, 70, 80, 91, 96	I	3.3-V power supply terminals

Table 2–4. PCI System Terminals

TERMINAL		I/O	DESCRIPTION
NAME	NO.		
$\overline{G_RST}$	10	I	Global power reset. This reset brings all of the TSB12LV23A internal registers to their default states, including those registers not reset by $\overline{PCI_RST}$. When $\overline{G_RST}$ is asserted, the device is completely nonfunctional. When wake capabilities are implemented from the 1394 host controller, it is necessary to implement two resets to the TSB12LV23A device. $\overline{G_RST}$ should be a one-time power-on reset.
PCI_CLK	12	I	PCI bus clock. Provides timing for all transactions on the PCI bus. All PCI signals are sampled at the rising edge of PCI_CLK.
$\overline{PCI_INTA/CINT}$	8	O	Interrupt signal. This output indicates interrupts from the TSB12LV23A device to the host. This terminal is implemented as open-drain.
$\overline{PCI_RST}$	76	I	PCI reset. When this bus reset is asserted, the TSB12LV23A device places all output buffers in a high-impedance state and resets all internal registers except device power management context and vendor-specific bits initialized by host power-on software. When $\overline{PCI_RST}$ is asserted, the device is completely nonfunctional. This terminal should be connected to the PCI bus \overline{RST} signal.

Table 2–5. PCI Address and Data Terminals

TERMINAL		I/O	DESCRIPTION
NAME	NO.		
PCI_AD31	18	I/O	PCI address/data bus. These signals make up the multiplexed PCI address and data bus on the PCI interface. During the address phase of a PCI cycle, AD31–AD0 contain a 32-bit address or other destination information. During the data phase, AD31–AD0 contain data.
PCI_AD30	19		
PCI_AD29	21		
PCI_AD28	22		
PCI_AD27	23		
PCI_AD26	25		
PCI_AD25	26		
PCI_AD24	27		
PCI_AD23	31		
PCI_AD22	32		
PCI_AD21	33		
PCI_AD20	34		
PCI_AD19	36		
PCI_AD18	37		
PCI_AD17	38		
PCI_AD16	40		
PCI_AD15	54		
PCI_AD14	56		
PCI_AD13	57		
PCI_AD12	58		
PCI_AD11	59		
PCI_AD10	61		
PCI_AD9	62		
PCI_AD8	64		
PCI_AD7	66		
PCI_AD6	67		
PCI_AD5	68		
PCI_AD4	69		
PCI_AD3	71		
PCI_AD2	72		
PCI_AD1	73		
PCI_AD0	74		

Table 2–6. PCI Interface Control Terminals

TERMINAL		I/O	DESCRIPTION
NAME	NO.		
PCI_C/BE0 PCI_C/BE1 PCI_C/BE2 PCI_C/BE3	65 53 41 28	I/O	PCI bus commands and byte enables. The command and byte enable signals are multiplexed on the same PCI terminals. During the address phase of a bus cycle, PCI_C/BE3–PCI_C/BE0 define the bus command. During the data phase, this 4-bit bus is used as byte enables.
PCI_CLKRUN	7	I/O	Clock run. This terminal provides clock control through the PCI_CLKRUN protocol. An internal pull-down resistor is implemented on this terminal. This terminal is implemented as open-drain.
PCI_DEVSEL	47	I/O	PCI device select. The TSB12LV23A device asserts this signal to claim a PCI cycle as the target device. As a PCI initiator, the TSB12LV23A device monitors this signal until a target responds. If no target responds before timeout occurs, then the TSB12LV23A device terminates the cycle with an initiator abort.
PCI_FRAME	43	I/O	PCI cycle frame. This signal is driven by the initiator of a PCI bus cycle. PCI_FRAME is asserted to indicate that a bus transaction is beginning, and data transfers continue while this signal is asserted. When PCI_FRAME is de-asserted, the PCI bus transaction is in the final data phase.
PCI_GNT	14	I	PCI bus grant. This signal is driven by the PCI bus arbiter to grant the TSB12LV23A device access to the PCI bus after the current data transaction has completed. This signal may or may not follow a PCI bus request, depending upon the PCI bus parking algorithm.
PCI_IDSEL	29	I	Initialization device select. PCI_IDSEL selects the TSB12LV23A device during configuration space accesses. PCI_IDSEL can be connected to 1 of the upper 24 PCI address lines on the PCI bus.
PCI_IRDY	44	I/O	PCI initiator ready. PCI_IRDY indicates the ability of the PCI bus initiator to complete the current data phase of the transaction. A data phase is completed upon a rising edge of PCI_CLK where both PCI_IRDY and PCI_TRDY are asserted.
PCI_PAR	52	I/O	PCI parity. In all PCI bus read and write cycles, the TSB12LV23A device calculates even parity across the PCI_AD and PCI_C/BE buses. As an initiator during PCI cycles, the TSB12LV23A device outputs this parity indicator with a one-PCI_CLK delay. As a target during PCI cycles, the calculated parity is compared to the initiator parity indicator; a mismatch can result in a parity error assertion (PCI_PERR).
PCI_PERR	49	I/O	PCI parity error indicator. This signal is driven by a PCI device to indicate that calculated parity does not match PCI_PAR when bit 6 (PERR_ENB) is set in the command register (offset 04h, see Section 3.4).
PCI_PME/ CSTSCHG	17	O	Power management event or card status change. This terminal indicates wake events to the host. When in a CardBus configuration, per the CARDBUS sample, the CSTSCHG output is an active high.
PCI_REQ	15	O	PCI bus request. Asserted by the TSB12LV23A device to request access to the bus as an initiator. The host arbiter asserts the PCI_GNT signal when the TSB12LV23A device has been granted access to the bus.
PCI_SERR	51	O	PCI system error. When bit 8 (SERR_ENB) of the command register (offset 04h, see Section 3.4) is set, the output is pulsed, which indicates an address parity error has occurred. The TSB12LV23A device need not be the target of the PCI cycle to assert this signal. This terminal is implemented as open-drain.
PCI_STOP	48	I/O	PCI cycle stop signal. This signal is driven by a PCI target to request the initiator to stop the current PCI bus transaction. This signal is used for target disconnects, and is commonly asserted by target devices which do not support burst data transfers.
PCI_TRDY	45	I/O	PCI target ready. PCI_TRDY indicates the ability of the PCI bus target to complete the current data phase of the transaction. A data phase is completed upon a rising edge of PCI_CLK where both PCI_IRDY and PCI_TRDY are asserted; until which wait states are inserted.

Table 2–7. IEEE 1394 PHY/Link Terminals

TERMINAL		I/O	DESCRIPTION
NAME	NO.		
PHY_CTL1 PHY_CTL0	92 93	I/O	PHY-link interface control. These bidirectional signals control passage of information between the two devices. The TSB12LV23A device can only drive these terminals after the PHY device has granted permission following a link request (PHY_LREQ).
PHY_DATA7 PHY_DATA6 PHY_DATA5 PHY_DATA4 PHY_DATA3 PHY_DATA2 PHY_DATA1 PHY_DATA0	81 82 84 85 86 88 89 90	I/O	PHY-link interface data. These bidirectional signals pass data between the TSB12LV23A and the PHY devices. These terminals are driven by the TSB12LV23A device on transmissions and are driven by the PHY device on reception. Only PHY_DATA1–PHY_DATA0 are valid for 100-Mbit speeds, PHY_DATA3–PHY_DATA0 are valid for 200-Mbit speeds, and PHY_DATA7–PHY_DATA0 are valid for 400-Mbit speeds.
PHY_LINKON	98	I/O	LinkOn wake indication. The PHY_LINKON signal is pulsed by the PHY device to activate the link, and 3.3-V signaling is required. When this signal is connected to the TSB41LV0X C/LKON terminal, a 1-k Ω series resistor is required between the link and the PHY device.
PHY_LPS	99	I/O	Link power status. The PHY_LPS signal is asserted when the link is powered on, and 3.3-V signaling is required.
PHY_LREQ	97	O	Link request. This signal is driven by the TSB12LV23A device to initiate a request for the PHY device to perform some service.
PHY_SCLK	95	I	System clock. This input from the PHY device provides a 49.152-MHz clock signal for data synchronization.

Table 2–8. Miscellaneous Terminals

TERMINAL		I/O	DESCRIPTION
NAME	NO.		
$\overline{\text{CARDBUS/}}$ CYCLEOUT	77	I/O	This terminal is sampled when $\overline{\text{G_RST}}$ is asserted, and it selects between PCI buffers and CardBus buffers. After reset, this terminal may also function as CYCLEOUT, which provides an 8-kHz cycle timer synchronization signal.
CYCLEIN	78	I/O	The CYCLEIN terminal allows an external 8-kHz clock to be used as a cycle timer for synchronization with other system devices. If this terminal is not implemented, then it should be pulled high to the link V_{CC} through a 4.7-k Ω resistor.
GPIO2	2	I/O	General-purpose I/O [2]. This terminal defaults as an input and if it is not implemented, then it is recommended that it be pulled low to ground with a 220- Ω resistor.
GPIO3	3	I/O	General-purpose I/O [3]. This terminal defaults as an input and if it is not implemented, then it is recommended that it be pulled low to ground with a 220- Ω resistor.
$\overline{\text{ISOLATED}}$	79	I	For isolated designs, the busholders are implemented by pulling this terminal low to ground with a 220- Ω resistor. If this terminal is not implemented, it should be pulled high to the link V_{CC} with a 4.7-k Ω resistor.
SCL	4	I/O	Serial clock. This terminal provides the serial clock signaling and is implemented as open-drain. For normal operation (a ROM is implemented in the design), this terminal should be pulled high to the ROM V_{CC} with a 2.7-k Ω resistor. Otherwise, it should be pulled low to ground with a 220- Ω resistor.
SDA	5	I/O	Serial data. At $\overline{\text{PCI_RST}}$, the SDA signal is sampled to determine if a two-wire serial ROM is present. If the serial ROM is detected, then this terminal provides the serial data signaling. This terminal is implemented as open-drain, and for normal operation (a ROM is implemented in the design), this terminal should be pulled high to the ROM V_{CC} with a 2.7-k Ω resistor. Otherwise, it should be pulled low to ground with a 220- Ω resistor.

3 TSB12LV23A Controller Programming Model

This section describes the PCI internal registers used to program the TSB12LV23A device. All registers are detailed in the same format: a brief description for each register, followed by the register offset and a bit table describing the reset state for each register.

A bit description table, typically included when the register contains bits of more than one type or purpose, indicates bit field names, field access tags which appear in the *type* column, and a detailed field description. Table 3–1 describes the field access tags.

Table 3–1. Bit Field Access Tag Descriptions

ACCESS TAG	NAME	MEANING
R	Read	Field may be read by software.
W	Write	Field may be written by software to any value.
S	Set	Field may be set by a write of 1. Writes of 0 have no effect.
C	Clear	Field may be cleared by a write of 1. Writes of 0 have no effect.
U	Update	Field may be autonomously updated by the TSB12LV23A device.

A simplified block diagram of the TSB12LV23A device is provided in Figure 3–1.

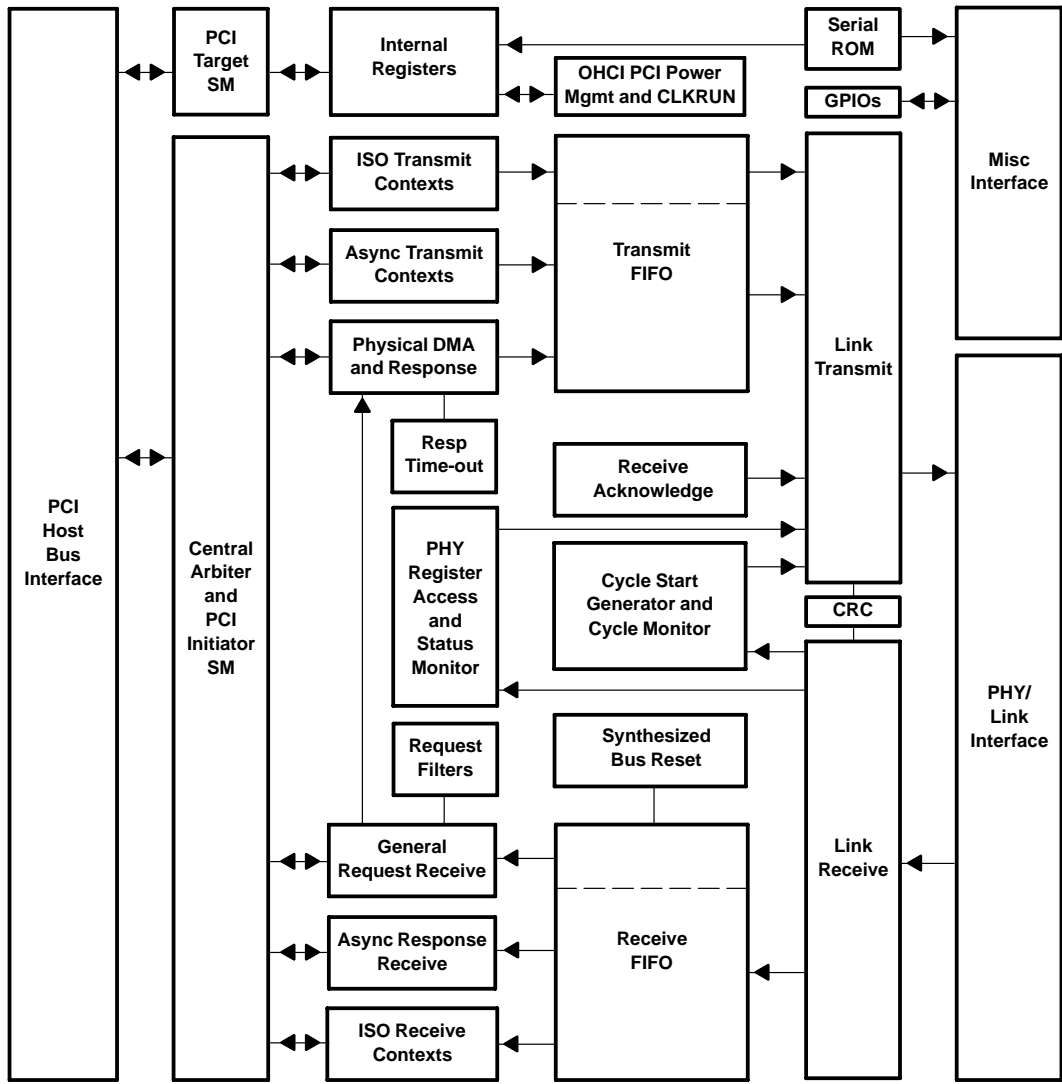

Figure 3–1. TSB12LV23A Block Diagram

3.1 PCI/CardBus Configuration Registers

The TSB12LV23A device is a single-function PCI device that can be configured as either a PCI or CardBus device. The configuration header is compliant with the *PCI Local Bus Specification* as a standard header. Table 3–2 illustrates the PCI configuration header that includes both the predefined portion of the configuration space and the user-definable registers. Most of the registers in this configuration have not changed from the TSB12LV22 design.

Table 3–2. PCI Configuration Register Map

REGISTER NAME				OFFSET
Device ID		Vendor ID		00h
Status		Command		04h
Class code			Revision ID	08h
BIST	Header type	Latency timer	Cache line size	0Ch
OHCI base address				10h
TI extension base address				14h
CIS base address				18h
Reserved				1Ch–24h
CardBus CIS pointer				28h
Subsystem device ID		Subsystem vendor ID		2Ch
Reserved				30h
Reserved			Power management capabilities pointer	34h
Reserved				38h
Maximum latency	Minimum grant	Interrupt pin	Interrupt line	3Ch
OHCI control				40h
Power management capabilities		Next item pointer	Capability ID	44h
PM data	PMCSR_BSE	Power management control and status		48h
Reserved				4Ch–ECh
Miscellaneous configuration				F0h
Link enhancements control				F4h
Subsystem device ID alias		Subsystem vendor ID alias		F8h
GPIO3	GPIO2	Reserved		FCh

3.2 Vendor ID Register

The vendor ID register contains a value allocated by the PCI SIG and identifies the manufacturer of the PCI device. The vendor ID assigned to Texas Instruments is 104Ch.

Bit	15	14	13	12	11	10	9	8	7	6	5	4	3	2	1	0
Name	Vendor ID															
Type	R	R	R	R	R	R	R	R	R	R	R	R	R	R	R	R
Default	0	0	0	1	0	0	0	0	0	1	0	0	1	1	0	0

Register: **Vendor ID**
 Type: Read-only
 Offset: 00h
 Default: 104Ch

3.3 Device ID Register

The device ID register contains a value assigned to the TSB12LV23A device by Texas Instruments. The device identification for the TSB12LV23A device is 8019h.

Bit	15	14	13	12	11	10	9	8	7	6	5	4	3	2	1	0
Name	Device ID															
Type	R	R	R	R	R	R	R	R	R	R	R	R	R	R	R	R
Default	1	0	0	0	0	0	0	0	0	0	0	1	1	0	0	1

Register: **Device ID**
 Type: Read-only
 Offset: 02h
 Default: 8019h

3.4 Command Register

The command register provides control over the TSB12LV23A interface to the PCI bus. All bit functions adhere to the definitions in the *PCI Local Bus Specification*, as seen in the bit descriptions of Table 3–3.

Bit	15	14	13	12	11	10	9	8	7	6	5	4	3	2	1	0
Name	Command															
Type	R	R	R	R	R	R	R	R/W	R	R/W	R	R/W	R	R/W	R/W	R
Default	0	0	0	0	0	0	0	0	0	0	0	0	0	0	0	0

Register: **Command**
 Type: Read/Write, Read-only
 Offset: 04h
 Default: 0000h

Table 3–3. Command Register Description

BIT	FIELD NAME	TYPE	DESCRIPTION
15–10	RSVD	R	Reserved. Bits 15–10 return 0s when read.
9	FBB_ENB	R	Fast back-to-back enable. The TSB12LV23A device does not generate fast back-to-back transactions; therefore, this bit returns 0 when read.
8	SERR_ENB	R/W	$\overline{\text{PCI_SERR}}$ enable. When this bit is set, the TSB12LV23A $\overline{\text{PCI_SERR}}$ driver is enabled. $\overline{\text{PCI_SERR}}$ can be asserted after an address parity error on the PCI bus is detected.
7	STEP_ENB	R	Address/data stepping control. The TSB12LV23A device does not support address/data stepping; therefore, this bit is hardwired to 0.
6	PERR_ENB	R/W	Parity error enable. When this bit is set, the TSB12LV23A device is enabled to drive $\overline{\text{PCI_PERR}}$ response to parity errors through the $\overline{\text{PCI_PERR}}$ signal.
5	VGA_ENB	R	VGA palette snoop enable. The TSB12LV23A device does not feature VGA palette snooping. This bit returns 0 when read.
4	MWI_ENB	R/W	Memory write and invalidate enable. When this bit is set, the TSB12LV23A device is enabled to generate MWI PCI bus commands. If this bit is cleared, then the TSB12LV23A device generates memory write commands instead.
3	SPECIAL	R	Special cycle enable. The TSB12LV23A function does not respond to special cycle transactions. This bit returns 0 when read.
2	MASTER_ENB	R/W	Bus master enable. When this bit is set, the TSB12LV23A device is enabled to initiate cycles on the PCI bus.
1	MEMORY_ENB	R/W	Memory response enable. Setting this bit enables the TSB12LV23A device to respond to memory cycles on the PCI bus. This bit must be set to access OHCI registers.
0	IO_ENB	R	I/O space enable. The TSB12LV23A device does not implement any I/O mapped functionality; therefore, this bit returns 0 when read.

3.5 Status Register

The status register provides status over the TSB12LV23A interface to the PCI bus. All bit functions adhere to the definitions in the *PCI Local Bus Specification*, as seen in the bit descriptions of Table 3–4.

Bit	15	14	13	12	11	10	9	8	7	6	5	4	3	2	1	0
Name	Status															
Type	RCU	RCU	RCU	RCU	RCU	R	R	RCU	R	R	R	R	R	R	R	R
Default	0	0	0	0	0	0	1	0	0	0	0	1	0	0	0	0

Register: **Status**
 Type: Read/Clear/Update, Read-only
 Offset: 06h
 Default: 0210h

Table 3–4. Status Register Description

BIT	FIELD NAME	TYPE	DESCRIPTION
15	PAR_ERR	RCU	Detected parity error. This bit is set when either an address parity or data parity error is detected.
14	SYS_ERR	RCU	Signaled system error. This bit is set when $\overline{\text{PCI_SERR}}$ is enabled and the TSB12LV23A device has signaled a system error to the host.
13	MABORT	RCU	Received master abort. This bit is set when a cycle initiated by the TSB12LV23A device on the PCI bus has been terminated by a master abort.
12	TABORT_REC	RCU	Received target abort. This bit is set when a cycle initiated by the TSB12LV23A device on the PCI bus was terminated by a target abort.
11	TABORT_SIG	RCU	Signaled target abort. This bit is set by the TSB12LV23A device when it terminates a transaction on the PCI bus with a target abort.
10–9	PCI_SPEED	R	DEVSEL timing. Bits 10–9 encode the timing of $\overline{\text{PCI_DEVSEL}}$ and are hardwired to 01b indicating that the TSB12LV23A device asserts this signal at a medium speed on nonconfiguration cycle accesses.
8	DATAPAR	RCU	Data parity error detected. This bit is set when the following conditions have been met: a. PCI_PERR was asserted by any PCI device including the TSB12LV23A device. b. The TSB12LV23A device was the bus master during the data parity error. c. Bit 6 (PERR_EN) is set in the command register (offset 04h, see Section 3.4).
7	FBB_CAP	R	Fast back-to-back capable. The TSB12LV23A device cannot accept fast back-to-back transactions; therefore, this bit is hardwired to 0.
6	UDF	R	User-definable features (UDF) supported. The TSB12LV23A device does not support the UDF; therefore, this bit is hardwired to 0.
5	66MHZ	R	66-MHz capable. The TSB12LV23A device operates at a maximum PCI_CLK frequency of 33 MHz; therefore, this bit is hardwired to 0.
4	CAPLIST	R	Capabilities list. This bit returns 1 when read, indicating that capabilities additional to standard PCI are implemented. The linked list of PCI power management capabilities is implemented in this function.
3–0	RSVD	R	Reserved. Bits 3–0 return 0s when read.

3.6 Class Code and Revision ID Register

The class code and revision ID register categorizes the TSB12LV23A device as a serial bus controller (0Ch), controlling an IEEE 1394 bus (00h), with an OHCI programming model (10h). Furthermore, the TI chip revision is indicated in the least significant byte. See Table 3–5 for a complete description of the register contents.

Bit	31	30	29	28	27	26	25	24	23	22	21	20	19	18	17	16
Name	Class code and revision ID															
Type	R	R	R	R	R	R	R	R	R	R	R	R	R	R	R	R
Default	0	0	0	0	1	1	0	0	0	0	0	0	0	0	0	0
Bit	15	14	13	12	11	10	9	8	7	6	5	4	3	2	1	0
Name	Class code and revision ID															
Type	R	R	R	R	R	R	R	R	R	R	R	R	R	R	R	R
Default	0	0	0	1	0	0	0	0	0	0	0	0	0	0	0	0

Register: **Class code and revision ID**
 Type: Read-only
 Offset: 08h
 Default: 0C00 1000h

Table 3–5. Class Code and Revision ID Register Description

BIT	FIELD NAME	TYPE	DESCRIPTION
31–24	BASECLASS	R	Base class. This field returns 0Ch when read, which broadly classifies the function as a serial bus controller.
23–16	SUBCLASS	R	Subclass. This field returns 00h when read, which specifically classifies the function as controlling an IEEE 1394 serial bus.
15–8	PGMIF	R	Programming interface. This field returns 10h when read, indicating that the programming model is compliant with the <i>1394 Open Host Controller Interface Specification</i> .
7–0	CHIPREV	R	Silicon revision. This field returns 00h when read, indicating the silicon revision of the TSB12LV23A device.

3.7 Latency Timer and Class Cache Line Size Register

The latency timer and class cache line size register is programmed by host BIOS to indicate system cache line size and the latency timer associated with the TSB12LV23A device. See Table 3–6 for a complete description of the register contents.

Bit	15	14	13	12	11	10	9	8	7	6	5	4	3	2	1	0
Name	Latency timer and class cache line size															
Type	R/W	R/W	R/W	R/W	R/W	R/W	R/W	R/W	R/W	R/W	R/W	R/W	R/W	R/W	R/W	R/W
Default	0	0	0	0	0	0	0	0	0	0	0	0	0	0	0	0

Register: **Latency timer and class cache line size**
 Type: Read/Write
 Offset: 0Ch
 Default: 0000h

Table 3–6. Latency Timer and Class Cache Line Size Register Description

BIT	FIELD NAME	TYPE	DESCRIPTION
15–8	LATENCY_TIMER	R/W	PCI latency timer. The value in this register specifies the latency timer for the TSB12LV23A device, in units of PCI clock cycles. When the TSB12LV23A device is a PCI bus initiator and asserts <code>PCI_FRAME</code> , the latency timer begins counting from zero. If the latency timer expires before the TSB12LV23A transaction has terminated, then the TSB12LV23A device terminates the transaction when its <code>PCI_GNT</code> is deasserted.
7–0	CACHELINE_SZ	R/W	Cache line size. This value is used by the TSB12LV23A device during memory write and invalidate, memory read line, and memory read multiple transactions.

3.8 Header Type and BIST Register

The header type and BIST register indicates the TSB12LV23A PCI header type, and indicates no built-in self-test. See Table 3–7 for a complete description of the register contents.

Bit	15	14	13	12	11	10	9	8	7	6	5	4	3	2	1	0
Name	Header type and BIST															
Type	R	R	R	R	R	R	R	R	R	R	R	R	R	R	R	R
Default	0	0	0	0	0	0	0	0	0	0	0	0	0	0	0	0

Register: **Header type and BIST**
 Type: Read-only
 Offset: 0Eh
 Default: 0000h

Table 3–7. Header Type and BIST Register Description

BIT	FIELD NAME	TYPE	DESCRIPTION
15–8	BIST	R	Built-in self-test. The TSB12LV23A device does not include a built-in self-test; thus, this field returns 00h when read.
7–0	HEADER_TYPE	R	PCI header type. The TSB12LV23A device includes the standard PCI header, and this is communicated by returning 00h when this field is read.

3.9 OHCI Base Address Register

The OHCI base address register is programmed with a base address referencing the memory-mapped OHCI control. When BIOS writes all 1s to this register, the value read back is FFFF F800h, indicating that at least 2K bytes of memory address space are required for the OHCI registers. See Table 3–8 for a complete description of the register contents.

Bit	31	30	29	28	27	26	25	24	23	22	21	20	19	18	17	16
Name	OHCI base address															
Type	R/W	R/W	R/W	R/W	R/W	R/W	R/W	R/W	R/W	R/W	R/W	R/W	R/W	R/W	R/W	R/W
Default	0	0	0	0	0	0	0	0	0	0	0	0	0	0	0	0
Bit	15	14	13	12	11	10	9	8	7	6	5	4	3	2	1	0
Name	OHCI address															
Type	R/W	R/W	R/W	R/W	R/W	R	R	R	R	R	R	R	R	R	R	R
Default	0	0	0	0	0	0	0	0	0	0	0	0	0	0	0	0

Register: **OHCI base address**
 Type: Read/Write, Read-only
 Offset: 10h
 Default: 0000 0000h

Table 3–8. OHCI Base Address Register Description

BIT	FIELD NAME	TYPE	DESCRIPTION
31–11	OHCIREG_PTR	R/W	OHCI register pointer. Specifies the upper 21 bits of the 32-bit OHCI base address register.
10–4	OHCI_SZ	R	OHCI register size. This field returns 0s when read, indicating that the OHCI registers require a 2-Kbyte region of memory.
3	OHCI_PF	R	OHCI register prefetch. This bit returns 0 when read, indicating that the OHCI registers are nonprefetchable.
2–1	OHCI_MEMTYPE	R	OHCI memory type. This field returns 0s when read, indicating that the OHCI base address register is 32 bits wide and mapping can be done anywhere in the 32-bit memory space.
0	OHCI_MEM	R	OHCI memory indicator. This bit returns 0 when read, indicating that the OHCI registers are mapped into system memory space.

3.10 TI Extension Base Address Register

The TI extension base address register is programmed with a base address referencing the memory-mapped TI extension registers. See the *OHCI Base Address Register*, Section 3.9, for bit field details.

Bit	31	30	29	28	27	26	25	24	23	22	21	20	19	18	17	16
Name	TI extension base address															
Type	R/W	R/W	R/W	R/W	R/W	R/W	R/W	R/W	R/W	R/W	R/W	R/W	R/W	R/W	R/W	R/W
Default	0	0	0	0	0	0	0	0	0	0	0	0	0	0	0	0
Bit	15	14	13	12	11	10	9	8	7	6	5	4	3	2	1	0
Name	TI extension base address															
Type	R/W	R/W	R/W	R/W	R/W	R	R	R	R	R	R	R	R	R	R	R
Default	0	0	0	0	0	0	0	0	0	0	0	0	0	0	0	0

Register: **TI extension base address**
 Type: Read/Write, Read-only
 Offset: 14h
 Default: 0000 0000h

3.11 CIS Base Address Register

If $\overline{\text{CARDBUS}}$ is sampled high on a $\overline{\text{G_RST}}$, then this 32-bit register returns 0s when read. If $\overline{\text{CARDBUS}}$ is sampled low, then this register is to be programmed with a base address referencing the memory-mapped CIS. This register must be programmed with a nonzero value before the CIS may be accessed. See Table 3–9 for a complete description of the register contents.

Bit	31	30	29	28	27	26	25	24	23	22	21	20	19	18	17	16
Name	CIS base address															
Type	R/W	R/W	R/W	R/W	R/W	R/W	R/W	R/W	R/W	R/W	R/W	R/W	R/W	R/W	R/W	R/W
Default	0	0	0	0	0	0	0	0	0	0	0	0	0	0	0	0
Bit	15	14	13	12	11	10	9	8	7	6	5	4	3	2	1	0
Name	CIS base address															
Type	R/W	R/W	R/W	R/W	R/W	R	R	R	R	R	R	R	R	R	R	R
Default	0	0	0	0	0	0	0	0	0	0	0	0	0	0	0	0

Register: **CIS base address**
 Type: Read/Write, Read-only
 Offset: 18h
 Default: 0000 0000h

Table 3–9. CIS Base Address Register Description

BIT	FIELD NAME	TYPE	DESCRIPTION
31–11	CIS_BASE	R/W	CIS base address. Specifies the upper 21 bits of the 32-bit CIS base address. If the $\overline{\text{CARDBUS}}$ input is sampled high on a $\overline{\text{G_RST}}$, then this field is read-only, returning 0s when read.
10–4	CIS_SZ	R	CIS address space size. This field returns 0s when read, indicating that the CIS space requires a 2-Kbyte region of memory.
3	CIS_PF	R	CIS prefetch. This bit returns 0 when read, indicating that the CIS is nonprefetchable. Furthermore, the CIS is a byte-accessible address space, and doubleword or 16-bit word access yields indeterminate results.
2–1	CIS_MEMTYPE	R	CIS memory type. This field returns 0s when read, indicating that the CIS base address register is 32 bits wide and mapping can be done anywhere in the 32-bit memory space.
0	CIS_MEM	R	CIS memory indicator. This bit returns 0 when read, indicating that the CIS is mapped into system memory space.

3.12 CardBus CIS Pointer Register

The $\overline{\text{CARDBUS}}$ input to the TSB12LV23A device is sampled at $\overline{\text{G_RST}}$ to determine the TSB12LV23A application. If $\overline{\text{CARDBUS}}$ is sampled high, then this register is read-only returning 0s when read. If $\overline{\text{CARDBUS}}$ is sampled low, then this register is the CardBus card information structure pointer. See Table 3–10 for a complete description of the register contents.

Bit	31	30	29	28	27	26	25	24	23	22	21	20	19	18	17	16
Name	CardBus CIS pointer															
Type	R	R	R	R	R	R	R	R	R	R	R	R	R	R	R	R
Default	0	0	0	0	0	0	0	0	0	0	0	0	0	0	0	0
Bit	15	14	13	12	11	10	9	8	7	6	5	4	3	2	1	0
Name	CardBus CIS pointer															
Type	R	R	R	R	R	R	R	R	R	R	R	R	R	R	R	R
Default	0	0	0	0	0	0	0	0	0	0	0	0	0	X	X	X

Register: **CardBus CIS pointer**

Type: Read-only

Offset: 28h

Default: 0000 000Xh

Table 3–10. CardBus CIS Pointer Register Description

BIT	FIELD NAME	TYPE	DESCRIPTION
31–28	ROM_IMAGE	R	Since the CIS is not implemented as a ROM image, this field returns 0s when read.
27–3	CIS_OFFSET	R	This field indicates the offset into the CIS address space where the CIS begins, and bits 7–3 are loaded from the serial ROM field CIS_Offset (7–3). This implementation allows the TSB12LV23A device to produce serial ROM addresses equal to the lower PCI address byte to acquire data from the serial ROM.
2–0	CIS_INDICATOR	R	This field indicates the address space where the CIS resides and returns 011b if $\overline{\text{CARDBUS}}$ is sampled low during a $\overline{\text{G_RST}}$ reset. If $\overline{\text{CARDBUS}}$ is sampled high during a $\overline{\text{G_RST}}$, then this field returns 000b when read.

3.13 Subsystem Identification Register

The subsystem identification register is used for system and option card identification purposes. This register can be initialized from the serial ROM or programmed via the subsystem ID and subsystem vendor ID alias registers (offset F8h, see Section 3.24). See Table 3–11 for a complete description of the register contents.

Bit	31	30	29	28	27	26	25	24	23	22	21	20	19	18	17	16
Name	Subsystem identification															
Type	RU	RU	RU	RU	RU	RU	RU	RU	RU	RU	RU	RU	RU	RU	RU	RU
Default	0	0	0	0	0	0	0	0	0	0	0	0	0	0	0	0
Bit	15	14	13	12	11	10	9	8	7	6	5	4	3	2	1	0
Name	Subsystem identification															
Type	RU	RU	RU	RU	RU	RU	RU	RU	RU	RU	RU	RU	RU	RU	RU	RU
Default	0	0	0	0	0	0	0	0	0	0	0	0	0	0	0	0

Register: **Subsystem identification**
 Type: Read/Update
 Offset: 2Ch
 Default: 0000 0000h

Table 3–11. Subsystem Identification Register Description

BIT	FIELD NAME	TYPE	DESCRIPTION
31–16	OHCI_SSID	RU	Subsystem device ID. This field indicates the subsystem device ID.
15–0	OHCI_SSVID	RU	Subsystem vendor ID. This field indicates the subsystem vendor ID.

3.14 Power Management Capabilities Pointer Register

The power management capabilities pointer register provides a pointer into the PCI configuration header where the PCI power management register block resides. The TSB12LV23A configuration header doublewords at offsets 44h and 48h provide the power management registers. This register is read-only and returns 44h when read.

Bit	7	6	5	4	3	2	1	0
Name	Power management capabilities pointer							
Type	R	R	R	R	R	R	R	R
Default	0	1	0	0	0	1	0	0

Register: **Power management capabilities pointer**
 Type: Read-only
 Offset: 34h
 Default: 44h

3.15 Interrupt Line and Pin Register

The interrupt line and pin register is used to communicate interrupt line routing information. See Table 3–12 for a complete description of the register contents.

Bit	15	14	13	12	11	10	9	8	7	6	5	4	3	2	1	0
Name	Interrupt line and pin															
Type	R	R	R	R	R	R	R	R	R/W	R/W	R/W	R/W	R/W	R/W	R/W	R/W
Default	0	0	0	0	0	0	0	0	1	0	0	0	0	0	0	0

Register: **Interrupt line and pin**
 Type: Read/Write, Read-only
 Offset: 3Ch
 Default: 0100h

Table 3–12. Interrupt Line and Pin Register Description

BIT	FIELD NAME	TYPE	DESCRIPTION
15–8	INTR_PIN	R	Interrupt pin. Returns 01h when read, indicating that the TSB12LV23A PCI function signals interrupts on the PCI_INTA terminal.
7–0	INTR_LINE	R/W	Interrupt line. This field is programmed by the system and indicates to software which interrupt line the TSB12LV23A PCI_INTA is connected to.

3.16 MIN_GNT and MAX_LAT Register

The MIN_GNT and MAX_LAT register is used to communicate to the system the desired setting of bits 15–8 of the latency timer and class cache line size register (offset 0Ch, see Section 3.7). If a serial ROM is detected, then the contents of this register are loaded through the serial ROM interface after a $\overline{\text{PCI_RST}}$. If no serial ROM is detected, then this register returns a default value that corresponds to MAX_LAT = 4, MIN_GNT = 2. See Table 3–13 for a complete description of the register contents.

Bit	15	14	13	12	11	10	9	8	7	6	5	4	3	2	1	0
Name	MIN_GNT and MAX_LAT															
Type	RU	RU	RU	RU	RU	RU	RU	RU	RU	RU	RU	RU	RU	RU	RU	RU
Default	0	0	0	0	0	1	0	0	0	0	0	0	0	0	1	0

Register: **MIN_GNT and MAX_LAT**
 Type: Read/Update
 Offset: 3Eh
 Default: 0402h

Table 3–13. MIN_GNT and MAX_LAT Register Description

BIT	FIELD NAME	TYPE	DESCRIPTION
15–8	MAX_LAT	RU	Maximum latency. The contents of this register may be used by host BIOS to assign an arbitration priority-level to the TSB12LV23A device. The default for this register indicates that the TSB12LV23A device may need to access the PCI bus as often as every 0.25 μs ; thus, an extremely high priority level is requested. The contents of this field may also be loaded through the serial ROM.
7–0	MIN_GNT	RU	Minimum grant. The contents of this register may be used by host BIOS to assign a latency timer and class cache line size register (offset 0Ch, see Section 3.7) value to the TSB12LV23A device. The default for this register indicates that the TSB12LV23A device may need to sustain burst transfers for nearly 64 μs ; thus, requesting a large value be programmed in bits 15–8 of the TSB12LV23A latency timer and class cache line size register.

3.17 OHCI Control Register

The OHCI control register is defined by the *1394 Open Host Controller Interface Specification* and provides a bit for big endian PCI support. See Table 3–14 for a complete description of the register contents.

Bit	31	30	29	28	27	26	25	24	23	22	21	20	19	18	17	16
Name	OHCI control															
Type	R	R	R	R	R	R	R	R	R	R	R	R	R	R	R	R
Default	0	0	0	0	0	0	0	0	0	0	0	0	0	0	0	0
Bit	15	14	13	12	11	10	9	8	7	6	5	4	3	2	1	0
Name	OHCI control															
Type	R	R	R	R	R	R	R	R	R	R	R	R	R	R	R	R/W
Default	0	0	0	0	0	0	0	0	0	0	0	0	0	0	0	0

Register: **OHCI control**
 Type: Read/Write, Read-only
 Offset: 40h
 Default: 0000 0000h

Table 3–14. OHCI Control Register Description

BIT	FIELD NAME	TYPE	DESCRIPTION
31–1	RSVD	R	Reserved. Bits 31–1 return 0s when read.
0	GLOBAL_SWAP	R/W	When this bit is set, all quadlets read from and written to the PCI interface are byte swapped (big endian). This bit is loaded from ROM and should be cleared for normal operation.

3.18 Capability ID and Next Item Pointer Register

The capability ID and next item pointer register identifies the linked list capability item and provides a pointer to the next capability item. See Table 3–15 for a complete description of the register contents.

Bit	15	14	13	12	11	10	9	8	7	6	5	4	3	2	1	0
Name	Capability ID and next item pointer															
Type	R	R	R	R	R	R	R	R	R	R	R	R	R	R	R	R
Default	0	0	0	0	0	0	0	0	0	0	0	0	0	0	0	1

Register: **Capability ID and next item pointer**
 Type: Read-only
 Offset: 44h
 Default: 0001h

Table 3–15. Capability ID and Next Item Pointer Register Description

BIT	FIELD NAME	TYPE	DESCRIPTION
15–8	NEXT_ITEM	R	Next item pointer. The TSB12LV23A device supports only one additional capability that is communicated to the system through the extended capabilities list; thus, this field returns 00h when read.
7–0	CAPABILITY_ID	R	Capability identification. This field returns 01h when read, which is the unique ID assigned by the PCI SIG for PCI power management capability.

3.19 Power Management Capabilities Register

The power management capabilities register indicates the capabilities of the TSB12LV23A device related to PCI power management. See Table 3–16 for a complete description of the register contents.

Bit	15	14	13	12	11	10	9	8	7	6	5	4	3	2	1	0
Name	Power management capabilities															
Type	RU	RU	RU	RU	RU	RU	R	R	R	R	R	R	R	R	R	R
Default	0	1	1	0	0	1	0	X	X	X	0	0	0	0	1	0

Register: **Power management capabilities**

Type: Read/Update, Read-only

Offset: 46h

Default: 6XX2h

Table 3–16. Power Management Capabilities Register Description

BIT	FIELD NAME	TYPE	DESCRIPTION
15	PME_D3COLD	RU	PCI_PME support from D3 _{cold} . This bit can be set to 1 or cleared to 0 via bit 15 (PME_D3COLD) in the miscellaneous configuration register (offset F0h, see Section 3.22). The miscellaneous configuration register is loaded from ROM. When this bit is set to 1, it indicates that the TSB12LV23A device is capable of generating a PCI_PME wake event from D3 _{cold} . This bit state is dependent upon the TSB12LV23A V _{AUX} implementation and may be configured by using bit 15 (PME_D3COLD) in the miscellaneous configuration register (see Section 3.22).
14–11	PME_SUPPORT	RU	PCI_PME support. This 4-bit field indicates the power states from which the TSB12LV23A device may assert PCI_PME. This field returns a value of 1100b by default, indicating that PCI_PME may be asserted from the D3 _{hot} and D2 power states. Bit 13 may be modified by host software using bit 13 (PME_SUPPORT_D2) in the miscellaneous configuration register (offset F0h, see Section 3.22).
10	D2_SUPPORT	RU	D2 support. This bit can be set or cleared via bit 10 (D2_SUPPORT) in the miscellaneous configuration register (offset F0h, see Section 3.20). The miscellaneous configuration register is loaded from ROM. When this bit is set, it indicates that D2 support is present. When this bit is cleared, it indicates that D2 support is not present for backward compatibility with the TSB12LV22. For normal operation, this bit is set to 1.
9	D1_SUPPORT	R	D1 support. This bit returns a 0 when read, indicating that the TSB12LV23A device does not support the D1 power state.
8–6	AUX_CURRENT	R	Auxiliary current. This 3-bit field reports the 3.3-V _{AUX} auxiliary current requirements. When bit 15 (PME_D3COLD) is set to 1, this field returns 001b; otherwise, it returns 000b. 000b = Self-powered 001b = 55 mA (3.3 V _{AUX} maximum current required)
5	DSI	R	Device specific initialization. This bit returns 0 when read, indicating that the TSB12LV23A device does not require special initialization beyond the standard PCI configuration header before a generic class driver is able to use it.
4	RSVD	R	Reserved. This bit returns 0 when read.
3	PME_CLK	R	PCI_PME clock. This bit returns 0 when read, indicating that no host bus clock is required for the TSB12LV23A device to generate PCI_PME.
2–0	PM_VERSION	R	Power management version. This field returns 010b when read, indicating that the TSB12LV23A device is compatible with the registers described in the <i>PCI Bus Power Management Interface Specification</i> (Revision 1.1).

3.20 Power Management Control and Status Register

The power management control and status register implements the control and status of the PCI power management function. This register is not affected by the internally generated reset caused by the transition from the D3_{hot} to D0 state. See Table 3–17 for a complete description of the register contents.

Bit	15	14	13	12	11	10	9	8	7	6	5	4	3	2	1	0
Name	Power management control and status															
Type	RC	R	R	R	R	R	R	R/W	R	R	R	R	R	R	R/W	R/W
Default	0	0	0	0	0	0	0	0	0	0	0	0	0	0	0	0

Register: **Power management control and status**
 Type: Read/Clear, Read/Write, Read-only
 Offset: 48h
 Default: 0000h

Table 3–17. Power Management Control and Status Register Description

BIT	FIELD NAME	TYPE	DESCRIPTION
15	PME_STS	RC	This bit is set when the TSB12LV23A device would normally be asserting the $\overline{\text{PCI_PME}}$ signal, independent of the state of bit 8 (PME_ENB). This bit is cleared by a writeback of 1, and this also clears the PCI_PME signal driven by the TSB12LV23A device. Writing a 0 to this bit has no effect.
14–13	DATA_SCALE	R	This field returns 0s because the data register is not implemented.
12–9	DATA_SELECT	R	This field returns 0s because the data register is not implemented.
8	PME_ENB	R/W	When bit 8 = 1, $\overline{\text{PME}}$ assertion is enabled. When bit 8 = 0, $\overline{\text{PME}}$ assertion is disabled. This bit defaults to 0 if the function does not support $\overline{\text{PME}}$ generation from D3 _{cold} . If the function supports $\overline{\text{PME}}$ from D3 _{cold} , then this bit is sticky and must be explicitly cleared by the operating system each time it is initially loaded. Functions that do not support $\overline{\text{PME}}$ generation from any D-state (that is, bits 15–11 in the power management capabilities register (offset 46h, see Section 3.19) equal 00000b), may hardwire this bit to be read-only always returning a 0 when read by system software.
7–2	RSVD	R	Reserved. Bits 7–2 return 0s when read.
1–0	PWR_STATE	R/W	Power state. This 2-bit field is used to set the TSB12LV23A device power state and is encoded as follows: 00 = Current power state is D0 01 = Current power state is D1 10 = Current power state is D2 11 = Current power state is D3

3.21 Power Management Extension Register

The power management extension register provides extended power management features not applicable to the TSB12LV23A device, thus it is read-only and returns 0s when read. See Table 3–18 for a complete description of the register contents.

Bit	15	14	13	12	11	10	9	8	7	6	5	4	3	2	1	0
Name	Power management extension															
Type	R	R	R	R	R	R	R	R	R	R	R	R	R	R	R	R
Default	0	0	0	0	0	0	0	0	0	0	0	0	0	0	0	0

Register: **Power management extension**
 Type: Read-only
 Offset: 4Ah
 Default: 0000h

Table 3–18. Power Management Extension Register Description

BIT	FIELD NAME	TYPE	DESCRIPTION
15–0	RSVD	R	Reserved. Bits 15–0 return 0s when read.

3.22 Miscellaneous Configuration Register

The miscellaneous configuration register provides miscellaneous PCI-related configuration. See Table 3–19 for a complete description of the register contents.

Bit	31	30	29	28	27	26	25	24	23	22	21	20	19	18	17	16
Name	Miscellaneous configuration															
Type	R	R	R	R	R	R	R	R	R	R	R	R	R	R	R	R
Default	0	0	0	0	0	0	0	0	0	0	0	0	0	0	0	0
Bit	15	14	13	12	11	10	9	8	7	6	5	4	3	2	1	0
Name	Miscellaneous configuration															
Type	R/W	R	R/W	R	R	R/W	R	R	R	R	R	R/W	R/W	R/W	R/W	R/W
Default	0	0	1	0	0	1	0	0	0	0	0	0	0	0	0	0

Register: **Miscellaneous configuration**
 Type: Read/Write, Read-only
 Offset: F0h
 Default: 0000 2400h

Table 3–19. Miscellaneous Configuration Register Description

BIT	FIELD NAME	TYPE	DESCRIPTION
31–16	RSVD	R	Reserved. Bits 31–16 return 0s when read.
15	PME_D3COLD	R/W	$\overline{\text{PCI_PME}}$ support from D3 _{Cold} . This bit is used to program bit 15 (PME_D3COLD) in the power management capabilities register (offset 46h, see Section 3.19).
14	RSVD	R	Reserved. Bit 14 returns 0 when read.
13	PME_SUPPORT_D2	R/W	$\overline{\text{PCI_PME}}$ support. This bit is used to program bit 13 (PME_SUPPORT_D2) in the power management capabilities register (offset 46h, see Section 3.19). If wake from the D2 power state implemented in the TSB12LV23A device is not desired, then this bit may be cleared to indicate to power management software that wake-up from D2 is not supported.
12–11	RSVD	R	Reserved. Bits 12–11 return 0s when read.
10	D2_SUPPORT	R/W	D2 support. This bit is used to program bit 10 (D2_SUPPORT) in the power management capabilities register (offset 46h, see Section 3.19). If the D2 power state in the TSB12LV23A device is not desired, then this bit may be cleared to indicate to power management software that D2 is not supported.
9–5	RSVD	R	Reserved. Bits 9–5 return 0s when read.
4	DIS_TGT_ABT	R/W	This bit defaults to 0, which provides OHCI-Lynx™ compatible target abort signaling. When this bit is set to 1, it enables the no-target-abort mode, in which the TSB12LV23A device returns indeterminate data instead of signaling target abort. The link is divided into the PCI_CLK and SCLK domains. If software tries to access registers in the link that are not active because the SCLK is disabled, a target abort is issued by the link. On some systems this can cause a problem resulting in a fatal system error. Enabling this bit allows the link to respond to these types of requests by returning FFh. It is recommended that this bit be set to 1.
3	GP2IIC	R/W	When this bit is set to 1, the GPIO3 and GPIO2 signals are internally routed to the SCL and SDA, respectively. The GPIO3 and GPIO2 terminals are also placed in a high impedance state.
2	DISABLE_SCLKGATE	R/W	When this bit is set to 1, the internal SCLK runs identically with the chip input. This bit is a test feature only and should be cleared to 0 (all applications).
1	DISABLE_PCIGATE	R/W	When this bit is set, the internal PCI clock runs identically with the chip input. This bit is a test feature only and should be cleared to 0 (all applications).
0	KEEP_PCLK	R/W	When this bit is set to 1, the PCI clock is always kept running through the $\overline{\text{PCI_CLKRUN}}$ protocol. When this bit is cleared, the PCI clock may be stopped using $\overline{\text{PCI_CLKRUN}}$.

3.23 Link Enhancement Control Register

The link enhancement control register implements TI proprietary bits that are initialized by software or by a serial ROM, if present. After these bits are set, their functionality is enabled only if bit 22 (aPhyEnhanceEnable) in the host controller control register (OHCI offset 50h/54h, see Section 4.16) is set. See Table 3–20 for a complete description of the register contents.

Bit	31	30	29	28	27	26	25	24	23	22	21	20	19	18	17	16
Name	Link enhancement control															
Type	R	R	R	R	R	R	R	R	R	R	R	R	R	R	R	R
Default	0	0	0	0	0	0	0	0	0	0	0	0	0	0	0	0
Bit	15	14	13	12	11	10	9	8	7	6	5	4	3	2	1	0
Name	Link enhancement control															
Type	R	R	R/W	R/W	R	R	R/W	R/W	R/W	R	R	R	R	R/W	R/W	R
Default	0	0	0	1	0	0	0	0	0	0	0	0	0	0	0	0

Register: **Link enhancement control**
 Type: Read/Write, Read-only
 Offset: F4h
 Default: 0000 1000h

Table 3–20. Link Enhancement Control Register Description

BIT	FIELD NAME	TYPE	DESCRIPTION
31–14	RSVD	R	Reserved. Bits 31–14 return 0s when read.
13–12	atx_thresh	R/W	<p>This field sets the initial AT threshold value, which is used until the AT FIFO is underrun. When the TSB12LV23A device retries the packet, it uses a 2-Kbyte threshold resulting in a store-and-forward operation.</p> <ul style="list-style-type: none"> 00 = Threshold ~ 2K bytes resulting in a store-and-forward operation 01 = Threshold ~ 1.7K bytes (default) 10 = Threshold ~ 1K bytes 11 = Threshold ~ 512 bytes <p>These bits fine-tune the asynchronous transmit threshold. For most applications the 1.7-K threshold is optimal. Changing this value may increase or decrease the 1394 latency depending on the average PCI bus latency.</p> <p>Setting the AT threshold to 1.7K, 1K, or 512 bytes results in data being transmitted at these thresholds, or when an entire packet has been checked into the FIFO. If the packet to be transmitted is larger than the AT threshold, then the remaining data must be received before the AT FIFO is emptied; otherwise, an underrun condition will occur, resulting in a packet error at the receiving node. As a result, the link will then commence store-and-forward operation, that is, wait until it has the complete packet in the FIFO before retransmitting it on the second attempt, to ensure delivery.</p> <p>An AT threshold of 2K results in store-and-forward operation, which means that asynchronous data will not be transmitted until an end-of-packet token is received. Restated, setting the AT threshold to 2K results in only complete packets being transmitted.</p> <p>Note that this device will always use store-and-forward when the asynchronous transmit retries register (OHCI offset 08h, see Section 4.3) is cleared.</p>
11–10	RSVD	R	Reserved. Bits 11–10 return 0s when read.
9	enab_audio_ts	R/W	Enable audio/music CIP time stamp enhancement. When this bit is set, the enhancement is enabled for audio/music CIP transmit streams (FMT = 10h).
8	enab_dv_ts	R/W	Enable DV CIP time stamp enhancement. When this bit is set, the enhancement is enabled for DV CIP transmit streams (FMT = 00h).
7	enab_unfair	R/W	Enable asynchronous priority requests. OHCI-Lynx™ compatible. Setting this bit to 1 enables the link to respond to requests with priority arbitration. It is recommended that this bit be set to 1.
6	RSVD	R	This bit is not assigned in the TSB12LV23A follow-on products since this bit location loaded by the serial ROM from the enhancements field corresponds to bit 23 (programPhyEnable) in the host controller control register (OHCI offset 50h/54h, see Section 4.16).

Table 3–20. Link Enhancement Control Register Description (Continued)

BIT	FIELD NAME	TYPE	DESCRIPTION
5–3	RSVD	R	Reserved. Bits 5–3 return 0s when read.
2	enab_insert_idle	R/W	Enable insert idle. OHCI-Lynx™ compatible. When the PHY device has control of the PHY_CTL0–PHY_CTL1 control lines and PHY_DATA0–PHY_DATA7 data lines and the link requests control, the PHY device drives 11b on the PHY_CTL0–PHY_CTL1 lines. The link can then start driving these lines immediately. Setting this bit to 1 inserts an idle state, so the link waits one clock cycle before it starts driving the lines (turnaround time). It is recommended that this bit be set to 1.
1	enab_accel	R/W	Enable acceleration enhancements. OHCI-Lynx™ compatible. When set to 1, this bit notifies the PHY device that the link supports the IEEE 1394a-2000 acceleration enhancements, that is, ack-accelerated, fly-by concatenation, etc. It is recommended that this bit be set to 1.
0	RSVD	R	Reserved. Bit 0 returns 0 when read.

3.24 Subsystem Access Register

Write access to the subsystem access register updates the subsystem identification registers identically to OHCI-Lynx™. The system ID value written to this register may also be read back from this register. See Table 3–21 for a complete description of the register contents.

Bit	31	30	29	28	27	26	25	24	23	22	21	20	19	18	17	16
Name	Subsystem access															
Type	R/W	R/W	R/W	R/W	R/W	R/W	R/W	R/W	R/W	R/W	R/W	R/W	R/W	R/W	R/W	R/W
Default	0	0	0	0	0	0	0	0	0	0	0	0	0	0	0	0
Bit	15	14	13	12	11	10	9	8	7	6	5	4	3	2	1	0
Name	Subsystem access															
Type	R/W	R/W	R/W	R/W	R/W	R/W	R/W	R/W	R/W	R/W	R/W	R/W	R/W	R/W	R/W	R/W
Default	0	0	0	0	0	0	0	0	0	0	0	0	0	0	0	0

Register: **Subsystem access**
 Type: Read/Write
 Offset: F8h
 Default: 0000 0000h

Table 3–21. Subsystem Access Register Description

BIT	FIELD NAME	TYPE	DESCRIPTION
31–16	SUBDEV_ID	R/W	Subsystem device ID alias. This field indicates the subsystem device ID.
15–0	SUBVEN_ID	R/W	Subsystem vendor ID alias. This field indicates the subsystem vendor ID.

3.25 GPIO Control Register

The GPIO control register has the control and status bits for the GPIO2 and GPIO3 ports. See Table 3–22 for a complete description of the register contents.

Bit	31	30	29	28	27	26	25	24	23	22	21	20	19	18	17	16
Name	GPIO control															
Type	R/W	R	R/W	R/W	R	R	R	RWU	R/W	R	R/W	R/W	R	R	R	RWU
Default	0	0	0	0	0	0	0	0	0	0	0	0	0	0	0	0
Bit	15	14	13	12	11	10	9	8	7	6	5	4	3	2	1	0
Name	GPIO control															
Type	R	R	R	R	R	R	R	R	R	R	R	R	R	R	R	R
Default	0	0	0	0	0	0	0	0	0	0	0	0	0	0	0	0

Register: **GPIO control**
 Type: Read/Write/Update, Read/Write, Read-only
 Offset: FCh
 Default: 0000 0000h

Table 3–22. GPIO Control Register Description

BIT	FIELD NAME	TYPE	DESCRIPTION
31	INT_3EN	R/W	When this bit is set, a TSB12LV23A general-purpose interrupt event occurs on a level change of the GPIO3 input. This event may generate an interrupt, with mask and event status reported through the OHCI interrupt mask (OHCI offset 88h/8Ch, see Section 4.22) and interrupt event (OHCI offset 80h/84h, see Section 4.21) registers.
30	RSVD	R	Reserved. Bit 30 returns 0 when read.
29	GPIO_INV3	R/W	GPIO3 polarity invert. When this bit is set, the polarity of GPIO3 is inverted.
28	GPIO_ENB3	R/W	GPIO3 enable control. When this bit is set, the output is enabled. Otherwise, the output is high impedance.
27–25	RSVD	R	Reserved. Bits 27–25 return 0s when read.
24	GPIO_DATA3	RWU	GPIO3 data. Reads from this bit return the logical value of the input to GPIO3. Writes to this bit update the value to drive to GPIO3 when output is enabled.
23	INT_2EN	R/W	When this bit is set, a TSB12LV23A general-purpose interrupt event occurs on a level change of the GPIO3 input. This event may generate an interrupt, with mask and event status reported through the OHCI interrupt mask (OHCI offset 88h/8Ch, see Section 4.22) and interrupt event (OHCI offset 80h/84h, see Section 4.21) registers.
22	RSVD	R	Reserved. Bit 22 returns 0 when read.
21	GPIO_INV2	R/W	GPIO2 polarity invert. When this bit is set, the polarity of GPIO2 is inverted.
20	GPIO_ENB2	R/W	GPIO2 enable control. When this bit is set, the output is enabled. Otherwise, the output is high impedance.
19–17	RSVD	R	Reserved. Bits 19–17 return 0s when read.
16	GPIO_DATA2	RWU	GPIO2 data. Reads from this bit return the logical value of the input to GPIO2. Writes to this bit update the value to drive to GPIO2 when the output is enabled.
15–0	RSVD	R	Reserved. Bits 15–0 return 0s when read.

4 OHCI Registers

The OHCI registers defined by the *1394 Open Host Controller Interface Specification* are memory-mapped into a 2-Kbyte region of memory pointed to by the OHCI base address register at offset 10h in PCI configuration space (see Section 3.9). These registers are the primary interface for controlling the TSB12LV23A IEEE 1394 link function.

This section provides the register interface and bit descriptions. Several set/clear register pairs in this programming model are implemented to solve various issues with typical read-modify-write control registers. There are two addresses for a set/clear register: RegisterSet and RegisterClear. See Table 4–1 for an illustration. A 1 bit written to RegisterSet causes the corresponding bit in the set/clear register to be set; a 0 bit leaves the corresponding bit unaffected. A 1 bit written to RegisterClear causes the corresponding bit in the set/clear register to be cleared; a 0 bit leaves the corresponding bit in the set/clear register unaffected.

Typically, a read from either RegisterSet or RegisterClear returns the contents of the set or clear register, respectively. However, sometimes reading the RegisterClear provides a masked version of the set or clear register. The interrupt event register is an example of this behavior.

Table 4–1. OHCI Register Map

DMA CONTEXT	REGISTER NAME	ABBREVIATION	OFFSET	
—	OHCI version	Version	00h	
	GUID ROM	GUID_ROM	04h	
	Asynchronous transmit retries	ATRetries	08h	
	CSR data	CSRData	0Ch	
	CSR compare	CSRCompareData	10h	
	CSR control	CSRControl	14h	
	Configuration ROM header	ConfigROMhdr	18h	
	Bus identification	BusID	1Ch	
	Bus options	BusOptions	20h	
	GUID high	GUIDHi	24h	
	GUID low	GUIDLo	28h	
	Reserved	—	2Ch–30h	
	Configuration ROM mapping	ConfigROMmap	34h	
	Posted write address low	PostedWriteAddressLo	38h	
	Posted write address high	PostedWriteAddressHi	3Ch	
	Vendor ID	VendorID	40h	
	Reserved	—	44h–4Ch	
	Host controller control	HCControlSet		50h
		HCControlClr		54h
	Reserved	—	58h–5Ch	

Table 4–1. OHCI Register Map (Continued)

DMA CONTEXT	REGISTER NAME	ABBREVIATION	OFFSET
Self-ID	Reserved	—	60h
	Self-ID buffer	SelfIDBuffer	64h
	Self-ID count	SelfIDCount	68h
	Reserved	—	6Ch
—	Isochronous receive channel mask high	IRChannelMaskHiSet	70h
		IRChannelMaskHiClear	74h
	Isochronous receive channel mask low	IRChannelMaskLoSet	78h
		IRChannelMaskLoClear	7Ch
	Interrupt event	IntEventSet	80h
		IntEventClear	84h
	Interrupt mask	IntMaskSet	88h
		IntMaskClear	8Ch
	Isochronous transmit interrupt event	IsoXmitIntEventSet	90h
		IsoXmitIntEventClear	94h
	Isochronous transmit interrupt mask	IsoXmitIntMaskSet	98h
		IsoXmitIntMaskClear	9Ch
—	Isochronous receive interrupt event	IsoRecvIntEventSet	A0h
		IsoRecvIntEventClear	A4h
	Isochronous receive interrupt mask	IsoRecvIntMaskSet	A8h
		IsoRecvIntMaskClear	ACh
	Reserved		B0–D8h
	Fairness control	FairnessControl	DCh
	Link control	LinkControlSet	E0h
		LinkControlClear	E4h
	Node identification	NodeID	E8h
	PHY layer control	PhyControl	ECh
	Isochronous cycle timer	Isocyc timer	F0h
	Reserved		F4h–FCh
	Asynchronous request filter high	AsyncRequestFilterHiSet	100h
		AsyncRequestFilterHiClear	104h
	Asynchronous request filter low	AsyncRequestFilterLoSet	108h
		AsyncRequestFilterLoClear	10Ch
	Physical request filter high	PhysicalRequestFilterHiSet	110h
		PhysicalRequestFilterHiClear	114h
	Physical request filter low	PhysicalRequestFilterLoSet	118h
		PhysicalRequestFilterLoClear	11Ch
Physical upper bound	PhysicalUpperBound	120h	
Reserved	—	124h–17Ch	

Table 4–1. OHCI Register Map (Continued)

DMA CONTEXT	REGISTER NAME	ABBREVIATION	OFFSET
Asynchronous Request Transmit [ATRQ]	Asynchronous context control	ContextControlSet	180h
		ContextControlClear	184h
	Reserved	—	188h
	Asynchronous context command pointer	CommandPtr	18Ch
	Reserved	—	190h–19Ch
Asynchronous Response Transmit [ATRS]	Asynchronous context control	ContextControlSet	1A0h
		ContextControlClear	1A4h
	Reserved	—	1A8h
	Asynchronous context command pointer	CommandPtr	1ACh
	Reserved	—	1B0h–1BCh
Asynchronous Request Receive [ARRQ]	Asynchronous context control	ContextControlSet	1C0h
		ContextControlClear	1C4h
	Reserved	—	1C8h
	Command pointer	CommandPtr	1CCh
	Reserved	—	1D0h–1DCh
Asynchronous Response Receive [ARRS]	Asynchronous context control	ContextControlSet	1E0h
		ContextControlClear	1E4h
	Reserved	—	1E8h
	Command pointer	CommandPtr	1ECh
	Reserved	—	1F0h–1FCh
Isochronous Transmit Context n n = 0, 1, 2, 3, ..., 7	Isochronous transmit context control	ContextControlSet	200h + 16*n
		ContextControlClear	204h + 16*n
	Reserved	—	208h + 16*n
	Isochronous transmit context command pointer	CommandPtr	20Ch + 16*n
	Reserved	—	280h – 3FCh
Isochronous Receive Context n n = 0, 1, 2, 3	Isochronous receive context control	ContextControlSet	400h + 32*n
		ContextControlClear	404h + 32*n
	Reserved	—	408h + 32*n
	Isochronous receiver context command pointer	CommandPtr	40Ch + 32*n
	Context match	ContextMatch	410h + 32*n
Isochronous Receive Digital Video Enhancement	Context control	Context control set	A88h
		Context control clear	A8Ch

4.1 OHCI Version Register

This register indicates the OHCI version support, and whether or not a serial ROM is present. See Table 4–2 for a complete description of the register contents.

Bit	31	30	29	28	27	26	25	24	23	22	21	20	19	18	17	16
Name	OHCI version															
Type	R	R	R	R	R	R	R	R	R	R	R	R	R	R	R	R
Default	0	0	0	0	0	0	0	X	0	0	0	0	0	0	0	1
Bit	15	14	13	12	11	10	9	8	7	6	5	4	3	2	1	0
Name	OHCI version															
Type	R	R	R	R	R	R	R	R	R	R	R	R	R	R	R	R
Default	0	0	0	0	0	0	0	0	0	0	0	0	0	0	0	0

Register: **OHCI version**
 Type: Read-only
 Offset: 00h
 Default: 0X01 0000h

Table 4–2. OHCI Version Register Description

BIT	FIELD NAME	TYPE	DESCRIPTION
31–25	RSVD	R	Reserved. Bits 31–25 return 0s when read.
24	GUID_ROM	R	The TSB12LV23A device sets this bit if the serial ROM is detected. If the serial ROM is present, then the Bus_Info_Block is automatically loaded on hardware reset.
23–16	version	R	Major version of the OHCI. The TSB12LV23A device is compliant with the <i>1394 Open Host Controller Interface Specification</i> ; thus, this field reads 01h.
15–8	RSVD	R	Reserved. Bits 15–8 return 0s when read.
7–0	revision	R	Minor version of the OHCI. The TSB12LV23A device is compliant with the <i>1394 Open Host Controller Interface Specification</i> ; thus, this field reads 00h.

4.2 GUID ROM Register

The GUID ROM register is used to access the serial ROM, and is only applicable if bit 24 (GUID_ROM) in the OHCI version register (OHCI offset 00h, see Section 4.1) is set. See Table 4–3 for a complete description of the register contents.

Bit	31	30	29	28	27	26	25	24	23	22	21	20	19	18	17	16
Name	GUID ROM															
Type	RSU	R	R	R	R	R	RSU	R	RU	RU	RU	RU	RU	RU	RU	RU
Default	0	0	0	0	0	0	0	0	X	X	X	X	X	X	X	X
Bit	15	14	13	12	11	10	9	8	7	6	5	4	3	2	1	0
Name	GUID ROM															
Type	R	R	R	R	R	R	R	R	R	R	R	R	R	R	R	R
Default	0	0	0	0	0	0	0	0	0	0	0	0	0	0	0	0

Register: **GUID ROM**
 Type: Read/Set/Update, Read/Update, Read-only
 Offset: 04h
 Default: 00XX 0000h

Table 4–3. GUID ROM Register Description

BIT	FIELD NAME	TYPE	DESCRIPTION
31	addrReset	RSU	Software sets this bit to reset the GUID ROM address to 0. When the TSB12LV23A device completes the reset, it clears this bit. The TSB12LV23A device does not automatically fill bits 23–16 (rdData field) with the 0 th byte.
30–26	RSVD	R	Reserved. Bits 30–26 return 0s when read.
25	rdStart	RSU	A read of the currently addressed byte is started when this bit is set. This bit is automatically cleared when the TSB12LV23A device completes the read of the currently addressed GUID ROM byte.
24	RSVD	R	Reserved. Bit 24 returns 0 when read.
23–16	rdData	RU	This field represents the data read from the GUID ROM.
15–0	RSVD	R	Reserved. Bits 15–0 return 0s when read.

4.3 Asynchronous Transmit Retries Register

The asynchronous transmit retries register indicates the number of times the TSB12LV23A device attempts a retry for asynchronous DMA request transmit and for asynchronous physical and DMA response transmit. See Table 4–4 for a complete description of the register contents.

Bit	31	30	29	28	27	26	25	24	23	22	21	20	19	18	17	16
Name	Asynchronous transmit retries															
Type	R	R	R	R	R	R	R	R	R	R	R	R	R	R	R	R
Default	0	0	0	0	0	0	0	0	0	0	0	0	0	0	0	0
Bit	15	14	13	12	11	10	9	8	7	6	5	4	3	2	1	0
Name	Asynchronous transmit retries															
Type	R	R	R	R	R/W	R/W	R/W	R/W	R/W	R/W	R/W	R/W	R/W	R/W	R/W	R/W
Default	0	0	0	0	0	0	0	0	0	0	0	0	0	0	0	0

Register: **Asynchronous transmit retries**
 Type: Read/Write, Read-only
 Offset: 08h
 Default: 0000 0000h

Table 4–4. Asynchronous Transmit Retries Register Description

BIT	FIELD NAME	TYPE	DESCRIPTION
31–29	secondLimit	R	The second limit field returns 0s when read because outbound dual-phase retry is not implemented.
28–16	cycleLimit	R	The cycle limit field returns 0s when read because outbound dual-phase retry is not implemented.
15–12	RSVD	R	Reserved. Bits 15–12 return 0s when read.
11–8	maxPhysRespRetries	R/W	This field tells the physical response unit how many times to attempt to retry the transmit operation for the response packet when a busy acknowledge or ack_data_error is received from the target node.
7–4	maxATRespRetries	R/W	This field tells the asynchronous transmit response unit how many times to attempt to retry the transmit operation for the response packet when a busy acknowledge or ack_data_error is received from the target node.
3–0	maxATReqRetries	R/W	This field tells the asynchronous transmit DMA request unit how many times to attempt to retry the transmit operation for the response packet when a busy acknowledge or ack_data_error is received from the target node.

4.4 CSR Data Register

The CSR data register is used to access the bus management CSR registers from the host through compare-swap operations. This register contains the data to be stored in a CSR if the compare is successful.

Bit	31	30	29	28	27	26	25	24	23	22	21	20	19	18	17	16
Name	CSR data															
Type	R	R	R	R	R	R	R	R	R	R	R	R	R	R	R	R
Default	X	X	X	X	X	X	X	X	X	X	X	X	X	X	X	X
Bit	15	14	13	12	11	10	9	8	7	6	5	4	3	2	1	0
Name	CSR data															
Type	R	R	R	R	R	R	R	R	R	R	R	R	R	R	R	R
Default	X	X	X	X	X	X	X	X	X	X	X	X	X	X	X	X

Register: **CSR data**
 Type: Read-only
 Offset: 0Ch
 Default: XXXX XXXXh

4.5 CSR Compare Register

The CSR compare register is used to access the bus management CSR registers from the host through compare-swap operations. This register contains the data to be compared with the existing value of the CSR resource.

Bit	31	30	29	28	27	26	25	24	23	22	21	20	19	18	17	16
Name	CSR compare															
Type	R	R	R	R	R	R	R	R	R	R	R	R	R	R	R	R
Default	X	X	X	X	X	X	X	X	X	X	X	X	X	X	X	X
Bit	15	14	13	12	11	10	9	8	7	6	5	4	3	2	1	0
Name	CSR compare															
Type	R	R	R	R	R	R	R	R	R	R	R	R	R	R	R	R
Default	X	X	X	X	X	X	X	X	X	X	X	X	X	X	X	X

Register: **CSR compare**
 Type: Read-only
 Offset: 10h
 Default: XXXX XXXXh

4.6 CSR Control Register

The CSR control register is used to access the bus management CSR registers from the host through compare-swap operations. This register is used to control the compare-swap operation and to select the CSR resource. See Table 4–5 for a complete description of the register contents.

Bit	31	30	29	28	27	26	25	24	23	22	21	20	19	18	17	16
Name	CSR control															
Type	RU	R	R	R	R	R	R	R	R	R	R	R	R	R	R	R
Default	1	0	0	0	0	0	0	0	0	0	0	0	0	0	0	0
Bit	15	14	13	12	11	10	9	8	7	6	5	4	3	2	1	0
Name	CSR control															
Type	R	R	R	R	R	R	R	R	R	R	R	R	R	R	R/W	R/W
Default	0	0	0	0	0	0	0	0	0	0	0	0	0	0	X	X

Register: **CSR control**
 Type: Read/Update, Read/Write, Read-only
 Offset: 14h
 Default: 8000 000Xh

Table 4–5. CSR Control Register Description

BIT	FIELD NAME	TYPE	DESCRIPTION
31	csrDone	RU	This bit is set by the TSB12LV23A device when a compare-swap operation is complete. It is cleared whenever this register is written.
30–2	RSVD	R	Reserved. Bits 30–2 return 0s when read.
1–0	csrSel	R/W	This field selects the CSR resource as follows: 00 = BUS_MANAGER_ID 01 = BANDWIDTH_AVAILABLE 10 = CHANNELS_AVAILABLE_HI 11 = CHANNELS_AVAILABLE_LO

4.7 Configuration ROM Header Register

The configuration ROM header register externally maps to the first quadlet of the 1394 configuration ROM, offset FFFF F000 0400h. See Table 4–6 for a complete description of the register contents.

Bit	31	30	29	28	27	26	25	24	23	22	21	20	19	18	17	16
Name	Configuration ROM header															
Type	R/W	R/W	R/W	R/W	R/W	R/W	R/W	R/W	R/W	R/W	R/W	R/W	R/W	R/W	R/W	R/W
Default	0	0	0	0	0	0	0	0	0	0	0	0	0	0	0	0
Bit	15	14	13	12	11	10	9	8	7	6	5	4	3	2	1	0
Name	Configuration ROM header															
Type	R/W	R/W	R/W	R/W	R/W	R/W	R/W	R/W	R/W	R/W	R/W	R/W	R/W	R/W	R/W	R/W
Default	X	X	X	X	X	X	X	X	X	X	X	X	X	X	X	X

Register: **Configuration ROM header**
 Type: Read/Write
 Offset: 18h
 Default: 0000 XXXXh

Table 4–6. Configuration ROM Header Register Description

BIT	FIELD NAME	TYPE	DESCRIPTION
31–24	info_length	R/W	IEEE 1394 bus management field. Must be valid when bit 17 (linkEnable) of the host controller control register (OHCI offset 50h/54h, see Section 4.16) is set.
23–16	crc_length	R/W	IEEE 1394 bus management field. Must be valid when bit 17 (linkEnable) of the host controller control register (OHCI offset 50h/54h, see Section 4.16) is set.
15–0	rom_crc_value	R/W	IEEE 1394 bus management field. Must be valid at any time bit 17 (linkEnable) of the host controller control register (OHCI offset 50h/54h, see Section 4.16) is set. The reset value is undefined if no serial ROM is present. If a serial ROM is present, then this field is loaded from the serial ROM.

4.8 Bus Identification Register

The bus identification register externally maps to the first quadlet in the Bus_Info_Block, and contains the constant 3133 3934h, which is the ASCII value of 1394.

Bit	31	30	29	28	27	26	25	24	23	22	21	20	19	18	17	16
Name	Bus identification															
Type	R	R	R	R	R	R	R	R	R	R	R	R	R	R	R	R
Default	0	0	1	1	0	0	0	1	0	0	1	1	0	0	1	1
Bit	15	14	13	12	11	10	9	8	7	6	5	4	3	2	1	0
Name	Bus identification															
Type	R	R	R	R	R	R	R	R	R	R	R	R	R	R	R	R
Default	0	0	1	1	1	0	0	1	0	0	1	1	0	1	0	0

Register: **Bus identification**
 Type: Read-only
 Offset: 1Ch
 Default: 3133 3934h

4.9 Bus Options Register

The bus options register externally maps to the second quadlet of the Bus_Info_Block. See Table 4–7 for a complete description of the register contents.

Bit	31	30	29	28	27	26	25	24	23	22	21	20	19	18	17	16
Name	Bus options															
Type	R/W	R/W	R/W	R/W	R/W	R	R	R	R/W	R/W	R/W	R/W	R/W	R/W	R/W	R/W
Default	X	X	X	X	0	0	0	0	X	X	X	X	X	X	X	X
Bit	15	14	13	12	11	10	9	8	7	6	5	4	3	2	1	0
Name	Bus options															
Type	R/W	R/W	R/W	R/W	R	R	R	R	R/W	R/W	R	R	R	R	R	R
Default	1	0	1	0	0	0	0	0	X	X	0	0	0	0	1	0

Register: **Bus options**
 Type: Read/Write, Read-only
 Offset: 20h
 Default: X0XX A0X2h

Table 4–7. Bus Options Register Description

BIT	FIELD NAME	TYPE	DESCRIPTION
31	irmc	R/W	Isochronous resource manager capable. IEEE 1394 bus management field. Must be valid when bit 17 (linkEnable) of the host controller control register (OHCI offset 50h/54h, see Section 4.16) is set.
30	cmc	R/W	Cycle master capable. IEEE 1394 bus management field. Must be valid when bit 17 (linkEnable) of the host controller control register (OHCI offset 50h/54h, see Section 4.16) is set.
29	isc	R/W	Isochronous support capable. IEEE 1394 bus management field. Must be valid when bit 17 (linkEnable) of the host controller control register (OHCI offset 50h/54h, see Section 4.16) is set.
28	bmc	R/W	Bus manager capable. IEEE 1394 bus management field. Must be valid when bit 17 (linkEnable) of the host controller control register (OHCI offset 50h/54h, see Section 4.16) is set.
27	pmc	R/W	Power management capable. When set, this indicates that the node is power management capable. Must be valid when bit 17 (linkEnable) of the host controller control register (OHCI offset 50h/54h, see Section 4.16) is set.
26–24	RSVD	R	Reserved. Bits 26–24 return 0s when read.
23–16	cyc_clk_acc	R/W	Cycle master clock accuracy, in parts per million. IEEE 1394 bus management field. Must be valid when bit 17 (linkEnable) of the host controller control register (OHCI offset 50h/54h, see Section 4.16) is set.
15–12	max_rec	R/W	Maximum request. IEEE 1394 bus management field. Hardware initializes this field to indicate the maximum number of bytes in a block request packet that is supported by the implementation. This value, max_rec_bytes, must be 512 or greater and is calculated by $2^{(\text{max_rec} + 1)}$. Software may change this field; however, this field must be valid at any time bit 17 (linkEnable) of the host controller control register (OHCI offset 50h/54h, see Section 4.16) is set. A received block write request packet with a length greater than max_rec_bytes may generate an ack_type_error. This field is not affected by a soft reset, and defaults to a value indicating 2048 bytes on a hard reset.
11–8	RSVD	R	Reserved. Bits 11–8 return 0s when read.
7–6	g	R/W	Generation counter. This field is incremented if any portion of the configuration ROM has been incremented since the prior bus reset.
5–3	RSVD	R	Reserved. Bits 5–3 return 0s when read.
2–0	Lnk_spd	R	Link speed. This field returns 010, indicating that the link speeds of 100, 200, and 400 Mbits/s are supported.

4.10 GUID High Register

The GUID high register represents the upper quadlet in a 64-bit global unique ID (GUID) which maps to the third quadlet in the Bus_Info_Block. This register contains node_vendor_ID and chip_ID_hi fields. This register initializes to 0s on a hardware reset, which is an illegal GUID value. If a serial ROM is detected, then the contents of this register are loaded through the serial ROM interface after a PCI_RST. At that point, the contents of this register cannot be changed. If no serial ROM is detected, then the contents of this register are loaded by the BIOS after a PCI_RST. At that point, the contents of this register cannot be changed.

Bit	31	30	29	28	27	26	25	24	23	22	21	20	19	18	17	16
Name	GUID high															
Type	R	R	R	R	R	R	R	R	R	R	R	R	R	R	R	R
Default	0	0	0	0	0	0	0	0	0	0	0	0	0	0	0	0
Bit	15	14	13	12	11	10	9	8	7	6	5	4	3	2	1	0
Name	GUID high															
Type	R	R	R	R	R	R	R	R	R	R	R	R	R	R	R	R
Default	0	0	0	0	0	0	0	0	0	0	0	0	0	0	0	0

Register: **GUID high**
 Type: Read-only
 Offset: 24h
 Default: 0000 0000h

4.11 GUID Low Register

The GUID low register represents the lower quadlet in a 64-bit global unique ID (GUID) which maps to chip_ID_lo in the Bus_Info_Block. This register initializes to 0s on a hardware reset and behaves identically to the GUID high register (OHCI offset 24h, see Section 4.10).

Bit	31	30	29	28	27	26	25	24	23	22	21	20	19	18	17	16
Name	GUID low															
Type	R	R	R	R	R	R	R	R	R	R	R	R	R	R	R	R
Default	0	0	0	0	0	0	0	0	0	0	0	0	0	0	0	0
Bit	15	14	13	12	11	10	9	8	7	6	5	4	3	2	1	0
Name	GUID low															
Type	R	R	R	R	R	R	R	R	R	R	R	R	R	R	R	R
Default	0	0	0	0	0	0	0	0	0	0	0	0	0	0	0	0

Register: **GUID low**
 Type: Read-only
 Offset: 28h
 Default: 0000 0000h

4.12 Configuration ROM Mapping Register

The configuration ROM mapping register contains the start address within system memory that maps to the start address of 1394 configuration ROM for this node. See Table 4–8 for a complete description of the register contents.

Bit	31	30	29	28	27	26	25	24	23	22	21	20	19	18	17	16
Name	Configuration ROM mapping															
Type	R/W	R/W	R/W	R/W	R/W	R/W	R/W	R/W	R/W	R/W	R/W	R/W	R/W	R/W	R/W	R/W
Default	0	0	0	0	0	0	0	0	0	0	0	0	0	0	0	0
Bit	15	14	13	12	11	10	9	8	7	6	5	4	3	2	1	0
Name	Configuration ROM mapping															
Type	R/W	R/W	R/W	R/W	R/W	R/W	R	R	R	R	R	R	R	R	R	R
Default	0	0	0	0	0	0	0	0	0	0	0	0	0	0	0	0

Register: **Configuration ROM mapping**
 Type: Read/Write, Read-only
 Offset: 34h
 Default: 0000 0000h

Table 4–8. Configuration ROM Mapping Register Description

BIT	FIELD NAME	TYPE	DESCRIPTION
31–10	configROMAddr	R/W	If a quadlet read request to 1394 offset FFFF F000 0400h through offset FFFF F000 07FFh is received, then the low order 10 bits of the offset are added to this register to determine the host memory address of the read request.
9–0	RSVD	R	Reserved. Bits 9–0 return 0s when read.

4.13 Posted Write Address Low Register

The posted write address low register is used to communicate error information if a write request is posted and an error occurs while writing the posted data packet. This register contains the lower 32 bits of the 1394 destination offset of the write request that failed.

Bit	31	30	29	28	27	26	25	24	23	22	21	20	19	18	17	16
Name	Posted write address low															
Type	RU	RU	RU	RU	RU	RU	RU	RU	RU	RU	RU	RU	RU	RU	RU	RU
Default	X	X	X	X	X	X	X	X	X	X	X	X	X	X	X	X
Bit	15	14	13	12	11	10	9	8	7	6	5	4	3	2	1	0
Name	Posted write address low															
Type	RU	RU	RU	RU	RU	RU	RU	RU	RU	RU	RU	RU	RU	RU	RU	RU
Default	X	X	X	X	X	X	X	X	X	X	X	X	X	X	X	X

Register: **Posted write address low**
 Type: Read/Update
 Offset: 38h
 Default: XXXX XXXXh

4.14 Posted Write Address High Register

The posted write address high register is used to communicate error information if a write request is posted and an error occurs while writing the posted data packet. See Table 4–9 for a complete description of the register contents.

Bit	31	30	29	28	27	26	25	24	23	22	21	20	19	18	17	16
Name	Posted write address high															
Type	RU	RU	RU	RU	RU	RU	RU	RU	RU	RU	RU	RU	RU	RU	RU	RU
Default	X	X	X	X	X	X	X	X	X	X	X	X	X	X	X	X
Bit	15	14	13	12	11	10	9	8	7	6	5	4	3	2	1	0
Name	Posted write address high															
Type	RU	RU	RU	RU	RU	RU	RU	RU	RU	RU	RU	RU	RU	RU	RU	RU
Default	X	X	X	X	X	X	X	X	X	X	X	X	X	X	X	X

Register: **Posted write address high**
 Type: Read/Update
 Offset: 3Ch
 Default: XXXX XXXXh

Table 4–9. Posted Write Address High Register Description

BIT	FIELD NAME	TYPE	DESCRIPTION
31–16	sourceID	RU	This field is the 10-bit bus number (bits 31–22) and 6-bit node number (bits 21–16) of the node that issued the write request that failed.
15–0	offsetHi	RU	The upper 16 bits of the 1394 destination offset of the write request that failed.

4.15 Vendor ID Register

The vendor ID register holds the company ID of an organization that specifies any vendor-unique registers. The TSB12LV23A device does not implement Texas Instruments unique behavior with regards to OHCI. Thus, this register is read-only and returns 0s when read.

Bit	31	30	29	28	27	26	25	24	23	22	21	20	19	18	17	16
Name	Vendor ID															
Type	R	R	R	R	R	R	R	R	R	R	R	R	R	R	R	R
Default	0	0	0	0	0	0	0	0	0	0	0	0	0	0	0	0
Bit	15	14	13	12	11	10	9	8	7	6	5	4	3	2	1	0
Name	Vendor ID															
Type	R	R	R	R	R	R	R	R	R	R	R	R	R	R	R	R
Default	0	0	0	0	0	0	0	0	0	0	0	0	0	0	0	0

Register: **Vendor ID**
 Type: Read-only
 Offset: 40h
 Default: 0000 0000h

4.16 Host Controller Control Register

The host controller control set/clear register pair provides flags for controlling the TSB12LV23A device. See Table 4–10 for a complete description of the register contents.

Bit	31	30	29	28	27	26	25	24	23	22	21	20	19	18	17	16
Name	Host controller control															
Type	R	RSC	R	R	R	R	R	R	RC	RSC	R	R	RSC	RSC	RSC	RSCU
Default	0	X	0	0	0	0	0	0	0	0	0	0	0	X	0	0
Bit	15	14	13	12	11	10	9	8	7	6	5	4	3	2	1	0
Name	Host controller control															
Type	R	R	R	R	R	R	R	R	R	R	R	R	R	R	R	R
Default	0	0	0	0	0	0	0	0	0	0	0	0	0	0	0	0

Register: **Host controller control**
 Type: Read/Set/Clear/Update, Read/Set/Clear, Read/Clear, Read-only
 Offset: 50h set register
 54h clear register
 Default: X00X 0000h

Table 4–10. Host Controller Control Register Description

BIT	FIELD NAME	TYPE	DESCRIPTION
31	RSVD	R	Reserved. Bit 31 returns 0 when read.
30	noByteSwapData	RSC	This bit is used to control whether physical accesses to locations outside the TSB12LV23A device itself as well as any other DMA data accesses should be swapped.
29–24	RSVD	R	Reserved. Bits 29–24 return 0s when read.
23	programPhyEnable	RC	This bit informs upper level software that lower level software has consistently configured the IEEE 1394a-2000 enhancements in the link and PHY device. When this bit is 1, generic software such as the OHCI driver is responsible for configuring IEEE 1394a-2000 enhancements in the PHY device and bit 22 (aPhyEnhanceEnable) in the TSB12LV23A device. When this bit is 0, the generic software may not modify the IEEE 1394a-2000 enhancements in the TSB12LV23A or PHY device and cannot interpret the setting of bit 22 (aPhyEnhanceEnable). This bit is initialized from serial ROM.
22	aPhyEnhanceEnable	RSC	When bits 23 (programPhyEnable) and 17 (linkEnable) are 1, the OHCI driver can set this bit to use all IEEE 1394a-2000 enhancements. When bit 23 (programPhyEnable) is set to 0, the software does not change PHY enhancements or this bit.
21–20	RSVD	R	Reserved. Bits 21–20 return 0s when read.
19	LPS	RSC	This bit is used to control the link power status. Software must set this bit to 1 to permit link-PHY communication. A 0 prevents link-PHY communication. The OHCI-link is divided into two clock domains (PCI_CLK and PHY_SCLK). If software tries to access any register in the PHY_SCLK domain while the PHY_SCLK is disabled, then a target abort issued by the link. This problem can be avoided by setting bit 4 (DIS_TGT_ABT) to 1 in the miscellaneous configuration register (offset F0h, see Section 3.22). This allows the link to respond to these types of request by returning all F's (hex). OHCI registers at offsets DCh–F0h and 100h–11Ch are in the SCLK domain. After setting LPS software should wait at least 10 ms before attempting to access any of the OHCI registers. This gives the PHY_SCLK time to stabilize.
18	postedWriteEnable	RSC	This bit is used to enable (1) or disable (0) posted writes. Software should change this bit only when bit 17 (linkEnable) is 0.
17	linkEnable	RSC	This bit is cleared to 0 by either a hardware or software reset. Software must set this bit to 1 when the system is ready to begin operation and then force a bus reset. This bit is necessary to keep other nodes from sending transactions before the local system is ready. When this bit is cleared, the TSB12LV23A device is logically and immediately disconnected from the 1394 bus, no packets are received or processed nor are packets transmitted.

Table 4–10. Host Controller Control Register Description (Continued)

BIT	FIELD NAME	TYPE	DESCRIPTION
16	softReset	RSCU	When this bit is set, all TSB12LV23A states are reset, all FIFOs are flushed, and all OHCI registers are set to their hardware reset values unless otherwise specified. PCI registers are not affected by this bit. This bit remains set while the soft reset is in progress and reverts back to 0 when the reset has completed.
15–0	RSVD	R	Reserved. Bits 15–0 return 0s when read.

4.17 Self-ID Buffer Pointer Register

The self-ID buffer pointer register points to the 2-Kbyte-aligned base address of the buffer in host memory where the self-ID packets are stored during bus initialization. Bits 31–11 are read/write accessible. Bits 10–0 are reserved and return 0s when read.

Bit	31	30	29	28	27	26	25	24	23	22	21	20	19	18	17	16
Name	Self-ID buffer pointer															
Type	R/W	R/W	R/W	R/W	R/W	R/W	R/W	R/W	R/W	R/W	R/W	R/W	R/W	R/W	R/W	R/W
Default	X	X	X	X	X	X	X	X	X	X	X	X	X	X	X	X
Bit	15	14	13	12	11	10	9	8	7	6	5	4	3	2	1	0
Name	Self-ID buffer pointer															
Type	R/W	R/W	R/W	R/W	R/W	R	R	R	R	R	R	R	R	R	R	R
Default	X	X	X	X	X	0	0	0	0	0	0	0	0	0	0	0

Register: **Self-ID buffer pointer**
 Type: Read/Write, Read-only
 Offset: 64h
 Default: XXXX XX00h

4.18 Self-ID Count Register

The self-ID count register keeps a count of the number of times the bus self-ID process has occurred, flags self-ID packet errors, and keeps a count of the self-ID data in the self-ID buffer. See Table 4–11 for a complete description of the register contents.

Bit	31	30	29	28	27	26	25	24	23	22	21	20	19	18	17	16
Name	Self-ID count															
Type	RU	R	R	R	R	R	R	R	RU	RU	RU	RU	RU	RU	RU	RU
Default	X	0	0	0	0	0	0	0	X	X	X	X	X	X	X	X
Bit	15	14	13	12	11	10	9	8	7	6	5	4	3	2	1	0
Name	Self-ID count															
Type	R	R	R	R	R	RU	RU	RU	RU	RU	RU	RU	RU	RU	R	R
Default	0	0	0	0	0	0	0	0	0	0	0	0	0	0	0	0

Register: **Self-ID count**
 Type: Read/Update, Read-only
 Offset: 68h
 Default: X0XX 0000h

Table 4–11. Self-ID Count Register Description

BIT	FIELD NAME	TYPE	DESCRIPTION
31	selfIDError	RU	When this bit is 1, an error was detected during the most recent self-ID packet reception. The contents of the self-ID buffer are undefined. This bit is cleared after a self-ID reception in which no errors are detected. Note that an error can be a hardware error or a host bus write error.
30–24	RSVD	R	Reserved. Bits 30–24 return 0s when read.
23–16	selfIDGeneration	RU	The value in this field increments each time a bus reset is detected. This field rolls over to 0 after reaching 255.
15–11	RSVD	R	Reserved. Bits 15–11 return 0s when read.
10–2	selfIDSize	RU	This field indicates the number of quadlets that have been written into the self-ID buffer for the current bits 23–16 (selfIDGeneration field). This includes the header quadlet and the self-ID data. This field is cleared to 0 when the self-ID reception begins.
1–0	RSVD	R	Reserved. Bits 1–0 return 0s when read.

4.19 Isochronous Receive Channel Mask High Register

The isochronous receive channel mask high set/clear register is used to enable packet receives from the upper 32 isochronous data channels. A read from either the set register or clear register returns the content of the isochronous receive channel mask high register. See Table 4–12 for a complete description of the register contents.

Bit	31	30	29	28	27	26	25	24	23	22	21	20	19	18	17	16
Name	Isochronous receive channel mask high															
Type	RSC	RSC	RSC	RSC	RSC	RSC	RSC	RSC	RSC	RSC	RSC	RSC	RSC	RSC	RSC	RSC
Default	X	X	X	X	X	X	X	X	X	X	X	X	X	X	X	X
Bit	15	14	13	12	11	10	9	8	7	6	5	4	3	2	1	0
Name	Isochronous receive channel mask high															
Type	RSC	RSC	RSC	RSC	RSC	RSC	RSC	RSC	RSC	RSC	RSC	RSC	RSC	RSC	RSC	RSC
Default	X	X	X	X	X	X	X	X	X	X	X	X	X	X	X	X

Register: **Isochronous receive channel mask high**
 Type: Read/Set/Clear
 Offset: 70h set register
 74h clear register
 Default: XXXX XXXXh

Table 4–12. Isochronous Receive Channel Mask High Register Description

BIT	FIELD NAME	TYPE	DESCRIPTION
31	isoChannel63	RSC	When this bit is set, the TSB12LV23A device is enabled to receive from iso channel number 63.
30	isoChannel62	RSC	When this bit is set, the TSB12LV23A device is enabled to receive from iso channel number 62.
29	isoChannel61	RSC	When this bit is set, the TSB12LV23A device is enabled to receive from iso channel number 61.
28	isoChannel60	RSC	When this bit is set, the TSB12LV23A device is enabled to receive from iso channel number 60.
27	isoChannel59	RSC	When this bit is set, the TSB12LV23A device is enabled to receive from iso channel number 59.
26	isoChannel58	RSC	When this bit is set, the TSB12LV23A device is enabled to receive from iso channel number 58.
25	isoChannel57	RSC	When this bit is set, the TSB12LV23A device is enabled to receive from iso channel number 57.
24	isoChannel56	RSC	When this bit is set, the TSB12LV23A device is enabled to receive from iso channel number 56.
23	isoChannel55	RSC	When this bit is set, the TSB12LV23A device is enabled to receive from iso channel number 55.
22	isoChannel54	RSC	When this bit is set, the TSB12LV23A device is enabled to receive from iso channel number 54.
21	isoChannel53	RSC	When this bit is set, the TSB12LV23A device is enabled to receive from iso channel number 53.
20	isoChannel52	RSC	When this bit is set, the TSB12LV23A device is enabled to receive from iso channel number 52.
19	isoChannel51	RSC	When this bit is set, the TSB12LV23A device is enabled to receive from iso channel number 51.
18	isoChannel50	RSC	When this bit is set, the TSB12LV23A device is enabled to receive from iso channel number 50.
17	isoChannel49	RSC	When this bit is set, the TSB12LV23A device is enabled to receive from iso channel number 49.
16	isoChannel48	RSC	When this bit is set, the TSB12LV23A device is enabled to receive from iso channel number 48.
15	isoChannel47	RSC	When this bit is set, the TSB12LV23A device is enabled to receive from iso channel number 47.
14	isoChannel46	RSC	When this bit is set, the TSB12LV23A device is enabled to receive from iso channel number 46.
13	isoChannel45	RSC	When this bit is set, the TSB12LV23A device is enabled to receive from iso channel number 45.
12	isoChannel44	RSC	When this bit is set, the TSB12LV23A device is enabled to receive from iso channel number 44.
11	isoChannel43	RSC	When this bit is set, the TSB12LV23A device is enabled to receive from iso channel number 43.
10	isoChannel42	RSC	When this bit is set, the TSB12LV23A device is enabled to receive from iso channel number 42.
9	isoChannel41	RSC	When this bit is set, the TSB12LV23A device is enabled to receive from iso channel number 41.
8	isoChannel40	RSC	When this bit is set, the TSB12LV23A device is enabled to receive from iso channel number 40.
7	isoChannel39	RSC	When this bit is set, the TSB12LV23A device is enabled to receive from iso channel number 39.

Table 4–12. Isochronous Receive Channel Mask High Register Description (Continued)

BIT	FIELD NAME	TYPE	DESCRIPTION
6	isoChannel38	RSC	When this bit is set, the TSB12LV23A device is enabled to receive from iso channel number 38.
5	isoChannel37	RSC	When this bit is set, the TSB12LV23A device is enabled to receive from iso channel number 37.
4	isoChannel36	RSC	When this bit is set, the TSB12LV23A device is enabled to receive from iso channel number 36.
3	isoChannel35	RSC	When this bit is set, the TSB12LV23A device is enabled to receive from iso channel number 35.
2	isoChannel34	RSC	When this bit is set, the TSB12LV23A device is enabled to receive from iso channel number 34.
1	isoChannel33	RSC	When this bit is set, the TSB12LV23A device is enabled to receive from iso channel number 33.
0	isoChannel32	RSC	When this bit is set, the TSB12LV23A device is enabled to receive from iso channel number 32.

4.20 Isochronous Receive Channel Mask Low Register

The isochronous receive channel mask low set/clear register is used to enable packet receives from the lower 32 isochronous data channels. See Table 4–13 for a complete description of the register contents.

Bit	31	30	29	28	27	26	25	24	23	22	21	20	19	18	17	16
Name	Isochronous receive channel mask low															
Type	RSC	RSC	RSC	RSC	RSC	RSC	RSC	RSC	RSC	RSC	RSC	RSC	RSC	RSC	RSC	RSC
Default	X	X	X	X	X	X	X	X	X	X	X	X	X	X	X	X
Bit	15	14	13	12	11	10	9	8	7	6	5	4	3	2	1	0
Name	Isochronous receive channel mask low															
Type	RSC	RSC	RSC	RSC	RSC	RSC	RSC	RSC	RSC	RSC	RSC	RSC	RSC	RSC	RSC	RSC
Default	X	X	X	X	X	X	X	X	X	X	X	X	X	X	X	X

Register: **Isochronous receive channel mask low**

Type: Read/Set/Clear

Offset: 78h set register
7Ch clear register

Default: XXXX XXXXh

Table 4–13. Isochronous Receive Channel Mask Low Register Description

BIT	FIELD NAME	TYPE	DESCRIPTION
31	isoChannel31	RSC	When this bit is set, the TSB12LV23A device is enabled to receive from iso channel number 31.
30	isoChannel30	RSC	When this bit is set, the TSB12LV23A device is enabled to receive from iso channel number 30.
:	:	:	Bits 29 through 2 follow the same pattern.
1	isoChannel1	RSC	When this bit is set, the TSB12LV23A device is enabled to receive from iso channel number 1.
0	isoChannel0	RSC	When this bit is set, the TSB12LV23A device is enabled to receive from iso channel number 0.

4.21 Interrupt Event Register

The interrupt event set/clear register reflects the state of the various TSB12LV23A interrupt sources. The interrupt bits are set by an asserting edge of the corresponding interrupt signal or by writing a 1 in the corresponding bit in the set register. The only mechanism to clear a bit in this register is to write a 1 to the corresponding bit in the clear register.

This register is fully compliant with the *1394 Open Host Controller Interface Specification*, and the TSB12LV23A device adds a vendor-specific interrupt function to bit 30. When the interrupt event register is read, the return value is the bit-wise AND function of the interrupt event and interrupt mask registers. See Table 4–14 for a complete description of the register contents.

Bit	31	30	29	28	27	26	25	24	23	22	21	20	19	18	17	16
Name	Interrupt event															
Type	R	RSC	R	R	R	RSCU	RSCU	RSCU	RSCU	RSCU	RSCU	RSCU	RSCU	R	RSCU	RSCU
Default	0	X	0	0	0	X	X	X	X	X	X	X	X	0	X	X
Bit	15	14	13	12	11	10	9	8	7	6	5	4	3	2	1	0
Name	Interrupt event															
Type	R	R	R	R	R	R	RSCU	RSCU	RU	RU	RSCU	RSCU	RSCU	RSCU	RSCU	RSCU
Default	0	0	0	0	0	0	X	X	X	X	X	X	X	X	X	X

Register: **Interrupt event**
 Type: Read/Set/Clear/Update, Read/Set/Clear, Read/Update, Read-only
 Offset: 80h set register
 84h clear register [returns the content of the interrupt event register bitwise ANDed with the interrupt mask register when read]
 Default: XXXX 0XXXh

Table 4–14. Interrupt Event Register Description

BIT	FIELD NAME	TYPE	DESCRIPTION
31	RSVD	R	Reserved. Bit 31 returns 0 when read.
30	vendorSpecific	RSC	This vendor-specific interrupt event is reported when either of the general-purpose interrupts which are enabled via bit 31 (INT_3EN) and bit 23 (INT_2EN) of the GPIO control register (offset FCh, see Section 3.25).
29–27	RSVD	R	Reserved. Bits 29–27 return 0s when read.
26	phyRegRcvd	RSCU	The TSB12LV23A device has received a PHY register data byte which can be read from bits 23–16 in the PHY layer control register (OHCI offset ECh, see Section 4.30).
25	cycleTooLong	RSCU	If bit 21 (cycleMaster) of the link control register (OHCI offset E0h/E4h, see Section 4.28) is set, then this indicates that over 125 μs have elapsed between the start of sending a cycle start packet and the end of a subaction gap. The link control register bit 21 (cycleMaster) is cleared by this event.
24	unrecoverableError	RSCU	This event occurs when the TSB12LV23A device encounters any error that forces it to stop operations on any or all of its subunits, for example, when a DMA context sets its dead bit. While this bit is set, all normal interrupts for the context(s) that caused this interrupt are blocked from being set.
23	cycleInconsistent	RSCU	A cycle start was received that had values for cycleSeconds and cycleCount fields that are different from the values in bits 31–25 (cycleSeconds field) and bits 24–12 (cycleCount field) of the isochronous cycle timer register (OHCI offset F0h, see Section 4.31).
22	cycleLost	RSCU	A lost cycle is indicated when no cycle_start packet is sent/received between two successive cycleSynch events. A lost cycle can be predicted when a cycle_start packet does not immediately follow the first subaction gap after the cycleSynch event or if an arbitration reset gap is detected after a cycleSynch event without an intervening cycle start. This bit may be set either when a lost cycle occurs or when logic predicts that one will occur.
21	cycle64Seconds	RSCU	Indicates that the 7 th bit of the cycle second counter has changed.
20	cycleSynch	RSCU	Indicates that a new isochronous cycle has started. This bit is set when the low order bit of the cycle count toggles.

Table 4–14. Interrupt Event Register Description (Continued)

BIT	FIELD NAME	TYPE	DESCRIPTION
19	phy	RSCU	Indicates that the PHY device requests an interrupt through a status transfer.
18	RSVD	R	Reserved. Bit 18 returns 0 when read.
17	busReset	RSCU	Indicates that the PHY device has entered bus reset mode.
16	selfIDcomplete	RSCU	A self-ID packet stream has been received. It is generated at the end of the bus initialization process. This bit is turned off simultaneously when bit 17 (busReset) is turned on.
15–10	RSVD	R	Reserved. Bits 15–10 return 0s when read.
9	lockRespErr	RSCU	Indicates that the TSB12LV23A device sent a lock response for a lock request to a serial bus register, but did not receive an ack_complete.
8	postedWriteErr	RSCU	Indicates that a host bus error occurred while the TSB12LV23A device was trying to write a 1394 write request, which had already been given an ack_complete, into system memory.
7	isochRx	RU	Isochronous receive DMA interrupt. Indicates that one or more isochronous receive contexts have generated an interrupt. This is not a latched event; it is the logical OR of all bits in the isochronous receive interrupt event (OHCI offset A0h/A4h, see Section 4.25) and isochronous receive interrupt mask (OHCI offset A8h/AC, see Section 4.26) registers. The isochronous receive interrupt event register indicates which contexts have interrupted.
6	isochTx	RU	Isochronous transmit DMA interrupt. Indicates that one or more isochronous transmit contexts have generated an interrupt. This is not a latched event; it is the logical OR of all bits in the isochronous transmit interrupt event (OHCI offset 90h/94h, see Section 4.23) and isochronous transmit interrupt mask (OHCI offset 98h/9C, see Section 4.24) registers. The isochronous transmit interrupt event register indicates which contexts have interrupted.
5	RSPkt	RSCU	Indicates that a packet was sent to an asynchronous receive response context buffer and the descriptor xferStatus and resCount fields have been updated.
4	RQPkt	RSCU	Indicates that a packet was sent to an asynchronous receive request context buffer and the descriptor xferStatus and resCount fields have been updated.
3	ARRS	RSCU	Asynchronous receive response DMA interrupt. This bit is conditionally set upon completion of an ARRS DMA context command descriptor.
2	ARRQ	RSCU	Asynchronous receive request DMA interrupt. This bit is conditionally set upon completion of an ARRQ DMA context command descriptor.
1	respTxComplete	RSCU	Asynchronous response transmit DMA interrupt. This bit is conditionally set upon completion of an ATRS DMA command.
0	reqTxComplete	RSCU	Asynchronous request transmit DMA interrupt. This bit is conditionally set upon completion of an ATRQ DMA command.

4.22 Interrupt Mask Register

The interrupt mask set/clear register is used to enable the various TSB12LV23A interrupt sources. Reads from either the set register or the clear register always return the contents of the interrupt mask register. In all cases except masterIntEnable (bit 31) and VendorSpecific (bit 30), the enables for each interrupt event align with the interrupt event register bits detailed in Table 4–14. See Table 4–15 for a complete description of bits 31 and 30.

This register is fully compliant with the *1394 Open Host Controller Interface Specification* and the TSB12LV23A device adds an interrupt function to bit 30.

Bit	31	30	29	28	27	26	25	24	23	22	21	20	19	18	17	16
Name	Interrupt mask															
Type	RSCU	RSC	R	R	R	RSCU	RSCU	RSCU	RSCU	RSCU	RSCU	RSCU	RSCU	R	RSCU	RSCU
Default	X	X	0	0	0	X	X	X	X	X	X	X	X	0	X	X
Bit	15	14	13	12	11	10	9	8	7	6	5	4	3	2	1	0
Name	Interrupt mask															
Type	R	R	R	R	R	R	RSCU	RSCU	RU	RU	RSCU	RSCU	RSCU	RSCU	RSCU	RSCU
Default	0	0	0	0	0	0	X	X	X	X	X	X	X	X	X	X

Register: **Interrupt mask**
 Type: Read/Set/Clear/Update, Read/Set/Clear, Read/Update, Read-only
 Offset: 88h set register
 8Ch clear register
 Default: XXXX 0XXXh

Table 4–15. Interrupt Mask Register Description

BIT	FIELD NAME	TYPE	DESCRIPTION
31	masterIntEnable	RSCU	Master interrupt enable. If this bit is set, then external interrupts are generated in accordance with the interrupt mask register. If this bit is cleared, then external interrupts are not generated regardless of the interrupt mask register settings.
30	VendorSpecific	RSC	When this bit is set, this vendor-specific interrupt mask enables interrupt generation when bit 30 (vendorSpecific) of the interrupt event register (OHCI offset 80h/84h, see Section 4.21) is set.
29–0			See Table 4–14.

4.23 Isochronous Transmit Interrupt Event Register

The isochronous transmit interrupt event set/clear register reflects the interrupt state of the isochronous transmit contexts. An interrupt is generated on behalf of an isochronous transmit context if an OUTPUT_LAST* command completes and its interrupt bits are set. Upon determining that the interrupt event register (OHC1 offset 80h/84h, see Section 4.21) isoTx (bit 6) interrupt has occurred, software can check this register to determine which context(s) caused the interrupt. The interrupt bits are set by an asserting edge of the corresponding interrupt signal, or by writing a 1 in the corresponding bit in the set register. The only mechanism to clear a bit in this register is to write a 1 to the corresponding bit in the clear register. See Table 4–16 for a complete description of the register contents.

Bit	31	30	29	28	27	26	25	24	23	22	21	20	19	18	17	16
Name	Isochronous transmit interrupt event															
Type	R	R	R	R	R	R	R	R	R	R	R	R	R	R	R	R
Default	0	0	0	0	0	0	0	0	0	0	0	0	0	0	0	0
Bit	15	14	13	12	11	10	9	8	7	6	5	4	3	2	1	0
Name	Isochronous transmit interrupt event															
Type	R	R	R	R	R	R	R	R	RSC	RSC	RSC	RSC	RSC	RSC	RSC	RSC
Default	0	0	0	0	0	0	0	0	X	X	X	X	X	X	X	X

Register: **Isochronous transmit interrupt event**
 Type: Read/Set/Clear, Read-only
 Offset: 90h set register
 94h clear register [returns the contents of the isochronous transmit interrupt event register bitwise ANDed with the isochronous transmit interrupt mask register when read]
 Default: 0000 00XXh

Table 4–16. Isochronous Transmit Interrupt Event Register Description

BIT	FIELD NAME	TYPE	DESCRIPTION
31–8	RSVD	R	Reserved. Bits 31–8 return 0s when read.
7	isoXmit7	RSC	Isochronous transmit channel 7 caused the interrupt event register bit 6 (isoTx) interrupt.
6	isoXmit6	RSC	Isochronous transmit channel 6 caused the interrupt event register bit 6 (isoTx) interrupt.
5	isoXmit5	RSC	Isochronous transmit channel 5 caused the interrupt event register bit 6 (isoTx) interrupt.
4	isoXmit4	RSC	Isochronous transmit channel 4 caused the interrupt event register bit 6 (isoTx) interrupt.
3	isoXmit3	RSC	Isochronous transmit channel 3 caused the interrupt event register bit 6 (isoTx) interrupt.
2	isoXmit2	RSC	Isochronous transmit channel 2 caused the interrupt event register bit 6 (isoTx) interrupt.
1	isoXmit1	RSC	Isochronous transmit channel 1 caused the interrupt event register bit 6 (isoTx) interrupt.
0	isoXmit0	RSC	Isochronous transmit channel 0 caused the interrupt event register bit 6 (isoTx) interrupt.

4.24 Isochronous Transmit Interrupt Mask Register

The isochronous transmit interrupt mask set/clear register is used to enable the isochTx interrupt source on a per-channel basis. Reads from either the set register or the clear register always return the contents of the isochronous transmit interrupt mask register. In all cases the enables for each interrupt event align with the isochronous transmit interrupt event register bits detailed in Table 4–16.

Bit	31	30	29	28	27	26	25	24	23	22	21	20	19	18	17	16
Name	Isochronous transmit interrupt mask															
Type	R	R	R	R	R	R	R	R	R	R	R	R	R	R	R	R
Default	0	0	0	0	0	0	0	0	0	0	0	0	0	0	0	0
Bit	15	14	13	12	11	10	9	8	7	6	5	4	3	2	1	0
Name	Isochronous transmit interrupt mask															
Type	R	R	R	R	R	R	R	R	RSC	RSC	RSC	RSC	RSC	RSC	RSC	RSC
Default	0	0	0	0	0	0	0	0	X	X	X	X	X	X	X	X

Register: **Isochronous transmit interrupt mask**

Type: Read/Set/Clear, Read-only

Offset: 98h set register

9Ch clear register

Default: 0000 00XXh

4.25 Isochronous Receive Interrupt Event Register

The isochronous receive interrupt event set/clear register reflects the interrupt state of the isochronous receive contexts. An interrupt is generated on behalf of an isochronous receive context if an INPUT_* command completes and its interrupt bits are set. Upon determining that the interrupt event register (OHCI offset 80h/84h, see Section 4.21) isochRx (bit 7) interrupt has occurred, software can check this register to determine which context(s) caused the interrupt. An interrupt bit is set by an asserting edge of the corresponding interrupt signal, or by writing a 1 in the corresponding bit in the set register. The only mechanism to clear a bit in this register is to write a 1 to the corresponding bit in the clear register. See Table 4–17 for a complete description of the register contents.

Bit	31	30	29	28	27	26	25	24	23	22	21	20	19	18	17	16
Name	Isochronous receive interrupt event															
Type	R	R	R	R	R	R	R	R	R	R	R	R	R	R	R	R
Default	0	0	0	0	0	0	0	0	0	0	0	0	0	0	0	0
Bit	15	14	13	12	11	10	9	8	7	6	5	4	3	2	1	0
Name	Isochronous receive interrupt event															
Type	R	R	R	R	R	R	R	R	R	R	R	R	RSC	RSC	RSC	RSC
Default	0	0	0	0	0	0	0	0	0	0	0	0	X	X	X	X

Register: **Isochronous receive interrupt event**

Type: Read/Set/Clear, Read-only

Offset: A0h set register

A4h clear register [returns the contents of the isochronous receive interrupt event register bitwise ANDed with the isochronous receive interrupt mask register when read]

Default: 0000 000Xh

Table 4–17. Isochronous Receive Interrupt Event Register Description

BIT	FIELD NAME	TYPE	DESCRIPTION
31–4	RSVD	R	Reserved. Bits 31–4 return 0s when read.
3	isoRecv3	RSC	Isochronous receive channel 3 caused the interrupt event register bit 7 (isochRx) interrupt.
2	isoRecv2	RSC	Isochronous receive channel 2 caused the interrupt event register bit 7 (isochRx) interrupt.
1	isoRecv1	RSC	Isochronous receive channel 1 caused the interrupt event register bit 7 (isochRx) interrupt.
0	isoRecv0	RSC	Isochronous receive channel 0 caused the interrupt event register bit 7 (isochRx) interrupt.

4.26 Isochronous Receive Interrupt Mask Register

The isochronous receive interrupt mask register is used to enable the isochRx interrupt source on a per-channel basis. Reads from either the set register or the clear register always return the contents of the isochronous receive interrupt mask register. In all cases the enables for each interrupt event align with the isochronous receive interrupt event register bits detailed in Table 4–17.

Bit	31	30	29	28	27	26	25	24	23	22	21	20	19	18	17	16
Name	Isochronous receive interrupt mask															
Type	R	R	R	R	R	R	R	R	R	R	R	R	R	R	R	R
Default	0	0	0	0	0	0	0	0	0	0	0	0	0	0	0	0
Bit	15	14	13	12	11	10	9	8	7	6	5	4	3	2	1	0
Name	Isochronous receive interrupt mask															
Type	R	R	R	R	R	R	R	R	R	R	R	R	RSC	RSC	RSC	RSC
Default	0	0	0	0	0	0	0	0	0	0	0	0	X	X	X	X

Register: **Isochronous receive interrupt mask**
 Type: Read/Set/Clear, Read-only
 Offset: A8h set register
 ACh clear register
 Default: 0000 000Xh

4.27 Fairness Control Register

The fairness control register provides a mechanism by which software can direct the host controller to transmit multiple asynchronous requests during a fairness interval. See Table 4–18 for a complete description of the register contents.

Bit	31	30	29	28	27	26	25	24	23	22	21	20	19	18	17	16
Name	Fairness control															
Type	R	R	R	R	R	R	R	R	R	R	R	R	R	R	R	R
Default	0	0	0	0	0	0	0	0	0	0	0	0	0	0	0	0
Bit	15	14	13	12	11	10	9	8	7	6	5	4	3	2	1	0
Name	Fairness control															
Type	R	R	R	R	R	R	R	R	R/W	R/W	R/W	R/W	R/W	R/W	R/W	R/W
Default	0	0	0	0	0	0	0	0	0	0	0	0	0	0	0	0

Register: **Fairness control**
 Type: Read-only, Read/Write
 Offset: DCh
 Default: 0000 0000h

Table 4–18. Fairness Control Register Description

BIT	FIELD NAME	TYPE	DESCRIPTION
31–8	RSVD	R	Reserved. Bits 31–8 return 0s when read.
7–0	pri_req	R/W	This field specifies the maximum number of priority arbitration requests for asynchronous request packets that the link is permitted to make of the PHY device during a fairness interval.

4.28 Link Control Register

The link control set/clear register provides the control flags that enable and configure the link core protocol portions of the TSB12LV23A device. It contains controls for the receiver and cycle timer. See Table 4–19 for a complete description of the register contents.

Bit	31	30	29	28	27	26	25	24	23	22	21	20	19	18	17	16
Name	Link control															
Type	R	R	R	R	R	R	R	R	R	RSC	RSCU	RSC	R	R	R	R
Default	0	0	0	0	0	0	0	0	0	X	X	X	0	0	0	0
Bit	15	14	13	12	11	10	9	8	7	6	5	4	3	2	1	0
Name	Link control															
Type	R	R	R	R	R	RSC	RSC	R	R	R	R	R	R	R	R	R
Default	0	0	0	0	0	X	X	0	0	0	0	0	0	0	0	0

Register: **Link control**
 Type: Read/Set/Clear/Update, Read/Set/Clear, Read-only
 Offset: E0h set register
 E4h clear register
 Default: 00X0 0X00h

Table 4–19. Link Control Register Description

BIT	FIELD NAME	TYPE	DESCRIPTION
31–23	RSVD	R	Reserved. Bits 31–23 return 0s when read.
22	cycleSource	RSC	When this bit is set, the cycle timer uses an external source (CYCLEIN) to determine when to roll over the cycle timer. When this bit is cleared, the cycle timer rolls over when the timer reaches 3072 cycles of the 24.576-MHz clock (125 μs).
21	cycleMaster	RSCU	When bit 21 is set and the PHY device has notified the TSB12LV23A device that the PHY device is root, the TSB12LV23A device generates a cycle start packet every time the cycle timer rolls over, based on the setting of bit 22 (cycleSource). When bit 21 is cleared, the OHCI-Lynx™ accepts received cycle start packets to maintain synchronization with the node which is sending them. Bit 21 is automatically cleared when bit 25 (cycleTooLong) of the interrupt event register (OHCI offset 80h/84h, see Section 4.21) is set. Bit 21 cannot be set until bit 25 (cycleTooLong) is cleared.
20	CycleTimerEnable	RSC	When this bit is set, the cycle timer offset counts cycles of the 24.576-MHz clock and rolls over at the appropriate time based on the settings of the above bits. When this bit is cleared, the cycle timer offset does not count.
19–11	RSVD	R	Reserved. Bits 19–11 return 0s when read.
10	RcvPhyPkt	RSC	When this bit is set, the receiver accepts incoming PHY packets into the AR request context if the AR request context is enabled. This does not control receipt of self-ID packets.
9	RcvSelfID	RSC	When this bit is set, the receiver accepts incoming self-ID packets. Before setting this bit to 1, software must ensure that the self-ID buffer pointer register contains a valid address.
8–0	RSVD	R	Reserved. Bits 8–0 return 0s when read.

4.29 Node Identification Register

The node identification register contains the address of the node on which the OHCI-Lynx™ chip resides, and indicates the valid node number status. The 16-bit combination of the busNumber field (bits 15–6) and the NodeNumber field (bits 5–0) is referred to as the node ID. See Table 4–20 for a complete description of the register contents.

Bit	31	30	29	28	27	26	25	24	23	22	21	20	19	18	17	16
Name	Node identification															
Type	RU	RU	R	R	RU	R	R	R	R	R	R	R	R	R	R	R
Default	0	0	0	0	0	0	0	0	0	0	0	0	0	0	0	0
Bit	15	14	13	12	11	10	9	8	7	6	5	4	3	2	1	0
Name	Node identification															
Type	RWU	RWU	RWU	RWU	RWU	RWU	RWU	RWU	RWU	RWU	RU	RU	RU	RU	RU	RU
Default	1	1	1	1	1	1	1	1	1	1	X	X	X	X	X	X

Register: **Node identification**
 Type: Read/Write/Update, Read/Update, Read-only
 Offset: E8h
 Default: 0000 FFXXh

Table 4–20. Node Identification Register Description

BIT	FIELD NAME	TYPE	DESCRIPTION
31	iDValid	RU	This bit indicates whether or not the TSB12LV23A device has a valid node number. It is cleared when a 1394 bus reset is detected and set when the TSB12LV23A device receives a new node number from the PHY device.
30	root	RU	This bit is set during the bus reset process if the attached PHY device is root.
29–28	RSVD	R	Reserved. Bits 29–28 return 0s when read.
27	CPS	RU	This bit is set if the PHY device is reporting that cable power status is OK.
26–16	RSVD	R	Reserved. Bits 26–16 return 0s when read.
15–6	BusNumber	RWU	This number is used to identify the specific 1394 bus the TSB12LV23A device belongs to when multiple 1394-compatible buses are connected via a bridge.
5–0	NodeNumber	RU	This number is the physical node number established by the PHY device during self-ID. It is automatically set to the value received from the PHY device after the self-ID phase. If the PHY device sets the NodeNumber to 63, then software should not set bit 15 (run) of the asynchronous context control register (see Section 4.37) for either of the AT DMA contexts.

4.30 PHY Layer Control Register

The PHY layer control register is used to read or write a PHY register. See Table 4–21 for a complete description of the register contents.

Bit	31	30	29	28	27	26	25	24	23	22	21	20	19	18	17	16
Name	PHY layer control															
Type	RU	R	R	R	RU	RU	RU	RU	RU	RU	RU	RU	RU	RU	RU	RU
Default	0	0	0	0	0	0	0	0	0	0	0	0	0	0	0	0
Bit	15	14	13	12	11	10	9	8	7	6	5	4	3	2	1	0
Name	PHY layer control															
Type	RWU	RWU	R	R	R/W	R/W	R/W	R/W	R/W	R/W	R/W	R/W	R/W	R/W	R/W	R/W
Default	0	0	0	0	0	0	0	0	0	0	0	0	0	0	0	0

Register: **PHY layer control**
 Type: Read/Write/Update, Read/Write, Read/Update, Read-only
 Offset: ECh
 Default: 0000 0000h

Table 4–21. PHY Control Register Description

BIT	FIELD NAME	TYPE	DESCRIPTION
31	rdDone	RU	This bit is cleared to 0 by the TSB12LV23A device when either bit 15 (rdReg) or bit 14 (wrReg) is set. This bit is set when a register transfer is received from the PHY device.
30–28	RSVD	R	Reserved. Bits 30–28 return 0s when read.
27–24	rdAddr	RU	This is the address of the register most recently received from the PHY device.
23–16	rdData	RU	This field is the contents of a PHY register that has been read.
15	rdReg	RWU	This bit is set by software to initiate a read request to a PHY register and is cleared by hardware when the request has been sent. Bits 14 (wrReg) and 15 (rdReg) must not both be set simultaneously.
14	wrReg	RWU	This bit is set by software to initiate a write request to a PHY register and is cleared by hardware when the request has been sent. Bits 14 (wrReg) and 15 (rdReg) must not both be set simultaneously.
13–12	RSVD	R	Reserved. Bits 13–12 return 0s when read.
11–8	regAddr	R/W	This field is the address of the PHY register to be written or read.
7–0	wrData	R/W	This field is the data to be written to a PHY register and is ignored for reads.

4.31 Isochronous Cycle Timer Register

The isochronous cycle timer register indicates the current cycle number and offset. When the TSB12LV23A device is cycle master, this register is transmitted with the cycle start message. When the TSB12LV23A device is not cycle master, this register is loaded with the data field in an incoming cycle start. In the event that the cycle start message is not received, the fields can continue incrementing on their own (if programmed) to maintain a local time reference. See Table 4–22 for a complete description of the register contents.

Bit	31	30	29	28	27	26	25	24	23	22	21	20	19	18	17	16
Name	Isochronous cycle timer															
Type	RWU	RWU	RWU	RWU	RWU	RWU	RWU	RWU	RWU	RWU	RWU	RWU	RWU	RWU	RWU	RWU
Default	X	X	X	X	X	X	X	X	X	X	X	X	X	X	X	X
Bit	15	14	13	12	11	10	9	8	7	6	5	4	3	2	1	0
Name	Isochronous cycle timer															
Type	RWU	RWU	RWU	RWU	RWU	RWU	RWU	RWU	RWU	RWU	RWU	RWU	RWU	RWU	RWU	RWU
Default	X	X	X	X	X	X	X	X	X	X	X	X	X	X	X	X

Register: **Isochronous cycle timer**
 Type: Read/Write/Update
 Offset: F0h
 Default: XXXX XXXXh

Table 4–22. Isochronous Cycle Timer Register Description

BIT	FIELD NAME	TYPE	DESCRIPTION
31–25	cycleSeconds	RWU	This field counts seconds [rollovers from bits 24–12 (cycleCount field)] modulo 128.
24–12	cycleCount	RWU	This field counts cycles [rollovers from bits 11–0 (cycleOffset field)] modulo 8000.
11–0	cycleOffset	RWU	This field counts 24.576-MHz clocks modulo 3072, that is, 125 μs. If an external 8-kHz clock configuration is being used, then this bit must be cleared at each tick of the external clock.

4.32 Asynchronous Request Filter High Register

The asynchronous request filter high set/clear register is used to enable asynchronous receive requests on a per-node basis, and handles the upper node IDs. When a packet is destined for either the physical request context or the ARRQ context, the source node ID is examined. If the bit corresponding to the node ID is not set in this register, then the packet is not acknowledged and the request is not queued. The node ID comparison is done if the source node is on the same bus as the TSB12LV23A device. Nonlocal bus-sourced packets are not acknowledged unless bit 31 in this register is set. See Table 4–23 for a complete description of the register contents.

Bit	31	30	29	28	27	26	25	24	23	22	21	20	19	18	17	16
Name	Asynchronous request filter high															
Type	RSC	RSC	RSC	RSC	RSC	RSC	RSC	RSC	RSC	RSC	RSC	RSC	RSC	RSC	RSC	RSC
Default	0	0	0	0	0	0	0	0	0	0	0	0	0	0	0	0
Bit	15	14	13	12	11	10	9	8	7	6	5	4	3	2	1	0
Name	Asynchronous request filter high															
Type	RSC	RSC	RSC	RSC	RSC	RSC	RSC	RSC	RSC	RSC	RSC	RSC	RSC	RSC	RSC	RSC
Default	0	0	0	0	0	0	0	0	0	0	0	0	0	0	0	0

Register: **Asynchronous request filter high**
 Type: Read/Set/Clear
 Offset: 100h set register
 104h clear register
 Default: 0000 0000h

Table 4–23. Asynchronous Request Filter High Register Description

BIT	FIELD NAME	TYPE	DESCRIPTION
31	asynReqAllBuses	RSC	If this bit is set, then all asynchronous requests received by the TSB12LV23A device from nonlocal bus nodes are accepted.
30	asynReqResource62	RSC	If this bit is set for local bus node number 62, then asynchronous requests received by the TSB12LV23A device from that node are accepted.
29	asynReqResource61	RSC	If this bit is set for local bus node number 61, then asynchronous requests received by the TSB12LV23A device from that node are accepted.
28	asynReqResource60	RSC	If this bit is set for local bus node number 60, then asynchronous requests received by the TSB12LV23A device from that node are accepted.
27	asynReqResource59	RSC	If this bit is set for local bus node number 59, then asynchronous requests received by the TSB12LV23A device from that node are accepted.
26	asynReqResource58	RSC	If this bit is set for local bus node number 58, then asynchronous requests received by the TSB12LV23A device from that node are accepted.
25	asynReqResource57	RSC	If this bit is set for local bus node number 57, then asynchronous requests received by the TSB12LV23A device from that node are accepted.
24	asynReqResource56	RSC	If this bit is set for local bus node number 56, then asynchronous requests received by the TSB12LV23A device from that node are accepted.
23	asynReqResource55	RSC	If this bit is set for local bus node number 55, then asynchronous requests received by the TSB12LV23A device from that node are accepted.
22	asynReqResource54	RSC	If this bit is set for local bus node number 54, then asynchronous requests received by the TSB12LV23A device from that node are accepted.
21	asynReqResource53	RSC	If this bit is set for local bus node number 53, then asynchronous requests received by the TSB12LV23A device from that node are accepted.
20	asynReqResource52	RSC	If this bit is set for local bus node number 52, then asynchronous requests received by the TSB12LV23A device from that node are accepted.
19	asynReqResource51	RSC	If this bit is set for local bus node number 51, then asynchronous requests received by the TSB12LV23A device from that node are accepted.

Table 4–23. Asynchronous Request Filter High Register Description (Continued)

BIT	FIELD NAME	TYPE	DESCRIPTION
18	asynReqResource50	RSC	If this bit is set for local bus node number 50, then asynchronous requests received by the TSB12LV23A device from that node are accepted.
17	asynReqResource49	RSC	If this bit is set for local bus node number 49, then asynchronous requests received by the TSB12LV23A device from that node are accepted.
16	asynReqResource48	RSC	If this bit is set for local bus node number 48, then asynchronous requests received by the TSB12LV23A device from that node are accepted.
15	asynReqResource47	RSC	If this bit is set for local bus node number 47, then asynchronous requests received by the TSB12LV23A device from that node are accepted.
14	asynReqResource46	RSC	If this bit is set for local bus node number 46, then asynchronous requests received by the TSB12LV23A device from that node are accepted.
13	asynReqResource45	RSC	If this bit is set for local bus node number 45, then asynchronous requests received by the TSB12LV23A device from that node are accepted.
12	asynReqResource44	RSC	If this bit is set for local bus node number 44, then asynchronous requests received by the TSB12LV23A device from that node are accepted.
11	asynReqResource43	RSC	If this bit is set for local bus node number 43, then asynchronous requests received by the TSB12LV23A device from that node are accepted.
10	asynReqResource42	RSC	If this bit is set for local bus node number 42, then asynchronous requests received by the TSB12LV23A device from that node are accepted.
9	asynReqResource41	RSC	If this bit is set for local bus node number 41, then asynchronous requests received by the TSB12LV23A device from that node are accepted.
8	asynReqResource40	RSC	If this bit is set for local bus node number 40, then asynchronous requests received by the TSB12LV23A device from that node are accepted.
7	asynReqResource39	RSC	If this bit is set for local bus node number 39, then asynchronous requests received by the TSB12LV23A device from that node are accepted.
6	asynReqResource38	RSC	If this bit is set for local bus node number 38, then asynchronous requests received by the TSB12LV23A device from that node are accepted.
5	asynReqResource37	RSC	If this bit is set for local bus node number 37, then asynchronous requests received by the TSB12LV23A device from that node are accepted.
4	asynReqResource36	RSC	If this bit is set for local bus node number 36, then asynchronous requests received by the TSB12LV23A device from that node are accepted.
3	asynReqResource35	RSC	If this bit is set for local bus node number 35, then asynchronous requests received by the TSB12LV23A device from that node are accepted.
2	asynReqResource34	RSC	If this bit is set for local bus node number 34, then asynchronous requests received by the TSB12LV23A device from that node are accepted.
1	asynReqResource33	RSC	If this bit is set for local bus node number 33, then asynchronous requests received by the TSB12LV23A device from that node are accepted.
0	asynReqResource32	RSC	If this bit is set for local bus node number 32, then asynchronous requests received by the TSB12LV23A device from that node are accepted.

4.33 Asynchronous Request Filter Low Register

The asynchronous request filter low set/clear register is used to enable asynchronous receive requests on a per-node basis, and handles the lower node IDs. Other than filtering different node IDs, this register behaves identically to the asynchronous request filter high register. See Table 4–24 for a complete description of the register contents.

Bit	31	30	29	28	27	26	25	24	23	22	21	20	19	18	17	16
Name	Asynchronous request filter low															
Type	RSC	RSC	RSC	RSC	RSC	RSC	RSC	RSC	RSC	RSC	RSC	RSC	RSC	RSC	RSC	RSC
Default	0	0	0	0	0	0	0	0	0	0	0	0	0	0	0	0
Bit	15	14	13	12	11	10	9	8	7	6	5	4	3	2	1	0
Name	Asynchronous request filter low															
Type	RSC	RSC	RSC	RSC	RSC	RSC	RSC	RSC	RSC	RSC	RSC	RSC	RSC	RSC	RSC	RSC
Default	0	0	0	0	0	0	0	0	0	0	0	0	0	0	0	0

Register: **Asynchronous request filter low**
 Type: Read/Set/Clear
 Offset: 108h set register
 10Ch clear register
 Default: 0000 0000h

Table 4–24. Asynchronous Request Filter Low Register Description

BIT	FIELD NAME	TYPE	DESCRIPTION
31	asynReqResource31	RSC	If this bit is set for local bus node number 31, then asynchronous requests received by the TSB12LV23A device from that node are accepted.
30	asynReqResource30	RSC	If this bit is set for local bus node number 30, then asynchronous requests received by the TSB12LV23A device from that node are accepted.
:	:	:	Bits 29 through 2 follow the same pattern.
1	asynReqResource1	RSC	If this bit is set for local bus node number 1, then asynchronous requests received by the TSB12LV23A device from that node are accepted.
0	asynReqResource0	RSC	If this bit is set for local bus node number 0, then asynchronous requests received by the TSB12LV23A device from that node are accepted.

4.34 Physical Request Filter High Register

The physical request filter high set/clear register is used to enable physical receive requests on a per-node basis and handles the upper node IDs. When a packet is destined for the physical request context and the node ID has been compared against the ARRQ registers, then the comparison is done again with this register. If the bit corresponding to the node ID is not set in this register, then the request is handled by the ARRQ context instead of the physical request context. The node ID comparison is done if the source node is on the same bus as the TSB12LV23A device. Nonlocal bus-sourced packets are not acknowledged unless bit 31 in this register is set. See Table 4–25 for a complete description of the register contents.

Bit	31	30	29	28	27	26	25	24	23	22	21	20	19	18	17	16
Name	Physical request filter high															
Type	RSC	RSC	RSC	RSC	RSC	RSC	RSC	RSC	RSC	RSC	RSC	RSC	RSC	RSC	RSC	RSC
Default	0	0	0	0	0	0	0	0	0	0	0	0	0	0	0	0
Bit	15	14	13	12	11	10	9	8	7	6	5	4	3	2	1	0
Name	Physical request filter high															
Type	RSC	RSC	RSC	RSC	RSC	RSC	RSC	RSC	RSC	RSC	RSC	RSC	RSC	RSC	RSC	RSC
Default	0	0	0	0	0	0	0	0	0	0	0	0	0	0	0	0

Register: **Physical request filter high**
 Type: Read/Set/Clear
 Offset: 110h set register
 114h clear register
 Default: 0000 0000h

Table 4–25. Physical Request Filter High Register Description

BIT	FIELD NAME	TYPE	DESCRIPTION
31	physReqAllBusses	RSC	If this bit is set, then all physical requests received by the TSB12LV23A device from nonlocal bus nodes are accepted.
30	physReqResource62	RSC	If this bit is set for local bus node number 62, then physical requests received by the TSB12LV23A device from that node are handled through the physical request context.
29	physReqResource61	RSC	If this bit is set for local bus node number 61, then physical requests received by the TSB12LV23A device from that node are handled through the physical request context.
28	physReqResource60	RSC	If this bit is set for local bus node number 60, then physical requests received by the TSB12LV23A device from that node are handled through the physical request context.
27	physReqResource59	RSC	If this bit is set for local bus node number 59, then physical requests received by the TSB12LV23A device from that node are handled through the physical request context.
26	physReqResource58	RSC	If this bit is set for local bus node number 58, then physical requests received by the TSB12LV23A device from that node are handled through the physical request context.
25	physReqResource57	RSC	If this bit is set for local bus node number 57, then physical requests received by the TSB12LV23A device from that node are handled through the physical request context.
24	physReqResource56	RSC	If this bit is set for local bus node number 56, then physical requests received by the TSB12LV23A device from that node are handled through the physical request context.
23	physReqResource55	RSC	If this bit is set for local bus node number 55, then physical requests received by the TSB12LV23A device from that node are handled through the physical request context.
22	physReqResource54	RSC	If this bit is set for local bus node number 54, then physical requests received by the TSB12LV23A device from that node are handled through the physical request context.
21	physReqResource53	RSC	If this bit is set for local bus node number 53, then physical requests received by the TSB12LV23A device from that node are handled through the physical request context.
20	physReqResource52	RSC	If this bit is set for local bus node number 52, then physical requests received by the TSB12LV23A device from that node are handled through the physical request context.

Table 4–25. Physical Request Filter High Register Description (Continued)

BIT	FIELD NAME	TYPE	DESCRIPTION
19	physReqResource51	RSC	If this bit is set for local bus node number 51, then physical requests received by the TSB12LV23A device from that node are handled through the physical request context.
18	physReqResource50	RSC	If this bit is set for local bus node number 50, then physical requests received by the TSB12LV23A device from that node are handled through the physical request context.
17	physReqResource49	RSC	If this bit is set for local bus node number 49, then physical requests received by the TSB12LV23A device from that node are handled through the physical request context.
16	physReqResource48	RSC	If this bit is set for local bus node number 48, then physical requests received by the TSB12LV23A device from that node are handled through the physical request context.
15	physReqResource47	RSC	If this bit is set for local bus node number 47, then physical requests received by the TSB12LV23A device from that node are handled through the physical request context.
14	physReqResource46	RSC	If this bit is set for local bus node number 46, then physical requests received by the TSB12LV23A device from that node are handled through the physical request context.
13	physReqResource45	RSC	If this bit is set for local bus node number 45, then physical requests received by the TSB12LV23A device from that node are handled through the physical request context.
12	physReqResource44	RSC	If this bit is set for local bus node number 44, then physical requests received by the TSB12LV23A device from that node are handled through the physical request context.
11	physReqResource43	RSC	If this bit is set for local bus node number 43, then physical requests received by the TSB12LV23A device from that node are handled through the physical request context.
10	physReqResource42	RSC	If this bit is set for local bus node number 42, then physical requests received by the TSB12LV23A device from that node are handled through the physical request context.
9	physReqResource41	RSC	If this bit is set for local bus node number 41, then physical requests received by the TSB12LV23A device from that node are handled through the physical request context.
8	physReqResource40	RSC	If this bit is set for local bus node number 40, then physical requests received by the TSB12LV23A device from that node are handled through the physical request context.
7	physReqResource39	RSC	If this bit is set for local bus node number 39, then physical requests received by the TSB12LV23A device from that node are handled through the physical request context.
6	physReqResource38	RSC	If this bit is set for local bus node number 38, then physical requests received by the TSB12LV23A device from that node are handled through the physical request context.
5	physReqResource37	RSC	If this bit is set for local bus node number 37, then physical requests received by the TSB12LV23A device from that node are handled through the physical request context.
4	physReqResource36	RSC	If this bit is set for local bus node number 36, then physical requests received by the TSB12LV23A device from that node are handled through the physical request context.
3	physReqResource35	RSC	If this bit is set for local bus node number 35, then physical requests received by the TSB12LV23A device from that node are handled through the physical request context.
2	physReqResource34	RSC	If this bit is set for local bus node number 34, then physical requests received by the TSB12LV23A device from that node are handled through the physical request context.
1	physReqResource33	RSC	If this bit is set for local bus node number 33, then physical requests received by the TSB12LV23A device from that node are handled through the physical request context.
0	physReqResource32	RSC	If this bit is set for local bus node number 32, then physical requests received by the TSB12LV23A device from that node are handled through the physical request context.

4.35 Physical Request Filter Low Register

The physical request filter low set/clear register is used to enable physical receive requests on a per-node basis and handles the lower node IDs. When a packet is destined for the physical request context and the node ID has been compared against the asynchronous request filter registers, then the node ID comparison is done again with this register. If the bit corresponding to the node ID is not set in this register, then the request is handled by the asynchronous request context instead of the physical request context. See Table 4–26 for a complete description of the register contents.

Bit	31	30	29	28	27	26	25	24	23	22	21	20	19	18	17	16
Name	Physical request filter low															
Type	RSC	RSC	RSC	RSC	RSC	RSC	RSC	RSC	RSC	RSC	RSC	RSC	RSC	RSC	RSC	RSC
Default	0	0	0	0	0	0	0	0	0	0	0	0	0	0	0	0
Bit	15	14	13	12	11	10	9	8	7	6	5	4	3	2	1	0
Name	Physical request filter low															
Type	RSC	RSC	RSC	RSC	RSC	RSC	RSC	RSC	RSC	RSC	RSC	RSC	RSC	RSC	RSC	RSC
Default	0	0	0	0	0	0	0	0	0	0	0	0	0	0	0	0

Register: **Physical request filter low**
 Type: Read/Set/Clear
 Offset: 118h set register
 11Ch clear register
 Default: 0000 0000h

Table 4–26. Physical Request Filter Low Register Description

BIT	FIELD NAME	TYPE	DESCRIPTION
31	physReqResource31	RSC	If this bit is set for local bus node number 31, then physical requests received by the TSB12LV23A device from that node are handled through the physical request context.
30	physReqResource30	RSC	If this bit is set for local bus node number 30, then physical requests received by the TSB12LV23A device from that node are handled through the physical request context.
:	:	:	Bits 29 through 2 follow the same pattern.
1	physReqResource1	RSC	If this bit is set for local bus node number 1, then physical requests received by the TSB12LV23A device from that node are handled through the physical request context.
0	physReqResource0	RSC	If this bit is set for local bus node number 0, then physical requests received by the TSB12LV23A device from that node are handled through the physical request context.

4.36 Physical Upper Bound Register (Optional Register)

The physical upper bound register is an optional register and is not implemented. It returns all 0s when read.

Bit	31	30	29	28	27	26	25	24	23	22	21	20	19	18	17	16
Name	Physical upper bound															
Type	R	R	R	R	R	R	R	R	R	R	R	R	R	R	R	R
Default	0	0	0	0	0	0	0	0	0	0	0	0	0	0	0	0
Bit	15	14	13	12	11	10	9	8	7	6	5	4	3	2	1	0
Name	Physical upper bound															
Type	R	R	R	R	R	R	R	R	R	R	R	R	R	R	R	R
Default	0	0	0	0	0	0	0	0	0	0	0	0	0	0	0	0

Register: **Physical upper bound**
 Type: Read-only
 Offset: 120h
 Default: 0000 0000h

4.37 Asynchronous Context Control Register

The asynchronous context control set/clear register controls the state and indicates status of the DMA context. See Table 4–27 for a complete description of the register contents.

Bit	31	30	29	28	27	26	25	24	23	22	21	20	19	18	17	16
Name	Asynchronous context control															
Type	R	R	R	R	R	R	R	R	R	R	R	R	R	R	R	R
Default	0	0	0	0	0	0	0	0	0	0	0	0	0	0	0	0
Bit	15	14	13	12	11	10	9	8	7	6	5	4	3	2	1	0
Name	Asynchronous context control															
Type	RSCU	R	R	RSU	RU	RU	R	R	RU	RU	RU	RU	RU	RU	RU	RU
Default	0	0	0	X	0	0	0	0	X	X	X	X	X	X	X	X

Register: **Asynchronous context control**
 Type: Read/Set/Clear/Update, Read/Set/Update, Read/Update, Read-only
 Offset: 180h set register [ATRQ]
 184h clear register [ATRQ]
 1A0h set register [ATRS]
 1A4h clear register [ATRS]
 1C0h set register [ARRQ]
 1C4h clear register [ARRQ]
 1E0h set register [ARRS]
 1E4h clear register [ARRS]
 Default: 0000 X0XXh

Table 4–27. Asynchronous Context Control Register Description

BIT	FIELD NAME	TYPE	DESCRIPTION
31–16	RSVD	R	Reserved. Bits 31–16 return 0s when read.
15	run	RSCU	This bit is set by software to enable descriptor processing for the context and cleared by software to stop descriptor processing. The TSB12LV23A device changes this bit only on a hardware or software reset.
14–13	RSVD	R	Reserved. Bits 14–13 return 0s when read.
12	wake	RSU	Software sets this bit to cause the TSB12LV23A device to continue or resume descriptor processing. The TSB12LV23A device clears this bit on every descriptor fetch.
11	dead	RU	The TSB12LV23A device sets this bit when it encounters a fatal error and clears the bit when software resets bit 15 (run).
10	active	RU	The TSB12LV23A device sets this bit to 1 when it is processing descriptors.
9–8	RSVD	R	Reserved. Bits 9–8 return 0s when read.
7–5	spd	RU	This field indicates the speed at which a packet was received or transmitted, and only contains meaningful information for receive contexts. This field is encoded as: 000 = 100 Mbits/sec 001 = 200 Mbits/sec 010 = 400 Mbits/sec All other values are reserved.
4–0	eventcode	RU	This field holds the acknowledge sent by the link core for this packet, or holds an internally generated error code if the packet was not transferred successfully.

4.38 Asynchronous Context Command Pointer Register

The asynchronous context command pointer register contains a pointer to the address of the first descriptor block that the TSB12LV23A device accesses when software enables the context by setting bit 15 (run) of the asynchronous context control register (see Section 4.37). See Table 4–28 for a complete description of the register contents.

Bit	31	30	29	28	27	26	25	24	23	22	21	20	19	18	17	16
Name	Asynchronous context command pointer															
Type	RWU	RWU	RWU	RWU	RWU	RWU	RWU	RWU	RWU	RWU	RWU	RWU	RWU	RWU	RWU	RWU
Default	X	X	X	X	X	X	X	X	X	X	X	X	X	X	X	X
Bit	15	14	13	12	11	10	9	8	7	6	5	4	3	2	1	0
Name	Asynchronous context command pointer															
Type	RWU	RWU	RWU	RWU	RWU	RWU	RWU	RWU	RWU	RWU	RWU	RWU	RWU	RWU	RWU	RWU
Default	X	X	X	X	X	X	X	X	X	X	X	X	X	X	X	X

Register: **Asynchronous context command pointer**
 Type: Read/Write/Update
 Offset: 18Ch [ATRQ]
 1ACh [ATRS]
 1CCh [ARRQ]
 1ECh [ARRS]
 Default: XXXX XXXXh

Table 4–28. Asynchronous Context Command Pointer Register Description

BIT	FIELD NAME	TYPE	DESCRIPTION
31–4	descriptorAddress	RWU	Contains the upper 28 bits of the address of a 16-byte-aligned descriptor block.
3–0	Z	RWU	Indicates the number of contiguous descriptors at the address pointed to by the descriptor address. If Z is 0, then it indicates that the descriptorAddress field (bits 31–4) is not valid.

4.39 Isochronous Transmit Context Control Register

The isochronous transmit context control set/clear register controls options, state, and status for the isochronous transmit DMA contexts. The n value in the following register addresses indicates the context number (n = 0, 1, 2, 3, ..., 7). See Table 4–29 for a complete description of the register contents.

Bit	31	30	29	28	27	26	25	24	23	22	21	20	19	18	17	16
Name	Isochronous transmit context control															
Type	RSCU	RSC	RSC	RSC	RSC	RSC	RSC	RSC	RSC	RSC	RSC	RSC	RSC	RSC	RSC	RSC
Default	X	X	X	X	X	X	X	X	X	X	X	X	X	X	X	X
Bit	15	14	13	12	11	10	9	8	7	6	5	4	3	2	1	0
Name	Isochronous transmit context control															
Type	RSC	R	R	RSU	RU	RU	R	R	RU	RU	RU	RU	RU	RU	RU	RU
Default	0	0	0	X	0	0	0	0	X	X	X	X	X	X	X	X

Register: **Isochronous transmit context control**
 Type: Read/Set/Clear/Update, Read/Set/Clear, Read/Update, Read-only
 Offset: 200h + (16 * n) set register
 204h + (16 * n) clear register
 Default: XXXX X0XXh

Table 4–29. Isochronous Transmit Context Control Register Description

BIT	FIELD NAME	TYPE	DESCRIPTION
31	cycleMatchEnable	RSCU	When this bit is set to 1, processing occurs such that the packet described by the context first descriptor block is transmitted in the cycle whose number is specified in the cycleMatch field (bits 30–16). The cycleMatch field (bits 30–16) must match the low-order two bits of cycleSeconds and the 13-bit cycleCount field in the cycle start packet that is sent or received immediately before isochronous transmission begins. Since the isochronous transmit DMA controller may work ahead, the processing of the first descriptor block may begin slightly in advance of the actual cycle in which the first packet is transmitted. The effects of this bit, however, are impacted by the values of other bits in this register and are explained in the <i>1394 Open Host Controller Interface Specification</i> . Once the context has become active, hardware clears this bit.
30–16	cycleMatch	RSC	This field contains a 15-bit value, corresponding to the low-order two bits of the isochronous cycle timer register (OHCI offset F0h, see Section 4.31) cycleSeconds field (bits 31–25) and the cycleCount field (bits 24–12). If bit 31 (cycleMatchEnable) is set, then this isochronous transmit DMA context becomes enabled for transmits when the low-order two bits of the isochronous cycle timer register cycleSeconds field (bits 31–25) and the cycleCount field (bits 24–12) value equal this field (cycleMatch) value.
15	run	RSC	This bit is set by software to enable descriptor processing for the context and cleared by software to stop descriptor processing. The TSB12LV23A device changes this bit only on a hardware or software reset.
14–13	RSVD	R	Reserved. Bits 14–13 return 0s when read.
12	wake	RSU	Software sets this bit to cause the TSB12LV23A device to continue or resume descriptor processing. The TSB12LV23A device clears this bit on every descriptor fetch.
11	dead	RU	The TSB12LV23A device sets this bit when it encounters a fatal error and clears the bit when software resets bit 15 (run).
10	active	RU	The TSB12LV23A device sets this bit to 1 when it is processing descriptors.
9–8	RSVD	R	Reserved. Bits 9–8 return 0s when read.
7–5	spd	RU	This field is not meaningful for isochronous transmit contexts.
4–0	event code	RU	Following an OUTPUT_LAST* command, the error code is indicated in this field. Possible values are: ack_complete, evt_descriptor_read, evt_data_read, and evt_unknown.

4.40 Isochronous Transmit Context Command Pointer Register

The isochronous transmit context command pointer register contains a pointer to the address of the first descriptor block that the TSB12LV23A device accesses when software enables an isochronous transmit context by setting bit 15 (run) of the isochronous transmit context control register (see Section 4.39). The n value in the following register addresses indicates the context number (n = 0, 1, 2, 3, ..., 7).

Bit	31	30	29	28	27	26	25	24	23	22	21	20	19	18	17	16
Name	Isochronous transmit context command pointer															
Type	R	R	R	R	R	R	R	R	R	R	R	R	R	R	R	R
Default	X	X	X	X	X	X	X	X	X	X	X	X	X	X	X	X
Bit	15	14	13	12	11	10	9	8	7	6	5	4	3	2	1	0
Name	Isochronous transmit context command pointer															
Type	R	R	R	R	R	R	R	R	R	R	R	R	R	R	R	R
Default	X	X	X	X	X	X	X	X	X	X	X	X	X	X	X	X

Register: **Isochronous transmit context command pointer**
 Type: Read-only
 Offset: 20Ch + (16 * n)
 Default: XXXX XXXXh

4.41 Isochronous Receive Context Control Register

The isochronous receive context control set/clear register controls options, state, and status for the isochronous receive DMA contexts. The n value in the following register addresses indicates the context number (n = 0, 1, 2, 3). See Table 4–30 for a complete description of the register contents.

Bit	31	30	29	28	27	26	25	24	23	22	21	20	19	18	17	16
Name	Isochronous receive context control															
Type	RSC	RSC	RSCU	RSC	R	R	R	R	R	R	R	R	R	R	R	R
Default	X	X	X	X	0	0	0	0	0	0	0	0	0	0	0	0
Bit	15	14	13	12	11	10	9	8	7	6	5	4	3	2	1	0
Name	Isochronous receive context control															
Type	RSCU	R	R	RSU	RU	RU	R	R	RU	RU	RU	RU	RU	RU	RU	RU
Default	0	0	0	X	0	0	0	0	X	X	X	X	X	X	X	X

Register: **Isochronous receive context control**
 Type: Read/Set/Clear/Update, Read/Set/Clear, Read/Set/Update, Read/Update, Read-only
 Offset: 400h + (32 * n) set register
 404h + (32 * n) clear register
 Default: X000 X0XXh

Table 4–30. Isochronous Receive Context Control Register Description

BIT	FIELD NAME	TYPE	DESCRIPTION
31	bufferFill	RSC	When this bit is set, received packets are placed back-to-back to completely fill each receive buffer. When this bit is cleared, each received packet is placed in a single buffer. If bit 28 (multiChanMode) is set to 1, then this bit must also be set to 1. The value of this bit must not be changed while bit 10 (active) or bit 15 (run) is set.
30	isochHeader	RSC	When this bit is 1, received isochronous packets include the complete 4-byte isochronous packet header seen by the link layer. The end of the packet is marked with xferStatus in the first doublet, and a 16-bit timeStamp indicating the time of the most recently received (or sent) cycleStart packet. When this bit is cleared, the packet header is stripped from received isochronous packets. The packet header, if received, immediately precedes the packet payload. The value of this bit must not be changed while bit 10 (active) or bit 15 (run) is set.

Table 4–30. Isochronous Receive Context Control Register Description (Continued)

BIT	FIELD NAME	TYPE	DESCRIPTION
29	cycleMatchEnable	RSCU	When this bit is set, the context begins running only when the 13-bit cycleMatch field (bits 24–12) in the isochronous receive context match register (see Section 4.43) matches the 13-bit cycleCount field in the cycleStart packet. The effects of this bit, however, are impacted by the values of other bits in this register. When the context has become active, hardware clears this bit. The value of this bit must not be changed while bit 10 (active) or bit 15 (run) is set.
28	multiChanMode	RSC	When this bit is set, the corresponding isochronous receive DMA context receives packets for all isochronous channels enabled in the isochronous receive channel mask high (OHCI offset 70h/74h, see Section 4.19) and isochronous receive channel mask low (OHCI offset 78h/7Ch, see Section 4.20) registers. The isochronous channel number specified in the isochronous receive context match register (see Section 4.43) is ignored. When this bit is cleared, the isochronous receive DMA context receives packets for the single channel specified in the isochronous receive context match register (see Section 4.43). Only one isochronous receive DMA context may use the isochronous receive channel mask registers (see Sections 4.19 and 4.20). If more than one isochronous receive context control register has this bit set, then results are undefined. The value of this bit must not be changed while bit 10 (active) or bit 15 (run) is set to 1.
27–16	RSVD	R	Reserved. Bits 27–16 return 0s when read.
15	run	RSCU	This bit is set by software to enable descriptor processing for the context and cleared by software to stop descriptor processing. The TSB12LV23A device changes this bit only on a hardware or software reset.
14–13	RSVD	R	Reserved. Bits 14–13 return 0s when read.
12	wake	RSU	Software sets this bit to cause the TSB12LV23A device to continue or resume descriptor processing. The TSB12LV23A device clears this bit on every descriptor fetch.
11	dead	RU	The TSB12LV23A device sets this bit when it encounters a fatal error and clears the bit when software resets bit 15 (run).
10	active	RU	The TSB12LV23A device sets this bit to 1 when it is processing descriptors.
9–8	RSVD	R	Reserved. Bits 9–8 return 0s when read.
7–5	spd	RU	This field indicates the speed at which the packet was received. 000 = 100 Mbits/sec 001 = 200 Mbits/sec 010 = 400 Mbits/sec All other values are reserved.
4–0	event code	RU	For bufferFill mode, possible values are: ack_complete, evt_descriptor_read, evt_data_write, and evt_unknown. Packets with data errors (either dataLength mismatches or dataCRC errors) and packets for which a FIFO overrun occurred are backed out. For packet-per-buffer mode, possible values are: ack_complete, ack_data_error, evt_long_packet, evt_overrun, evt_descriptor_read, evt_data_write, and evt_unknown.

4.42 Isochronous Receive Context Command Pointer Register

The isochronous receive context command pointer register contains a pointer to the address of the first descriptor block that the TSB12LV23A device accesses when software enables an isochronous receive context by setting bit 15 (run) in the isochronous receive context control register (see Section 4.41). The n value in the following register addresses indicates the context number (n = 0, 1, 2, 3).

Bit	31	30	29	28	27	26	25	24	23	22	21	20	19	18	17	16
Name	Isochronous receive context command pointer															
Type	R	R	R	R	R	R	R	R	R	R	R	R	R	R	R	R
Default	X	X	X	X	X	X	X	X	X	X	X	X	X	X	X	X
Bit	15	14	13	12	11	10	9	8	7	6	5	4	3	2	1	0
Name	Isochronous receive context command pointer															
Type	R	R	R	R	R	R	R	R	R	R	R	R	R	R	R	R
Default	X	X	X	X	X	X	X	X	X	X	X	X	X	X	X	X

Register: **Isochronous receive context command pointer**
 Type: Read-only
 Offset: 40Ch + (32 * n)
 Default: XXXX XXXXh

4.43 Isochronous Receive Context Match Register

The isochronous receive context match register is used to start an isochronous receive context running on a specified cycle number, to filter incoming isochronous packets based on tag values, and to wait for packets with a specified sync value. The n value in the following register addresses indicates the context number (n = 0, 1, 2, 3). See Table 4–31 for a complete description of the register contents.

Bit	31	30	29	28	27	26	25	24	23	22	21	20	19	18	17	16
Name	Isochronous receive context match															
Type	R/W	R/W	R/W	R/W	R	R	R	R/W	R/W	R/W	R/W	R/W	R/W	R/W	R/W	R/W
Default	X	X	X	X	0	0	0	X	X	X	X	X	X	X	X	X
Bit	15	14	13	12	11	10	9	8	7	6	5	4	3	2	1	0
Name	Isochronous receive context match															
Type	R/W	R/W	R/W	R/W	R/W	R/W	R/W	R/W	R	R/W	R/W	R/W	R/W	R/W	R/W	R/W
Default	X	X	X	X	X	X	X	X	0	X	X	X	X	X	X	X

Register: **Isochronous receive context match**
 Type: Read/Write, Read-only
 Offset: 410Ch + (32 * n)
 Default: XXXX XXXXh

Table 4–31. Isochronous Receive Context Match Register Description

BIT	FIELD NAME	TYPE	DESCRIPTION
31	tag3	R/W	If this bit is set, then this context matches on iso receive packets with a tag field of 11b.
30	tag2	R/W	If this bit is set, then this context matches on iso receive packets with a tag field of 10b.
29	tag1	R/W	If this bit is set, then this context matches on iso receive packets with a tag field of 01b.
28	tag0	R/W	If this bit is set, then this context matches on iso receive packets with a tag field of 00b.
27–25	RSVD	R	Reserved. Bits 27–25 return 0s when read.
24–12	cycleMatch	R/W	This field contains a 15-bit value corresponding to the two low-order two bits of cycleSeconds and the 13-bit cycleCount field in the cycleStart packet. If bit 29 (cycleMatchEnable) of the isochronous receive context control register (see Section 4.41) is set, then this context is enabled for receives when the two low-order bits of the isochronous cycle timer register (OHCI offset F0h, see Section 4.31) cycleSeconds field (bits 31–25) and cycleCount field (bits 24–12) value equal this field (cycleMatch) value.
11–8	sync	R/W	This field contains the four-bit field which is compared to the sync field of each iso packet for this channel when the command descriptor w field is set to 11b.
7	RSVD	R	Reserved. Bit 7 returns 0 when read.
6	tag1SyncFilter	R/W	If this bit and bit 29 (tag1) are set, then packets with tag 01b are accepted into the context if the two most significant bits of the packet sync field are 00b. Packets with tag values other than 01b are filtered according to tag0, tag2, and tag3 (bits 28, 30, and 31, respectively) without any additional restrictions. If this bit is cleared, then this context matches on isochronous receive packets as specified in bits 28–31 (tag0–tag3) with no additional restrictions.
5–0	channelNumber	R/W	This 6-bit field indicates the isochronous channel number for which this isochronous receive DMA context accepts packets.

4.44 IR Digital Video Enhancements Register

This register is used to enable the DV enhancements in the TSB12LV23A device. The bits in this register may only be modified when both the active and run bits of the corresponding context control register are 0. See Table 4–32 for a complete description of the register contents.

Bit	31	30	29	28	27	26	25	24	23	22	21	20	19	18	17	16
Name	IR digital video enhancements															
Type	R	R	R	R	R	R	R	R	R	R	R	R	R	R	R	R
Default	0	0	0	0	0	0	0	0	0	0	0	0	0	0	0	0
Bit	15	14	13	12	11	10	9	8	7	6	5	4	3	2	1	0
Name	IR digital video enhancements															
Type	R	R	RSC	RSC	R	R	RSC	RSC	R	R	RSC	RSC	R	R	RSC	RSC
Default	0	0	0	0	0	0	0	0	0	0	0	0	0	0	0	0

Register: **IR digital video enhancements**
 Type: Read/Set/Clear, Read-only
 Offset: A88h set register
 A8Ch clear register
 Default: 0000 0000h

Table 4–32. IR Digital Video Enhancements Register Description

BIT	FIELD NAME	TYPE	DESCRIPTION
31–14	RSVD	R	Reserved. Bits 31–14 return 0s when read.
13	DV_Branch3	RSC	When set, this bit will cause isochronous receive context 3 in bufferfill mode to sync reception to the DV frame start tag when input_more.b = 01b, and will jump to the descriptor pointed to by frameBranch if a DV frame start tag is received out of place. This bit is only interpreted when bit 12 (CIP_Strip3) is 1 and bit 30 (isochHeader) of the isochronous receive context control register (OHCI offset 460h/464h, see Section 4.41) is 0.
12	CIP_Strip3	RSC	When set, this bit will cause isochronous receive context 3 to strip the first two quadlets of payload. This bit is only interpreted when bit 30 (isochHeader) of the isochronous receive context control register (OHCI offset 460h/464h, see Section 4.41) is 0.
11–10	RSVD	R	Reserved. Bits 11–10 return 0s when read.
9	DV_Branch2	RSC	When set, this bit will cause isochronous receive context 2 in bufferfill mode to sync reception to the DV frame start tag when input_more.b = 01b, and will jump to the descriptor pointed to by frameBranch if a DV frame start tag is received out of place. This bit is only interpreted when bit 8 (CIP_Strip2) is 1 and bit 30 (isochHeader) of the isochronous receive context control register (OHCI offset 440h/444h, see Section 4.41) is 0.
8	CIP_Strip2	RSC	When set, this bit will cause isochronous receive context 2 to strip the first two quadlets of payload. This bit is only interpreted when bit 30 (isochHeader) of the isochronous receive context control register (OHCI offset 440h/444h, see Section 4.41) is 0.
7–6	RSVD	R	Reserved. Bits 7–6 return 0s when read.
5	DV_Branch1	RSC	When set, this bit will cause isochronous receive context 1 in bufferfill mode to sync reception to the DV frame start tag when input_more.b = 01b, and will jump to the descriptor pointed to by frameBranch if a DV frame start tag is received out of place. This bit is only interpreted when bit 4 (CIP_Strip1) is 1 and bit 30 (isochHeader) of the isochronous receive context control register (OHCI offset 420h/424h, see Section 4.41) is 0.
4	CIP_Strip1	RSC	When set, this bit will cause isochronous receive context 1 to strip the first two quadlets of payload. This bit is only interpreted when bit 30 (isochHeader) of the isochronous receive context control register (OHCI offset 420h/424h, see Section 4.41) is 0.
3–2	RSVD	R	Reserved. Bits 3–2 return 0s when read.

Table 4–32. IR Digital Video Enhancements Register Description (Continued)

BIT	FIELD NAME	TYPE	DESCRIPTION
1	DV_Branch0	RSC	When set, this bit will cause isochronous receive context 0 in bufferfill mode to sync reception to the DV frame start tag when input_more.b = 01b, and will jump to the descriptor pointed to by frameBranch if a DV frame start tag is received out of place. This bit is only interpreted when bit 0 (CIP_Strip0) is 1 and bit 30 (isochHeader) of the isochronous receive context control register (OHCI offset 400h/404h, see Section 4.41) is 0.
0	CIP_Strip0	RSC	When set, this bit will cause isochronous receive context 0 to strip the first two quadlets of payload. This bit is only interpreted when bit 30 (isochHeader) of the isochronous receive context control register (OHCI offset 400h/404h, see Section 4.41) is 0.

6 Serial ROM Interface

The TSB12LV23A device provides a serial bus interface to initialize the 1394 global unique ID register and a few PCI configuration registers through a serial ROM. The TSB12LV23A device communicates with the serial ROM via the 2-wire serial interface.

After powerup, the serial interface initializes the locations listed in Table 6–1. While the TSB12LV23A device is accessing the serial ROM, all incoming PCI slave accesses are terminated with retry status. Table 6–2 shows the serial ROM memory map required for initializing the TSB12LV23A registers.

NOTE: If a ROM is implemented in the design, it must be programmed. An unprogrammed ROM defaults to all 1s, which will adversely impact device operation.

Table 6–1. Registers and Bits Loadable Through Serial ROM

ROM OFFSET	PCI/OHCI OFFSET	REGISTER	BITS LOADED FROM ROM
00h	PCI register (3Eh)	PCI maximum latency, PCI minimum grant	15–0
01h	PCI register (2Dh)	Vendor identification	15–0
03h	PCI register (2Ch)	Subsystem identification	15–0
05h (bit 6)	OHCI register (50h)	Host controller control	23
05h	PCI register (F4h)	Link enhancement control	7, 2, 1
06h–0Ah	OHCI register (24h)	GUID high	31–0
0Bh–0Eh	OHCI register(28h)	GUID low	31–0
10h	PCI register (F4h)	Link enhancement control	13, 12, 9, 8
11h–12h	PCI register (F0h)	Miscellaneous configuration	15, 13, 10, 4–0
13h	PCI register (40h)	OHCI control	0

Table 6–2. Serial ROM Map

BYTE ADDRESS	BYTE DESCRIPTION							
00	PCI maximum latency (0h)				PCI minimum grant (0h)			
01	PCI vendor ID							
02	PCI vendor ID (msbyte)							
03	PCI subsystem ID (lsbyte)							
04	PCI subsystem ID							
05	[7] Link_enhancement- Control.enab_unfair	[6] HCControl. ProgramPhy Enable	[5] RSVD	[4] RSVD	[3] RSVD	[2] Link_enhancement- Control.enab_ insert_idle	[1] Link_enhancement- Control.enab_accel	[0] RSVD
06	Mini ROM address							
07	GUID high (lsbyte 0)							
08	GUID high (byte 1)							
09	GUID high (byte 2)							
0A	GUID high (msbyte 3)							
0B	GUID low (lsbyte 0)							
0C	GUID low (byte 1)							
0D	GUID low (byte 2)							
0E	GUID low (msbyte 3)							
0F	Checksum							
10	[15] RSVD	[14] RSVD	[13–12] AT threshold		[11] RSVD	[10] RSVD	[9] Enable audio time stamp	[8] Enable DV CIP time stamp
11	[7] RSVD	[6] RSVD	[5] RSVD	[4] Disable Target Abort	[3] GP2IIC	[2] Disable SCLK gate	[1] Disable PCI gate	[0] Keep PCI
12	[15] PME D3 Cold	[14] RSVD	[13] PME Support D2	[12] RSVD	[11] RSVD	[10] D2 support	[9] RSVD	[8] RSVD
13	[7] RSVD	[6] RSVD	[5] RSVD	[4] RSVD	[3] RSVD	[2] RSVD	[1] RSVD	[0] Global swap
14	CIS offset address							
15–1E	RSVD							
1F	RSVD							

7 Electrical Characteristics

7.1 Absolute Maximum Ratings Over Operating Temperature Ranges†

Supply voltage range, V_{CC}	-0.5 V to 3.6 V
Supply voltage range, V_{CCP}	-0.5 V to 5.5 V
Input voltage range for PCI, V_I	-0.5 to $V_{CCP} + 0.5$ V
Input voltage range for Miscellaneous and PHY interface, V_I	-0.5 to $V_{CCI} + 0.5$ V
Output voltage range for PCI, V_O	-0.5 to $V_{CCP} + 0.5$ V
Input voltage range for Miscellaneous and PHY interface, V_O	-0.5 to $V_{CCP} + 0.5$ V
Input clamp current, I_{IK} ($V_I < 0$ or $V_I > V_{CC}$) (see Note 1)	± 20 mA
Output clamp current, I_{OK} ($V_O < 0$ or $V_O > V_{CC}$) (see Note 2)	± 20 mA
Storage temperature range	-65°C to 150°C

† Stresses beyond those listed under absolute maximum ratings may cause permanent damage to the device. These are stress ratings only, and functional operation of the device at these or any other conditions beyond those indicated under recommended operating conditions is not implied. Exposure to absolute-maximum-rated conditions for extended periods may affect device reliability.

- NOTES: 1. Applies to external input and bidirectional buffers. For 5-V tolerant use $V_I > V_{CC}$. For PCI use $V_I > V_{CCP}$.
2. Applies to external output and bidirectional buffers. For 5-V tolerant use $V_O > V_{CC}$. For PCI use $V_O > V_{CCP}$.

7.2 Recommended Operating Conditions

			OPERATION	MIN	NOM	MAX	UNIT
V _{CC}	Core voltage	Commercial	3.3 V	3	3.3	3.6	V
V _{CCP}	PCI I/O clamping voltage	Commercial	3.3 V	3	3.3	3.6	V
			5 V	4.5	5	5.5	
V _{IH} [†]	High-level input voltage	PCI	3.3 V	0.475 V _{CCP}		V _{CCP}	V
			5 V	2		V _{CCP}	
		PHY interface		2		V _{CC}	
		Miscellaneous [‡]		2		V _{CC}	
V _{IL} [†]	Low-level input voltage	PCI	3.3 V	0		0.325 V _{CCP}	V
			5 V	0		0.8	
		PHY interface		0		0.8	
		Miscellaneous [‡]		0		0.8	
V _I	Input voltage	PCI	3.3 V	0		V _{CCP}	V
		PHY interface		0		V _{CCP}	
		Miscellaneous [‡]		0		V _{CCP}	
V _O [§]	Output voltage	PCI	3.3 V	0		V _{CCP}	V
		PHY interface		0		V _{CCP}	
		Miscellaneous [‡]		0		V _{CCP}	
t _t	Input transition time (t _r and t _f)	PCI		0		6	ns
T _A	Operating ambient temperature			0	25	70	°C
T _J [¶]	Virtual junction temperature			0	25	115	°C

[†] Applies to external inputs and bidirectional buffers without hysteresis.

[‡] Miscellaneous pins are: GPIO2, GPIO3, SDA, SCL, CYCLEOUT.

[§] Applies to external output buffers.

[¶] The junction temperatures reflect simulation conditions. Customer is responsible for verifying junction temperature.

7.3 Electrical Characteristics Over Recommended Operating Conditions (unless otherwise noted)

		OPERATION	TEST CONDITIONS	MIN	MAX	UNIT
V_{OH}	High-level output voltage	PCI	$I_{OH} = -0.5 \text{ mA}$	0.9 V_{CC}		V
			$I_{OH} = -2 \text{ mA}$	2.4		
	PHY interface	$I_{OH} = -4 \mu\text{A}$	2.8			
		$I_{OH} = -8 \text{ mA}$	$V_{CC} - 0.6$			
Miscellaneous [‡]	$I_{OH} = -4 \text{ mA}$	$V_{CC} - 0.6$				
V_{OL}^{\dagger}	Low-level output voltage	PCI	$I_{OL} = 1.5 \text{ mA}$	0.1 V_{CC}		V
			$I_{OL} = 6 \text{ mA}$	0	0.55	
		PHY interface	$I_{OL} = 4 \text{ mA}$	0.4		
			$I_{OL} = 8 \text{ mA}$			
Miscellaneous [‡]	$I_{OL} = 4 \text{ mA}$	0.5				
I_{OZ}	3-state output high-impedance	Output pins	3.6 V	$V_O = V_{CC}$ or GND	± 20	μA
I_{IL}	Low-level input current	Input pins	3.6 V	$V_I = \text{GND}^{\dagger}$	± 20	μA
		I/O pins [†]	3.6 V	$V_I = \text{GND}^{\dagger}$	± 20	
I_{IH}	High-level input current	PCI [†]	3.6 V	$V_I = V_{CC}^{\dagger}$	± 20	μA
		Others [†]	3.6 V	$V_I = V_{CC}^{\dagger}$	± 20	

[†] For I/O pins, input leakage (I_{IL} and I_{IH}) includes I_{OZ} of the disabled output.

[‡] Miscellaneous pins are: GPIO2, GPIO3, SDA, SCL, CYCLEOUT.

7.4 Switching Characteristics for PCI Interface[§]

PARAMETER		MEASURED	MIN	TYP	MAX	UNIT
t_{su}	Setup time before PCLK	-50% to 50%	7			ns
t_h	Hold time before PCLK	-50% to 50%	0			ns
t_d	Delay time, PHY_CLK to data valid	-50% to 50%	2		11	ns

[§] These parameters are ensured by design.

7.5 Switching Characteristics for PHY-Link Interface[§]

PARAMETER		MEASURED	MIN	TYP	MAX	UNIT
t_{su}	Setup time, Dn, CTLn, LREQ to PHY_CLK	-50% to 50%	6			ns
t_h	Hold time, Dn, CTLn, LREQ before PHY_CLK	-50% to 50%	0			ns
t_d	Delay time, PHY_CLK to Dn, CTLn	-50% to 50%	1		10	ns

[§] These parameters are ensured by design.

8 Mechanical Information

The TSB12LV23A device is packaged in a 100-terminal PZ package. The following shows the mechanical dimensions for the PZ package.

PZ (S-PQFP-G100)

PLASTIC QUAD FLATPACK

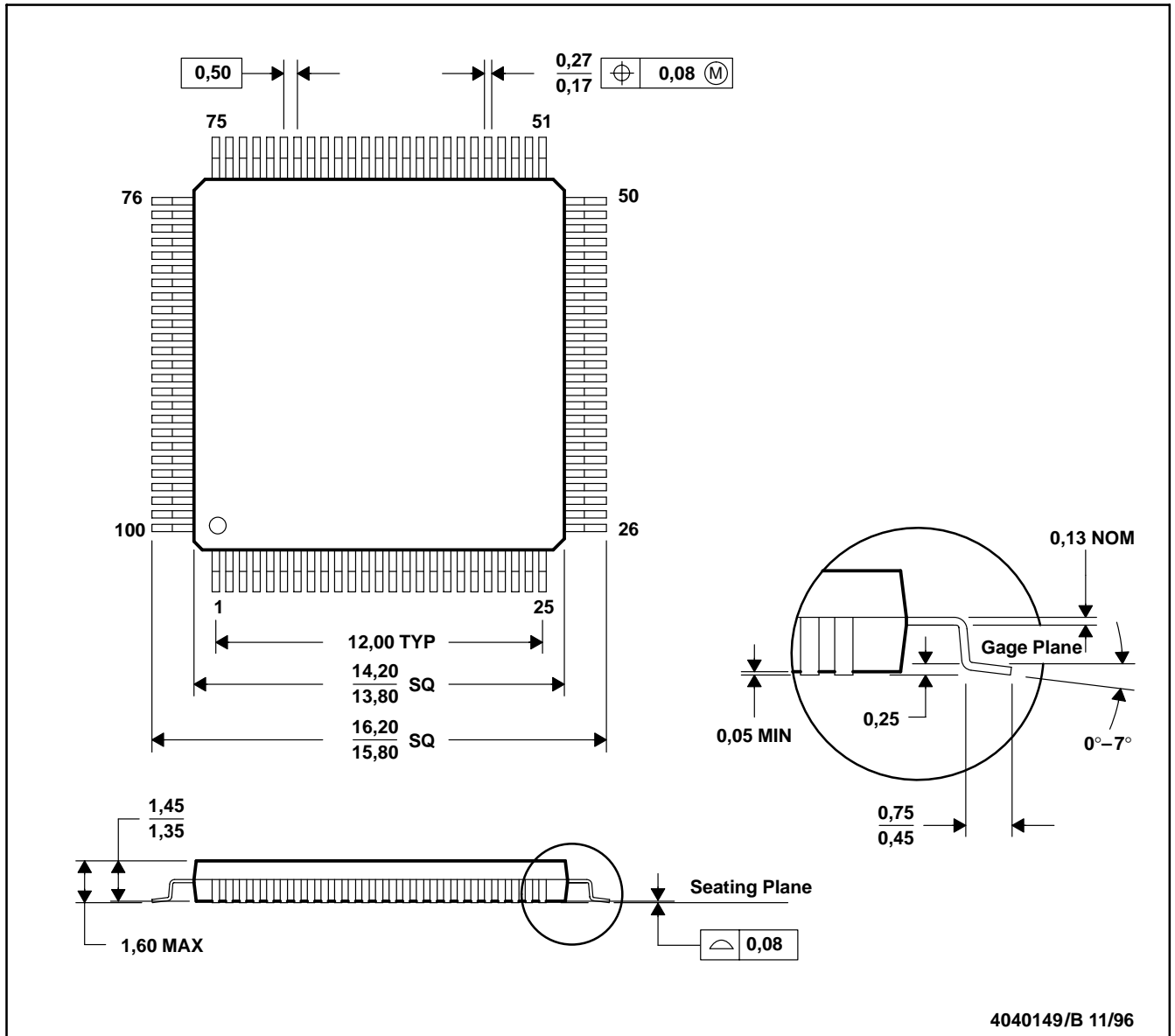

- NOTES: A. All linear dimensions are in millimeters.
 B. This drawing is subject to change without notice.
 C. Falls within JEDEC MO-136

PZT (S-PQFP-G100)

PLASTIC QUAD FLATPACK

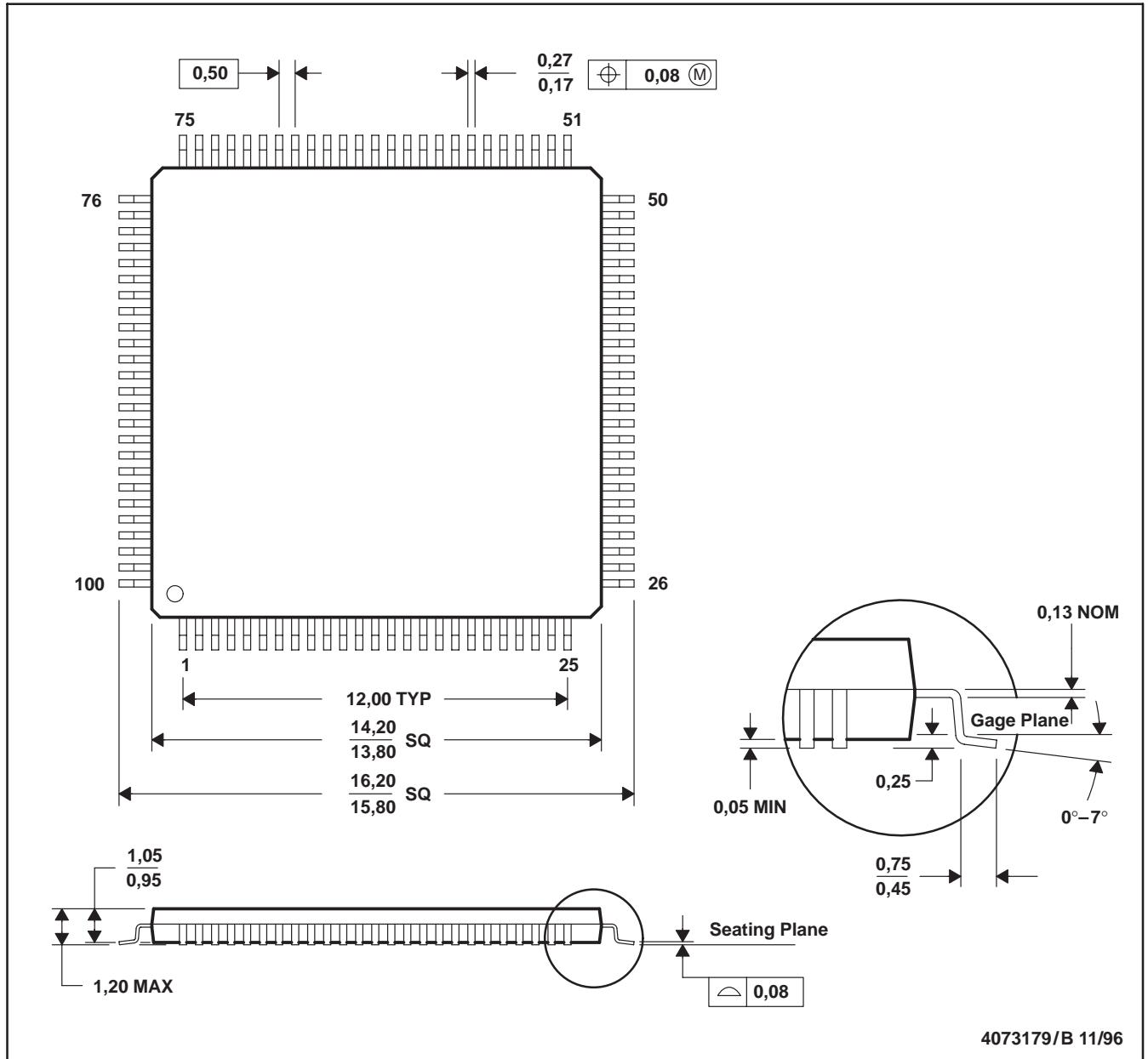

- NOTES: A. All linear dimensions are in millimeters.
 B. This drawing is subject to change without notice.
 C. Falls within JEDEC MS-026