

February 1985

OBJECTIVE  
SPECIFICATIONS

## Quad 2-Input Exclusive-OR Gates

### Features

- **Function, pin-out, speed and drive compatibility with 54/74LS logic family**
- **Low power consumption characteristic of CMOS**
- **High-Drive-Current outputs:**  
 $I_{OL} = 8 \text{ mA} @ V_{OL} = 0.5\text{V}$
- **Inputs and outputs interface directly with TTL, NMOS and CMOS devices**
- **Wide operating voltage range: 4.5V to 5.5V**
- **Characterized for operation over industrial and military temperature ranges:**  
74HCTLS:  $-40^{\circ}\text{C}$  to  $+85^{\circ}\text{C}$   
54HCTLS:  $-55^{\circ}\text{C}$  to  $+125^{\circ}\text{C}$

### Description

These devices contain four independent 2-input Exclusive-OR gates. They perform the Boolean functions  $Y = A \oplus B = \bar{A}B + A\bar{B}$ .

Fabricated using Zytrex's proprietary ICE-MOS process, these devices provide speeds and drive capability equivalent to their LSTTL counterparts and yet maintain CMOS power levels. The input and output voltage levels allow direct interface with TTL, NMOS and CMOS devices without any external components.

All inputs and outputs are protected from damage due to static discharge by internal diode clamps to  $V_{CC}$  and ground.

### Pin Configuration

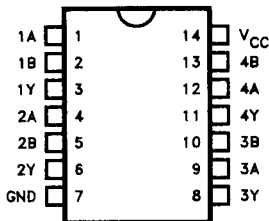

0076-1

### Logic Diagram

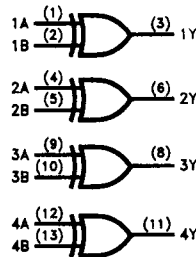

0076-2

### Function Table

(Each Gate)

Inputs		Output
A	B	Y
L	L	L
L	H	H
H	L	H
H	H	L

## Absolute Maximum Ratings\*

Supply Voltage Range,  $V_{CC}$  ..... -0.5V to 7V  
 DC Input Diode Current,  $I_{IK}$   
 ( $V_I < -0.5V$  or  $V_I > V_{CC} + 0.5V$ ) .....  $\pm 20$  mA  
 DC Output Diode Current,  $I_{OK}$   
 ( $V_O < -0.5V$  or  $V_O > V_{CC} + 0.5V$ ) .....  $\pm 20$  mA  
 Continuous Output Current Per Pin,  $I_O$   
 ( $-0.5V < V_O < V_{CC} + 0.5V$ ) .....  $\pm 35$  mA  
 Continuous Current Through  
 $V_{CC}$  or GND pins .....  $\pm 125$  mA  
 Storage Temperature Range,  $T_{STG}$  .. -65°C to +150°C  
 Power Dissipation Per Package,  $P_D$ † ..... 500 mW

\*Absolute Maximum Ratings are those values beyond which permanent damage to the device may occur. These are stress ratings only and functional operation of the device at or beyond them is not implied. Long exposure to these conditions may affect device reliability.

† Power Dissipation temperature derating:  
 Plastic Package (N): -12 mW/°C from 65°C to 85°C  
 Ceramic Package (J): -12 mW/°C from 100°C to 125°C

## Recommended Operating Conditions

Supply Voltage,  $V_{CC}$  ..... 4.5V to 5.5V  
 DC Input & Output Voltages\*,  $V_{IN}$ ,  $V_{OUT}$  ..... 0V to  $V_{CC}$   
 Operating Temperature  
 Range ZX74HCTL5: -40°C to +85°C  
 ZX54HCTL5: -55°C to +125°C  
 Input Rise & Fall Times,  $t_r$ ,  $t_f$  ..... Max 500 ns

\*Unused inputs must always be tied to an appropriate logic voltage level (either  $V_{CC}$  or GND)

## DC Electrical Characteristics ( $V_{CC} = 5V \pm 10\%$ Unless Otherwise Specified)

Symbol	Parameter	Test Conditions	$T_A = 25^\circ C$		74HCTL5	54HCTL5	Unit
			Typ	Guaranteed Limits			
$V_{IH}$	Minimum High-Level Input Voltage			2.0	2.0	2.0	V
$V_{IL}$	Maximum Low-Level Input Voltage			0.8	0.8	0.8	V
$V_{OH}$	Minimum High-Level Output Voltage	$V_{IN} = V_{IH}$ or $V_{IL}$ $I_O = -20 \mu A$ $I_O = -4$ mA	$V_{CC}$ 4.2	$V_{CC} - 0.1$ 3.98	$V_{CC} - 0.1$ 3.84	$V_{CC} - 0.1$ 3.7	V
$V_{OL}$	Maximum Low-Level Output Voltage	$V_{IN} = V_{IH}$ or $V_{IL}$ $I_O = 20 \mu A$ $I_O = 4$ mA $I_O = 8$ mA	0	0.1 0.26 0.39	0.1 0.33 0.5	0.1 0.4	V
$I_{IN}$	Maximum Input Current	$V_{IN} = V_{CC}$ or GND		$\pm 0.1$	$\pm 1.0$	$\pm 1.0$	$\mu A$
$I_{CC}$	Maximum Quiescent Supply Current	$V_{IN} = V_{CC}$ or GND $I_{OUT} = 0 \mu A$		2.0	20.0	40.0	$\mu A$

## AC Electrical Characteristics (Input $t_r$ , $t_f \leq 6$ ns), HCTL586

Symbol	Parameter	Conditions†	$T_A = 25^\circ C$ $V_{CC} = 5.0V$		74HCTL5	54HCTL5	Unit
			Typ	Guaranteed Limits			
$t_{PLH}$	Maximum Propagation Delay, A or B to Y (Other Input Low)	$C_L = 50$ pF	15	20	25	30	ns
$t_{PHL}$			15	20	25	30	
$t_{PLH}$	Maximum Propagation Delay, A or B to Y (Other Input High)		18	25	31	37	ns
$t_{PHL}$			18	25	31	37	
$C_{IN}$	Maximum Input Capacitance		5				pF
$C_{PD}$	Power Dissipation Capacitance* (per gate)		15				pF

\* $C_{PD}$  determines the no-load dynamic power dissipation:  $P_D = C_{PD} V_{CC}^2 f + I_{CC} V_{CC}$ .

†For AC switching test circuits and timing waveforms see section 2.

14-Pin Packages

Plastic Package

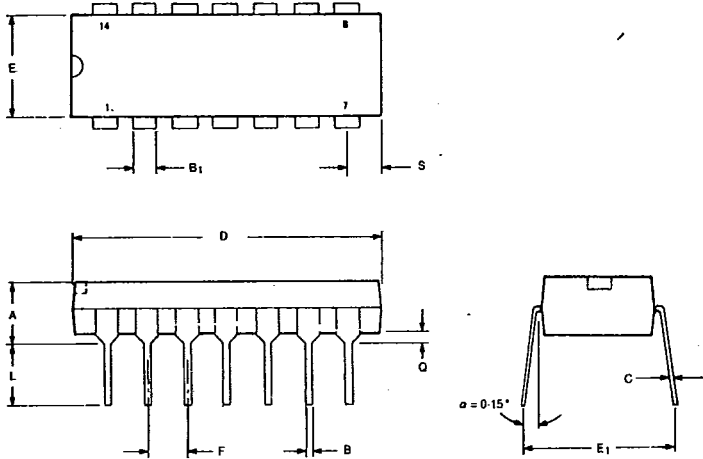

DIM	Millimeters		Inches	
	Min	Max	Min	Max
A	3.81	5.08	0.150	0.200
B	0.38	0.58	0.015	0.023
B <sub>1</sub>	1.40	1.78	0.055	0.070
C	0.20	0.38	0.008	0.015
D	18.16	19.56	0.715	0.770
E	6.10	7.49	0.240	0.295
E <sub>1</sub>	7.62	10.03	0.300	0.395
F	2.54		0.100	
L	3.18	4.19	0.125	0.165
Q	0.51	1.02	0.020	0.040
S	1.91	2.29	0.075	0.090

Ceramic Package

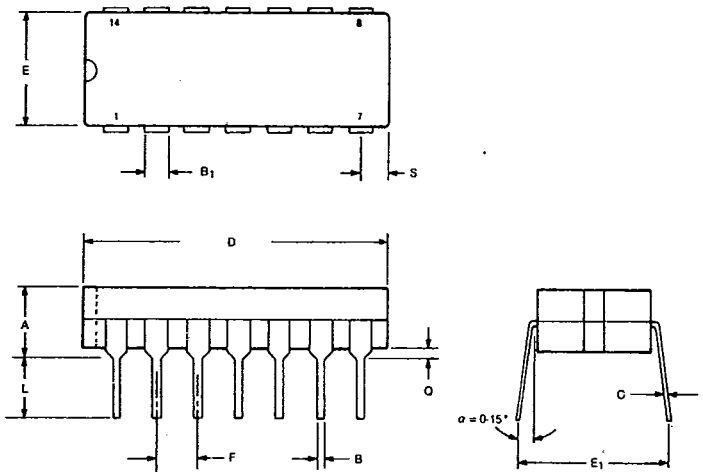

DIM	Millimeters		Inches	
	Min	Max	Min	Max
A	—	5.08	—	0.200
B	0.38	0.58	0.015	0.023
B <sub>1</sub>	1.40	1.78	0.055	0.070
C	0.20	0.38	0.008	0.015
D	19.05	19.94	0.750	0.785
E	6.10	7.49	0.240	0.295
E <sub>1</sub>	7.62	10.03	0.300	0.395
F	2.54		0.100	
L	3.18	4.19	0.125	0.165
Q	0.51	1.02	0.020	0.040
S	1.91	2.29	0.075	0.090

16-Pin Packages

Plastic Package

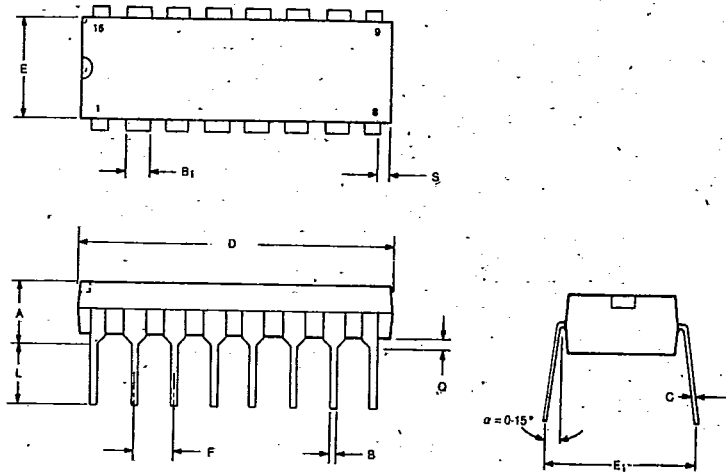

DIM	Millimeters		Inches	
	Min	Max	Min	Max
A	3.81	4.32	0.150	0.170
B	0.38	0.58	0.015	0.023
B <sub>1</sub>	1.40	1.78	0.055	0.070
C	0.20	0.38	0.008	0.015
D	19.05	19.94	0.750	0.785
E	6.10	7.49	0.240	0.295
E <sub>1</sub>	7.62	8.89	0.300	0.350
F	2.54		0.100	
L	3.18	4.19	0.125	0.165
Q	0.51	1.02	0.020	0.040
S	1.91	2.29	0.075	0.090

Ceramic Package

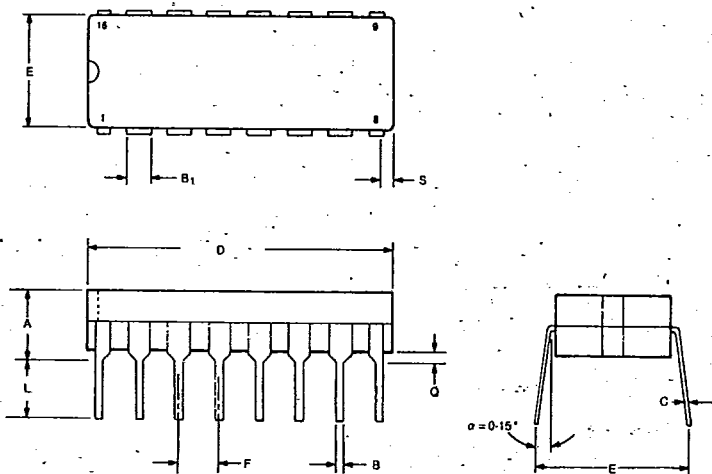

DIM	Millimeters		Inches	
	Min	Max	Min	Max
A	—	5.08	—	0.200
B	0.38	0.58	0.015	0.023
B <sub>1</sub>	1.40	1.78	0.055	0.070
C	0.20	0.38	0.008	0.015
D	19.05	19.94	0.750	0.785
E	6.10	7.49	0.240	0.295
E <sub>1</sub>	7.62	10.03	0.300	0.395
F	2.54		0.100	
L	3.18	4.19	0.125	0.165
Q	0.51	1.02	0.020	0.040
S	1.51	1.14	0.020	0.045

20-Pin Packages

Plastic Package

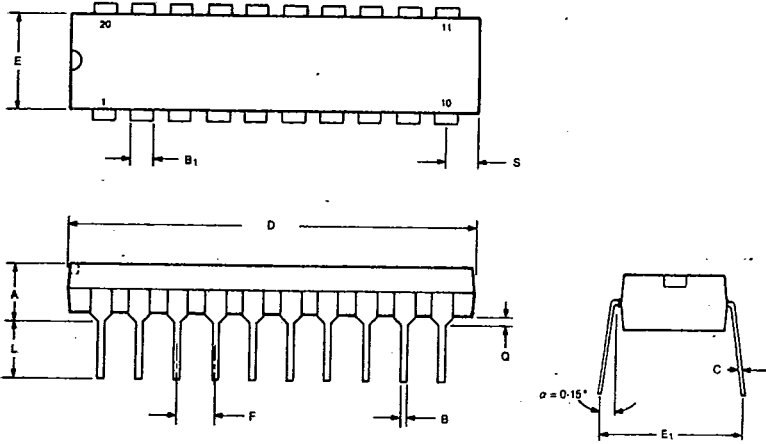

DIM	Millimeters		Inches	
	Min	Max	Min	Max
A	4.06	5.08	0.160	0.200
B	0.38	0.53	0.015	0.021
B <sub>1</sub>	1.14	1.52	0.045	0.060
C	0.20	0.38	0.008	0.015
D	25.65	27.18	1.010	1.070
E	6.10	6.60	0.240	0.260
E <sub>1</sub>	7.77	8.89	0.306	0.350
F	2.54		0.100	
L	3.30	4.01	0.130	0.158
Q	0.38	0.89	0.015	0.035
S	1.85	1.93	0.073	0.076

Ceramic Package

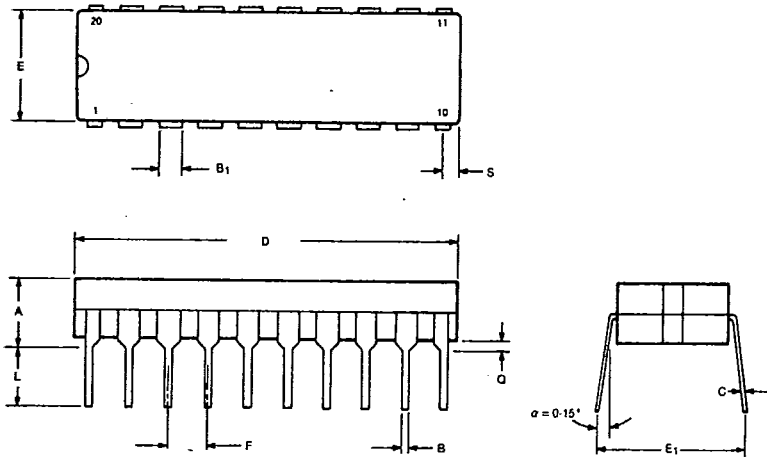

DIM	Millimeters		Inches	
	Min	Max	Min	Max
A	4.06	5.08	0.160	0.200
B	0.38	0.53	0.015	0.021
B <sub>1</sub>	1.14	1.52	0.045	0.060
C	0.20	0.38	0.008	0.015
D	25.78	25.93	1.015	1.021
E	6.10	6.60	0.240	0.260
E <sub>1</sub>	7.77	7.98	0.306	0.314
F	2.54		0.100	
L	3.73	4.01	0.147	0.158
Q	0.38	0.89	0.015	0.035
S	0.51	1.14	0.020	0.045

24-Pin Packages

Plastic Package

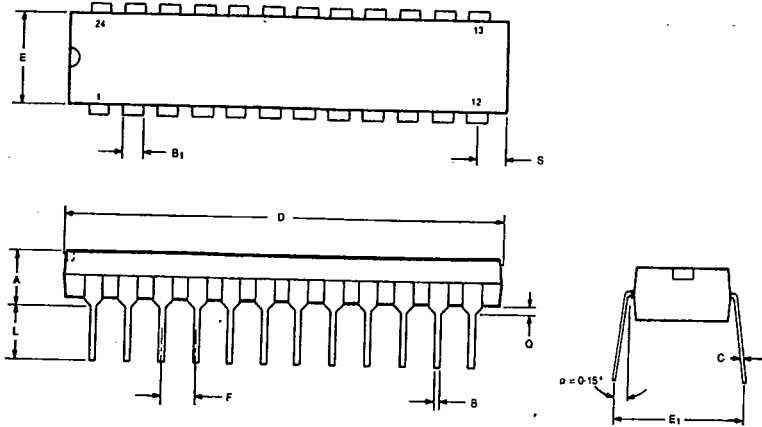

DIM	Millimeters		Inches	
	Min	Max	Min	Max
A	4.06	5.08	0.160	0.200
B	0.38	0.53	0.015	0.021
B <sub>1</sub>	1.14	1.52	0.045	0.060
C	0.20	0.38	0.008	0.015
D	31.24	32.13	1.230	1.265
E	6.10	6.60	0.240	0.260
E <sub>1</sub>	7.77	8.89	0.306	0.350
F	2.54		0.100	
L	3.30	4.01	0.130	0.158
Q	0.38	0.89	0.015	0.035
S	0.51	1.14	0.020	0.045

Ceramic Package

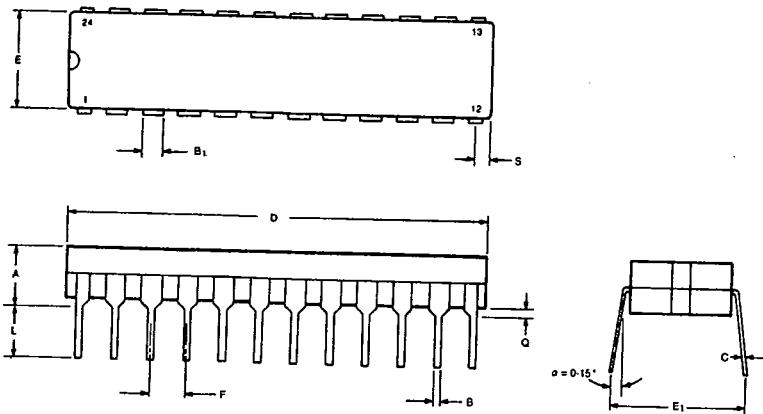

DIM	Millimeters		Inches	
	Min	Max	Min	Max
A	4.06	5.08	0.160	0.200
B	0.38	0.53	0.015	0.021
B <sub>1</sub>	1.14	1.52	0.045	0.060
C	0.20	0.38	0.008	0.015
D	31.50	32.64	1.240	1.285
E	7.24	7.75	0.285	0.305
E <sub>1</sub>	7.77	7.98	0.306	0.314
F	2.54		0.100	
L	3.73	4.01	0.147	0.158
Q	0.508	1.778	0.020	0.070
S	1.85	1.93	0.073	0.076