

T7507 Quad PCM Codec with Filters, Termination Impedance, and Hybrid Balance

Features

- 5 V only
- Low-power, latch-up-free CMOS technology:
 - 37 mW/channel typical operating power dissipation
 - 1 mW/channel typical powerdown dissipation
- Fixed master clock frequency: 2.048 MHz
- On-chip sample and hold, autozero, and precision voltage reference
- Differential architecture for high noise immunity and power supply rejection
- PCM interface:
 - Fixed 2.048 MHz data rate
 - Delayed and nondelayed PCM modes
 - Fully flexible time-slot assignment
 - Transmit and receive aligned or offset
- Transmit PCM data output enable
- Serial control interface with controlling processor
- Latched parallel control interface with SLIC and switch
- Meets or exceeds D3/D4 (as per Agere Systems Inc.'s PUB 43801) and ITU-T G.711—G.714 requirements
- Operating temperature range: -40°C to $+85^{\circ}\text{C}$
- A-law companding
- Hybrid balance and termination impedance:
 - $200\ \Omega$ in series with $680\ \Omega \parallel 0.1\ \mu\text{F}$ (People's Republic of China ZT)
 - Matched with L8567 SLIC
- Programmable receive gain ($-3.5\ \text{dB}$ or $-7\ \text{dB}$), fixed transmit gain ($0\ \text{dB}$) when matched with L8567 SLIC
- 44-pin PLCC

Description

The T7507 device is a single-chip, four-channel A-law PCM codec with filters. This integrated circuit provides analog-to-digital and digital-to-analog conversion. It provides the transmit and receive filtering necessary to interface a voice telephone circuit to a time-division multiplexed system. This device is packaged in a 44-pin PLCC.

This codec is intended for use with Agere's L8567 SLIC. When used with that SLIC, the line tip/ring pair is terminated in the network required for central office applications in the People's Republic of China (PRC). Proper hybrid balance and transmit and receive gains are also obtained.

This device uses a serial data control scheme to interface with the controlling processor. This device has a latched parallel data control scheme to provide control bits to, and receive status bits from, the SLIC and switch. This interface is designed to be compatible with the Agere L8567 SLIC and L7583 solid-state switch.

Table of Contents

Contents	Page	Figures	Page
Features	1	Figure 1. Block Diagram	4
Description.....	1	Figure 2. Pin Diagram.....	5
Pin Information	5	Figure 3. Typical Analog Input Section	8
Functional Description	7	Figure 4. Overload Compression	18
PCM Interface	7	Figure 5. Termination Impedance	21
Analog Interface	8	Figure 6. Transmit and Receive Direction Frequency-Dependent Loss Relative to Gain at 3400 Hz	21
Transmission Levels.....	8	Figure 7. Loss vs. Level	22
Microprocessor Serial Data Control and L8567 SLIC/L7583 Switch (or EMR) Control Interfaces	8	Figure 8. Return Loss	22
Enable Transfers when CCLK Is Bursted with $\overline{\text{CSEL}}$	9	Figure 9. Hybrid Balance	22
Enable Transfers when CCLK Is Not Restricted to $\overline{\text{CSEL}}$ Low.....	9	Figure 10. SLIC/Switch Interface Timing	24
Input Word Definition.....	12	Figure 11. Microprocessor Interface Write Timing	24
Output Word Definition	14	Figure 12. T7507 Transmit and Receive Timing, FSEP = 1 MCLK or IFS = 1, Delayed Timing (D0 = 0)	26
Powerup	14	Figure 13. T7507 Transmit and Receive Timing, FSEP = 1 MCLK or IFS = 1, Nondelayed Timing (D0 = 1)	26
T7507	14	Figure 14. T7507 Receive Timing, FSEP > 1 MCLK and IFS = 0, Delayed Timing (D3 = 0)	27
Output Word.....	14	Figure 15. Typical Frame Sync Timing (IFS = 0)	27
$\overline{\text{EN}}$ Status	14	Figure 16. Basic Loop Start Application Using the T7507 and the L7583 Switch for 200 Ω + (680 Ω 100 nF) Complex Termination and Hybrid Balance	28
Input Word—PCM Interface	14		
Input Word—Relay Control/Timing	14		
Input Word—Control Mode	14		
State Definitions	14		
Powerup	14		
Standby	14		
Full-Chip Powerdown	14		
Absolute Maximum Ratings.....	15		
Handling Precautions	15		
Electrical Characteristics	15		
dc Characteristics.....	15		
Transmission Characteristics	16		
ac Transmission Characteristics	17		
Overload Compression	18		
Chip Set Performance Specifications	21		
Gain.....	21		
Gain Flatness—In Band	21		
Gain Flatness—Out of Band—High Frequencies	21		
Gain Flatness—Out of Band—Low Frequencies	22		
Loss vs. Level Relative to Loss at -10 dBm Input at 1020 Hz	22		
Return Loss	22		
Hybrid Balance	22		
Microprocessor Interface	23		
Timing Characteristics	25		
Applications	28		
Outline Diagram.....	29		
44-Pin PLCC	29		
Ordering Information.....	30		

Table of Contents (continued)

Tables	Page
Table 1. Pin Descriptions	5
Table 2. Microprocessor Interface Descriptions	11
Table 3. C0, C1 Channel Select	12
Table 4. M, D4, D3, D2, D1, D0 Mode Select and Data	12
Table 5. M = 0 Mode (PCM Time-Slot Assignment)	12
Table 6. M = 1, D4 = 0 Mode (Relay State Control and Delayed/Nondelayed Timing)	13
Table 7. M = 1, D4 = 1 Mode (Codec State Control and SLIC State Control)	13
Table 8. Digital Interface	15
Table 9. Power Dissipation	16
Table 10. Analog Interface	16
Table 11. Absolute Gain	17
Table 12. Gain Tracking	17
Table 13. Distortion	17
Table 14. Envelope Delay Distortion	18
Table 15. Decoder Limits Relative to Gain at 1020 Hz	19
Table 16. Encoder Limits, Includes Effect of Termination Impedance Filter Relative to Gain at 1020 Hz	19
Table 17. Termination Impedance Limits Relative to Gain at 1020 Hz	19
Table 18. Hybrid Path Limits Relative to Gain at 1020 Hz	19
Table 19. Noise	20
Table 20. Interchannel Crosstalk (Between Channels)	20
Table 21. Gain	21
Table 22. Gain Flatness—In Band	21
Table 23. Gain Flatness—Out of Band—Low Frequencies	22
Table 24. T7507 Microprocessor Interface Timing	23
Table 25. Clock Section	25
Table 26. T7507 Transmit Section (Delayed Timing).....	25
Table 27. T7507 Transmit Section (Nondelayed Timing).....	25
Table 28. T7507 Receive Section	25

Description (continued)

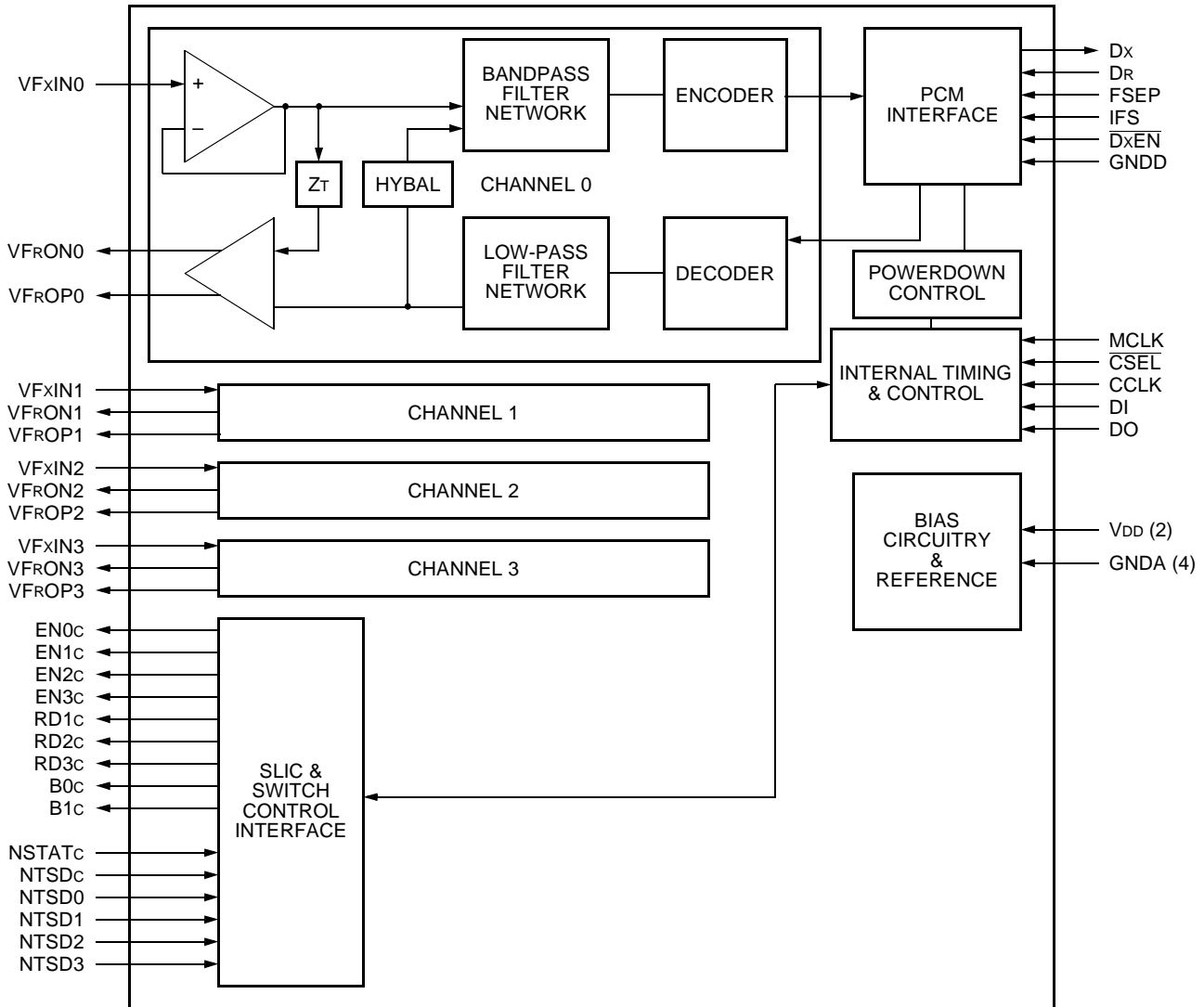

5-3579 (F).a

Figure 1. Block Diagram

Pin Information

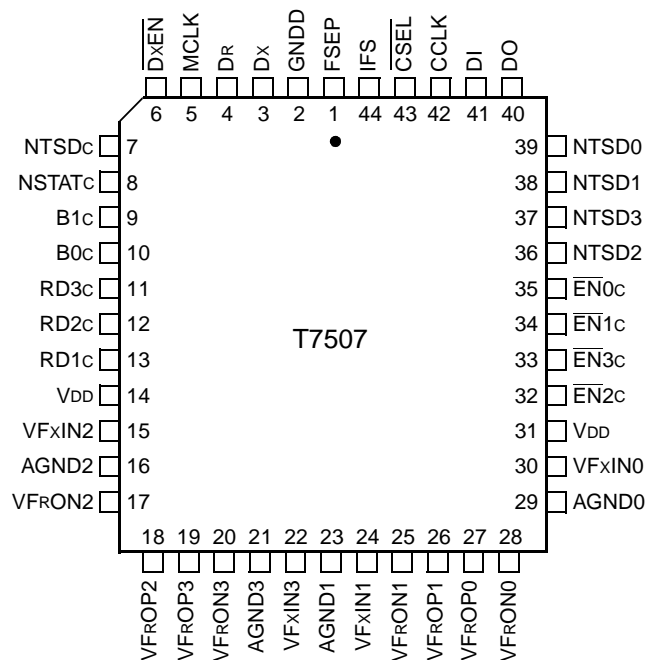

5-5347 (F).a

Figure 2. Pin Diagram

Table 1. Pin Descriptions

Pin	Symbol	Type	Name/Function
1	FSEP	I ^d	Frame Sync Separation. The pulse width of this 8 kHz signal defines the timing offset between the transmit and receive frames. If the IFS pin is 0, internally generated receive frame sync pulses are delayed from the corresponding transmit frame sync pulse rising edge by one less than the FSEP pulse width in negative MCLK edges. If the pulse width is one MCLK period or less or if IFS is high, the transmit and receive frame syncs are made coincident. Loss of FSEP causes the device to power down. A delay of 255 clock pulses is not allowed. Timing relationships between FSEP and time slot 0 are given in Figures 12—14. This input is also the frame sync for all the codec filters and PCM interface timing generated from MCLK. An internal pull-down is on FSEP.
2	GNDD	—	Digital Ground. Ground connection for the digital circuitry. All ground pins must be connected on the circuit board.
3	DX	O	Transmit PCM Data Output. This pin remains in the high-impedance state except during active transmit time slots. An active transmit time slot is defined by programming, FSEP, and the state of IFS. Data is shifted out on the rising edge of MCLK.
4	DR	I	Receive PCM Data Input. The data on this pin is shifted into the device on the falling edges of MCLK. Data is only entered for valid time slots as defined by the relationship of the time-slot programming pulse on the FSEP input, and the state of IFS.
5	MCLK	I	Master Clock Input. The frequency must be 2.048 MHz. This clock serves as the bit clock for all PCM data transfer. A 40% to 60% duty cycle is required.
6	$\overline{\text{DxEN}}$	O	Transmit PCM Data Output Flag. An open-drain output that pulses low during the period when the Dx output is enabled.

Pin Information (continued)

Table 1. Pin Descriptions (continued)

Pin	Symbol	Type	Name/Function
7	NTSDc	I	Not Thermal Shutdown Status Input—L8567 SLIC. Logic level status input from L8567 SLIC indicating if SLIC is in thermal shutdown or normal device operation. This input is accepted from the latched parallel data output of the SLIC and outputted on the serial data output bus DO to the microcontroller. This pin is meant to be a shared output among the four channels associated with the quad T7507, using the \overline{EN} control to determine valid data among the four channels.
8	NSTATc	I	Not Loop Closure/Not Ring Trip Status Input. Logic level status input from L8567 SLIC indicating loop on-/off-hook status. This input is accepted from the latched parallel data output of the SLIC and outputted on the serial data output bus DO to the microcontroller. This pin is meant to be a shared output among the four channels associated with the quad T7507, using the \overline{EN} control to determine valid data among the four channels.
9 10	B1c B0c	O	SLIC State Control. These logic level outputs control the state of the L8567 SLIC. These pins are meant to be a shared output among the four channels associated with the quad T7507, using the \overline{EN} control to determine valid data among the four channels.
11 12 13	RD3c RD2c RD1c	O	Driver Control. These logic level outputs control the state of an electromechanical relay driver on the L8567 SLIC or a solid-state relay contact on the L7583 via the L7583 logic control inputs. These pins are meant to be a shared output among the four channels associated with the quad T7507, using the \overline{EN} control to determine valid data among the four channels.
14 31	VDD	—	5 V Analog Power Supplies. Both pins must be connected on the circuit board. Each pin should be bypassed to ground with at least 0.1 μ F of capacitance as close to the device as possible.
22 15 24 30	VFXIN3 VFXIN2 VFXIN1 VFXIN0	I	Voice Frequency Transmitter Input. Analog inverting input to the noninverting operational amplifier at the transmit filter input. Connect the signal to be digitized to this pin through a capacitor C_i (see Figure 3).
21 16 23 29	AGND3 AGND2 AGND1 AGND0	—	Analog Grounds. All ground pins must be connected on the circuit board.
20 17 25 28	VFRON3 VFRON2 VFRON1 VFRON0	O	Voice Frequency Receiver Negative Output. This pin can drive 2000 Ω (or greater) loads.
19 18 26 27	VFRON3 VFRON2 VFRON1 VFRON0	O	Voice Frequency Receive Positive Output. This pin can drive 2000 Ω (or greater) loads.
39 38 36 37	NTSD0 NTSD1 NTSD2 NTSD3	I	Not Thermal Shutdown Status Input—L7583 Switch. Logic level status input from L7583 solid-state switch indicating if switch is in thermal shutdown or normal device operation. This input is accepted on a per-line basis from the four switches associated with the quad T7507, and outputted on the serial data output bus DO to the microcontroller. If unused, tie to ground or 5 V.

Pin Information (continued)

Table 1. Pin Descriptions (continued)

Pin	Symbol	Type	Name/Function
35 34 32 33	$\overline{EN}0c$ $\overline{EN}1c$ $\overline{EN}2c$ $\overline{EN}3c$	O	Enable. Per-line data enable control for L8567 SLIC and L7583 solid-state switch. Connect to \overline{EN} pin of L8567 SLIC and LATCH input of L7583 switch on a per-line basis. When low, data latch on L8567 and L7583 inputs are transparent and data will flow through the latch. When low, data is valid on L8567 supervision outputs. When high, data input latches on L8567 and L7583 are latched and data on L8567 supervision outputs is not valid. These pulses are generated internally by the T7507 and are generated sequentially when CCLK is present.
40	DO	O	Data Output for Serial Microprocessor Interface.
41	DI	I	Data Input for Serial Microprocessor Interface.
42	CCLK	I	Control Clock for Serial Microprocessor Interface. This is the clock for the micro interface, SLIC, and switch parallel interface. This clock shifts serial information into the DI pin during valid write-read cycles (defined by detection of valid \overline{CSEL}). This clock can be asynchronous to other system clocks. Note: Maximum clock frequency is 2.048 MHz.
43	\overline{CSEL}	I ^u	Chip Select for Serial Microprocessor Interface (Active-Low). Chip select for serial microprocessor interface. An internal pull-up is on \overline{CSEL} .
44	IFS	I ^d	Inhibit Frame Separation. If this bit is set to 0, FSEP functions as defined. If this bit is set to 1, the width of FSEP has no effect on Dx and DR timing relationship. In this case, timing is as if FSEP = 1 MCLK. An internal pull-down is on IFS.

Functional Description

PCM Interface

Four channels of PCM data input and output are passed through two ports, Dx and DR, so some type of time-slot assignment is necessary. The scheme used here is to utilize a timing mode of 32 time slots corresponding to a fixed master clock frequency of 2.048 MHz. Transmit to PCM data is output on pin Dx, and receive from PCM data is input on pin DR. Time-slot assignment is done via the serial control data interface and is fully flexible. Any channel of any codec may be assigned to any of the 32 time slots. See Table 2 for additional details.

Delayed or nondelayed timing is selectable via the serial control data interface. In the nondelayed mode, time slot 0 nominally begins on the rising edge of FSEP. In the delayed mode, time slot 0 nominally starts on the MCLK positive edge following the negative edge that detects FSEP. The start of PCM data can be delayed in 8 MCLK increments by programming the time-slot bits via the microprocessor interface.

There is a single frame sync separation input pin, FSEP. This input provides two functions: it provides a clock for internal timing, and it sets the timing offset (if

any) between the transmit and receive frames for a given channel on the PCM highway. There must always be an 8 kHz signal on FSEP, since this input provides the 8 kHz clock required to maintain internal timing. By adjusting the duty cycle of FSEP, the offset between the transmit and receive frames for a given channel on the PCM highway is set. The number of negative clock edges minus one that occurs while FSEP is high is the delay (in clock periods) that is placed between the rising edge of a transmit frame sign bit and the falling edge used by the receiver to sample the sign bit. If FSEP is high for one clock period or less, the device makes the transmit edges and receive sampling edges one-half clock period apart.

Alternately, the inhibit frame separation (IFS) pin can be used to force the one-half clock period state, regardless of the length of FSEP. If the IFS pin is tied low, FSEP functions as defined above in determining the PCM transmit/receive offset. If IFS is tied high, the width of FSEP has no effect on the Dx/DR timing relationship; timing is as if FSEP = 1 MCLK. Regardless of how IFS is tied, an 8 kHz signal must still be applied to FSEP to maintain internal timing. Tying IFS high simply negates the effect of the duty cycle of FSEP on the Dx/DR timing relationship.

Functional Description (continued)

PCM Interface (continued)

The entire device is placed in a powerdown mode if FSEP remains low for 500 μ s. Powerdown is not guaranteed if MCLK is lost unless the device is already in the powerdown mode due to FSEP low for at least 500 μ s.

The T7507 also offers an output pin, $\overline{\text{DxEN}}$. This pin is an open-drain output that pulses low during the period when the Dx output is enabled.

Analog Interface

The analog input section (Figure 3) includes an on-chip buffer op amp and internal gain. Feedback paths (ZT and HYBAL in Figure 1) are included in the T7507 to generate signals needed for termination impedance and hybrid balance.

When matched with a SLIC with a transconductance from tip/ring of 39.75 V/A and a differential gain to tip/ring of 2 (such as the Agere Systems L8567), and when a solid-state switch (such as the Agere L7583) and 50 Ω of series protection are used, the T7507 will synthesize a complex line termination impedance and hybrid balance network of 200 Ω + 680 Ω || 100 nF. Additionally, the T7507 will fix the line circuit tip/ring to PCM transmit gain at 0 dB (at 1000 Hz, -0.7 dB, +0.3 dB) and will allow a user-selectable (via the serial control input) PCM to tip/ring receive gain of -3.5 dB or -7.0 dB (at 1000 Hz, -0.7 dB, +0.3 dB). Thus, the ac interface between the T7507 and the L8567 SLIC consists of a single dc blocking capacitor in the transmit direction, and a direct connection requiring no external components in the receive direction. The T7507/L8567/L7583 chip set is designed to meet all MPT requirements for the People's Republic of China.

Transmission Levels

Zero transmission-level points are specified relative to the digital milliwatt sequence prescribed by ITU-T recommendation G.711. Under these conditions, an analog input of 0.0452 Vrms applied to VFxIN produces a 0 dBm digital code, while a 0 dBm code input at DR produces an output of 0.394 Vrms differentially at VFRON/VFR0P when using the -7.0 dB gain mode (data bit D4 = 0).

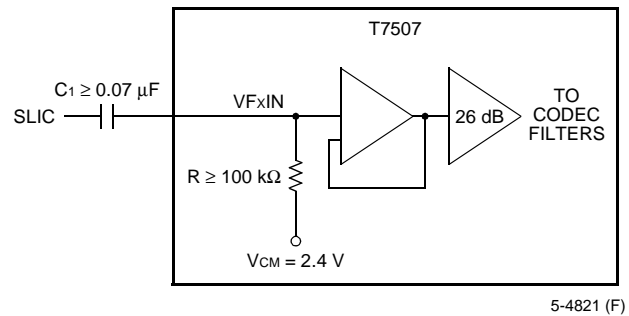

Figure 3. Typical Analog Input Section

Microprocessor Serial Data Control and L8567 SLIC/L7583 Switch (or EMR) Control Interfaces

The basic logic control scheme is a serial data interface between the microcontroller and the T7507. Through this interface, an 8-bit input control word and an 8-bit output status word is passed between the T7507 and microcontroller. The input control word contains information for the T7507, L8567 SLIC, and L7583 switch. The output status word contains off-hook and thermal shutdown status information from the L8567 SLIC and L7583 switch. See the Input Word Definition and Output Word Definition sections of this data sheet for specific details on the input and output words.

Control and status information are passed between the T7507 and L8567 SLIC/L7583 switch via a latched parallel data interface. Data latches are integrated into the L8567 SLIC inputs and outputs and L7583 switch inputs. Thus, a given data I/O on the T7507 serves the corresponding data I/O on the L8567 SLIC for the four channels associated with the quad T7507. Additionally, a given data output on the T7507 serves the corresponding data inputs on the L7583 switch for the four channels associated with the quad T7507. Status information from the L7583 switch is passed to the T7507 on a per-line basis.

The T7507 control interface consists of an 8-bit input serial shift register, an 8-bit output serial shift register, an 8-bit loop status input latch, logic to generate the enable ($\overline{\text{EN}}$) pulses required to control the SLIC and switch data latches, interface logic/buffers between the DI shift register and the internal codec control, and interface logic buffers between the SLIC/switch output control leads.

Functional Description (continued)

Microprocessor Serial Data Control and L8567 SLIC/L7583 Switch (or EMR) Control Interfaces (continued)

The serial data interface has pins for data in (DI), data out (DO), chip select ($\overline{\text{CSEL}}$), and control clock (CCLK). Data is read by the microcontroller from the output shift register at the T7507 DO lead. The T7507 reads data from the microcontroller into the data input shift register at the DI lead. The loop status latch stores updated supervision information from the SLIC and switch until it is transferred to the DO shift register.

On the falling edge of $\overline{\text{CSEL}}$, the first bit of DO output data becomes valid and ready for transmission in the time specified by tCSLCCL. On the next falling CCLK edge, the microprocessor will read the first bit of valid data from the T7507 DO output. Also, on this first falling CCLK edge, the T7507 will read the first bit of control information on the DI input from the microcontroller. Thus, upon the falling $\overline{\text{CSEL}}$ edge, the microcontroller must have valid data ready at its data out lead in a time specified by tCIVCCL.

On the next seven falling CCLK edges, the remaining seven status bits are read by the microcontroller at the T7507 DO lead and the remaining 7 control input bits are read by the T7507 at the DI lead from the microcontroller.

During the time tCCLCSH, which is the period after the eight falling CCLK edges, the data at the DI register is applied to the T7507 codec and made available to the L8567 SLIC and L7583 switch input data latches. Data is applied only if $\overline{\text{CSEL}}$ is low and has remained low on the eighth negative edge of CCLK.

Upon the falling edge of $\overline{\text{CSEL}}$, DO data is passed from the loop status latch to the DO shift register. During the period when $\overline{\text{CSEL}}$ is low, DO status data will not be passed from the loop status latch to the DO shift register. Consecutive read/write periods are not allowed. $\overline{\text{CSEL}}$ must remain high for a specified time, tCSHCSL, before $\overline{\text{CSEL}}$ can transition low again.

During $\overline{\text{CSEL}}$ low interval, the T7507 generates an $\overline{\text{EN}}$ pulse low for one of the four channels served by the particular T7507. These $\overline{\text{EN}}$ pulses are generated sequentially. Thus, if $\overline{\text{EN}}_0$ is generated on a given $\overline{\text{CSEL}}$ low, $\overline{\text{EN}}_1$ will be generated during the next $\overline{\text{CSEL}}$ low, etc. Only one of the four $\overline{\text{EN}}$ outputs associated with a given T7507 codec will be low during a given $\overline{\text{CSEL}}$ interval.

Enable Transfers when CCLK Is Bursted with $\overline{\text{CSEL}}$

When $\overline{\text{EN}}$ is low, status information from the SLIC and switch is updated in the T7507 8-bit loop status latch. This data will be transferred into the data out shift register and shifted out to the microcontroller on the next $\overline{\text{CSEL}}$ cycle. Thus, to make a write from the L8567 SLIC or L7583 switch, it takes two $\overline{\text{CSEL}}$ cycles: the first to create an $\overline{\text{EN}}$ pulse for a given channel and to shift updated status information to the 8-bit status latch, and the second $\overline{\text{CSEL}}$ cycle to shift the updated channel information to the microcontroller. Each time the $\overline{\text{CSEL}}$ goes low and status information is shifted to the microcontroller, only one of the four channels has new status data; the other channels are shifting out status data that has previously been presented to the microcontroller. Thus, it takes five $\overline{\text{CSEL}}$ cycles to a T7507 device to ensure that supervision data for each of the four channels associated with the T7507 device has been updated.

When $\overline{\text{EN}}$ goes low, updated control information is also fed to the SLIC and switch from the T7507. Since $\overline{\text{EN}}$ for each channel is generated sequentially during successive $\overline{\text{CSEL}}$, four $\overline{\text{CSEL}}$ s to a given T7507 device are required to ensure that updated control information is given to each of the four channels.

Note that to apply ringing, before the ring relay is activated to apply power ringing to the subscriber loop, the L8567 SLIC must first be changed from the low-power scan mode to the active mode. This is because the ring trip detector is not active when the L8567 SLIC is in the low-power scan mode. Thus, application of ringing to a given channel may require as many as eight $\overline{\text{CSEL}}$ cycles to the T7507 associated with the channel.

Enable Transfers when CCLK Is Not Restricted to $\overline{\text{CSEL}}$ Low

The T7507 will continue to generate $\overline{\text{EN}}$ pulses sequentially, free-running with CCLK falling edges, when $\overline{\text{CSEL}}$ is not applied low. Thus, if there are long periods of time when $\overline{\text{CSEL}}$ low is not presented to a given T7507 device, enable pulse low will be generated sequentially during this time. This feature allows for the most recent SLIC and switch status information to be maintained in the 8-bit loop status latch during long periods of time when $\overline{\text{CSEL}}$ to a given T7507 device is maintained high.

Functional Description (continued)

Enable Transfers when CCLK Is Not Restricted to $\overline{\text{CSEL}}$ Low (continued)

If $\overline{\text{CSEL}}$ drops low, during the time an $\overline{\text{EN}}$ for a given channel is low, the write cycle to/from the codec will be aborted. However, the $\overline{\text{EN}}$ pulse that will be generated during the eight CCLK cycles that $\overline{\text{CSEL}}$ is low will be for the channel whose $\overline{\text{EN}}$ pulse was aborted by the CSEL dropping low. Thus, for example, if $\overline{\text{EN}}_2$ is low and during the time $\overline{\text{EN}}_2$ is low $\overline{\text{CSEL}}$ is also low, $\overline{\text{EN}}_2$ will immediately go high and any associated write is aborted. Then the $\overline{\text{EN}}$ that is generated because $\overline{\text{CSEL}}$ is low is for channel 2.

The T7507 generates the required enable control signals for the L8567 input data latches, the output data latches, and the L7583 input data latch. A logic low on the L8567 or L7583 latch enable input allows data to flow through the latch. A logic high on the latch enable of the L8567 or L7583 latches the latch. The latch enable is output on a per-line basis from the $\overline{\text{EN}}_0\text{c}$, $\overline{\text{EN}}_1\text{c}$, $\overline{\text{EN}}_2\text{c}$, and $\overline{\text{EN}}_3\text{c}$ outputs of the T7507. The L8567 SLIC and L7583 latches are level sensitive, so when $\overline{\text{EN}}_x$ is low, the data from the SLIC and switch latch flows directly to the T7507 loop status latch. After a high-to-low $\overline{\text{CSEL}}$ transition, on the next falling edge of CCLK, data is transferred from the loop status latch to the serial shift register. Therefore, it is not desirable to update the loop status register on this CCLK edge. For this reason, $\overline{\text{EN}}$ pulses are generated during the rising edge of CCLK.

Note that loop status information from the four channels is accepted on a multiplexed basis at the NSTATc input of the T7507. This information is decoded by the T7507 and placed at the appropriate bit in the 8-bit output word. NSTAT is a wired-OR of the loop closure and ring trip status from the L8567 SLIC.

Thermal shutdown information from the four SLICs is accepted on a multiplexed basis at the NTSDc input of the T7507. Thermal shutdown information from the L7583 switch is accepted on a per-line basis from the four L7583s associated with the quad T7507. The thermal shutdown information from the SLICs is decoded by the T7507 and then ANDed with the thermal shutdown information from the corresponding L7583. This thermal shutdown information for the SLIC and switch is then placed at the appropriate bit in the 8-bit output word.

The control word contains control information for the T7507, L8567 SLIC, and L7583 switch. Thus, the control bits for the L8567 SLIC and L7583 switch need to be transferred via the latched parallel control interface. SLIC control information for the four channels is trans-

ferred on a multiplexed basis through the B0c and B1c output leads on the T7507. L7583 control information (or L8567 relay driver information) is transferred on a multiplexed basis through the RD1c, RD2c, and RD3c output leads.

Three features for the T7507 can be programmed via the serial data interface. The channel receive gain and codec powerup or powerdown are set on a per-channel basis. Delayed and nondelayed timing mode is set globally; all four channels are set to the same mode via the serial data bus. Additionally, PCM time-slot assignment is set via the serial data input bus.

The L8567 B0, B1 state control inputs are latched data inputs. Control data is sent to these inputs via the B0c and B1c outputs of the T7507. The B0c and B1c outputs of the T7507 are meant to control the four SLICs associated with the quad T7507.

Switch control information is sent to the INRING, INTSTIn, or INTSTIn logic control inputs of the L7583 switch, or to the RD1I, RD2I, and RD3I relay driver control inputs of the L8567 SLIC (if EMRS are used) via the RD1c, RD2c, and RD3c T7507 parallel data control outputs. Again, the L7583 state control inputs and the L8567 relay driver control inputs are latched, so control information from the RD1c, RD2c, and RD3c T7507 control outputs are meant to control four lines.

The L8567 SLIC outputs loop status information via the latched NSTAT output. NSTAT is a wired-OR or the outputs of the L8567 SLIC's loop closure detector and ring trip detector. The loop status information is input to the T7507 via the NSTATc input. Since the L8567 SLIC NSTAT bit is latched, the SLIC output from the four channels associated with the T7507 are accepted at NSTATc.

The L8567 SLIC also outputs a thermal shutdown flag via the latched NTSD output. This thermal shutdown information is input to the T7507 via the NTSDc input. Since the L8567 SLIC NSTAT and NTSD bits are latched, the SLIC output from the four channels associated with the T7507 are accepted at NSTATc and NTSD, respectively.

The L7583 also outputs thermal shutdown status via the TSD output. The TSD output on the L7583 is not latched, so the TSD information is input to the T7507 for the four channels associated with the quad T7507 on a per-line basis via the NTSD0, NTSD1, NTSD2, and NTSD3 T7507 inputs.

The multiplexed thermal shutdown information from the four L8567 SLICs and the per-line thermal shutdown information from the four L7583 switches are manipulated by the T7507 into a per-channel thermal shutdown bit and output on the serial data output DO pin.

Functional Description (continued)

Enable Transfers when CCLK Is Not Restricted to $\overline{\text{CSEL}}$ Low (continued)

It is recommended that a polling process be used during idle periods to ensure that a loop closure detection is recognized by the microcontroller. The maximum nominal control clock (CCLK) frequency is 2.048 MHz. Also note that DO is 3-stated based on the state of $\overline{\text{CSEL}}$. This allows multiple DO outputs from multiple T7507s to be tied to a common DO bus.

Table 2. Microprocessor Interface Descriptions

Symbol	Description
CCLK	May be gapped; Maximum frequency is 2.048 MHz. $\overline{\text{EN}}$ pulses are generated on rising CCLK edges.
$\overline{\text{CSEL}}$	A low-going $\overline{\text{CSEL}}$ initiates a write to the T7507 via the DI pin. At the same time, this initiates a read from the T7507 on the DO pin. Data is written and read on the first eight CCLK negative transitions after $\overline{\text{CSEL}}$ goes low. Data is applied to the T7507 operation only if $\overline{\text{CSEL}}$ is low on the eighth negative edge of CCLK. Consecutive writes are not allowed; $\overline{\text{CSEL}}$ must go high for a minimum 50 ns between write cycles. Additionally, data is shifted from the loop status latch to the serial shift register on the first falling CCLK pulse after $\overline{\text{CSEL}}$ goes low.
DI	Pin for serial input data. Input data is an 8-bit word which sends control information from the microcontroller to the T7507, L8567 SLIC, and L7583 switch. T7507 information is codec state information and PCM time-slot assignment. L8567 and L7583 control information is passed to these components via parallel control output pins. See Input Word Definition section for additional details.
DO	Pin for serial data output. Output data is an 8-bit word which sends status information from T7507 parallel status inputs to the microcontroller via the serial data interface. Status information is received from the T7507 via the parallel control inputs from the L8567 SLIC and L7583 switch. See Output Word Definition section for additional details.

Functional Description (continued)

Input Word Definition

The control data input on DI is an 8-bit word of the format:

C1 C0 M D4 D3 D2 D1 D0

Bits C0 and C1 are the channel select bits. Bit M is a mode control bit. Bits D0, D1, D2, and D3 are data bits. Bit D4 can be either a mode control bit or a data bit. If M is set to 0, the data word is set to the PCM time-slot assignment mode and bit D4 is a data bit. If M is set to 1, then D4 is also a mode set bit. If M, D4 = 1, 0, then the data word represents the relay/switch control delayed/nondelayed timing mode. If M, D4 = 1, 1 then the data word represents the codec/SLIC control mode.

Table 3. C0, C1 Channel Select

C1	C0	Channel
0	0	0
0	1	1
1	0	2
1	1	3

Table 4. M, D4, D3, D2, D1, D0 Mode Select and Data

M	D4	D3	D2	D1	D0
0	Time-Slot Assignment	Time-Slot Assignment	Time-Slot Assignment	Time-Slot Assignment	Time-Slot Assignment
1	0	Delayed/Nondelayed PCM Timing Mode or Reserved*	Relay State Control Information 3	Relay State Control Information 2	Relay State Control Information 1
1	1	T7507 Per Channel Powerup/Powerdown	Channel Receive Gain	B1 SLIC Control Bit	B0 SLIC Control Bit

* Delayed/nondelayed PCM timing is a global parameter—all channels are programmed to the most recent value. To program PCM timing, use C0 = C1 = 0. (That is channel 0.) M = 1, D4 = 0. When programming C1, C0 = 01, M = 1, D4 = 0, then D3 must be programmed to 0. When C1, C0 = 10, 11, M = 1, D4 = 0, then D3 is ignored.

Table 5. M = 0 Mode (PCM Time-Slot Assignment)

D4	D3	D2	D1	D0	Function
0	0	0	0	0	Time Slot 0
0	0	0	0	1	Time Slot 1
			.		
			.		
			.		
1	1	1	1	1	Time Slot 31

Note: Do not assign two channels to the same time slot. If two channels are assigned to the same time slot, the result is indeterminate. It is recommended that time-slot assignment should only be done when the channel is powered down. If multiple chips are tied to the same Dx bus, this can result in bus contention. Thus, reassignment of time slots should be done before the channel is powered up. For all codecs, upon powerup, channel 0 will be assigned to time slot 0, channel 1 will be assigned to time slot 1, channel 2 will be assigned to time slot 2, and channel 3 will be assigned to time slot 3.

Functional Description (continued)

Input Word Definition (continued)

Table 6. M = 1, D4 = 0 Mode (Relay State Control and Delayed/Nondelayed Timing)

D3	D2	D1	D0	Function
0	X	X	X	Delayed timing mode (see Figure 12)*. With C0 = C1 = 00, bit D3 set PCM delayed or non-delayed timing. With C0, C1 = 01, 10, 11, bit D3 is ignored.
1	X	X	X	Nondelayed timing mode (see Figure 13)*. With C0 = C1 = 00, bit D3 set PCM delayed or nondelayed timing. With C0, C1 = 01, 10, 11, bit D3 is ignored.
X	0	X	X	T7507 driver output RD3c at logic low. If T7507 driver output RD3c is applied to the L8567 SLIC RD3I input, this will place the relay driver output on the L8567, RD3O, into the relay not active state. If T7507 output RD3c is used to drive the logic inputs of an L7583 solid-state switch, a logic 0 is applied.
X	1	X	X	T7507 driver output RD3c at logic high. If T7507 driver output RD3c is applied to the L8567 SLIC RD3I input, this will place the relay driver output on the L8567, RD3O, into the relay active state. If T7507 output RD3c is used to drive the logic inputs of an L7583 solid-state switch, a logic 1 is applied.
X	X	0	X	T7507 driver output RD2c at logic low. If T7507 driver output RD2c is applied to the L8567 SLIC RD3I input, this will place the relay driver output on the L8567, RD2O, into the relay not active state. If T7507 output RD2c is used to drive the logic inputs of an L7583 solid-state switch, a logic 0 is applied.
X	X	1	X	T7507 driver output RD2c at logic high. If T7507 driver output RD2c is applied to the L8567 SLIC RD3I input, this will place the relay driver output on the L8567, RD2O, into the relay active state. If T7507 output RD2c is used to drive the logic inputs of an L7583 solid-state switch, a logic 1 is applied.
X	X	X	0	T7507 driver output RD1c at logic low. If T7507 driver output RD1c is applied to the L8567 SLIC RD3I input, this will place the relay driver output on the L8567, RD1O, into the relay not active state. If T7507 output RD1c is used to drive the logic inputs of an L7583 solid-state switch, a logic 0 is applied.
X	X	X	1	T7507 driver output RD1c at logic high. If T7507 driver output RD1c is applied to the L8567 SLIC RD3I input, this will place the relay driver output on the L8567, RD1O, into the relay active state. If T7507 output RD1c is used to drive the logic inputs of an L7583 solid-state switch, a logic 1 is applied.

* Delayed or nondelayed timing is a global parameter. All channels will use the most recently programmed value.

Note: Upon powerup, D3 = D2 = D1 = D0 = 0; that is, delayed timing mode and all relay drivers in the not active state, or 0, 0, 0, are applied to L7583 solid-state relay, which is the idle/talk state.

Table 7. M = 1, D4 = 1 Mode (Codec State Control and SLIC State Control)

D3	D2	D1	D0	Function
0	X	X	X	T7507 Channel Standby
1	X	X	X	T7507 Channel Powerup
X	0	X	X	Channel Receive Gain -3.5 dB*
X	1	X	X	Channel Receive Gain -7.0 dB*
X	X	1	1	L8567 SLIC Powerup, Forward Battery
X	X	0	1	L8567 SLIC Powerup, Reverse Battery
X	X	1	0	L8567 SLIC Low-Power Scan
X	X	0	0	L8567 Disconnect

* Receive gain of -3.5 and -7.0 will be achieved in a 200 Ω + 680 Ω || 0.1 μF termination, when using the T7507 with the L8567 SLIC, L7583 switch, and 50 Ω protection resistors.

Functional Description (continued)

Output Word Definition

The status data input on D0 is an 8-bit word of the format:

NSTAT-Ch0, NTSD-Ch0, NSTAT-Ch1, NTSD-Ch1,
NSTAT-Ch2, NTSD-Ch2, NSTAT-Ch3, NTSD-Ch3

Where:

NSTAT-Ch[0:3] is the wired-OR loop supervision status of the off-hook detector and ring trip detector from Channel [0:3].

NTSD-Ch[0:3] is the wire-ORed thermal shutdown status of the L8567 SLIC and L7583 for Channel [0:3].

Powerup

This section defines the state of the T7507 when power is first applied to the device.

T7507

Upon initial application of power, the T7507 is in the full-chip powerdown state and delayed timing mode.

Output Word

With the initial \overline{CSEL} , after application of power, all eight bits of the output word are undefined. With subsequent \overline{CSEL} , all eight bits of the output word will be set to zero. The output word will remain all 0s until application of \overline{EN} pulses to update the output status information. An output word of all 0s implies that all four channels are in thermal shutdown state and are off-hook.

\overline{EN} Status

Upon application of power, all four \overline{EN} channels will be at logic 1 (which means that no control data is transferred to, and no status information is received from, the SLIC or switch). All \overline{EN} will remain at logic 1 until application of an initial FSEP pulse, at which time \overline{EN} is created as defined in the Microprocessor Interface section of this data sheet.

Input Word—PCM Interface

Upon application of power, the PCM time-slot assignment defaults to the following time-slot assignment:

CH0 Time Slot 0
CH1 Time Slot 1
CH2 Time Slot 2
Ch3 Time Slot 3

Input Word—Relay Control/Timing

Upon application of power, all relay driver control inputs are forced to logic 0. If the relay driver outputs are tied to the L8567 relay driver inputs, upon application of an \overline{EN} signal, the relay drivers are forced into the off state. If applied to the L7583 control input, upon application of an \overline{EN} pulse, the L7583B is forced into the idle/talk state.

Input Word—Control Mode

Upon application of power, the receive gain is -3.5 dB and with the B0/B1 control outputs set to 0/0. Note that B0/B1 = 0/0, the L8567 SLIC is set into the disconnect state upon application of \overline{EN} pulse.

State Definitions

Powerup

All circuits are active. All channels are ready for transmission. \overline{EN} pulses are generated free-running with CCLK.

Standby

This mode is programmed on a per-channel basis via the microprocessor control interface. In this mode, individual channels are powered down (not ready for transmission). All reference circuits are always powered up. \overline{EN} pulses are generated free-running with CCLK. Analog outputs are held at a nominal 2.35 V.

Full-Chip Powerdown

This is a global parameter; that is, all channels are globally set into this mode. In this mode, all channels and all reference circuits are powered down. \overline{EN} is forced to logic high. The T7507 is in this state upon application of power. The T7507 enters this state if FSEP is removed for four 8 kHz frames. The T7507 will remain in this state until reapplication of FSEP.

Absolute Maximum Ratings

Stresses in excess of the absolute maximum ratings can cause permanent damage to the device. These are absolute stress ratings only. Functional operation of the device is not implied at these or any other conditions in excess of those given in the operational sections of this data sheet. Exposure to absolute maximum ratings for extended periods can adversely affect device reliability.

Parameter	Symbol	Min	Max	Unit
Storage Temperature Range	T_{stg}	-55	150	°C
Power Supply Voltage	VDD	—	6.5	V
Voltage on Any Pin with Respect to Ground	—	-0.5	$0.5 + V_{DD}$	V
Maximum Power Dissipation (package limit)	PD	—	600	mW

Handling Precautions

Although protection circuitry has been designed into this device, proper precautions should be taken to avoid exposure to electrostatic discharge (ESD) during handling and mounting. Agere employs a human-body model (HBM) and a charged-device model (CDM) for ESD-susceptibility testing and protection design evaluation. ESD voltage thresholds are dependent on the circuit parameters used to define the model. No industry-wide standard has been adopted for CDM. However, a standard HBM (resistance = 1500 Ω , capacitance = 100 pF) is widely used and therefore can be used for comparison purposes. The HBM ESD threshold presented here was obtained by using these circuit parameters:

HBM ESD Threshold Voltage	
Device	Rating
T7507	>2000 V

Electrical Characteristics

Specifications apply for $T_A = -40$ °C to +85 °C, $V_{DD} = 5$ V \pm 5%, MCLK = 2.048 MHz, and GND = 0 V, unless otherwise noted.

dc Characteristics

Table 8. Digital Interface

Parameter	Symbol	Test Conditions	Min	Typ	Max	Unit
Input Low Voltage	V_{IL}	All digital inputs	—	—	0.8	V
Input High Voltage	V_{IH}	All digital inputs	2.0	—	—	V
Input Current	I_I	Any digital input $GND < V_{IN} < V_{DD}$	-10	—	10	μ A
Input Current, Pins with Pull-up (CSEL)	I_I	Any digital input $GND < V_{IN} < V_{DD}$	2	—	150	μ A
Input Current, Pins with Pull-down (FSEP, IFS)	I_I	Any digital input $GND < V_{IN} < V_{DD}$	-2	—	-150	μ A
Output Low Voltage	V_{OL}	\overline{DxEN} , $Dx = 3.2$ mA	—	—	0.4	V
Output High Voltage	V_{OH}	$Dx = -3.2$ mA	2.4	—	—	V
		$Dx = -320$ μ A	3.5	—	—	V
Output Current in High-impedance State	I_{OZ}	\overline{DxEN} , Dx	-30	—	30	μ A
Input Capacitance	C_I	—	—	—	5	pF

Electrical Characteristics (continued)

dc Characteristics (continued)

Table 9. Power Dissipation

Power measurements are made with outputs unloaded.

Parameter	Symbol	Test Conditions	Min	Typ	Max	Unit
Powerdown Current	I _{DDO}	MCLK present; FSEP = 0.4 V	—	0.4	1	mA
Powerup Current*	I _{DD1}	MCLK, FSEP present; all channels powered up	—	33	40	mA
Standby Current	I _{DDS}	MCLK, FSEP present; all channels powered down	—	7	10	mA

* A nominal 6 mA decrease in current per channel put into standby.

Transmission Characteristics

Table 10. Analog Interface

Parameter	Symbol	Test Conditions	Min	Typ	Max	Unit
Input Resistance, V _{FXIN}	R _{VFXI}	1 V < V _{FXI} < 4 V	100	—	300	k Ω
Input Voltage, V _{FXIN}	V _{IX}	Relative to ground	2.25	2.35	2.5	V
Load Resistance, V _{F_{RON}} to V _{F_{ROP}}	R _{L_{V_{FRO}}}	Differential load	2	—	—	k Ω
Load Capacitance, V _{F_{RON}} to V _{F_{ROP}}	C _{L_{V_{FRO}}}	—	—	—	100	pF
Output Resistance, V _{FRO}	R _{O_{V_{FRO}}}	0 dBm ₀ , 1020 Hz PCM code applied to DR	—	2	20	Ω
		Channel under test in powerdown	3000	—	10000	Ω
dc Output Voltage, V _{F_{ROP}} , V _{F_{RON}}	V _{OR}	Alternating ± 0 A-law PCM code applied to DR	2.20	2.35	2.5	V
dc Output Voltage, V _{F_{ROP}} , V _{F_{RON}} Standby	V _{ORPD}	FSEP = active, no load, channel under test in powerdown	2.15	2.35	2.65	V
Differential dc Output V _{F_{ROP}} – V _{F_{RON}}	Δ V _{OR}	Alternating ± 0 A-law PCM code applied to DR	–60	—	60	mV
Output Leakage Current, V _{F_{ROP}} , V _{F_{RON}} Powerdown	I _{O_{V_{FRO}}}	FSEP = 0.4 V	–30	—	30	μ A
Output Voltage Swing, V _{F_{ROP}} – V _{F_{RON}}	V _{SWR}	R _L = 2 k Ω (differential)	2.6	—	—	V _{p-p}

Transmission Characteristics (continued)

ac Transmission Characteristics

Unless otherwise noted, the analog input is a -26 dBm (at 813Ω), 1020 Hz sine wave. The digital input is a PCM bit stream equivalent to that obtained by passing a 0 dBm0, 1020 Hz sine wave through an ideal encoder. The output level is $\sin(x)/x$ -corrected.

Table 11. Absolute Gain

Parameter	Symbol	Test Conditions	Min*	Typ†	Max*	Unit
Encoder Milliwatt Response (transmit gain tolerance)	EmW	Signal input of 0.0452 Vrms (-26 dBm at 813Ω at 1020 Hz)	—	-0.20	—	dBm0
Decoder Milliwatt Response (receive gain tolerance)	DmW	Measured differential relative to 0.902 Vrms, PCM input of 0 dBm0 1020 Hz RL = $10 \text{ k}\Omega$, receive gain in -7.0 dB mode	—	-7.20	—	dBm0
Relative Gain Variation Referenced to DmW	RGR	Decoder gain = -3.5 dB mode	—	3.5	—	dB

* Combination test results are translated into system-level characteristics guaranteed by Table 21, Figure 8, and Figure 9.

† Overall system-level tolerances are $+0.3$ dB to -0.7 dB in both directions. Therefore, nominal analog levels are shifted by -0.2 dB.

Table 12. Gain Tracking

Parameter	Symbol	Test Conditions	Min	Typ	Max	Unit
Transmit Gain Tracking Error Sinusoidal Input A-law	GTX	$+3$ dBm0 to -37 dBm0	-0.25	—	0.25	dB
		-37 dBm0 to -50 dBm0	-0.50	—	0.50	dB
Receive Gain Tracking Error Sinusoidal Input A-law	GTR	$+3$ dBm0 to -37 dBm0	-0.25	—	0.25	dB
		-37 dBm0 to -50 dBm0	-0.50	—	0.50	dB

Table 13. Distortion

Parameter	Symbol	Test Conditions	Min	Typ	Max	Unit
Transmit Signal to Distortion	SDX	$3 \text{ dBm0} \geq \text{VFxl} \geq -30 \text{ dBm0}$	35	—	—	dB
		$-30 \text{ dBm0} \geq \text{VFxl} \geq -40 \text{ dBm0}$	29	—	—	dB
		$-40 \text{ dBm0} \geq \text{VFxl} \geq -45 \text{ dBm0}$	25	—	—	dB
Receive Signal to Distortion	SDR	$3 \text{ dBm0} \geq \text{VFRO} \geq -30 \text{ dBm0}$	35	—	—	dB
		$-30 \text{ dBm0} \geq \text{VFRO} \geq -40 \text{ dBm0}$	29	—	—	dB
		$-40 \text{ dBm0} \geq \text{VFRO} \geq -45 \text{ dBm0}$	25	—	—	dB
Single-frequency Distortion, Transmit	SFDX	200 Hz—3400 Hz, 0 dBm0 input, output any other single frequency ≤ 3400 Hz	—	—	-38	dBm0
Single-frequency Distortion, Receive	SFDR	200 Hz—3400 Hz, 0 dBm0 input, output any other single frequency ≤ 3400 Hz	—	—	-40	dBm0
Intermodulation Distortion	IMD	Transmit or receive, two frequencies in the range (300 Hz—3400 Hz) at -6 dBm0	—	—	-42	dBm0

Transmission Characteristics (continued)

ac Transmission Characteristics (continued)

Table 14. Envelope Delay Distortion

Parameter	Symbol	Test Conditions	Min	Typ	Max	Unit
Tx Delay, Absolute*	DXA	f = 1600 Hz	—	—	165 to 425	µs
Tx Delay, Relative to 1600 Hz	DXR	f = 500 Hz—600 Hz	—	—	220	µs
		f = 600 Hz—800 Hz	—	—	145	µs
		f = 800 Hz—1000 Hz	—	—	75	µs
		f = 1000 Hz—1600 Hz	—	—	40	µs
		f = 1600 Hz—2600 Hz	—	—	75	µs
		f = 2600 Hz—2800 Hz	—	—	105	µs
Rx Delay, Absolute*	DRA	f = 1600 Hz	135	—	135 to 395	µs
Rx Delay, Relative to 1600 Hz	DRR	f = 500 Hz—1000 Hz	-44	—	—	µs
		f = 1000 Hz—1600 Hz	-30	—	—	µs
		f = 1600 Hz—2600 Hz	—	—	90	µs
		f = 2600 Hz—2800 Hz	—	—	125	µs
		f = 2800 Hz—3000 Hz	—	—	175	µs
Round Trip Delay, Absolute*	DRTA	Any time slot/channel to any time slot/channel f = 1600 Hz	—	—	305 to 625	µs

* Varies as a function of time slots chosen.

Overload Compression

Figure 4 shows the region of operation for encoder signal levels above the reference input power (0 dBm0).

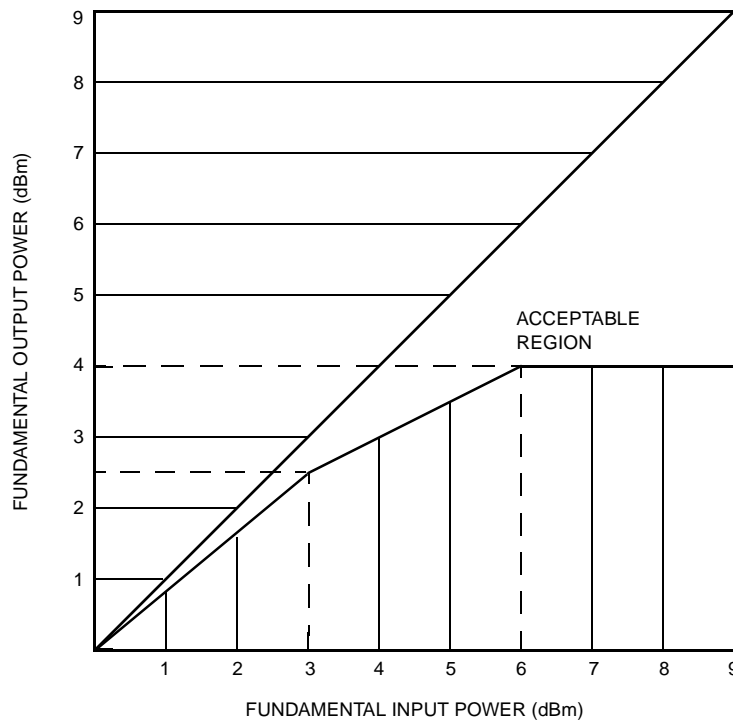

5-3586 (F)

Figure 4. Overload Compression

Transmission Characteristics (continued)

ac Transmission Characteristics (continued)

Table 15. Decoder Limits Relative to Gain at 1020 Hz

Frequency (Hz)	Min	Typ	Max	Unit
15.6	-0.150	—	0.150	dB
46.8	-0.150	—	0.150	dB
62.5	-0.150	—	0.150	dB
453	-0.150	—	0.150	dB
2734	-0.150	—	0.150	dB
3140	-0.550	—	0.150	dB
3375	-0.850	—	0.150	dB
3984	—	—	-13.40	dB
5015	—	—	-28.00	dB

Table 16. Encoder Limits, Includes Effect of Termination Impedance Filter Relative to Gain at 1020 Hz

Frequency (Hz)	Min	Typ	Max	Unit
15.6	—	—	-30.500	dB
46.8	—	—	-25.600	dB
62.5	—	—	-29.400	dB
453	0.400	—	0.700	dB
2734	-2.950	—	-2.650	dB
3140	-3.950	—	-3.250	dB
3375	-4.550	—	-3.850	dB
3984	—	—	-18.30	dB
5015	—	—	-35.00	dB

Table 17. Termination Impedance Limits Relative to Gain at 1020 Hz

Frequency (Hz)	Min	Typ	Max	Unit
46.8	0	—	1	dB
62.5	0.3	—	0.8	dB
453	0.45	—	0.65	dB
2734	-2.95	—	-2.65	dB
3140	-3.60	—	-3.20	dB
3375	-4.05	—	-3.55	dB
3984	-5.05	—	-4.45	dB
5015	-6.35	—	-5.65	dB

Table 18. Hybrid Path Limits Relative to Gain at 1020 Hz

Frequency (Hz)	Min	Typ	Max	Unit
46.8	—	—	-26.000	dB
62.5	—	—	-30.000	dB
453	-0.180	—	0.180	dB
2734	-0.410	—	-0.050	dB
3140	-0.700	—	0.100	dB
3375	-1.640	—	-0.840	dB
3984	—	—	-25.00	dB

Transmission Characteristics (continued)

ac Transmission Characteristics (continued)

Table 19. Noise

Parameter	Symbol	Test Conditions	Min	Typ	Max	Unit
Transmit Noise	NXP	—	—	—	-68	dBm0p
Receive Noise	NRP	PCM code is A-law positive one	—	—	-75	dBm0p
Noise, Single Frequency f = 0 kHz—100 kHz	NRS	VFXIN = 0 Vrms, measurement at VFRO, DR = DX	—	—	-53	dBm0
Power Supply Rejection Transmit	PSRX	VDD = 5.0 Vdc + 100 mVrms: f = 0 kHz—4 kHz f = 4 kHz—50 kHz	36 30	— —	— —	dB dB
Power Supply Rejection Receive	PSRX	PCM code is positive one LSB. VDD = 5.0 Vdc + 100 mVrms: f = 0 kHz—4 kHz f = 4 kHz—25 kHz f = 25 kHz—50 kHz	36 40 30	— — —	— — —	dB dB dB
Spurious Out-of-band Signals at VFRO Relative to Input	SOS	0 dBm0, 300 Hz—3400 Hz input PCM code applied: 4600 Hz—7600 Hz 7600 Hz—8400 Hz 8400 Hz—50 kHz	— — —	— — —	-30 -40 -30	dB dB dB

Table 20. Interchannel Crosstalk (Between Channels)

Parameter	Symbol	Test Conditions	Min	Typ	Max	Unit
Transmit to Receive Crosstalk 0 dBm0 Transmit Levels	CTXX-RY	f = 300 Hz—3400 Hz idle PCM code for channel under test; 0 dBm0 into any other single-channel VFXIN	—	-90	-75	dB
Receive to Transmit Crosstalk 0 dBm0 Receive Levels	CTRX-XY	f = 300 Hz—3400 Hz VFXIN = 0 Vrms for channel under test; 0 dBm0 code level on any other single-channel DR	—	-90	-75	dB
Transmit to Trans- mit Crosstalk 0 dBm0 Transmit Levels	CTXX-XY	f = 300 Hz—3400 Hz 0 dBm0 applied to any single-channel VFXIN except channel under test, which has VFXIN = 0 Vrms	—	-90	-75	dB
Receive to Receive Crosstalk 0 dBm0 Receive Levels	CTRX-RY	f = 300 Hz—3400 Hz 0 dBm0 code level on any single-channel DR except channel under test, which has idle code applied	—	-90	-75	dB

Note: For interchannel, crosstalk into the transmit channels (VFXIN) can be significantly affected by parasitic capacitive feeds from VFRO outputs. PWB layouts should be arranged to keep these parasitics low. The equivalent resistor looking from VFXIN toward VITR (Figure 16) should be kept as low as possible to minimize crosstalk. A maximum of 7 kΩ at 3 kHz is recommended. This is easily achievable in this design with the structure as shown in Figure 16.

Chip Set Performance Specifications

When using the T7507, L8567 SLIC, L7583 solid-state switch, and 50 Ω protection resistors, the following line card requirements are achieved; specified termination impedance is shown in Figure 5.

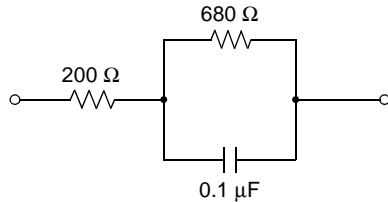

5-5324 (F).a

Figure 5. Termination Impedance

Gain

Table 21. Gain

Gain at 1020 Hz	Min	Typ	Max	Unit
Transmit	-0.7	0	0.3	dB
Receive	-4.2	-3.5	-3.2	dB
Receive	-7.7	-7.0	-6.7	dB

Gain Flatness—In Band

Table 22. Gain Flatness—In Band

The in-band frequency-dependent loss relative to gain at frequency = 1020 Hz, for the transmit and receive directions. This specification is met by using the T7507, L8567 SLIC, L7583 solid-state switch, and 50 Ω protection resistors (200 Ω + 680 Ω || 0.1 μF termination).

Frequency (Hz)	Min	Max	Unit
300—400	-0.3	1.00	dB
400—600	-0.3	0.75	dB
600—2400	-0.3	0.35	dB
2400—3000	-0.3	0.55	dB
3000—3400	-0.3	1.50	dB

Gain Flatness—Out of Band—High Frequencies

The transmit and receive directions' frequency-dependent loss relative to gain at 3400 Hz is shown below. This specification is met by using the T7507, L8567 SLIC, L7583 solid-state switch, and 50 Ω protection resistors (200 Ω + 680 Ω || 0.1 μF termination).

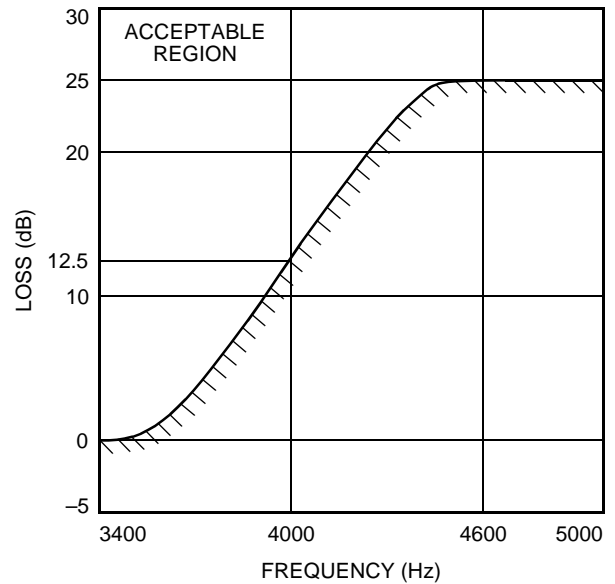

Figure 6. Transmit and Receive Direction Frequency-Dependent Loss Relative to Gain at 3400 Hz

The loss for frequencies 3400 Hz < f < 4600 Hz is given by:

$$b = 12.5 \left[1 - \sin \frac{\pi(4000 - f)}{1200} \right] \text{dB}$$

Chip Set Performance Specifications

(continued)

Gain Flatness—Out of Band—Low Frequencies

Transmit direction only, loss relative to 1020 Hz. This specification is met by using the T7507, L8567 SLIC, L7583 solid-state switch, and 50 Ω protection resistors (200 Ω + 680 Ω || 0.1 μF termination).

Table 23. Gain Flatness—Out of Band—Low Frequencies

Frequency (Hz)	Min Loss (dB)
16.67	30
40	26
50	30
60	30

Loss vs. Level Relative to Loss at -10 dBm Input at 1020 Hz

This specification is met by using the T7507, L8567 SLIC, L7583 solid-state switch, and 50 Ω protection resistors (200 Ω + 680 Ω || 0.1 μF termination).

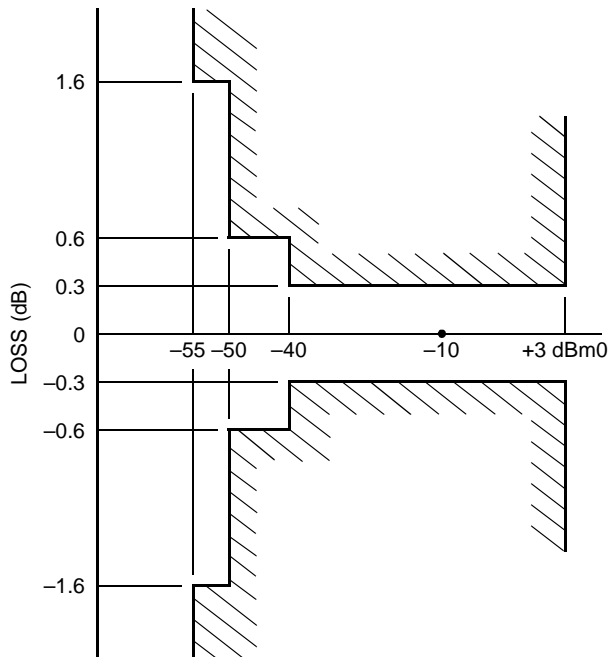

5-5341 (F)

Figure 7. Loss vs. Level

Return Loss

The following template is achieved.

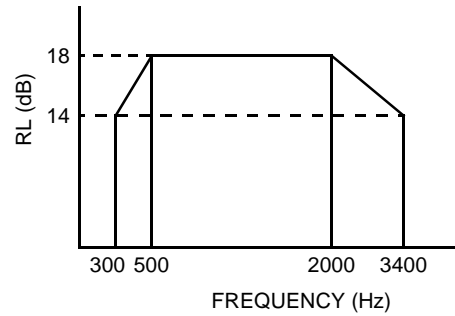

5-5325 (F)

Figure 8. Return Loss

Hybrid Balance

The following template is achieved.

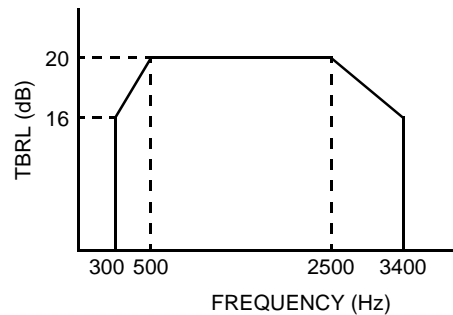

5-5326 (F)

Figure 9. Hybrid Balance

Microprocessor Interface

Table 24. T7507 Microprocessor Interface Timing

Frequency of CCLK = 2.048 MHz.

Symbol	Parameter	Test Conditions	Min	Max	Unit
tCCLCCH	Time of CCLK Low	—	160	—	ns
tCCHCCL	Time of CCLK High	—	160	—	ns
tCCHCCH	Period of CCLK	—	488	—	ns
tCCH1CCH2	Rise Time of CCLK	—	—	50	ns
tCCL1CCL2	Fall Time of CCLK	—	—	50	ns
tCSLCCL	$\overline{\text{CSEL}}$ Low to CCLK Transition	Measured from first CCLK low transition	50	—	ns
tCCLCSH	CCLK Low to $\overline{\text{CSEL}}$ High	Measured from eighth CCLK low transition	30	—	ns
tCIVCCL	Setup Time, Data Input/Output Valid to CCLK Low	—	50	—	ns
tCCLCIX	Hold Time, CCLK Low to Data Input/Output Invalid	—	50	—	ns
tCSHCSL	Minimum Time Between Writes	—	50	—	ns
tSU1BO2	Setup Time for B0—B1 Data	—	488	—	ns
tSU2BO1	Setup Time for B0—B1 Data	—	488	—	ns
tSU1RD	Setup Time for RD1, RD2, RD3 Data	—	488	—	ns
tSU2RD	Setup Time for RD1, RD2, RD3 Data	—	488	—	ns
tENL	Enable Pulse Width	—	977	—	ns

Microprocessor Interface (continued)

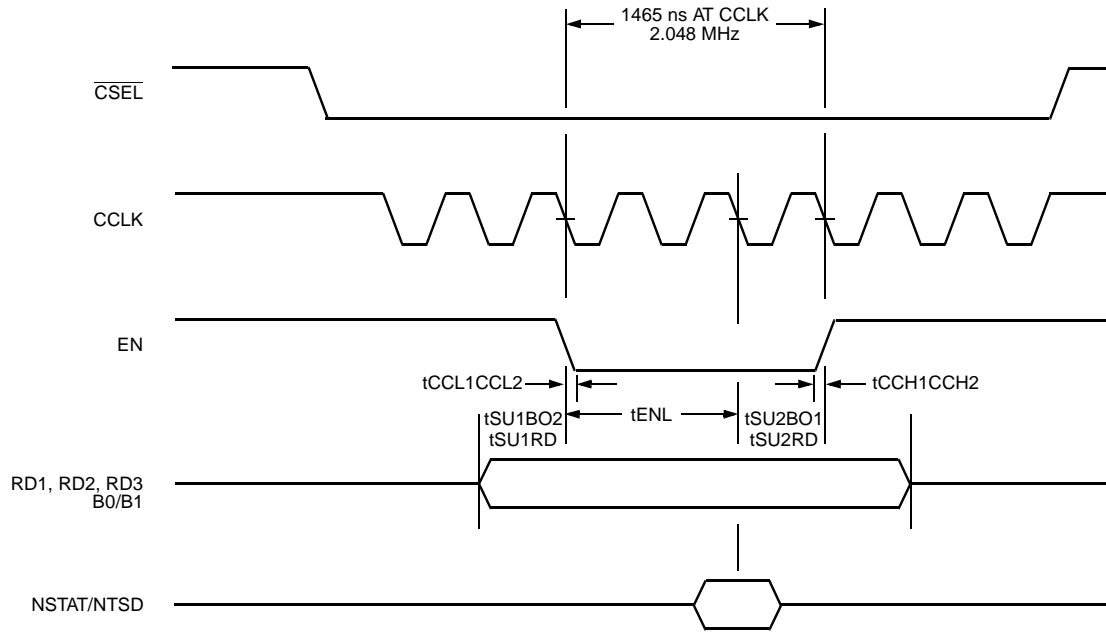

5-5808 (F)

Figure 10. SLIC/Switch Interface Timing

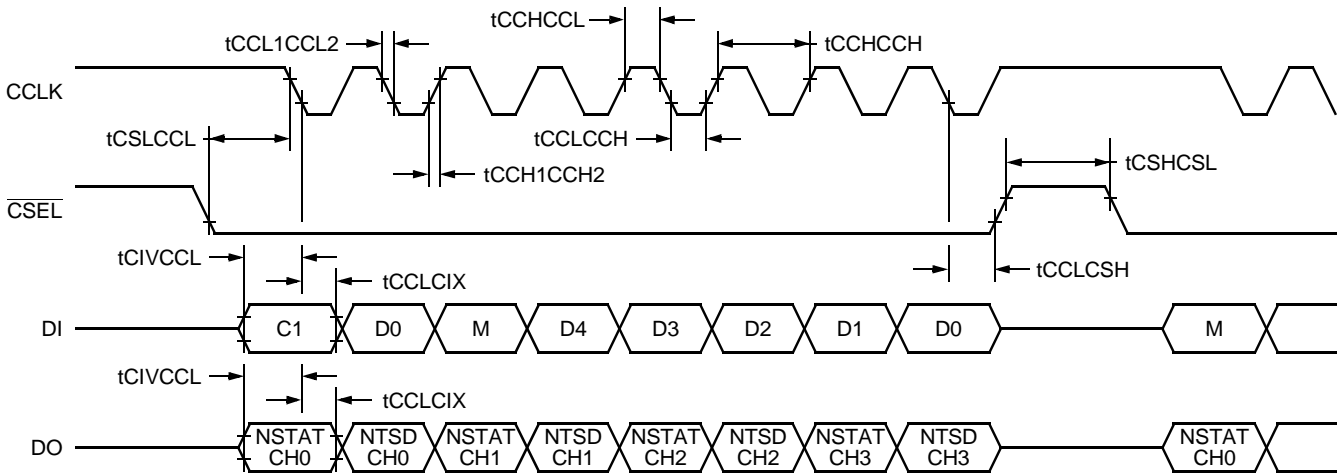

5-4517 (F).b

Figure 11. Microprocessor Interface Write Timing

Timing Characteristics

Table 25. Clock Section

See Figures 12—14.

Symbol	Parameter	Test Conditions	Min	Typ	Max	Unit
tMCHMCL1	Clock Pulse Width	—	97	—	—	ns
tCDC	Duty Cycle, MC	—	40	—	60	%
tMCH1MCH2 tMCL2MCL1	Clock Rise and Fall Time	—	0	—	15	ns

Table 26. T7507 Transmit Section (Delayed Timing)

See Figure 12.

Symbol	Parameter	Test Conditions	Min	Typ	Max	Unit
tMCHDV	Data Enabled on TS Entry	0 < CLOAD < 100 pF	0	—	60	ns
tMCHDV1	Data Delay from MC	0 < CLOAD < 100 pF	0	—	60	ns
tMCLDZ*	Data Float on TS Exit	CLOAD = 0	15	—	100	ns
tSPHMCL	Frame-sync Hold Time	—	50	—	—	ns
tMCLSPH	Frame-sync High Setup	—	50	—	—	ns
tSPLMCL	Frame-sync Low Setup	—	50	—	—	ns
tSPHSPL	Frame-sync Pulse Width	—	0.1	—	125 – tMCHMCH	μs

* Timing parameter tMCLDZ is referenced to a high-impedance state.

Table 27. T7507 Transmit Section (Nondelayed Timing)

See Figure 13.

Symbol	Parameter	Test Conditions	Min	Typ	Max	Unit
tSPHDV	Data Enabled on TS Entry	0 < CLOAD < 100 pF	0	—	80	ns
tMCHDV1	Data Delay from FSx	0 < CLOAD < 100 pF	0	—	60	ns
tMCHDZ*	Data Float on TS Exit	CLOAD = 0	0	—	30	ns
tSPHMCL	Frame-sync Hold Time	—	50	—	—	ns
tMCLSPH	Frame-sync High Setup	—	50	—	—	ns
tSPLMCL	Frame-sync Low Setup	—	50	—	—	ns
tSPHSPL	Frame-sync Pulse Width	—	0.1	—	125 – tMCHMCH	μs

* Timing parameter tMCHDZ is referenced to a high-impedance state.

Table 28. T7507 Receive Section

See Figures 12—14.

Symbol	Parameter	Test Conditions	Min	Typ	Max	Unit
tDVMCL	Receive Data Setup	—	30	—	—	ns
tMCLDV	Receive Data Hold	—	15	—	—	ns
tSPHMCL	Frame Separation Hold Time	—	50	—	—	ns
tSPLMCL	Frame Separation Low Setup	—	50	—	—	ns

Timing Characteristics (continued)

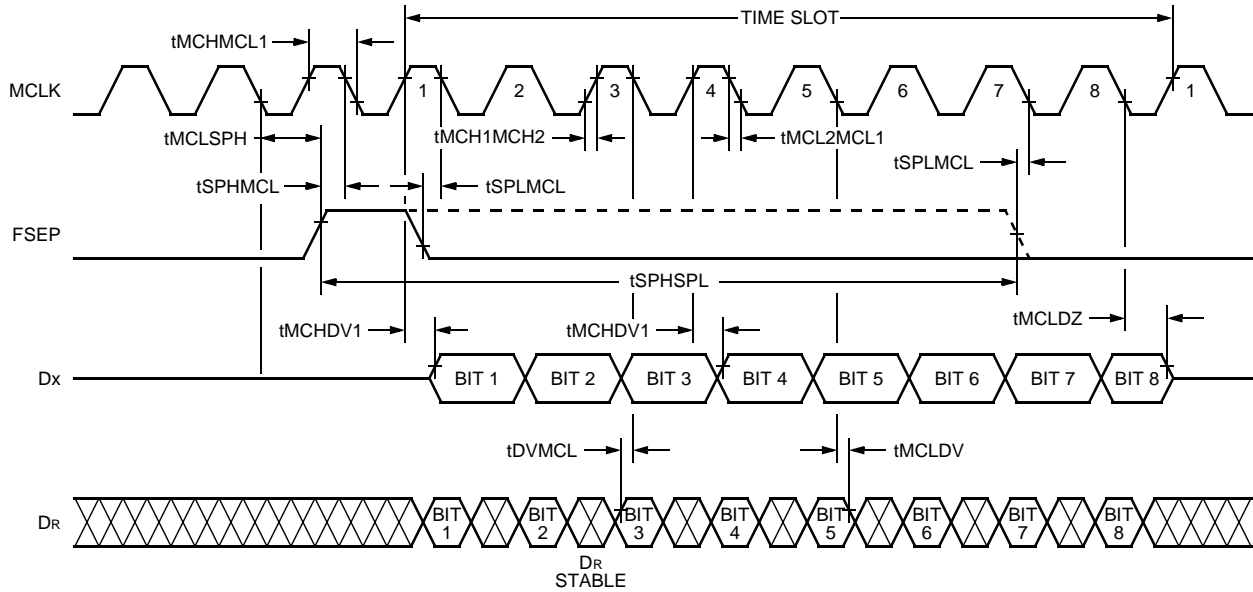

5-3581 (F).g

Figure 12. T7507 Transmit and Receive Timing, FSEP = 1 MCLK or IFS = 1, Delayed Timing (D0 = 0)

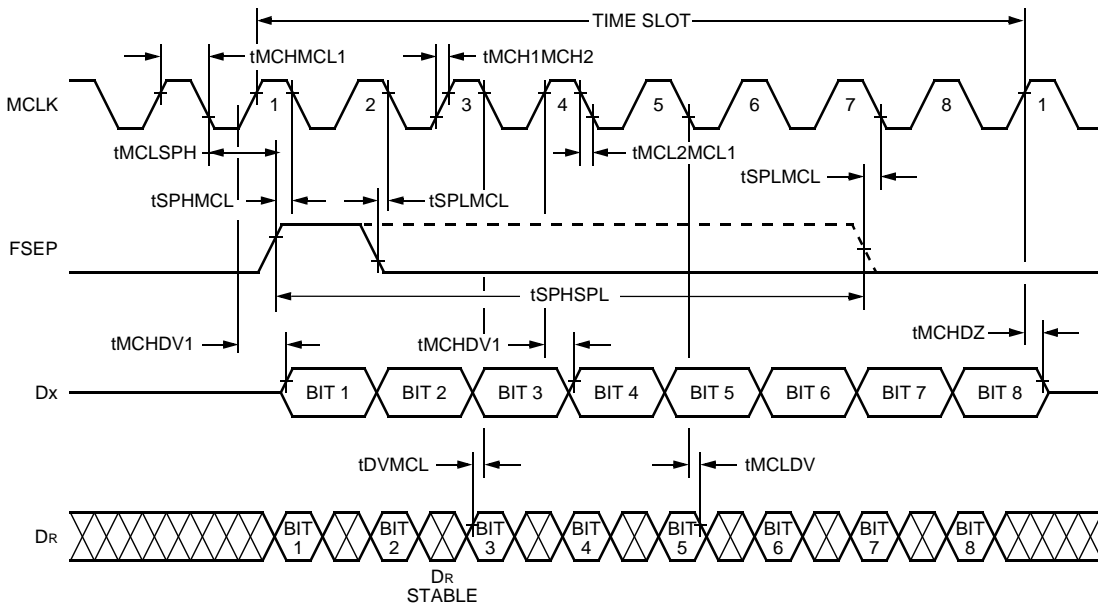

5-3581 (F).h

Figure 13. T7507 Transmit and Receive Timing, FSEP = 1 MCLK or IFS = 1, Nondelayed Timing (D0 = 1)

Timing Characteristics (continued)

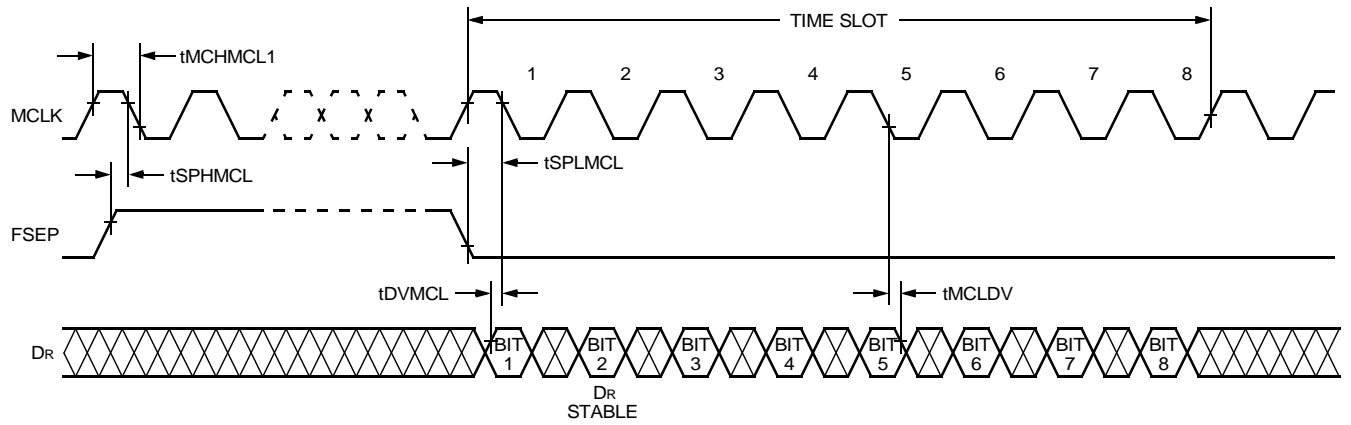

5-3582 (F).b

Figure 14. T7507 Receive Timing, FSEP > 1 MCLK and IFS = 0, Delayed Timing (D3 = 0)

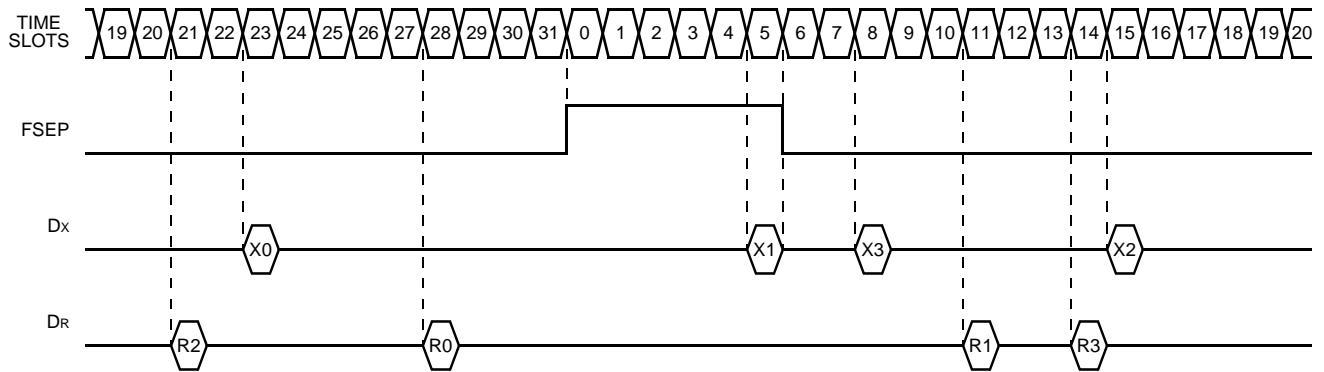

Programming:
00010111 CHANNEL 0 IN TIME SLOT 23
00100101 CHANNEL 1 IN TIME SLOT 5
01001111 CHANNEL 2 IN TIME SLOT 15
01101000 CHANNEL 3 IN TIME SLOT 8

5-4853 (F)

Figure 15. Typical Frame Sync Timing (IFS = 0)

Outline Diagram

44-Pin PLCC

Controlling dimensions are in millimeters.

Note: The dimensions in this outline diagram are intended for informational purposes only. For detailed schematics to assist your design efforts, please contact your Agere Systems Sales Representative.

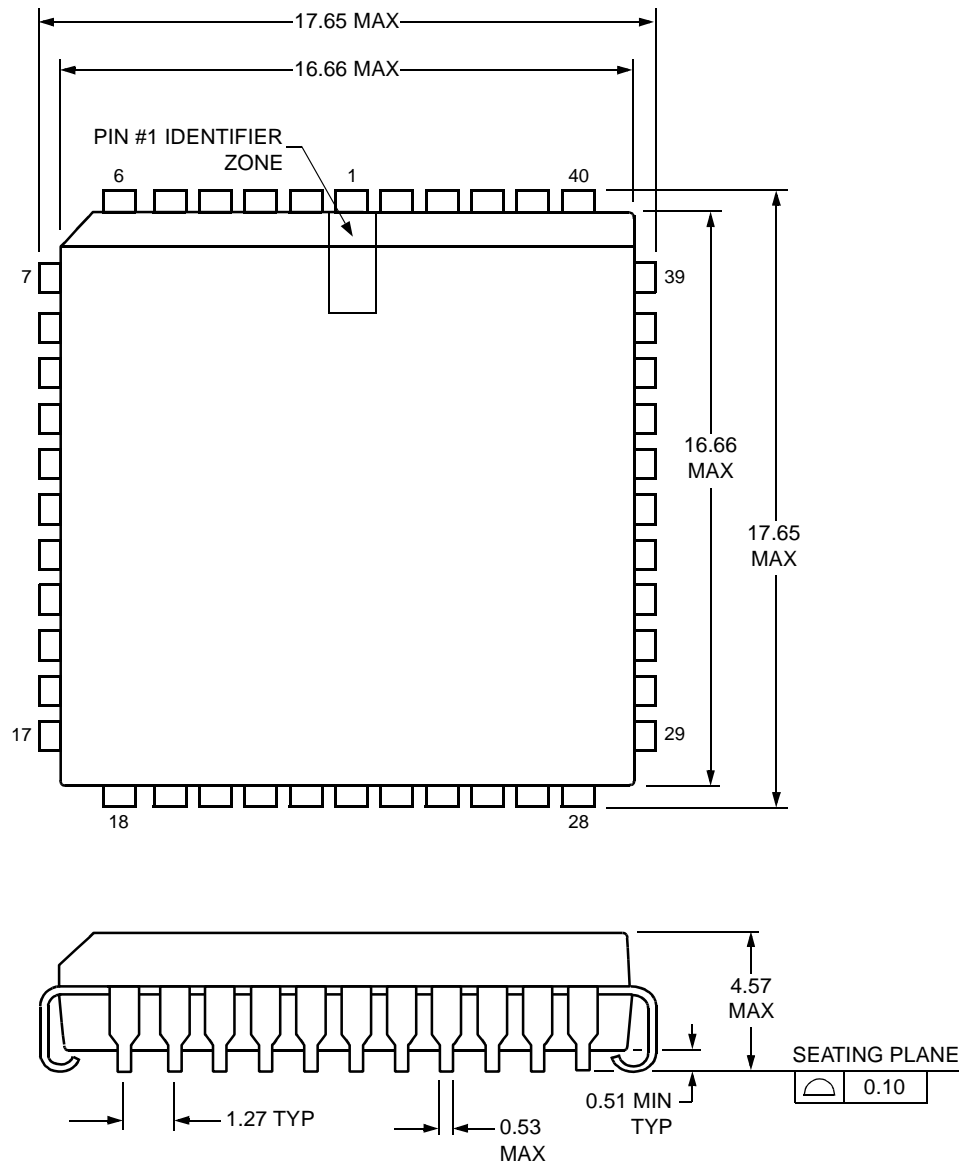

5-2506 (F).r8

Ordering Information

Device Part No.	Description	Package	Comcode
T - 7507 - - - ML2-D	Quad PCM Codec (Dry-bagged)	44-Pin PLCC	108496704
T - 7507 - - - ML2-DT	Quad PCM Codec (Dry-bagged, Tape and Reel)	44-Pin PLCC	108496712

For additional information, contact your Agere Systems Account Manager or the following:

INTERNET: <http://www.agere.com>

E-MAIL: docmaster@agere.com

N. AMERICA: Agere Systems Inc., 555 Union Boulevard, Room 30L-15P-BA, Allentown, PA 18109-3286

1-800-372-2447, FAX 610-712-4106 (In CANADA: 1-800-553-2448, FAX 610-712-4106)

ASIA: Agere Systems Hong Kong Ltd., Suites 3201 & 3210-12, 32/F, Tower 2, The Gateway, Harbour City, Kowloon

Tel. (852) 3129-2000, FAX (852) 3129-2020

CHINA: (86) 21-5047-1212 (Shanghai), (86) 10-6522-5566 (Beijing), (86) 755-695-7224 (Shenzhen)

JAPAN: (81) 3-5421-1600 (Tokyo), KOREA: (82) 2-767-1850 (Seoul), SINGAPORE: (65) 778-8833, TAIWAN: (886) 2-2725-5858 (Taipei)

EUROPE: Tel. (44) 7000 624624, FAX (44) 1344 488 045

Agere Systems Inc. reserves the right to make changes to the product(s) or information contained herein without notice. No liability is assumed as a result of their use or application.