

High Current BCD-to-Seven Segment Decoder/Driver

The MC14547 BCD-to-seven segment decoder/driver is constructed with complementary MOS (CMOS) enhancement mode devices and NPN bipolar output drivers in a single monolithic structure. The circuit provides the functions of an 8421 BCD-to-seven segment decoder with high output drive capability. Blanking (BI), can be used to turn off or pulse modulate the brightness of the display. The MC14547 can drive seven-segment light-emitting diodes (LED), incandescent, fluorescent or gas discharge readouts either directly or indirectly.

Applications include instrument (e.g., counter, DVM, etc.) display driver, computer/calculator display driver, cockpit display driver, and various clock, watch, and timer uses.

- High Current Sourcing Outputs (Up to 65 mA)
- Low Logic Circuit Power Dissipation
- Supply Voltage Range = + 3.0 V to + 18 V
- Blanking Input
- Readout Blanking on All Illegal Combinations
- Lamp Intensity Modulation Capability
- Multiplexing Capability
- Capable of Driving Two Low-Power TTL Loads, One Low-Power Schottky TTL Load or Two HTL Loads over the Rated Temperature Range
- Use MC14511B for Applications Requiring Data Latches

MAXIMUM RATINGS* (Voltages referenced to V_{SS} , Pin 8)

Rating	Symbol	Value	Unit
DC Supply Voltage	V_{DD}	- 0.5 to + 18	V
Input Voltage, All Inputs	V_{in}	- 0.5 to $V_{DD} + 0.5$	V
Operating Temperature Range	T_A	- 55 to + 125	°C
Storage Temperature Range	T_{stg}	- 65 to + 150	°C
Maximum Continuous Output Drive Current (Source) per Output	I_{OHmax}	65	mA
Maximum Continuous Power Dissipation	P_D	1200*	mW

* Maximum Ratings are those values beyond which damage to the device may occur.

* See Power Derating Curve Figure 1.

This device contains circuitry to protect the inputs against damage due to high static voltages or electric fields; however, it is advised that normal precautions be taken to avoid application of any voltage higher than maximum rated voltages to this high-impedance circuit. A destructive high current mode may occur if V_{in} and V_{out} is not constrained to the range $V_{SS} \leq (V_{in} \text{ or } V_{out}) \leq V_{DD}$.

Due to the sourcing capability of this circuit, damage can occur to the device if V_{DD} is applied, and the outputs are shorted to V_{SS} and are at a logical 1 (See Maximum Ratings).

Unused inputs must always be tied to an appropriate logic voltage level (e.g., either V_{SS} or V_{DD}).

MC14547B

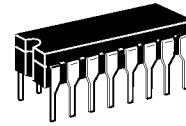

L SUFFIX
CERAMIC
CASE 620

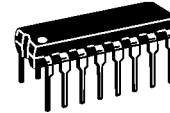

P SUFFIX
PLASTIC
CASE 648



DW SUFFIX
SOIC
CASE 751G

ORDERING INFORMATION

MC14XXXBCP Plastic
MC14XXXBCL Ceramic
MC14XXXBDW SOIC

$T_A = - 55^\circ\text{C}$ to 125°C for all packages.

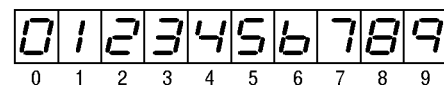
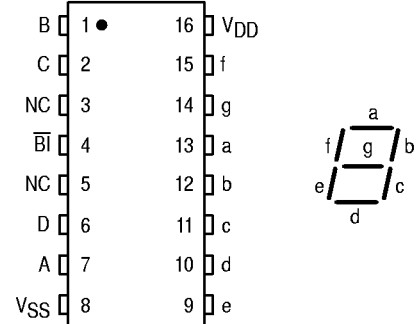

TRUTH TABLE

Inputs				Outputs							Display
\overline{BI}	D	C	B A	a	b	c	d	e	f	g	
0	X	X	X X	0	0	0	0	0	0	0	Blank
1	0	0	0 0	1	1	1	1	1	1	0	0
1	0	0	0 1	0	1	1	0	0	0	0	1
1	0	0	1 0	1	1	0	1	1	0	1	0
1	0	0	1 1	1	1	1	1	0	0	1	1
1	0	1	0 0	0	1	1	0	0	1	1	1
1	0	1	0 1	1	0	1	1	0	1	1	1
1	0	1	1 0	0	0	1	1	1	1	1	1
1	0	1	1 1	1	1	1	0	0	0	0	0
1	1	0	0 0	1	1	1	1	1	1	1	1
1	1	0	0 1	1	1	0	0	0	0	1	1
1	1	0	1 0	0	0	0	0	0	0	0	0
1	1	0	1 1	0	0	0	0	0	0	0	0
1	1	1	0 0	0	0	0	0	0	0	0	0
1	1	1	0 1	0	0	0	0	0	0	0	0
1	1	1	1 0	0	0	0	0	0	0	0	0
1	1	1	1 1	0	0	0	0	0	0	0	0

ELECTRICAL CHARACTERISTICS (Voltages Referenced to V_{SS})

Characteristic	Symbol	V_{DD} Vdc	- 55°C		25°C			125°C		Unit		
			Min	Max	Min	Typ #	Max	Min	Max			
Output Voltage $V_{in} = V_{DD}$ or 0	"0" Level V_{OL}	5.0	—	0.05	—	0	0.05	—	0.05	Vdc		
		10	—	0.05	—	0	0.05	—	0.05			
		15	—	0.05	—	0	0.05	—	0.05			
	"1" Level $V_{in} = 0$ or V_{DD}	V_{OH}	5.0	4.1	—	4.4	4.6	—	4.3		—	Vdc
			10	9.1	—	9.4	9.6	—	9.3		—	
			15	14.1	—	14.4	14.6	—	14.4		—	
Input Voltage # ($V_O = 3.8$ or 0.5 Vdc) ($V_O = 8.8$ or 1.0 Vdc) ($V_O = 13.8$ or 1.5 Vdc)	"0" Level V_{IL}	5.0	—	1.5	—	2.25	1.5	—	1.5	Vdc		
		10	—	3.0	—	4.50	3.0	—	3.0			
		15	—	4.0	—	6.75	4.0	—	4.0			
	V_{IH}	5.0	3.5	—	3.5	2.75	—	3.5	—		Vdc	
		10	7.0	—	7.0	5.50	—	7.0	—			
		15	11	—	11	8.25	—	11	—			
Output Drive Voltage Source ($I_{OH} = 5.0$ mA) ($I_{OH} = 10$ mA) ($I_{OH} = 20$ mA) ($I_{OH} = 40$ mA) ($I_{OH} = 65$ mA)	V_{OH}	5.0	4.0	—	4.2	4.3	—	4.3	—	Vdc		
			—	—	4.1	4.3	—	—	—			
			3.8	—	3.9	4.2	—	4.0	—			
		10	—	—	9.2	9.3	—	9.3	—	9.3	Vdc	
			—	—	9.1	9.3	—	—	—			
			8.8	—	9.0	9.2	—	9.2	—			
		15	—	—	8.9	9.0	—	—	—	—	Vdc	
			—	—	8.9	9.0	—	—	—			
			8.4	—	8.5	8.8	—	8.1	—			
		Output Drive Current Sink ($V_{OL} = 0.4$ Vdc) ($V_{OL} = 0.5$ Vdc) ($V_{OL} = 1.5$ Vdc)	I_{OL}	5.0	0.32	—	0.26	0.44	—	0.18	—	mAdc
				10	0.80	—	0.65	1.13	—	0.45	—	
				15	2.10	—	1.7	4.4	—	1.2	—	
15	—			—	—	—	—	—	—	—		
15	—			—	—	—	—	—	—	—		
15	—			—	—	—	—	—	—	—		
Input Current	I_{in}	15	—	± 0.1	—	± 0.00001	± 0.1	—	± 1.0	μ Adc		
Input Capacitance	C_{in}	—	—	—	—	5.0	7.5	—	—	pF		
Quiescent Current (Per Package) $V_{in} = 0$ or V_{DD} . $I_{out} = 0$ μ A	I_{DD}	5.0	—	5.0	—	0.005	5.0	—	150	μ Adc		
		10	—	10	—	0.010	10	—	300			
		15	—	20	—	0.015	20	—	600			
Total Supply Current**† (Dynamic plus Quiescent, Per Package) ($C_L = 50$ pF on all outputs, all buffers switching)	I_T	5.0	$I_T = (1.9 \mu\text{A}/\text{kHz}) f + I_{DD}$							μ Adc		
		10	$I_T = (3.8 \mu\text{A}/\text{kHz}) f + I_{DD}$									
		15	$I_T = (5.7 \mu\text{A}/\text{kHz}) f + I_{DD}$									

#Noise immunity specified for worst input combination.

Noise Margin for both "1" and "0" level = 1.0 V min @ $V_{DD} = 5.0$ V
 2.0 V min @ $V_{DD} = 10$ V
 2.5 V min @ $V_{DD} = 15$ V

†To calculate total supply current at loads other than 50 pF:

$$I_T(C_L) = I_T(50 \text{ pF}) + 3.5 \times 10^{-3} (C_L - 50) V_{DD} f$$

where: I_T is in μ A (per package), C_L in pF, V_{DD} in V, and f in kHz is input frequency.

**The formulas given are for the typical characteristics only at 25°C.

SWITCHING CHARACTERISTICS ($C_L = 50 \text{ pF}$, $T_A = 25^\circ\text{C}$)

Characteristic	Symbol	V _{DD} Vdc	Min	Typ	Max	Unit
Output Rise Time	t _{TLH}	5.0	—	40	80	ns
		10	—	40	80	
		15	—	40	80	
Output Fall Time	t _{THL}	5.0	—	125	250	ns
		10	—	75	150	
		15	—	70	140	
Data Propagation Delay Time	t _{PLH}	5.0	—	750	1500	ns
		10	—	300	600	
		15	—	200	400	
	t _{PHL}	5.0	—	750	1500	
		10	—	300	600	
		15	—	200	400	
Blank Propagation Delay Time	t _{PLH}	5.0	—	750	1500	ns
		10	—	300	600	
		15	—	200	400	
	t _{PHL}	5.0	—	500	1000	
		10	—	250	500	
		15	—	170	340	

LOGIC DIAGRAM

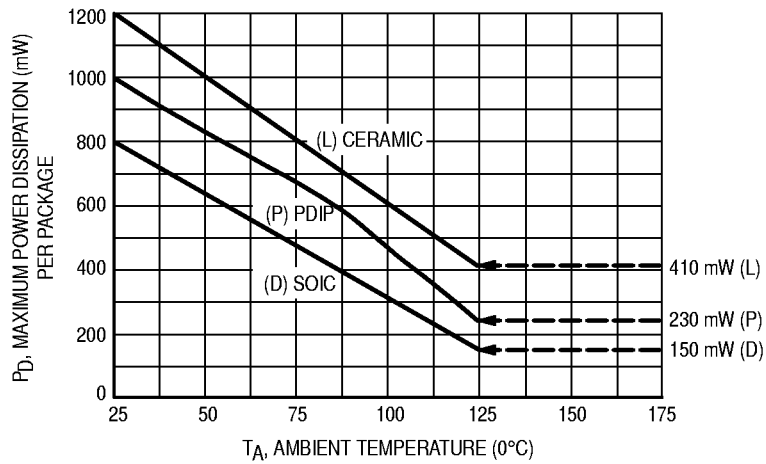
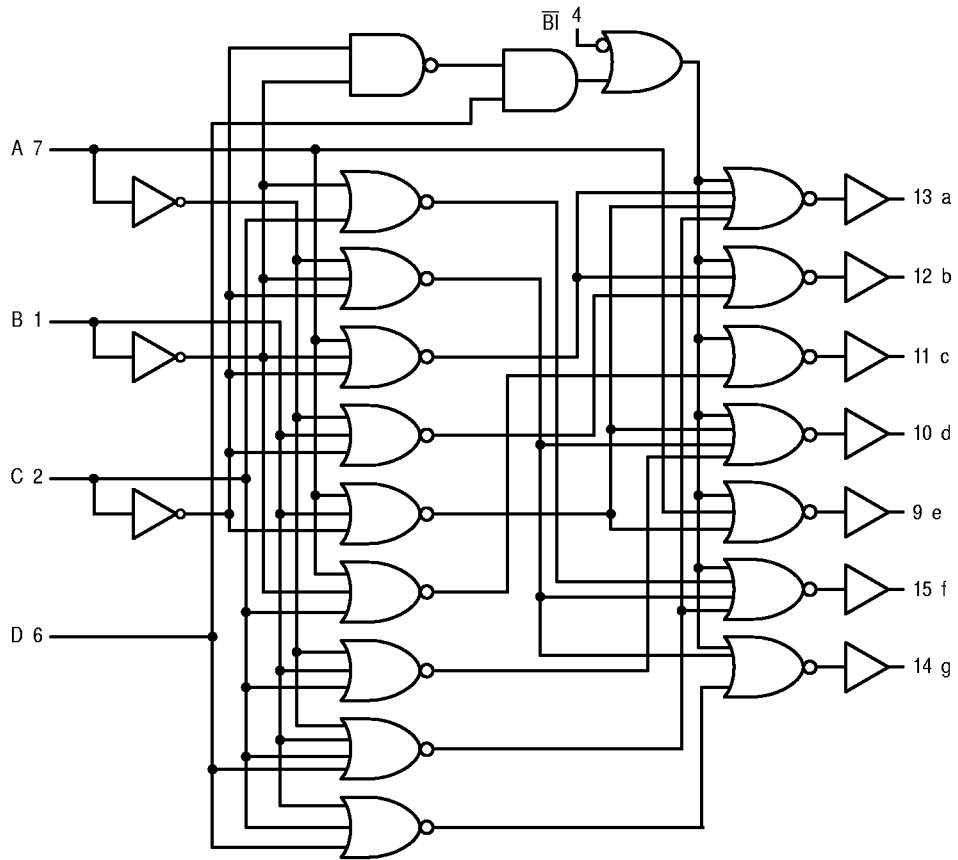
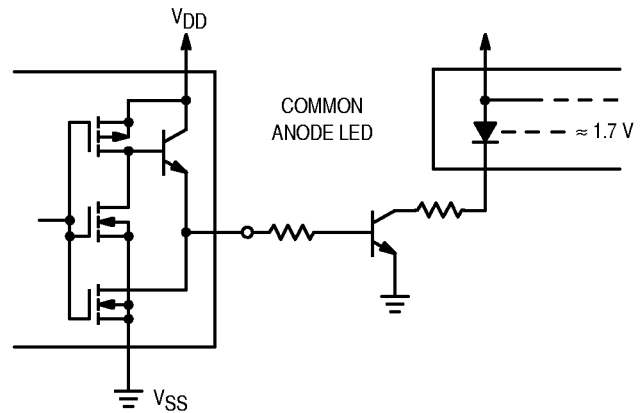
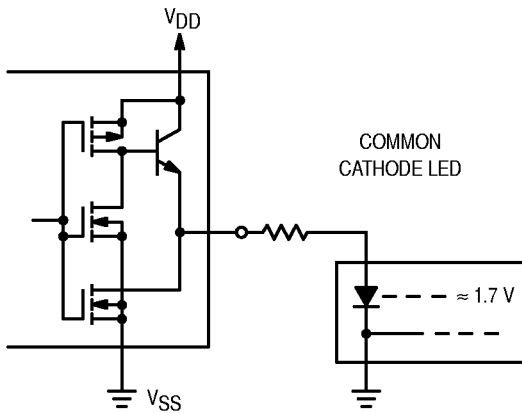

Figure 1. Ambient Temperature Power Derating

CONNECTIONS TO VARIOUS DISPLAY READOUTS

LIGHT EMITTING DIODE (LED) READOUT



INCANDESCENT READOUT

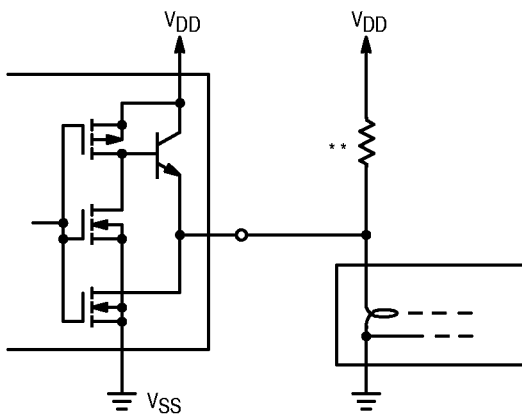

LIGHT-EMITTING DIODE (LED) READOUT USING A ZENER DIODE TO REPLACE DROPPING RESISTORS

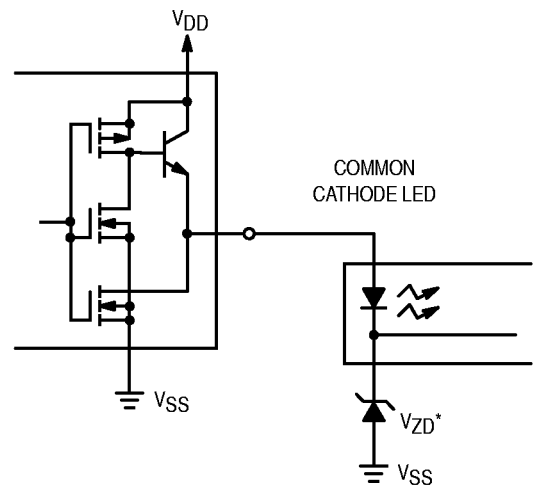

GAS DISCHARGE READOUT

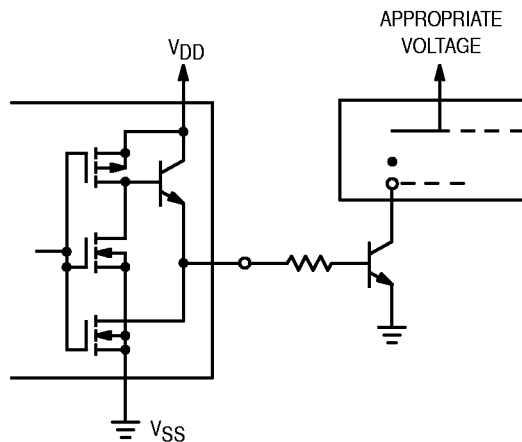

FLUORESCENT READOUT

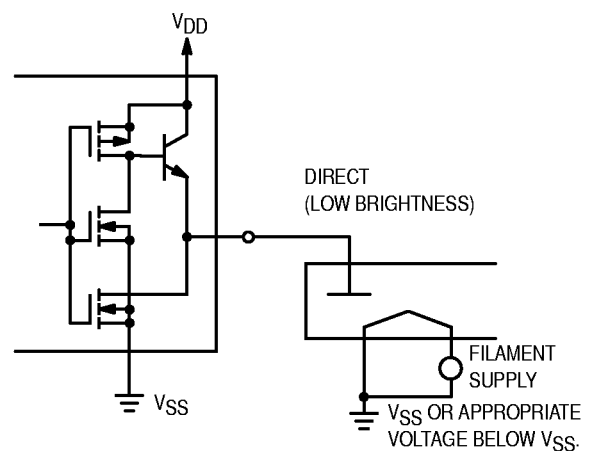

*V_{ZD} should be set at $V_{DD} - 1.3V - V_{LED}$. Wattage of zener diode must be calculated for number of segments and worst-case conditions.

** A filament pre-warm resistor is recommended to reduce filament thermal shock and increase the effective cold resistance of the filament.

(Caution: Absolute maximum working voltage = 18.0 V)

OUTLINE DIMENSIONS

L SUFFIX CERAMIC DIP PACKAGE CASE 620-10 ISSUE V

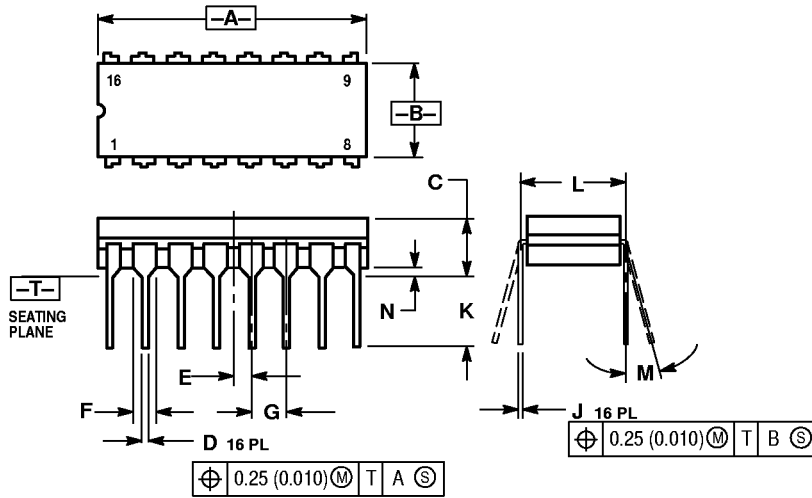

NOTES:

1. DIMENSIONING AND TOLERANCING PER ANSI Y14.5M, 1982.
2. CONTROLLING DIMENSION: INCH.
3. DIMENSION L TO CENTER OF LEAD WHEN FORMED PARALLEL.
4. DIMENSION F MAY NARROW TO 0.76 (0.030) WHERE THE LEAD ENTERS THE CERAMIC BODY.

DIM	INCHES		MILLIMETERS	
	MIN	MAX	MIN	MAX
A	0.750	0.785	19.05	19.93
B	0.240	0.295	6.10	7.49
C	—	0.200	—	5.08
D	0.015	0.020	0.39	0.50
E	0.050 BSC		1.27 BSC	
F	0.055	0.065	1.40	1.65
G	0.100 BSC		2.54 BSC	
H	0.008	0.015	0.21	0.38
K	0.125	0.170	3.18	4.31
L	0.300 BSC		7.62 BSC	
M	0° 15°		0° 15°	
N	0.020	0.040	0.51	1.01

P SUFFIX PLASTIC DIP PACKAGE CASE 648-08 ISSUE R

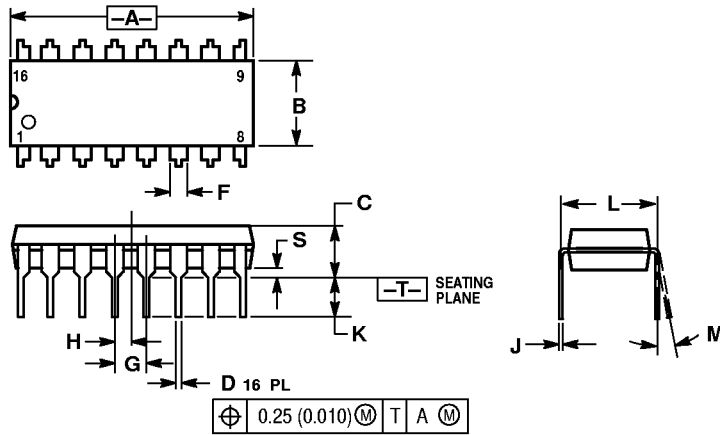

NOTES:

1. DIMENSIONING AND TOLERANCING PER ANSI Y14.5M, 1982.
2. CONTROLLING DIMENSION: INCH.
3. DIMENSION L TO CENTER OF LEADS WHEN FORMED PARALLEL.
4. DIMENSION B DOES NOT INCLUDE MOLD FLASH.
5. ROUNDED CORNERS OPTIONAL.

DIM	INCHES		MILLIMETERS	
	MIN	MAX	MIN	MAX
A	0.740	0.770	18.80	19.55
B	0.250	0.270	6.35	6.85
C	0.145	0.175	3.69	4.44
D	0.015	0.021	0.39	0.53
F	0.040	0.70	1.02	1.77
G	0.100 BSC		2.54 BSC	
H	0.050 BSC		1.27 BSC	
J	0.008	0.015	0.21	0.38
K	0.110	0.130	2.80	3.30
L	0.295	0.305	7.50	7.74
M	0° 10°		0° 10°	
S	0.020	0.040	0.51	1.01

OUTLINE DIMENSIONS

D SUFFIX PLASTIC SOIC PACKAGE CASE 751B-05 ISSUE J

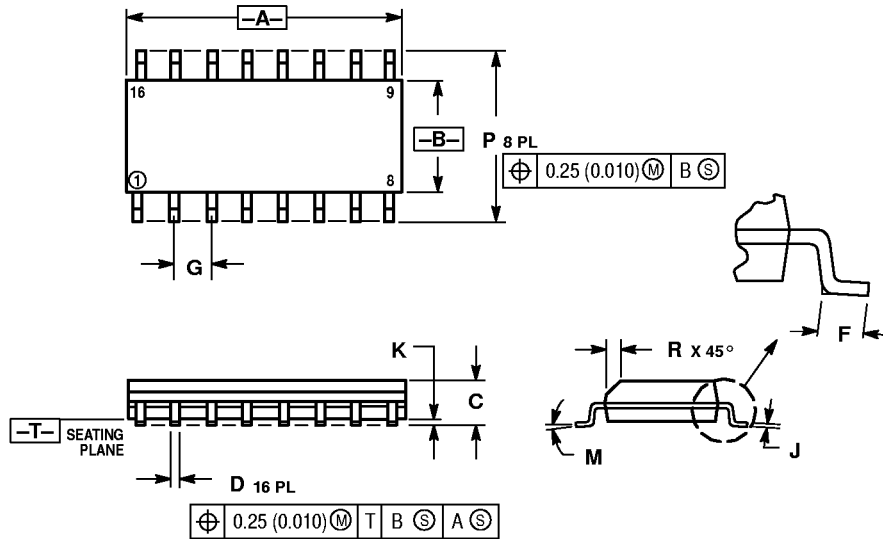

NOTES:

1. DIMENSIONING AND TOLERANCING PER ANSI Y14.5M, 1982.
2. CONTROLLING DIMENSION: MILLIMETER.
3. DIMENSIONS A AND B DO NOT INCLUDE MOLD PROTRUSION.
4. MAXIMUM MOLD PROTRUSION 0.15 (0.006) PER SIDE.
5. DIMENSION D DOES NOT INCLUDE DAMBAR PROTRUSION. ALLOWABLE DAMBAR PROTRUSION SHALL BE 0.127 (0.005) TOTAL IN EXCESS OF THE D DIMENSION AT MAXIMUM MATERIAL CONDITION.

DIM	MILLIMETERS		INCHES	
	MIN	MAX	MIN	MAX
A	9.80	10.00	0.386	0.393
B	3.80	4.00	0.150	0.157
C	1.35	1.75	0.054	0.068
D	0.35	0.49	0.014	0.019
F	0.40	1.25	0.016	0.049
G	1.27 BSC		0.050 BSC	
J	0.19	0.25	0.008	0.009
K	0.10	0.25	0.004	0.009
M	0°	7°	0°	7°
P	5.80	6.20	0.229	0.244
R	0.25	0.50	0.010	0.019

Motorola reserves the right to make changes without further notice to any products herein. Motorola makes no warranty, representation or guarantee regarding the suitability of its products for any particular purpose, nor does Motorola assume any liability arising out of the application or use of any product or circuit, and specifically disclaims any and all liability, including without limitation consequential or incidental damages. "Typical" parameters which may be provided in Motorola data sheets and/or specifications can and do vary in different applications and actual performance may vary over time. All operating parameters, including "Typicals" must be validated for each customer application by customer's technical experts. Motorola does not convey any license under its patent rights nor the rights of others. Motorola products are not designed, intended, or authorized for use as components in systems intended for surgical implant into the body, or other applications intended to support or sustain life, or for any other application in which the failure of the Motorola product could create a situation where personal injury or death may occur. Should Buyer purchase or use Motorola products for any such unintended or unauthorized application, Buyer shall indemnify and hold Motorola and its officers, employees, subsidiaries, affiliates, and distributors harmless against all claims, costs, damages, and expenses, and reasonable attorney fees arising out of, directly or indirectly, any claim of personal injury or death associated with such unintended or unauthorized use, even if such claim alleges that Motorola was negligent regarding the design or manufacture of the part. Motorola and are registered trademarks of Motorola, Inc. Motorola, Inc. is an Equal Opportunity/Affirmative Action Employer.

How to reach us:

USA/EUROPE/Locations Not Listed: Motorola Literature Distribution; P.O. Box 20912; Phoenix, Arizona 85036. 1-800-441-2447 or 602-303-5454

JAPAN: Nippon Motorola Ltd.; Tatsumi-SPD-JLDC, 6F Seibu-Butsuryu-Center, 3-14-2 Tatsumi Koto-Ku, Tokyo 135, Japan. 03-81-3521-8315

MFAX: RMFAX0@email.sps.mot.com – TOUCHTONE 602-244-6609
INTERNET: http://Design-NET.com

ASIA/PACIFIC: Motorola Semiconductors H.K. Ltd.; 8B Tai Ping Industrial Park, 51 Ting Kok Road, Tai Po, N.T., Hong Kong. 852-26629298



MC14547B/D

