

High Power 2 × 4 Antenna Switch MMIC with Integrated Control Logic

Description

The CXG1090TN is a high power antenna switch MMIC. The CXG1090TN is suited to connect Tx/Rx to one of 4 antennas in cellular handset such as PDC.

The CXG1090TN has the integrated control logic and can be operated with CMOS input.

This IC is designed using the Sony's GaAs J-FET process which enable the CXG1090TN to be operated with low voltage.

16 pin TSSOP (Plastic)

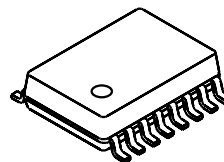

Features

- Low insertion loss: 0.30dB (Typ.)@900MHz, 0.40dB (Typ.)@1.5GHz
- Small package: TSSOP-16pin
- High power handling: PldB: 37dBm
- CMOS compatible input control
- Low bias voltage: $V_{DD} = 3.0V$

Applications

2 × 4 antenna switch for digital cellular telephones such as PDC handsets.

Structure

GaAs J-FET MMIC

Absolute Maximum Ratings

- | | | | |
|-------------------------|-----------|-------------|------------------------|
| • Bias voltage | V_{DD} | 7 | V @ $T_a = 25^\circ C$ |
| • Control voltage | V_{ctl} | 5 | V @ $T_a = 25^\circ C$ |
| • Operating temperature | T_{opr} | -35 to +85 | $^\circ C$ |
| • Storage temperature | T_{stg} | -65 to +150 | $^\circ C$ |

GaAs MMICs are ESD sensitive devices. Special handling precautions are required.

Sony reserves the right to change products and specifications without prior notice. This information does not convey any license by any implication or otherwise under any patents or other right. Application circuits shown, if any, are typical examples illustrating the operation of the devices. Sony cannot assume responsibility for any problems arising out of the use of these circuits.

Block Diagram

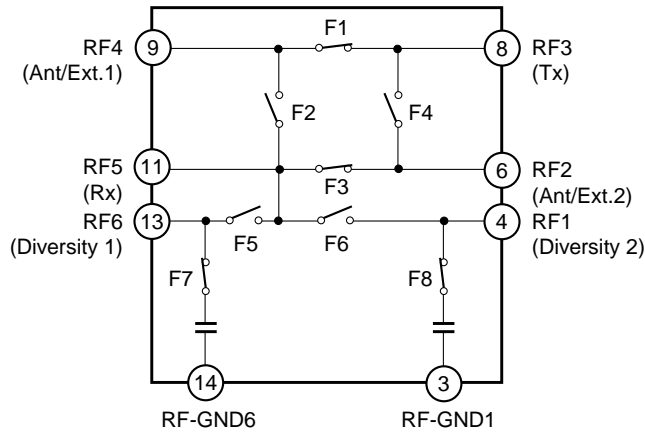

Package Outline/Pin Configuration

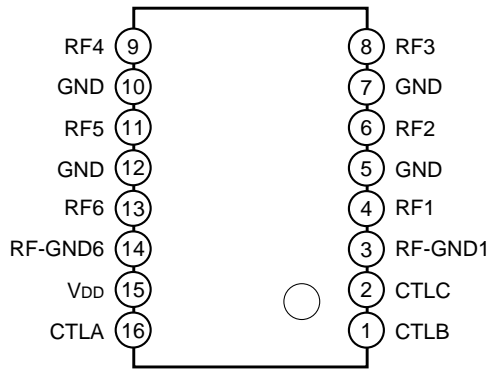

Recommended Circuit

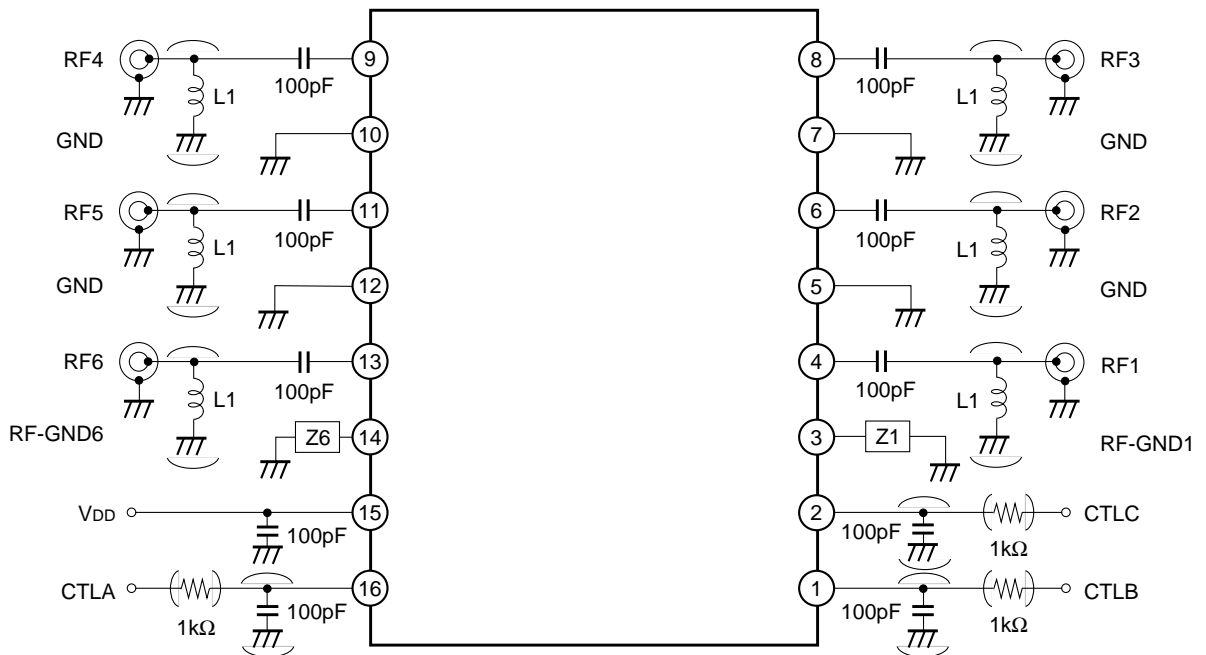

Truth Table

Control			ON	F1	F2	F3	F4	F5	F6	F7	F8
CTLA	CTLB	CTLC									
H	L	L	RF3 → RF2	OFF	ON	OFF	ON	OFF	OFF	ON	ON
H	L	H	RF3 → RF4	ON	OFF	ON	OFF	OFF	OFF	ON	ON
L	L	L	RF5 → RF2	ON	OFF	ON	OFF	OFF	OFF	ON	ON
L	L	H	RF5 → RF4	OFF	ON	OFF	ON	OFF	OFF	ON	ON
L	H	L	RF5 → RF6	OFF	OFF	OFF	OFF	ON	OFF	OFF	ON
L	H	H	RF5 → RF1	OFF	OFF	OFF	OFF	OFF	ON	ON	OFF

DC Bias Condition

(Ta = 25°C)

Parameter	Min.	Typ.	Max.	Unit
Vctl (H) A to C	2.4		3.6	V
Vctl (L) A to C	0		0.8	V
VDD	2.8		3.2	V

Electrical Characteristics

(Vctl (L) = 0V, Vctl (H) = 3V, Ta = 25°C)

Parameter		Frequency	Condition	Min.	Typ.	Max.	Unit
Insertion loss	RF3-RF2	889 to 960MHz	Pin = 29.5dBm, V _{DD} = 2.8 to 3.0V		0.32	0.55	dB
	RF3-RF4	889 to 960MHz	Pin = 29.5dBm, V _{DD} = 2.8 to 3.0V		0.30	0.55	dB
	RF5-RF2	810 to 885MHz	Pin = 7dBm, V _{DD} = 2.8 to 3.0V		0.55	0.85	dB
	RF5-RF4	810 to 885MHz	Pin = 7dBm, V _{DD} = 2.8 to 3.0V		0.55	0.85	dB
	RF5-RF1	810 to 885MHz	Pin = 7dBm, V _{DD} = 2.8 to 3.0V		0.5	0.8	dB
	RF5-RF6	810 to 885MHz	Pin = 7dBm, V _{DD} = 2.8 to 3.0V		0.5	0.8	dB
Isolation	RF3-RF2	889 to 960MHz	Pin = 29.5dBm, V _{DD} = 2.8 to 3.0V	17	19		dB
	RF3-RF4	889 to 960MHz	Pin = 29.5dBm, V _{DD} = 2.8 to 3.0V	17	21		dB
	RF5-RF2	810 to 885MHz	Pin = 7dBm, V _{DD} = 2.8 to 3.0V	17	21		dB
	RF5-RF4	810 to 885MHz	Pin = 7dBm, V _{DD} = 2.8 to 3.0V	17	19		dB
	RF5-RF1	810 to 885MHz	Pin = 7dBm, V _{DD} = 2.8 to 3.0V	27	34		dB
	RF5-RF6	810 to 885MHz	Pin = 7dBm, V _{DD} = 2.8 to 3.0V	20	25		dB
VSWR	Each ON Port	810 to 960MHz				1.4	
ACP (±50kHz)	RF3-RF2	889 to 960MHz	Pin = 29.5dBm, V _{DD} = 3.0V*1		-67	-57	dBc
	RF3-RF4		Pin = 29.5dBm, V _{DD} = 2.8V*1		-67	-55	dBc
ACP (±100kHz)	RF3-RF2	889 to 960MHz	Pin = 29.5dBm, V _{DD} = 3.0V*1		-75	-65	dBc
	RF3-RF4		Pin = 29.5dBm, V _{DD} = 2.8V*1		-75	-62	dBc
2nd harmonics	RF3-RF2	889 to 960MHz	Pin = 29.5dBm, V _{DD} = 3.0V*1		-67	-60	dBc
	RF3-RF4		Pin = 29.5dBm, V _{DD} = 2.8V*1		-67	-57	dBc
3rd harmonics	RF3-RF2	889 to 960MHz	Pin = 29.5dBm, V _{DD} = 3.0V*1		-67	-60	dBc
	RF3-RF4		Pin = 29.5dBm, V _{DD} = 2.8V*1		-67	-57	dBc
Control current					85	150	μA
Bias current			V _{DD} = 3.0V		0.45	1	mA
			V _{DD} = 2.8V		0.4	0.9	mA
Switching speed					1.0	5.0	μs

*1 Input Signal: ACP (±50kHz) < -65dBc, ACP (±100kHz) < -75dBc,
2nd harmonics < -65dBc, 3rd harmonics < -65dBc

Package Outline

Unit: mm

16PIN TSSOP (PLASTIC)

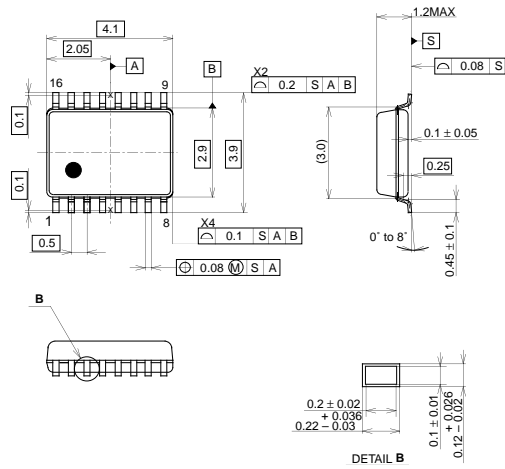

SONY CODE	TSSOP-16P-L01
EIAJ CODE	_____
JEDEC CODE	_____

PACKAGE STRUCTURE	
PACKAGE MATERIAL	EPOXY RESIN
LEAD TREATMENT	SOLDER PLATING
LEAD MATERIAL	COPPER ALLOY
PACKAGE MASS	0.03g

16PIN TSSOP (PLASTIC)

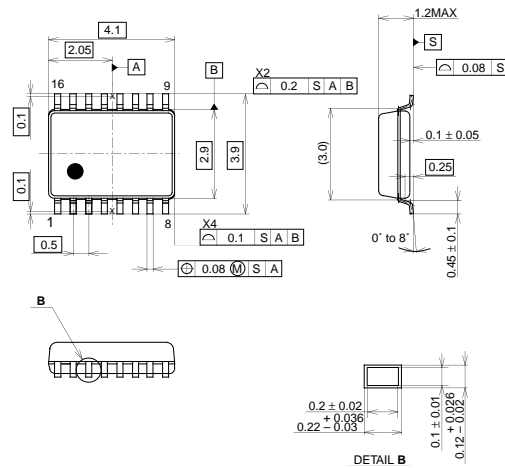

SONY CODE	TSSOP-16P-L01
EIAJ CODE	_____
JEDEC CODE	_____

PACKAGE STRUCTURE	
PACKAGE MATERIAL	EPOXY RESIN
LEAD TREATMENT	SOLDER PLATING
LEAD MATERIAL	COPPER ALLOY
PACKAGE MASS	0.03g

LEAD PLATING SPECIFICATIONS

ITEM	SPEC.
LEAD MATERIAL	COPPER ALLOY
SOLDER COMPOSITION	Sn-Bi Bi:1-4wt%
PLATING THICKNESS	5-18µm