



FEATURES

- In-phase and quadrature output
- Full 5-watt output
- Short circuit and overload protection
- Thermal cutoff protection
- Integral heat sinking

APPLICATIONS

- Synchro/Resolver excitation
- Inductosyn™ excitation
- LVDT excitation

GENERAL DATA

The series 110A100 is a 5 watt oscillator packaged in a 2.62" x 3.12" x .8" module capable of delivering 5 watts. An aluminum top surface provides all the necessary heat sinking.

The device is made up of three parts; a quadrature oscillator, power amplifier, and an output transformer. The oscillator stage has two signal outputs, one 90 degree phase advanced with respect to the other. Both outputs have an amplitude of 2.5Vrms. Four standard voltages and frequencies are offered. Other voltages and frequencies available on special order.

The power amplifier stage is short circuit and overload protected and also contains a thermal shutdown feature. The power output can be varied in amplitude plus or minus 10% by means of an internal potentiometer which is accessible to the user.

HEATSINKING AND THERMAL PROTECTION

The top of the 110A100 consists of an aluminum plate and provides all the required heat sinking provided there is sufficient air circulation. Thermal resistance top plate to free air is 15 degrees C/watt. The thermal resistance of the top plate may be improved by a factor of three or greater by simply blowing air of sufficient velocity over the plate.

A thermal cutout is incorporated that disables the output power amplifier when the top plate reaches 150 to 170 degrees C, dependent on load. It starts operating again when the heat sink temperature drops to about 125 degrees C, but if the temperature again begins to rise, shutdown will occur at only 130 degrees C. Therefore, the power amplifier is allowed to heat up to relatively high temperature if a fault condition is temporary, but if a sustained fault occurs the maximum temperature is limited to a lower value. This method of thermal cutout greatly reduces stress on the power amplifier, which in turn improved reliability.

SPECIFICATIONS

Parameter	Value
Frequency	
Range ⁽¹⁾	400Hz - 10KHz
Stability ⁽²⁾	± 5%
Outputs	
REF 1	2.5Vrms ± 5% @ 3mA max. In-phase with RH-RL
REF 2	2.5Vrms ± 5% @ 3mA max. 90 phase advanced
RH-RL ⁽¹⁾	6 - 115Vrms @ 5 watts max.
Power Supplies	
Voltage	± 15V ± 10%
Current	50mA + load
Temperature Range	
Operating	0 to 70°C
Storage	-55 to 125°C
Size	2.62" x 3.12" x 0.8"
Weight	7.0 Oz.

NOTES

1. See ordering information
2. Over full operating temperature range

MECHANICAL OUTLINE

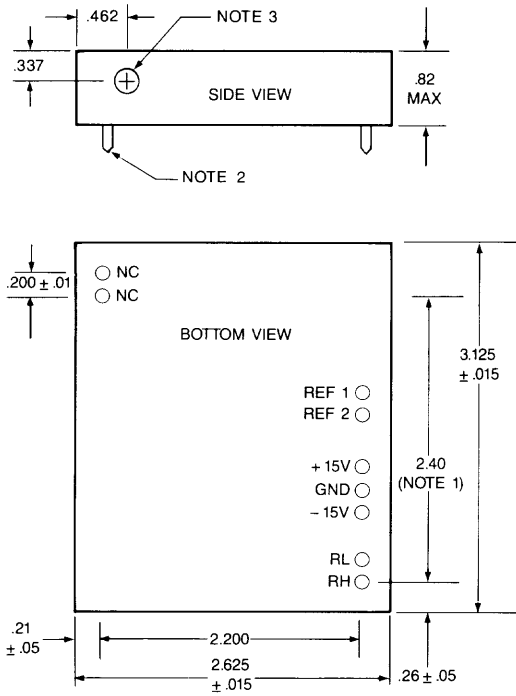

NOTES

1. Non-cumulative
2. Rigid 0.040 diameter pins suitable for solder-in or plug-in applications.
3. Gain adjustment access.
4. Dimensions are in inches.

POWER OSCILLATOR BLOCK DIAGRAM

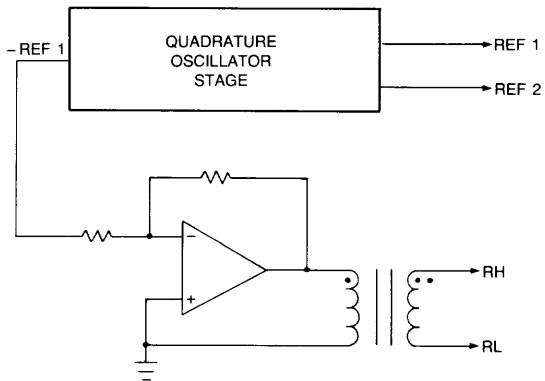

ORDERING INFORMATION

110A Suffix	Output Voltage	Frequency
100	6V	400Hz
101	12V	400Hz
102	26V	400Hz
103	115V	400Hz
104	6V	1.0KHz
105	12V	1.0KHz
106	6V	2.6KHz
107	12V	2.6KHz
108	6V	5.0KHz
109	12V	5.0KHz
110	6V	10.0KHz
111	12V	10.0KHz

Additional voltages and frequencies may be specified, consult factory.