

13-Input NAND Gate

Product Specification

Military Logic Products

FUNCTION TABLE

INPUTS	OUTPUT
A . . . M	Y
H . . . H one input = L	L H

H = High voltage level
L = Low voltage level

ORDERING INFORMATION

DESCRIPTION	ORDER CODE
Ceramic DIP	54S133/BEA
Ceramic Flat Pack	54S133BFBA
Ceramic LLCC	54S133/B2A

INPUT AND OUTPUT LOADING AND FAN-OUT TABLE

PINS	DESCRIPTION	54S
All	Inputs	1SUL
Y	Output	10SUL

NOTE: Where a 54S Unit Load (SUL) is 50 μ A I_{IH} and -2.0mA I_{IL} .

ABSOLUTE MAXIMUM RATINGS (Over operating free-air temperature range unless otherwise noted.)

SYMBOL	PARAMETER	RATING	UNIT
V_{CC}	Supply voltage	7.0	V
V_I	Input voltage range	-0.5 to +5.5	V
I_I	Input current range	-30 to +5	mA
V_O	Voltage applied to output in High output state range	-0.5 to + V_{CC}	V
T_{STG}	Storage temperature range	-65 to +150	$^{\circ}$ C

PIN CONFIGURATION

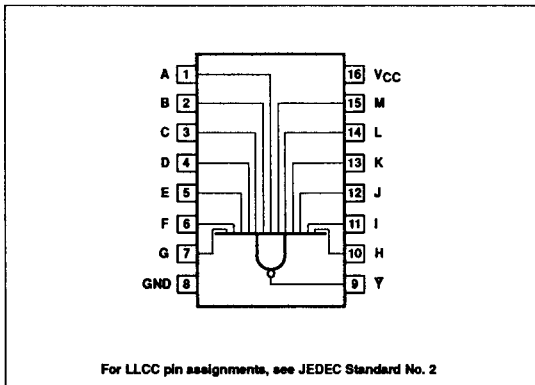

LOGIC SYMBOL

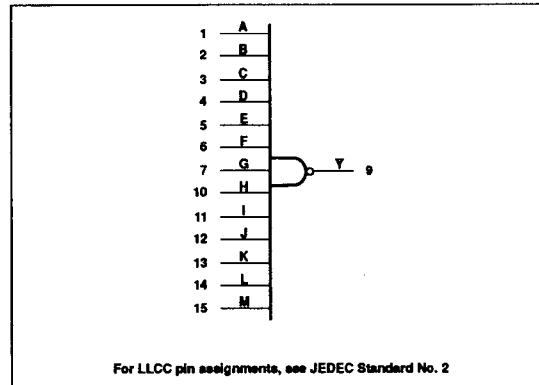

Gate

54S133

RECOMMENDED OPERATING CONDITIONS

SYMBOL	PARAMETER	LIMITS			UNIT
		Min	Nom	Max	
V _{CC}	Supply voltage	4.5	5.0	5.5	V
V _{IH}	High-level input voltage	2.0			V
V _{IL}	Low-level input voltage			+0.8	V
		+125°C		+0.7	V
I _{IK}	Input clamp current			-18	mA
I _{OH}	High-level output current			-1000	μA
I _{OL}	Low-level output current			20	mA
T _A	Operating free-air temperature range	-55		+125	°C

DC ELECTRICAL CHARACTERISTICS (Over recommended operating free-air temperature range unless otherwise noted.)

SYMBOL	PARAMETER	TEST CONDITIONS ¹	LIMITS			UNIT
			Min	Typ ²	Max	
V _{OH}	High-level output voltage	V _{CC} = Min, V _{IL} = Max, I _{OH} = Max	2.4	3.4		V
V _{OL}	Low-level output voltage	V _{CC} = Min, V _{IH} = Min,			0.5	V
		I _{OL} = Max			0.45	V
V _{IK}	Input clamp voltage	V _{CC} = Min, I _I = I _{IK}			-1.2	V
I _{IH2}	Input current at maximum input voltage	V _{CC} = Max, V _I = 5.5V			1.0	mA
I _{IH1}	High-level input current	V _{CC} = Max, V _I = 2.7V			50	μA
I _{IL}	Low-level input current	V _{CC} = Max, V _I = 0.5V			-2.0	mA
I _{OS}	Short-circuit output current ³	V _{CC} = Max	-40		-110	mA
I _{CC}	Supply current (total)	V _{CC} = Max	I _{CCH} Outputs High	3	5	mA
			I _{CCL} Outputs Low	5.5	10	mA

AC ELECTRICAL CHARACTERISTICS T_A = 25°C, V_{CC} = 5.0V

SYMBOL	PARAMETER	TEST CONDITIONS	LIMITS		UNIT
			C _L = 15pF		
			Min	Max	
t _{PLH} t _{PHL}	Propagation delay	Waveform 1		6.0	ns
				7.0	ns

AC ELECTRICAL CHARACTERISTICS T_A = 25°C, V_{CC} = 5.0V⁴

SYMBOL	PARAMETER	TEST CONDITIONS	LIMITS		UNIT
			C _L = 50pF		
			Min	Max	
t _{PLH} t _{PHL}	Propagation delay	Waveform 1		8.5	ns
				9.5	ns

Gate

54S133

AC ELECTRICAL CHARACTERISTICS $T_A = -55^{\circ}\text{C}$ and $+125^{\circ}\text{C}$, $V_{CC} = 5.0\text{V}^4$

SYMBOL	PARAMETER	TEST CONDITIONS	LIMITS		UNIT
			$C_L = 50\text{pF}$		
			Min	Max	
t_{PLH} t_{PHL}	Propagation delay	Waveform 1		11.0 12.0	ns ns

NOTES:

1. For conditions shown as Min or Max, use the appropriate value specified under recommended operating conditions for the applicable type and function table operating mode.
2. All typical values are at $V_{CC} = 5\text{V}$, $T_A = 25^{\circ}\text{C}$.
3. Not more than one output should be shorted at a time and duration of the short circuit should not exceed one second.
4. These parameters are guaranteed, but not tested.

AC WAVEFORM

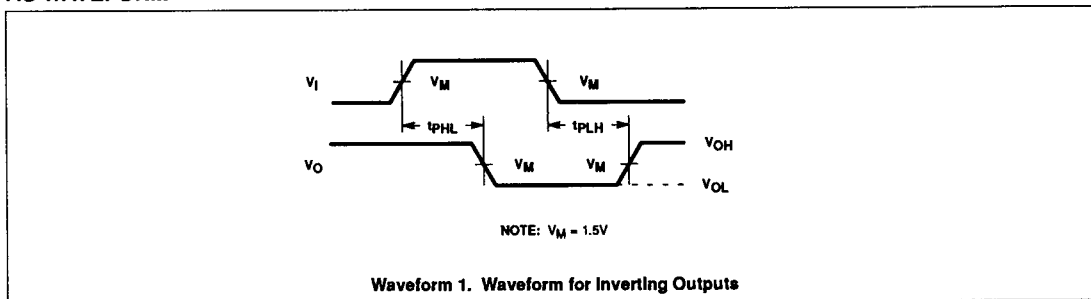

TEST CIRCUIT AND WAVEFORM

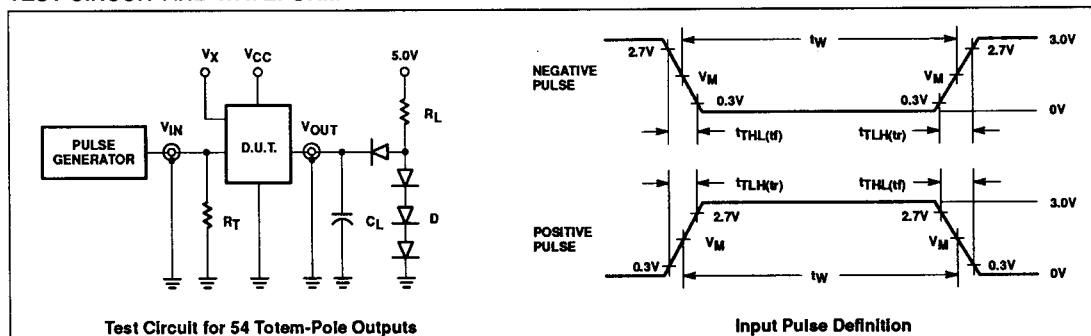

FAMILY	INPUT PULSE CHARACTERISTICS					
	R_L	V_M	Rep. Rate	T_W	T_{TLH}	T_{THL}
54SXXX	280 Ω	1.5V	1MHz	500ns	$\leq 2.5\text{ns}$	$\leq 2.5\text{ns}$

DEFINITIONS:

- C_L = Load capacitance includes jig and probe capacitance; see AC Characteristics for value.
- R_T = Termination resistance should be equal to Z_{OUT} of Pulse Generators.
- D = Diodes are 1N916, 1N3064, or equivalent.
- V_X = Unlocked pins must be held at $\leq 0.8\text{V}$, $\geq 2.7\text{V}$ or open per Function Table.