

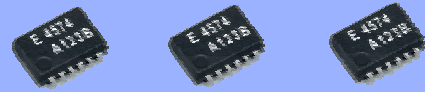

Small size, low profile model package SERIAL-INTERFACE REAL TIME CLOCK MODULE

RX - 4574 LC

- Built in frequency adjusted 32.768 kHz crystal unit.
- Interface Type : 3-wire serial interface
- Operating voltage range : 1.6 V to 5.5 V
- Wide Timekeeper voltage range : 1.3 V to 5.5 V
- Low backup current : 0.35 μ A / 3 V (Typ.)
- 32.768 kHz frequency output function : C-MOS output With Control Pin
- The various functions include full calendar, alarm, timer.



Actual size



Block diagram

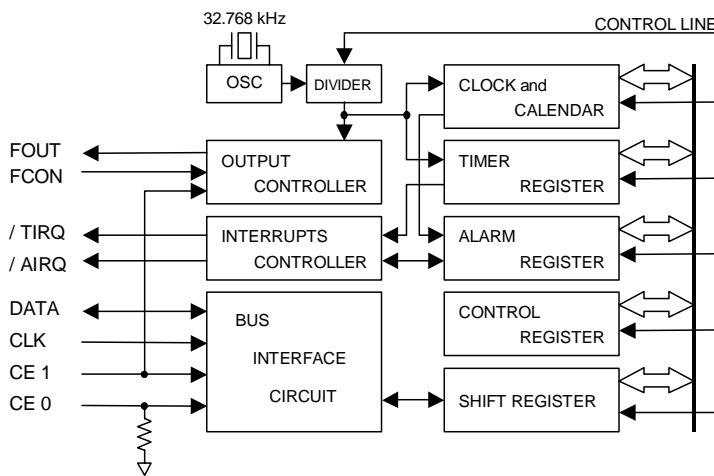

Overview

- **32.768 kHz frequency output function**
 - FOUT pin output (C-MOS output), CL=30 pF
 - Output frequency is selectable from 1/30 Hz to 32.768 kHz (32 Values)
 - **Timer function**
 - Timer function which can be set up between 1/4096 second and 255 minutes.
 - It is recorded automatically to TF-bit at the time of event occurrence, and it's possible to output with /TIRQ pin output (open-drain output).
 - Selectable one time mode or repeat mode.
 - **Alarm function**
 - Alarm function can be set to any combination of day of week, hour, or minute.
 - It is recorded automatically to AF-bit at the time of event occurrence, and it's possible to output with /AIRQ pin output (open-drain output).
- * Functions are compatible with RTC-4574 SA / JE / NB.

Pin Function

Signal Name	Input / Output	Function
CE0	Input	The chip enabled input pin 0. (Built-in pull-down resistance) When both CE0 and CE1 pins are at the "H" level, access to this Real time clock module becomes possible.
CE1	Input	The chip enabled input pin 1. When the CE1 pin is at the HIGH level, the FOUT pin is in the output state.
CLK	Input	The shift clock input pin for serial data transfer.
DATA	Bi-directional	The data input / output pin for serial data transfer.
FOUT	Output	This pin outputs the reference clock signal at 32.768 kHz (C-MOS output). High impedance at the time of output off.
FCON	Input	The input pin for the FOUT output control.
/ AIRQ	Output	The open drain output pin for alarm and time update interrupts.
/ TIRQ	Output	The open drain output pin for timer interrupt.
VDD	—	Connected to a positive power supply.
GND	—	Connected to a ground.

Terminal connection / External dimensions (Unit:mm)

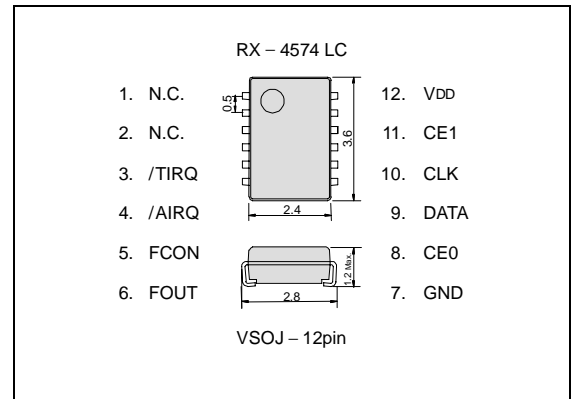

Specifications (characteristics)

* Refer to application manual for details.

Recommended Operating Conditions

Item	Symbol	Condition	Min.	Typ.	Max.	Unit
Power voltage	VDD	—	1.6	3.0	5.5	V
Clock voltage	VCLK	—	1.3	3.0	5.5	V
Operating temperature	TOPR	—	-40	+25	+85	°C

Frequency characteristics

Item	Symbol	Condition	Rating	Unit
Frequency tolerance	$\Delta f/f$	Ta = +25 °C VDD = 3.0 V	5 ± 23 *	$\times 10^{-6}$
Oscillation Start-up time	tSTA	Ta = +25 °C VDD = 1.6 V	1 Max.	s
		Ta = -40 °C to +85 °C VDD = 1.6 V	3 Max.	s

*Equivalent to 1 minute of monthly deviation

Current consumption characteristics

Ta = -40 °C to +85 °C

Item	Symbol	Condition	Min.	Typ.	Max.	Unit
Current Consumption	I _{BK}	CE0, CE1 = GND FOUT ;output OFF (Hi - z)	VDD = 5 V	0.45	0.9	μ A
			VDD = 3 V	0.35	0.7	
	I _{32k}	CE0 = GND CE1 = VDD FOUT ; 32.768 kHz output ON CL = 30 pF	VDD = 5 V	8.0	20.0	μ A
			VDD = 3 V	5.0	12.0	