

EH26 Series

- Pb-free Ceramic SMD package
- 3.3V supply voltage
- LVHCMOS output
- Stability to 20ppm
- Available on tape and reel

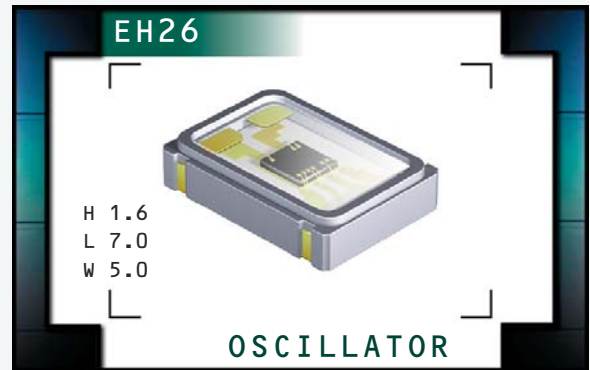

NOTES

ELECTRICAL SPECIFICATIONS

Frequency Range		1.000MHz to 155.520MHz
Operating Temperature Range		0°C to 70°C or -40°C to 85°C
Storage Temperature Range		-55°C to 125°C
Supply Voltage (V_{DD})		3.3V _{DC} ±0.3V _{DC}
Input Current		35mA Maximum (Unloaded)
Frequency Tolerance / Stability	Inclusive of all conditions: Calibration Tolerance at 25°C, Frequency Stability over the Operating Temperature Range, Supply Voltage Change, Output Load Change, First Year Aging at 25°C, Shock, and Vibration	±100ppm, ±50ppm, ±25ppm, or ±20ppm Maximum
Output Voltage Logic High (V_{OH})		2.7V _{DC} Minimum I _{OH} = -8mA
Output Voltage Logic Low (V_{OL})		0.5V _{DC} Maximum I _{OL} = +8mA
Rise Time / Fall Time	≤70.000MHz 20% to 80% of Waveform w/HCMOS Load >70.000MHz 20% to 80% of Waveform w/HCMOS Load	6 nSeconds Maximum 4 nSeconds Maximum
Load Drive Capability	≤70.000MHz >70.000MHz	30pF HCMOS Load Maximum 15pF HCMOS Load Maximum
Duty Cycle (at V_{DD}=3.3V_{DC})	at 50% of Waveform	50 ±10(%) (Standard) or 50 ±5(%) (Optional)
Tri-State Input Voltage	V _{IH} : No Connection or ≥2.2V _{DC} V _{IL} : ≤0.8V _{DC}	Enables Output Disables Output: High Impedance
Aging (at 25°C)		±5ppm / year Maximum
Start Up Time		10mSeconds Maximum
Period Jitter: Absolute		±250pSec Maximum, ±100pSec Typical
Period Jitter: One Sigma		±50pSec Maximum, ±40pSec Typical

MANUFACTURER ECLIPTEK CORP.	CATEGORY OSCILLATOR	SERIES EH26	PACKAGE CERAMIC	VOLTAGE 3.3V	CLASS OS48	REV. DATE 02/04
--------------------------------	------------------------	----------------	--------------------	-----------------	---------------	--------------------

PART NUMBERING GUIDE

EH26 00 ET TS - 24.000M TR

FREQUENCY TOLERANCE / STABILITY

00=±100ppm Maximum (Standard), 45=±50ppm Maximum,
25=±25ppm Maximum, 20=±20ppm Maximum

OPERATING TEMP. RANGE

Blank=0°C to 70°C or
ET=-40°C to 85°C

DUTY CYCLE

Blank=50 ±10% (Standard)
T=50 ±5%

AVAILABLE OPTIONS

Blank=Bulk (Standard)
TR=Tape and Reel

FREQUENCY

OUTPUT CONTROL FUNCTION

TS=Tri-State

MECHANICAL DIMENSIONS

ALL DIMENSIONS IN MILLIMETERS

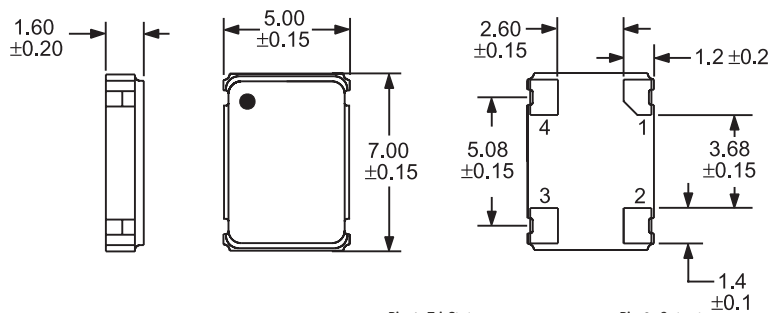

Pin 1: Tri-State
Pin 2: Case Ground

Pin 3: Output
Pin 4: Supply Voltage

SUGGESTED SOLDER PAD LAYOUT

ALL DIMENSIONS IN MILLIMETERS

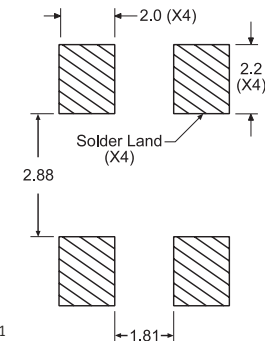

Tolerances= ±0.1

TAPE AND REEL DIMENSIONS

ALL DIMENSIONS IN MILLIMETERS

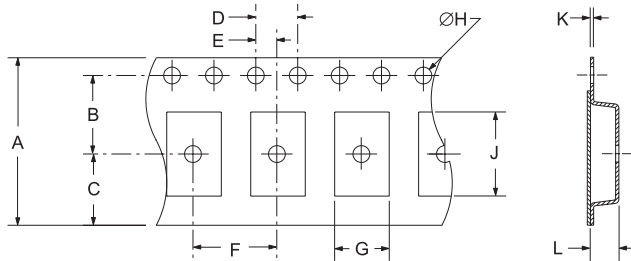

REEL	A	B	C	D	E
	16+3-1	7.5±1	6.75±1	4±1	2±1
F	G	H	J	K	L
8±1	B0*	1.5+1-0	A0*	.3±.05	K0*

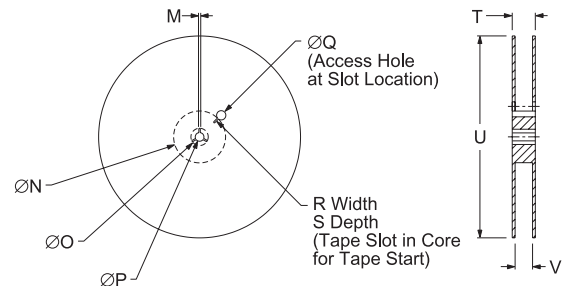

REEL	M	N	O	P	Q
	1.5 MIN	50 MIN	20.2 MIN	13±.2	40 MIN
R	S	T	U	V	QTY/REEL
2.5 MIN	10 MIN	22.4 MAX	360 MAX	16.4+2-0	1,000

*Compliant to EIA 481A

ENVIRONMENTAL/MECHANICAL SPECIFICATIONS

Characteristic	Specification
Fine Leak Test	MIL-STD-883, Method 1014, Condition A
Gross Leak Test	MIL-STD-883, Method 1014, Condition C
Mechanical Shock	MIL-STD-202, Method 213, Condition C
Vibration	MIL-STD-883, Method 2007, Condition A
Lead Integrity	MIL-STD-883, Method 2004
Solderability	MIL-STD-883, Method 2002
Temperature Cycling	MIL-STD-883, Method 1010
Resistance to Soldering Heat	MIL-STD-883, Method 210
Resistance to Solvents	MIL-STD-883, Method 215

MARKING SPECIFICATIONS

Line 1: ECLIPTEK

Line 2: XX.XXX M
Frequency in MHz (5 Digits Maximum + Decimal)

Line 3: P XX Y ZZ
 P: Week of Year
 XX: Last Digit of Year
 Y: Ecliptek Manufacturing Identifier
 ZZ: Configuration Designator

MANUFACTURER	CATEGORY	SERIES	PACKAGE	VOLTAGE	CLASS	REV. DATE
ECLIPTEK CORP.	OSCILLATOR	EH26	CERAMIC	3.3V	OS48	02/04