



## DS8884A High Voltage Cathode Decoder/Driver

### General Description

The DS8884A is designed to decode four lines of BCD input and drive seven-segment digits of gas-filled readout displays.

All outputs consist of switchable and programmable current sinks which provide constant current to the tube cathodes, even with high tube anode supply tolerance. Output currents may be varied over the 0.2 mA to 1.2 mA range for multiplex operation. The output current is adjusted by connecting an external program resistor ( $R_p$ ) from  $V_{CC}$  to the program input in accordance with the programming curve. Unused outputs must be tied to  $V_{CC}$ .

### Features

- Usable with AC or DC input coupling
- Current sink outputs
- High output breakdown voltage
- Low input load current
- Intended for multiplex operation
- Input pullups increase noise immunity
- Comma/d.pt. drive

### Connection Diagram

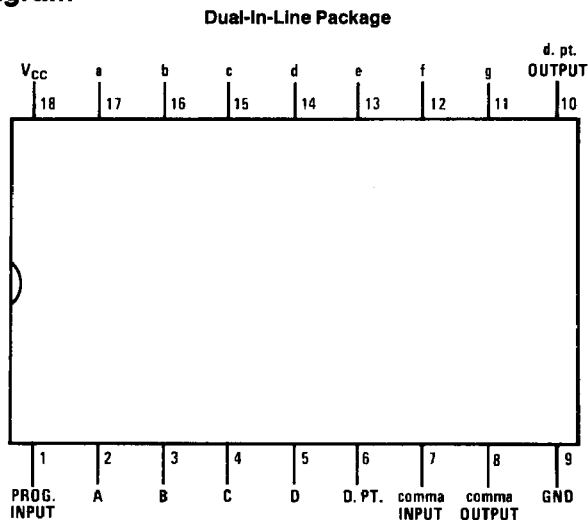

Order Number DS8884AN  
See NS Package Number N18A

TL/F/5847-2

## Absolute Maximum Ratings (Note 1)

If Military/Aerospace specified devices are required, please contact the National Semiconductor Sales Office/Distributors for availability and specifications.

|                                           |                 |
|-------------------------------------------|-----------------|
| V <sub>CC</sub>                           | 7V              |
| Input Voltage (Note 4)                    | V <sub>CC</sub> |
| Segment Output Voltage                    | 80V             |
| Power Dissipation                         | 600 mW          |
| Transient Segment Output Current (Note 5) | 50 mA           |

|                                                |                        |  |
|------------------------------------------------|------------------------|--|
| Storage Temperature Range                      | -65°C to +150°C        |  |
| Maximum Power Dissipation* at 25°C             | Molded Package 1714 mW |  |
| *Derate molded package 13.71 mW/°C above 25°C. |                        |  |

## Operating Conditions

|                                   | Min  | Max  | Units |
|-----------------------------------|------|------|-------|
| Supply Voltage (V <sub>CC</sub> ) | 4.75 | 5.25 | V     |
| Temperature (T <sub>A</sub> )     | 0    | +70  | °C    |

## Electrical Characteristics (Notes 2 and 3)

| Symbol            | Parameter                                        | Conditions                                                            | Min                    | Max  | Units |    |
|-------------------|--------------------------------------------------|-----------------------------------------------------------------------|------------------------|------|-------|----|
| V <sub>IH</sub>   | Logical "1" Input Voltage                        | V <sub>CC</sub> = 4.75V                                               | 2.0                    |      | V     |    |
| V <sub>IL</sub>   | Logical "0" Input Voltage                        | V <sub>CC</sub> = 4.75V                                               |                        | 1.0  | V     |    |
| I <sub>IH</sub>   | Logical "1" Input Current                        | V <sub>CC</sub> = 5.25V, V <sub>IN</sub> = 2.4V                       |                        | 15   | μA    |    |
| I <sub>IL</sub>   | Logical "0" Input Current                        | V <sub>CC</sub> = 5.25V, V <sub>IN</sub> = 0.4V                       |                        | -250 | μA    |    |
| I <sub>CC</sub>   | Power Supply Current                             | V <sub>CC</sub> = 5.25V, R <sub>P</sub> = 2.8k, All Inputs = 5V       |                        | 40   | mA    |    |
| V <sub>I+</sub>   | Positive Input Clamp Voltage                     | V <sub>CC</sub> = 4.75V, I <sub>IN</sub> = 1 mA                       | 5.0                    |      | V     |    |
| V <sub>I-</sub>   | Negative Input Clamp Voltage                     | V <sub>CC</sub> = 5V, I <sub>IN</sub> = -12 mA, T <sub>A</sub> = 25°C |                        | -1.5 | V     |    |
| ΔI <sub>O</sub>   | SEGMENT OUTPUTS "ON" Current Ratio               | All Outputs = 50V, I <sub>OUT b</sub> = Ref., All Outputs             | 0.9                    | 1.1  |       |    |
| I <sub>b ON</sub> | Output b "ON" Current                            | V <sub>CC</sub> = 5V, V <sub>OUT b</sub> = 50V, T <sub>A</sub> = 25°C | R <sub>P</sub> = 18.1k | 0.15 | 0.25  | mA |
|                   |                                                  |                                                                       | R <sub>P</sub> = 7.03k | 0.45 | 0.55  | mA |
|                   |                                                  |                                                                       | R <sub>P</sub> = 3.40k | 0.90 | 1.10  | mA |
|                   |                                                  |                                                                       | R <sub>P</sub> = 2.80k | 1.08 | 1.32  | mA |
| I <sub>CEX</sub>  | Output Leakage Current                           | V <sub>OUT</sub> = 75V                                                |                        | 5    | μA    |    |
| V <sub>BR</sub>   | Output Breakdown Voltage                         | I <sub>OUT</sub> = 250 μA                                             | 80                     |      | V     |    |
| t <sub>pd</sub>   | Propagation Delay of Any Input to Segment Output | V <sub>CC</sub> = 5V, T <sub>A</sub> = 25°C                           |                        | 10   | μs    |    |

**Note 1:** "Absolute Maximum Ratings" are those values beyond which the safety of the device cannot be guaranteed. They are not meant to imply that the devices should be operated at these limits. The table of "Electrical Characteristics" provides conditions for actual device operation.

**Note 2:** Unless otherwise specified min/max limits apply across the 0°C to +70°C temperature range for the DS8884A. All typical values are for T<sub>A</sub> = 25°C and V<sub>CC</sub> = 5V.

**Note 3:** All currents into device pins shown as positive, out of device pins as negative, all voltages referenced to ground unless otherwise noted. All values shown as max or min on absolute value basis.

**Note 4:** This limit can be higher for a current limiting voltage source.

**Note 5:** In all applications transient segment output current must be limited to 50 mA. This may be accomplished in DC applications by connecting a 2.2k resistor from the anode-supply filter capacitor to the display anode, or by current limiting the anode driver in multiplex applications.

## Typical Application

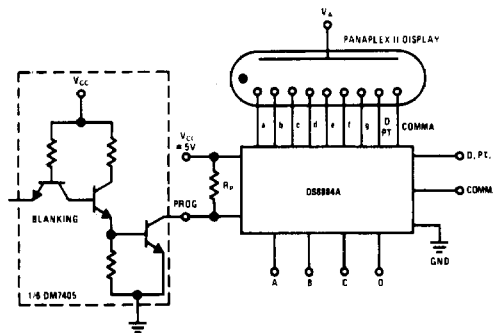

TL/F/5847-4

# Truth Table

| FUNCTION | D.P.T. | COMMA | D | C | B | A | a | b | c | d | e | f | g | DISPLAY |
|----------|--------|-------|---|---|---|---|---|---|---|---|---|---|---|---------|
| 0        | 1      | 1     | 0 | 0 | 0 | 0 | 0 | 0 | 0 | 0 | 0 | 0 | 1 | 0       |
| 1        | 1      | 1     | 0 | 0 | 0 | 1 | 1 | 0 | 0 | 1 | 1 | 1 | 1 | 1       |
| 2        | 1      | 1     | 0 | 0 | 1 | 0 | 0 | 0 | 1 | 0 | 0 | 1 | 0 | 0       |
| 3        | 1      | 1     | 0 | 0 | 1 | 1 | 0 | 0 | 0 | 0 | 1 | 1 | 0 | 0       |
| 4        | 1      | 1     | 0 | 1 | 0 | 0 | 1 | 0 | 0 | 1 | 1 | 0 | 0 | 0       |
| 5        | 1      | 1     | 0 | 1 | 0 | 1 | 0 | 1 | 0 | 0 | 1 | 0 | 0 | 0       |
| 6        | 1      | 1     | 0 | 1 | 1 | 0 | 0 | 1 | 0 | 0 | 0 | 0 | 0 | 0       |
| 7        | 1      | 1     | 0 | 1 | 1 | 1 | 0 | 0 | 0 | 1 | 1 | 1 | 1 | 1       |
| 8        | 1      | 1     | 1 | 0 | 0 | 0 | 0 | 0 | 0 | 0 | 0 | 0 | 0 | 0       |
| 9        | 1      | 1     | 1 | 0 | 0 | 1 | 0 | 0 | 0 | 0 | 1 | 0 | 0 | 0       |
| 10       | 1      | 1     | 1 | 0 | 1 | 0 | 1 | 1 | 0 | 0 | 0 | 1 | 1 | 1       |
| 11       | 1      | 1     | 1 | 0 | 1 | 1 | 1 | 1 | 0 | 0 | 0 | 1 | 0 | 0       |
| 12       | 1      | 1     | 1 | 1 | 0 | 0 | 0 | 0 | 1 | 1 | 1 | 0 | 0 | 0       |
| 13       | 1      | 1     | 1 | 1 | 0 | 1 | 0 | 1 | 1 | 0 | 0 | 0 | 0 | 0       |
| 14       | 1      | 1     | 1 | 1 | 1 | 0 | 1 | 1 | 1 | 1 | 1 | 1 | 1 | 0       |
| 15       | 1      | 1     | 1 | 1 | 1 | 1 | 1 | 1 | 1 | 1 | 1 | 1 | 1 | 1       |
| *D.P.T.  | 0      | 1     | X | X | X | X | X | X | X | X | X | X | X | .       |
| *Comma   | 0      | 0     | X | X | X | X | X | X | X | X | X | X | X | ,       |

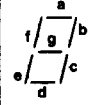

Decimal Point  
 Comma

\*Decimal point and comma can be displayed with or without any numeral.

TL/F/5847-3

# Logic Diagram

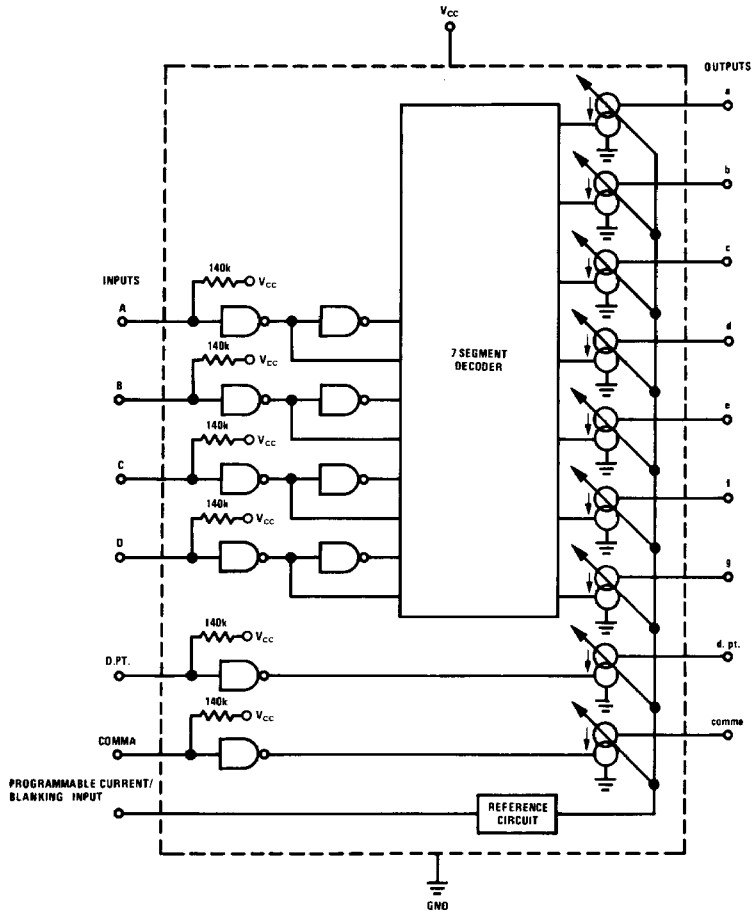

TL/F/5847-1