

PBL 3775

Dual Stepper Motor Driver

Description

The PBL 3775 is a switch-mode (chopper), constant-current driver IC with two channels, one for each winding of a two-phase stepper motor. The circuit is similar to Ericsson's PBL 3773. While several of Ericsson's dual stepper motor drivers are optimized for micro-stepping applications, PBL 3775 is equipped with a disable input to simplify half-stepping operation.

The PBL 3775 contains a clock oscillator, which is common for both driver channels, a set of comparators and flip-flops implementing the switching control, and two output H-bridges, including recirculation diodes.

Voltage supply requirements are + 5 V for logic and + 10 to + 45 V for the motor.

The close match between the two driver channels guarantees consistent output current ratios and motor positioning accuracy.

Key Features

- Dual chopper driver in a single package.
- - 40° C to + 85° C operation.
- 750 mA continuous output current per channel.
- Low power dissipation, 2.0 W at 2 x 500 mA output current.
- Close matching between channels for high microstepping accuracy.
- Digital filter on chip eliminates external filtering components.
- Plastic 22-pin batwing DIP package or 28-pin power PLCC with lead-frame for heat-sinking through PC board copper.

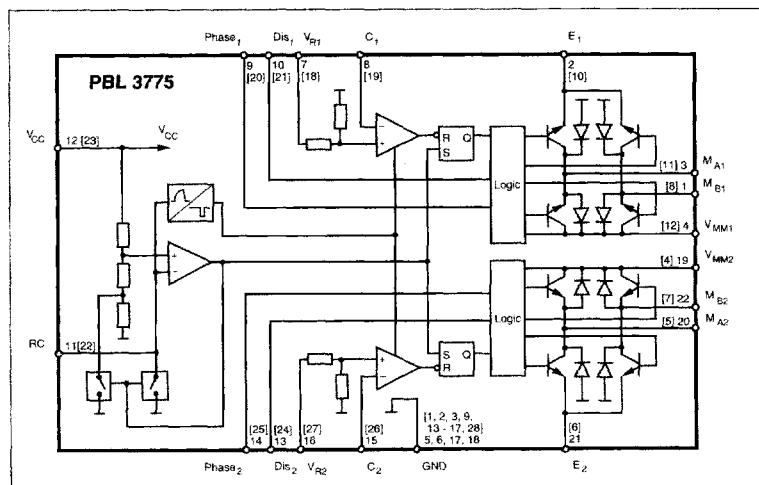
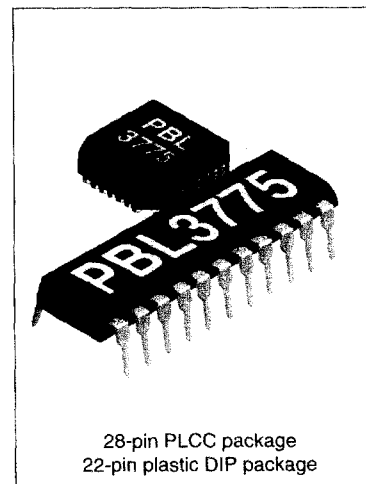

Figure 1. Block diagram.



28-pin PLCC package
22-pin plastic DIP package

Electrical Characteristics

Electrical characteristics over recommended operating conditions, unless otherwise noted. $-20^{\circ}\text{C} \leq T_A \leq +125^{\circ}\text{C}$.

Parameter	Symbol	Ref. fig.	Conditions	Min	Typ	Max	Unit
General							
Supply current	I_{CC}	2	Note 4.		55	70	mA
Supply current	I_{CC}	2	$Dis_1 = Dis_2 = \text{HIGH}$.		7	10	mA
Total power dissipation	P_D	8	$V_{MM} = 24\text{ V}$, $I_{M1} = I_{M2} = 500\text{ mA}$. Notes 2, 3, 4.		2.0	2.3	W
Total power dissipation	P_D	8	$V_{MM} = 24\text{ V}$, $I_{M1} = 700\text{ mA}$, $I_{M2} = 0\text{ mA}$. Notes 2, 3, 4.		1.7	2.0	W
Thermal shutdown junction temperature					160		$^{\circ}\text{C}$
Turn-off delay	t_d	3	$T_A = +25^{\circ}\text{C}$, $dV_C/dt \geq 50\text{ mV}/\mu\text{s}$, $I_M = 100\text{ mA}$. Note 3.		1.1	2.0	μs
Logic Inputs							
Logic HIGH input voltage	V_{IH}	2		2.0			V
Logic LOW input voltage	V_{IL}	2				0.6	V
Logic HIGH input current	I_{IH}	2	$V_I = 2.4\text{ V}$			20	μA
Logic LOW input current	I_{IL}	2	$V_I = 0.4\text{ V}$	-0.2	-0.1		mA
Analog Inputs							
Threshold voltage	V_{CH}	2	$V_R = 5\text{ V}$	480	500	520	mV
Input current	I_A	2	$V_R = 5\text{ V}$		500		μA
$ V_{C1} - V_{C2} $ mismatch	V_{Cdiff}	2			1		mV
Motor Outputs							
Lower transistor saturation voltage		10	$I_M = 500\text{ mA}$		0.4	0.8	V
Lower transistor leakage current		2	$V_{MM} = 41\text{ V}$, $T_A = +25^{\circ}\text{C}$. $Dis_1 = Dis_2 = \text{HIGH}$.			100	μA
Lower diode forward voltage drop		11	$I_M = 500\text{ mA}$		1.1	1.3	V
Upper transistor saturation voltage		12	$I_M = 500\text{ mA}$		1.1	1.4	V
Upper diode forward voltage drop		13	$I_M = 500\text{ mA}$		1.1	1.4	V
Upper transistor leakage current		2	$V_{MM} = 41\text{ V}$, $T_A = +25^{\circ}\text{C}$. $Dis_1 = Dis_2 = \text{HIGH}$.			100	μA
Chopper Oscillator							
Chopping frequency	f_s	3	$C_T = 4\text{ 700 pF}$, $R_T = 12\text{ kohm}$	21.5	23.0	24.5	kHz
Digital filter blanking time	t_b	3	$C_T = 4\text{ 700 pF}$. Note 3.		1.0		μs

Thermal Characteristics

Parameter	Symbol	Ref. fig.	Conditions	Min	Typ	Max	Unit
Thermal resistance	$R_{th\ J-BW}$		DIP package.		11		$^{\circ}\text{C}/\text{W}$
	$R_{th\ J-A}$	14	DIP package. Note 2.		40		$^{\circ}\text{C}/\text{W}$
	$R_{th\ J-BW}$		PLCC package.		9		$^{\circ}\text{C}/\text{W}$
	$R_{th\ J-A}$	14	PLCC package. Note 2.		35		$^{\circ}\text{C}/\text{W}$

Notes

- All voltages are with respect to ground. Currents are positive into, negative out of specified terminal.
- All ground pins soldered onto a 20 cm^2 PCB copper area with free air convection, $T_A = +25^{\circ}\text{C}$.
- Not covered by final test program.
- Switching duty cycle $D = 30\%$, $f_s = 23.0\text{ kHz}$.

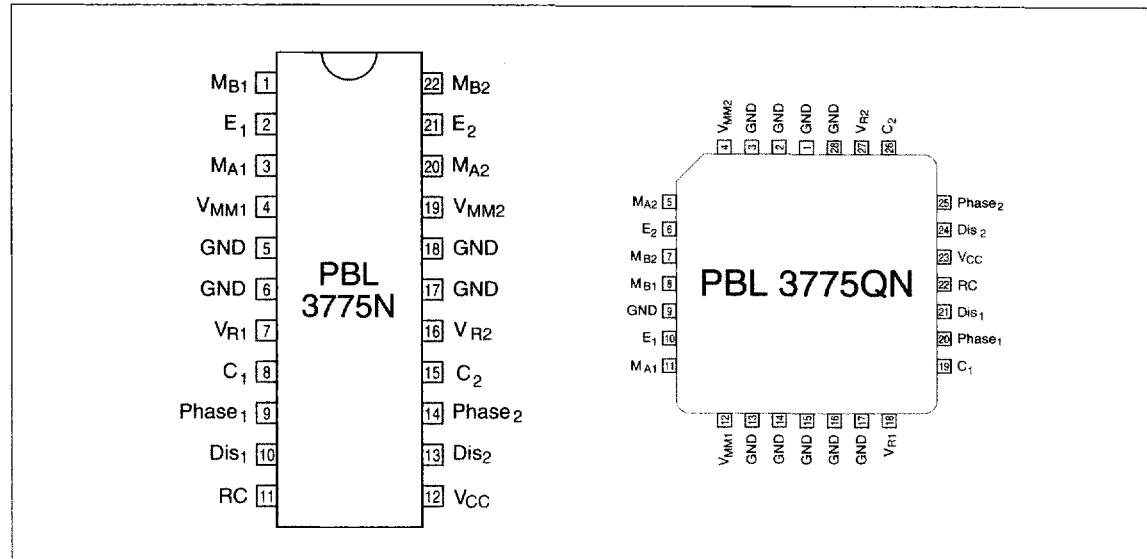

Figure 4. Pin configuration.

Pin Description

DIP	PLCC	Symbol	Description
1	[8]	M_{B1}	Motor output B, channel 1. Motor current flows from M_{A1} to M_{B1} when Phase ₁ is HIGH.
2	[10]	E_1	Common emitter, channel 1. This pin connects to a sensing resistor R_s to ground.
3	[11]	M_{A1}	Motor output A, channel 1. Motor current flows from M_{A1} to M_{B1} when Phase ₁ is HIGH.
4	[12]	V_{MM1}	Motor supply voltage, channel 1, +10 to +40 V. V_{MM1} and V_{MM2} should be connected together.
5, 6, 17, 18	[1-3, 9, 13-17, 28]	GND	Ground and negative supply. Note: these pins are used thermally for heat-sinking. Make sure that all ground pins are soldered onto a suitably large copper ground plane for efficient heat sinking.
7	[18]	V_{R1}	Reference voltage, channel 1. Controls the comparator threshold voltage and hence the output current.
8	[19]	C_1	Comparator input channel 1. This input senses the instantaneous voltage across the sensing resistor, filtered by the internal digital filter or an optional external RC network.
9	[20]	Phase ₁	Controls the direction of motor current at outputs M_{A1} and M_{B1} . Motor current flows from M_{A1} to M_{B1} when Phase ₁ is HIGH.
10	[21]	Dis ₁	Disable input for channel 1. When HIGH, all four output transistors are turned off, which results in a rapidly decreasing output current to zero.
11	[22]	RC	Clock oscillator RC pin. Connect a 12 kohm resistor to V_{CC} and a 4 700 pF capacitor to ground to obtain the nominal switching frequency of 23.0 kHz and a digital filter blanking time of 1.0 μ s.
12	[23]	V_{CC}	Logic voltage supply, nominally +5 V.
13	[24]	Dis ₂	Disable input for channel 2. When HIGH, all four output transistors are turned off, which results in a rapidly decreasing output current to zero.
14	[25]	Phase ₂	Controls the direction of motor current at outputs M_{A2} and M_{B2} . Motor current flows from M_{A2} to M_{B2} when Phase ₂ is HIGH.
15	[26]	C_2	Comparator input channel 2. This input senses the instantaneous voltage across the sensing resistor, filtered by the internal digital filter or an optional external RC network.
16	[27]	V_{R2}	Reference voltage, channel 2. Controls the comparator threshold voltage and hence the output current.
19	[4]	V_{MM2}	Motor supply voltage, channel 2, +10 to +40 V. V_{MM1} and V_{MM2} should be connected together.
20	[5]	M_{A2}	Motor output A, channel 2. Motor current flows from M_{A2} to M_{B2} when Phase ₂ is HIGH.
21	[6]	E_2	Common emitter, channel 2. This pin connects to a sensing resistor R_s to ground.
22	[7]	M_{B2}	Motor output B, channel 2. Motor current flows from M_{A2} to M_{B2} when Phase ₂ is HIGH.

Functional Description

Each channel of the PBL 3775 consists of the following sections: an output H-bridge with four transistors and four recirculation diodes, capable of driving up to 750 mA continuous current to the motor winding, a logic section that controls the output transistors, an S-R flip-flop, and a comparator. The clock-oscillator is common to both channels.

Constant current control is achieved by switching the output current to the windings. This is done by sensing the peak current through the winding via a current-sensing resistor R_s , effectively connected in series with the motor winding. As the current increases, a voltage develops across the sensing resistor, which is fed back to the comparator. At the predetermined level, defined by the voltage at the reference input V_{R1} , the comparator resets the flip-flop, which turns off the upper output transistor. The turn-off of one channel is independent of the other channel. The current decreases until the clock oscillator triggers the flip-flops of both channels simultaneously,

which turns on the output transistors again, and the cycle is repeated.

To prevent erroneous switching due to switching transients at turn-on, the PBL 3775 includes a digital filter. The clock oscillator provides a blanking pulse which is used for digital filtering of the voltage transient across the current sensing resistor during turn-on.

The current paths during turn-on, turn-off and phase shift are shown in figure 5.

Applications Information

Current control

The regulated output current level to the motor winding is determined by the voltage at the reference input and the value of the sensing resistor, R_s . The peak current through the sensing resistor (and the motor winding) can be expressed as:

$$I_{M,peak} = 0.1 \cdot V_R / R_s \quad [A]$$

With a recommended value of 0.5 ohm for the sensing resistor R_s , a 2.5 V reference voltage will produce an output current of approximately 0.5 A. R_s should be

selected for maximum motor current. Be sure not to exceed the absolute maximum output current which is 850 mA. Chopping frequency, winding inductance and supply voltage also affect the current, but to much less extent.

For accurate current regulation, the sensing resistor should be a 0.5 - 1.0 W precision resistor, i. e. less than 1% tolerance and low temperature coefficient.

Current sense filtering

At turn-on a current spike occurs, due to the recovery of the recirculation diodes and the capacitance of the motor winding. To prevent this spike from resetting the flip-flops through the current sensing comparators, the clock oscillator generates a blanking pulse at turn-on. The blanking pulse disables the comparators for a short time. Thereby any voltage transient across the sensing resistor will be ignored during the blanking time.

Choose the blanking pulse time to be longer than the duration of the switching transients by selecting a proper C_1 value.

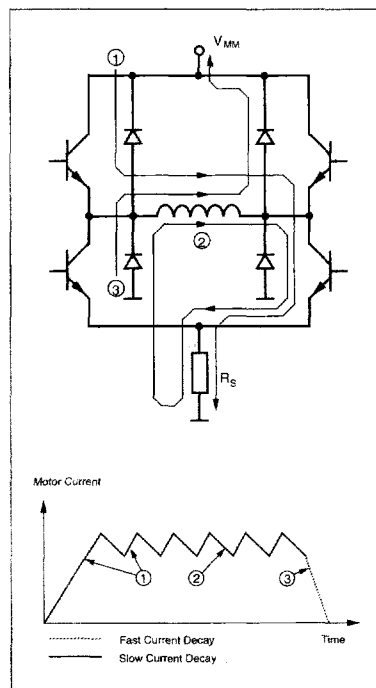

Figure 5. Output stage with current paths during turn-on, turn-off and phase shift.

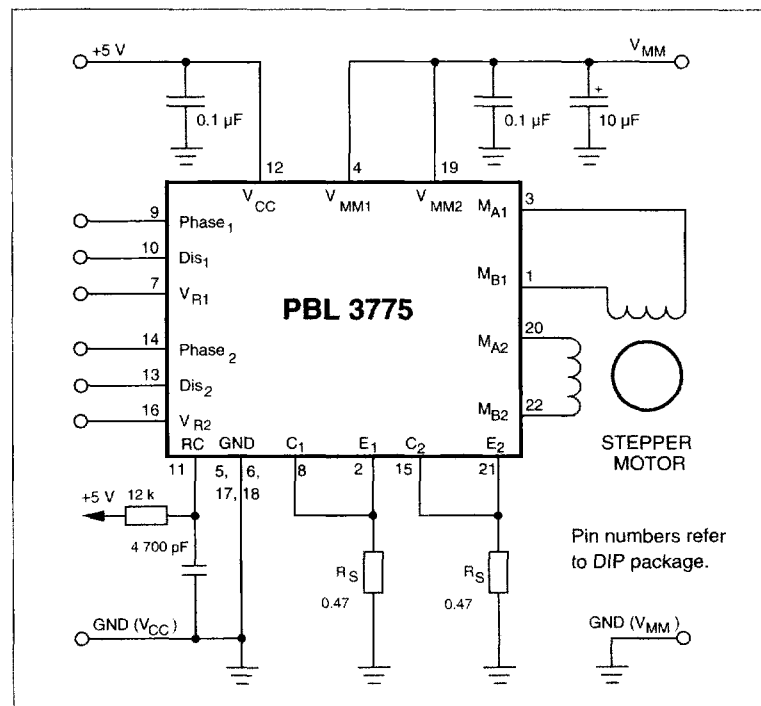

Figure 6. Typical stepper motor driver application with PBL 3775.

The time is calculated as:

$$t_b = 210 \cdot C_T \text{ [s]}$$

As the C_T value may vary from approximately 2 200 pF to 33 000 pF, a blanking time ranging from 0.5 μ s to 7 μ s is possible. Nominal value is 4 700 pF, which gives a blanking time of 1.0 μ s.

As the filtering action introduces a small delay, the peak value across the sensing resistor, and hence the peak motor current, will reach a slightly higher level than what is defined by the reference voltage. The filtering delay also limits the minimum possible output current. As the output will be on for a short time each cycle, equal to the digital filtering blanking time plus additional internal delays, an amount of current will flow through the winding. Typically this current is 1-10 % of the maximum output current set by R_S .

When optimizing low current performance, the filtering may be done by adding an external low pass filter in series with the comparator C input. In this case the digital blanking time should be as short as possible. The recommended filter component values are 10 kohm and 820 pF. Lowering the switching frequency also helps reducing the minimum output current.

To create an absolute zero current, the Dis input should be HIGH.

Switching frequency

The frequency of the clock oscillator is set by the timing components R_T and C_T at the RC-pin. As C_T sets the digital filter blanking time, the clock oscillator frequency is adjusted by R_T . The value of R_T is limited to 2 - 20 kohm. The frequency is approximately calculated as:

$$f_s = 1 / (0.77 \cdot R_T \cdot C_T)$$

Nominal component values of 12 kohm and 4 700 pF results in a clock frequency of 23.0 kHz. A lower frequency will result in higher current ripple, but may improve low level linearity. A higher clock frequency reduces current ripple, but increases the switching losses in the IC and possibly the iron losses in the motor.

Phase inputs

A logic HIGH on a Phase input gives a current flowing from pin M_A into pin M_B . A logic LOW gives a current flow in the opposite direction. A time delay prevents cross conduction in the H-bridge when changing the Phase input.

Dis (Disable) inputs

A logic HIGH on the Dis inputs will turn off all four transistors of the output H-bridge, which results in a rapidly decreasing output current to zero.

V_R (Reference) inputs

The V_{ref} inputs of the PBL 3775 have a voltage divider with a ratio of 1 to 10 to reduce the external reference voltage to an adequate level. The divider consists of closely matched resistors. Nominal input reference voltage is 5 V.

Interference

Due to the switching operation of PBL 3775, noise and transients are generated and might be coupled into adjacent circuitry. To reduce potential interference there are a few basic rules to follow:

- Use separate ground leads for power ground (the ground connection of R_S), the ground leads of PBL 3775, and the ground of external analog and digital circuitry. The grounds should be connected together close to the GND pins of PBL 3775.
- Decouple the supply voltages close to the PBL 3775 circuit. Use a ceramic capacitor in parallel with an electrolytic type for both V_{CC} and V_{MM} . Route the power supply lines close together.
- Do not place sensitive circuits close to the driver. Avoid physical current loops, and place the driver close to both the motor and the power supply connector. The motor leads could preferably be twisted or shielded.

Motor selection

The PBL 3775 is designed for two-phase bipolar stepper motors, i.e. motors that have only one winding per phase.

The chopping principle of the PBL 3775 is based on a constant frequency and a varying duty cycle. This scheme imposes certain restrictions on motor selection. Unstable chopping can occur if the chopping duty cycle exceeds approximately 50 %. See figure 3 for definitions. To avoid this, it is necessary to choose a motor with a low winding resistance and inductance, i.e. windings with a few turns.

It is not possible to use a motor that is rated for the same voltage as the actual supply voltage. Only rated current needs to be considered. Typical motors to be used together with the PBL 3775 have a voltage rating of 1 to 6 V, while the supply voltage usually ranges from 12 to 40 V.

Low inductance, especially in combination with a high supply voltage, enables high stepping rates. However, to give the same torque capability at low speed, the reduced number of turns in the winding in

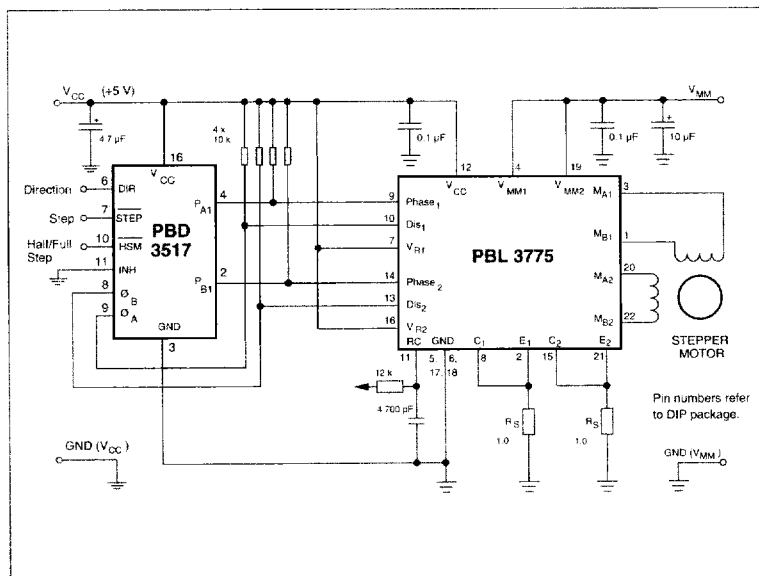

Figure 7. Half stepping system where PBD 3517 is used as controller circuit in order to generate the necessary sequence to the PBL 3775.

the low resistive, low inductive motor must be compensated by a higher current. A compromise has to be made. Choose a motor with the lowest possible winding resistance and inductance, that still gives the required torque, and use as high supply voltage as possible, without exceeding the maximum recommended 40 V. Check that the chopping duty cycle does not exceed 50 % at maximum current.

Heat sinking

PBL 3775 is a power IC, packaged in a power DIP or PLCC package. The ground leads of the package (the batwing) are thermally connected to the chip. External heatsinking is achieved by soldering the ground leads onto a copper ground plane on the PCB.

Maximum continuous output current is heavily dependent on the heatsinking and ambient temperature. Consult figures 8, 9 and 14 to determine the necessary heat-sink, or to find the maximum output current under varying conditions.

A copper area of 20 cm² (approx. 1.8" x 1.8"), copper foil thickness 35 μm on a 1.6 mm epoxy PCB, permits the circuit to operate at 2 x 450 mA output current, at ambient temperatures up to 85° C.

Thermal shutdown

The circuit is equipped with a thermal shutdown function that turns the outputs off at a chip (junction) temperature above 160° C. Normal operation is resumed when the temperature has decreased about 20° C.

Programming

Figure 15 shows the different input and output sequences for full-step, half-step and modified halfstep operations. **Full-step mode.** Both windings are energized at all the time with the same current, $I_{M1} = I_{M2}$. To make the motor take one step, the current direction (and the magnetic field direction) in one phase is reversed. The next step is then taken when the other phase current reverses. The current changes go through a sequence of four different states which equal four full steps until the initial state is reached again.

Half-step mode. In the half-step mode, the current in one winding is brought to zero before a complete current reversal is made. The motor will then have taken two half steps equalling one full step in rotary movement. The cycle is repeated, but on

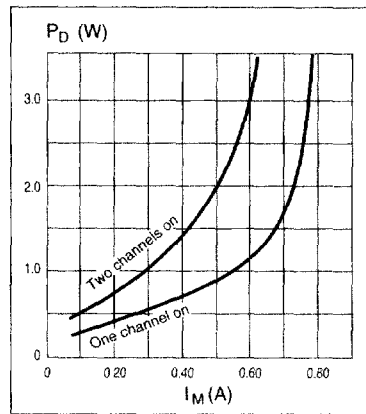

Figure 8. Power dissipation vs. motor current. $T_a = 25^{\circ}\text{C}$.

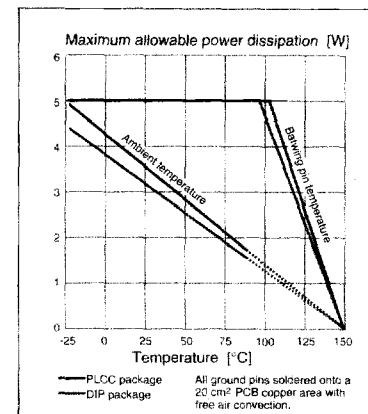

Figure 9. Maximum allowable power dissipation.

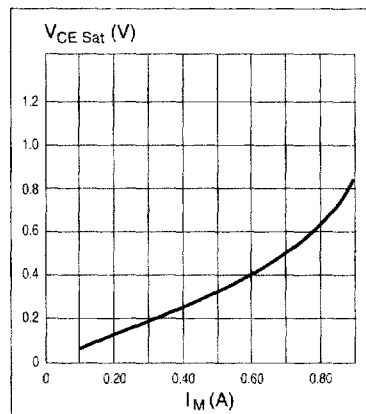

Figure 10. Typical lower transistor saturation voltage vs. output current.

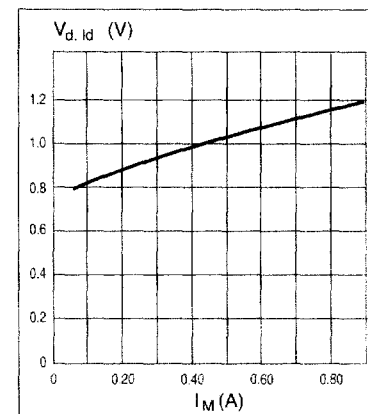

Figure 11. Typical lower diode voltage drop vs. recirculating current.

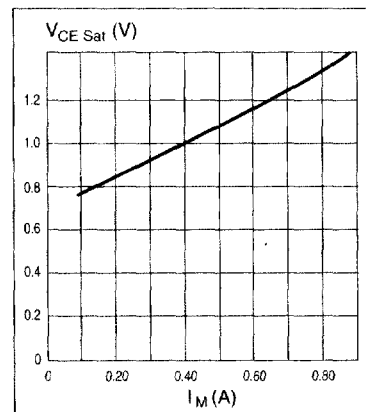

Figure 12. Typical upper transistor saturation voltage vs. output current.

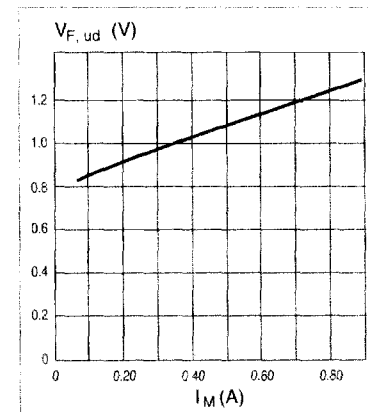

Figure 13. Typical upper diode voltage drop vs. recirculating current.

the other phase. A total of eight states are sequenced until the initial state is reached again.

Half-step mode can overcome potential resonance problems. Resonances appear as a sudden loss of torque at one or more distinct stepping rates and must be avoided so as not to lose control of the motor's shaft position.

One disadvantage with the half-step mode is the reduced torque in the half step positions, in which current flows through one winding only. The torque in this position is approximately 70 % of the full step position torque.

Modified half-step mode. The torque variations in half step mode will be eliminated if the current is increased about 1.4 times in the halfstep position. A constant torque will further reduce resonances and mechanical noise, resulting in better performance, life expectancy and reliability of the mechanical system.

Modifying the current levels must be done by bringing the reference voltage up (or down) from its nominal value correspondingly. This can be done by using DACs or simple resistor divider networks. The PBL 3775 is designed to handle about 1.4 times higher current in one channel on mode, for example 2 x 500 mA in the full-step position, and 1 x 700 mA in the half-step position.

Ordering Information

Package	Temp. range	Part No.
Plastic DIP	-40 to +85° C	PBL 3775N
PLCC	-40 to +85° C	PBL 3775QN

Information given in this data sheet is believed to be accurate and reliable. However no responsibility is assumed for the consequences of its use nor for any infringement of patents or other rights of third parties which may result from its use. No license is granted by implication or otherwise under any patent or patent rights of Ericsson Components. These products are sold only according to Ericsson Components' general conditions of sale, unless otherwise confirmed in writing.

Specifications subject to change without notice.

IC4(91005) C-Ue

© Ericsson Components AB 1995

ERICSSON 

Ericsson Components AB
S-164 81 Kista-Stockholm, Sweden
Telephone: (08) 757 50 00

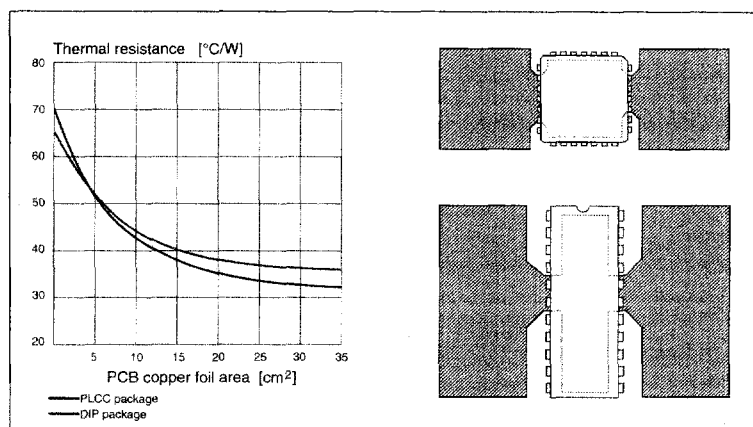

Figure 14. Typical thermal resistance vs. PC Board copper area and suggested layout.

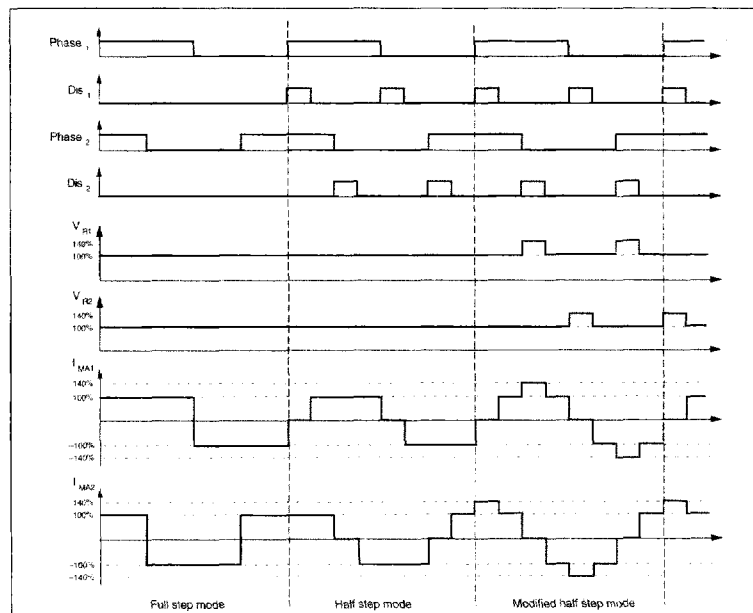

Figure 15. Stepping modes.