

CMOS SYNCHRONOUS 4-BIT COUNTERS

FEATURES

- ◆ BCD Decade (4160B, 4162B) or 4-Bit Binary (4161B, 4163B) Counting
- ◆ Internal Look-Ahead for Fast Counting
- ◆ Carry Output for Cascading
- ◆ Synchronously Programmable
- ◆ Synchronous Counting
- ◆ Load Control Input
- ◆ Clear Input - Asynchronous (4160B, 4161B) or Synchronous (4162B, 4163B)
- ◆ Static Operation - DC to 5MHz @ 10Vdc

DESCRIPTION

The 4160B - 4163B are Synchronous Programmable Counters constructed with complementary MOS P-Channel and N-Channel enhancement-mode devices in a single monolithic structure. These counters are functionally equivalent to the 74160 - 74163 TTL counters.

Two are synchronous programmable decade counters with asynchronous and synchronous Clear inputs respectively (4160, 4162). The other two are 4-bit binary counters with asynchronous and synchronous Clear respectively (4161, 4163).

SYNCHRONOUS MODE SELECTION 4160B/4161B

L	PE	TE	Mode
L	X	X	Preset
H	L	X	No Change
H	X	L	No Change
H	H	H	Count

H = High level L = Low level X = Don't care

SYNCHRONOUS MODE SELECTION 4162B/4163B

CLR	L	PE	TE	Mode
H	L	X	X	Preset
H	H	L	X	No Change
H	H	X	L	No Change
H	H	H	H	Count
L	X	X	X	Reset

H = High level L = Low level X = Don't care

CONNECTION DIAGRAM (all packages)

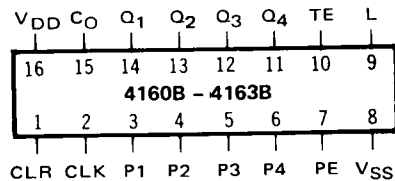

Add suffix for package:

- C 16-pin Cerdip
- D 16-pin Ceramic
- E 16-pin Epoxy
- F 16-pin Flat
- H Chip

RECOMMENDED OPERATING CONDITIONS

For maximum reliability:

DC Supply Voltage	$V_{DD} - V_{SS}$	3 to 15	Vdc
Operating Temperature	T_A	-55 to +125	°C
C, D, F, H Device		-40 to +85	°C
E Device			

BLOCK DIAGRAM

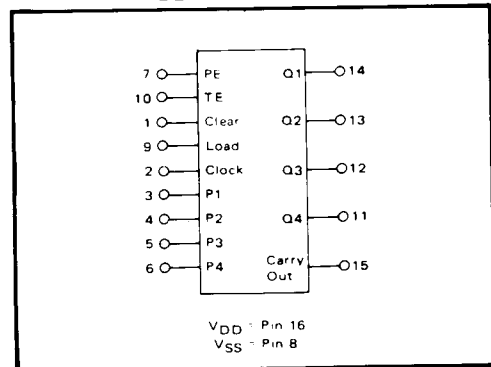

SELECTOR GUIDE

CLEAR	MODULUS	
	DECADE	BINARY
Asynchronous	4160B	4161B
Synchronous	4162B	4163B

FUNCTIONAL DESCRIPTION

These counters are fully programmable; that is, the outputs may be preset to either level. As pre-setting is synchronous, setting up a low level at the Load input disables the counter and causes the outputs to agree with the setup data after the next Clock pulse regardless of the levels of the Enable inputs. Low-to-high transitions at the Load input should be avoided when the Clock is low if the Enable inputs are high at or before the transition. The Clear function for the 4160, 4161 is asynchronous and a low level at the Clear input sets all four of the flip-flop outputs low regardless of the levels of the Clock, Load or Enable inputs. The Clear function for the 4162 and 4163 is synchronous and a low level at the Clear inputs sets all four of the flip-flop outputs low after the next Clock pulse regardless of the levels of the Enable inputs. This synchronous Clear allows the count length to be modified easily; decoding the

maximum count desired can be accomplished with one external NAND gate. The gate output is connected to the Clear input to synchronously clear the counter to 0000 (LLLL).

The carry look-ahead circuitry provides for cascading counters for n-bit synchronous applications without additional gating. Instrumental in accomplishing this function are two Count Enable inputs and a Carry output. Both Count Enable inputs (PE, TE) must be high to count, and Enable input TE is fed forward to enable the carry output. The Carry output thus enabled will produce a positive output pulse with a duration approximately equal to the positive portion of the Q1 output. This positive overflow Carry pulse can be used to enable successive cascaded stages. High-to-low-level transitions at the Enable PE or TE inputs should occur only when the Clock input is high.

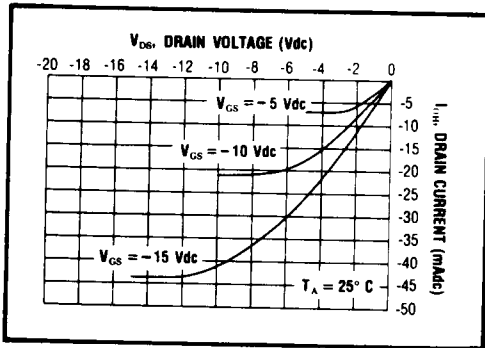

Typical P-Channel Source Current Characteristics

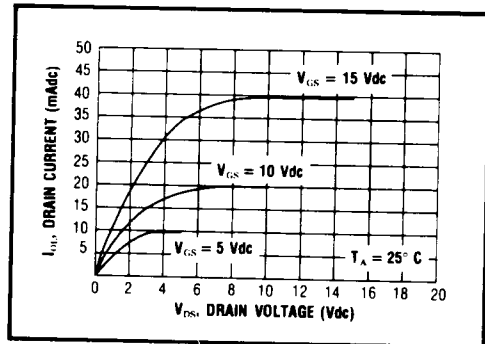

Typical N-Channel Sink Current Characteristics

SWITCHING WAVEFORMS

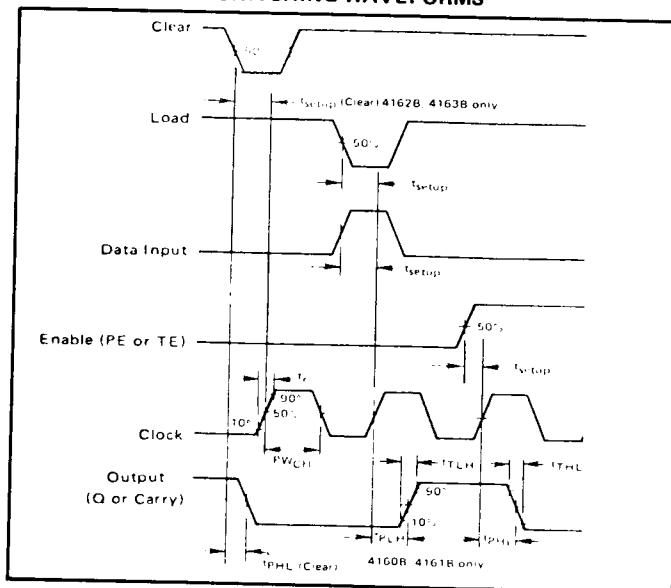

ELECTRICAL CHARACTERISTICS

STATIC CHARACTERISTICS¹

PARAMETER	V _{DD} (Vdc)	CONDITIONS	T _{LOW} ²		+25°C			T _{HIGH} ²		Units
			Min.	Max.	Min.	Typ.	Max.	Min.	Max.	
QUIESCENT DEVICE CURRENT	I _{DD}	V _{IN} = V _{SS} or V _{DD} All valid input combinations	—	5	—	0.05	5	—	150	μAdc
			—	10	—	0.1	10	—	300	
			—	20	—	0.2	20	—	600	

NOTES: ¹ Remaining Static Electrical Characteristics are listed under "4000B Series Family Specifications".

² T_{LOW} = -55°C for C, D, F, H device.

= -40°C for E device.

T_{HIGH} = +125°C for C, D, F, H device.

= + 85°C for E device.

DYNAMIC CHARACTERISTICS (C_L = 50pF, T_A = 25°C)

PARAMETER	V _{DD} (Vdc)	Min.	Typ.	Max.	Units					
CLOCKED OPERATION										
PROPAGATION DELAY TIME Clock to Q	t _{PLH} , t _{PHL}	5	—	200	ns					
		10	—	80						
		15	—	60						
Clock to Carry Out		5	—	240	ns					
		10	—	95						
		15	—	75						
TE to Carry Out		5	—	180	ns					
		10	—	70						
		15	—	50						
OUTPUT TRANSITION TIME	t _{TLH} , t _{THL}	5	—	100	200	ns				
		10	—	50	100					
		15	—	40	80					
MINIMUM CLOCK PULSE WIDTH	PW _{CL}	5	—	85	170	ns				
		10	—	35	70					
		15	—	25	50					
MAXIMUM CLOCK FREQUENCY	f _{CL}	5	2.0	3.0	—	MHz				
		10	5.5	8.5	—					
		15	8.0	12.0	—					
MAXIMUM CLOCK RISE AND FALL TIME ¹	t _{rCL} , t _{fCL}	5	50	∞	—	ms				
		10	50	∞	—					
		15	50	∞	—					
MINIMUM SETUP TIME	t _{setup}	5	—	120	240	ns				
Data to Clock										
Load to Clock		5	—	120	240	ns				
							10	—	45	90
							15	—	30	65
PE or TE to Clock		5	—	170	340	ns				
							10	—	70	140
							15	—	50	100
CLEAR OPERATION										
PROPAGATION DELAY TIME	t _{PLH} , t _{PHL}	5	—	150	300	ns				
Clear to Q										
(4160, 4161 only)										
		10	—	50	100					
		15	—	30	60					
MINIMUM SETUP TIME	t _{setup}	5	—	120	240	ns				
Clear to Clock										
(4162, 4163 only)										
		10	—	50	100					
		15	—	30	60					

¹ When units are cascaded, the maximum rise and fall times of the clock input should be equal to or less than the transition times of the data outputs driving data inputs, plus the propagation delay of the output driving stage for the output capacitive load.

4160B, 4162B LOGIC DIAGRAM
(Clear is synchronous for 4162B)

Sequence illustrated in waveforms:

1. Clear outputs to zero.
2. Preset to BCD seven.
3. Count to eight, nine, zero, one, two and three.
4. Inhibit

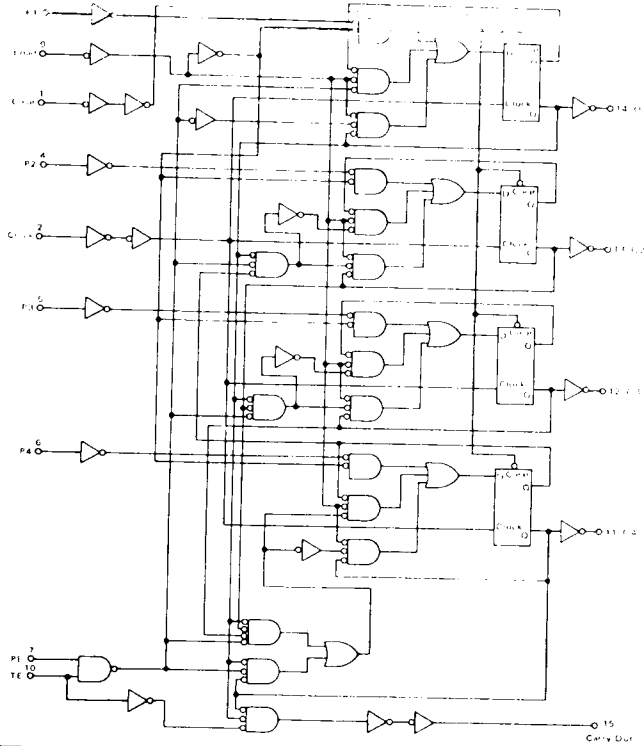

4160B, 4162B TIMING DIAGRAM

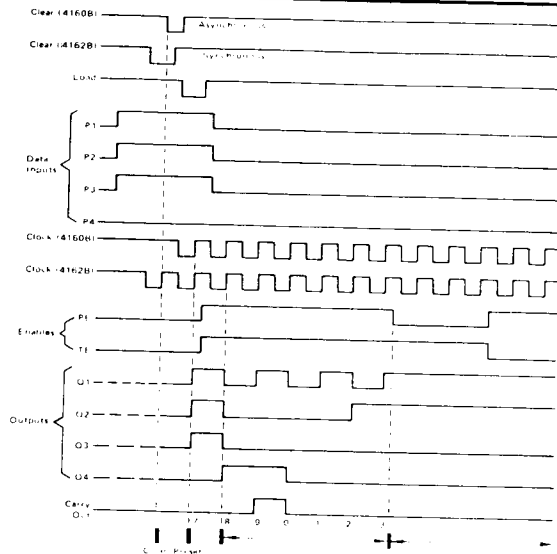

4161B, 4163B LOGIC DIAGRAM
(Clear is Synchronous for 4163B)

Sequence illustrated in waveforms:

1. Clear outputs to zero.
2. Preset to binary twelve.
3. Count to thirteen, fourteen, fifteen, zero, one and two.
4. Inhibit.

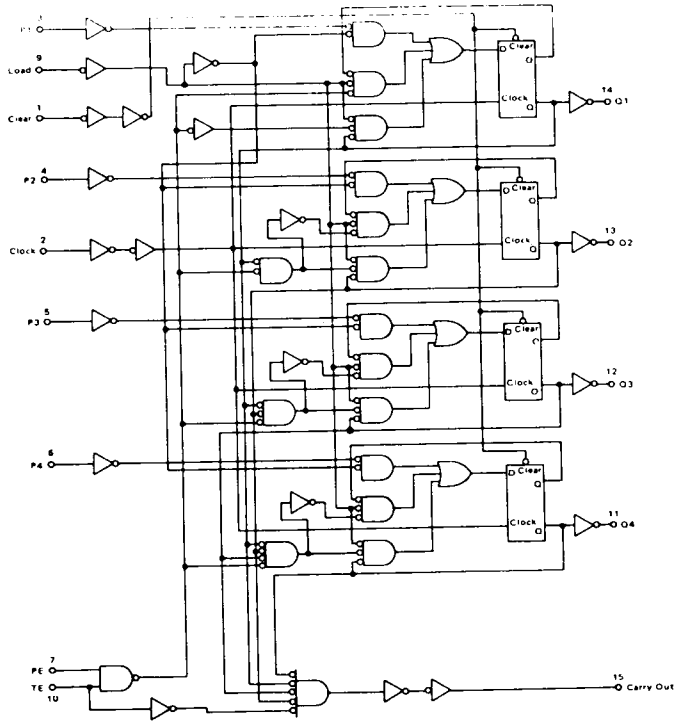

4161B, 4163B TIMING DIAGRAM

